

PAD	CONNECTION
1	Enable / disable
2	Ground
3	Output
4	Supply

TP = Test Point

Features

- ▶ High stability for WiMax, LAN etc
- ▶ Low current consumption
- ▶ Enable / disable tristate function
- ▶ Miniature ceramic package with metal lid
- ▶ Competitive pricing

Enable / Disable Function

Input (pad 1)	Output (pad 3)
Open	Enabled
'1' level	Enabled
'0' level	High Impedance

Specifications

GXO-5332J: 2.5V supply

GXO-5332N: 3.0V supply

GXO-5332L: 3.3V supply

Parameters	Variant			Option Codes	
	J	N	L		
Frequency range:	4.0 ~ 54.0MHz	■	■	■	
Frequency stability*:	±15ppm ±10ppm	■ □	■ □	■ □	E F
Operating temperature range:	-40 to +85°C	■	■	■	
Storage temperature range:	-40 to +85°C	■	■	■	
Supply voltage (V _{DD}):	+2.5V (±10%) +3.0V (±10%) +3.3V (±10%)	■	■	■	
Supply current:	7mA max (3.1mA typ @ 40MHz, 2.5V)	■	■	■	
Logic levels:	'0' level = 10%V _{DD} max '1' level = 90%V _{DD} min	■	■	■	
Start up time:	0.2ms typ	■	■	■	
Waveform symmetry:	45:55 max @ 50%V _{DD}	■	■	■	
Driving ability:	15pF HCMOS	■	■	■	
Rise / fall time:	5ns max	■	■	■	
Enable / disable function:	Tristate (control via pad 1) (E/D times 100µs / 100µs typ)	■	■	■	
Stand-by current:	10µA max	■	■	■	
Period jitter RMS:	3ps typ	■	■	■	
Phase jitter RMS:	0.09ps typ, 12kHz~10MHz	■	■	■	
Phase noise:	-143dBc/Hz typ @ 10kHz	■	■	■	

■ Standard. □ Optional - Please specify required code(s) when ordering

* Frequency stability is inclusive of calibration @ 25°C, operating temperature range, supply voltage change, load change, reflow and ageing.

Ordering Information

Product name + variant + option code + frequency

eg: **GXO-5332L/E 40.0MHz** 3.3V, ±15ppm

GXO-5332J/F 32.0MHz 2.5V, ±10ppm

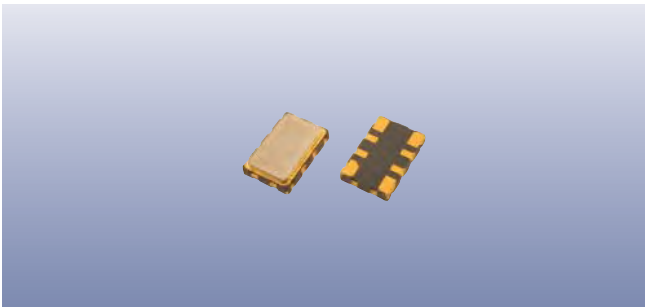

Construction

- ▮ Ceramic body with gold-plated pads
- ▮ Metal lid, seam sealed

Composition



This product is lead-free, and is fully compliant with the RoHS 2 directive 2011/65/EU



Packaging & Handling

Production quantities supplied on T&R, 1k pcs per reel.
Small quantities may be supplied on tape (no reel), or in bulk.



♦ Static sensitive product. Observe proper handling precautions

Marking

FREQUENCY
DC

Marking type: Laser
DC = Date code in YM, eg "CE" = May 2003

	A	B	C	D	E	F	G	H	J	K	L	M
Y	1	2	3	4	5	6	7	8	9	0		
M	Jan	Feb	Mar	Apr	May	Jun	Jul	Aug	Sep	Oct	Nov	Dec

Tape & Reel Specification

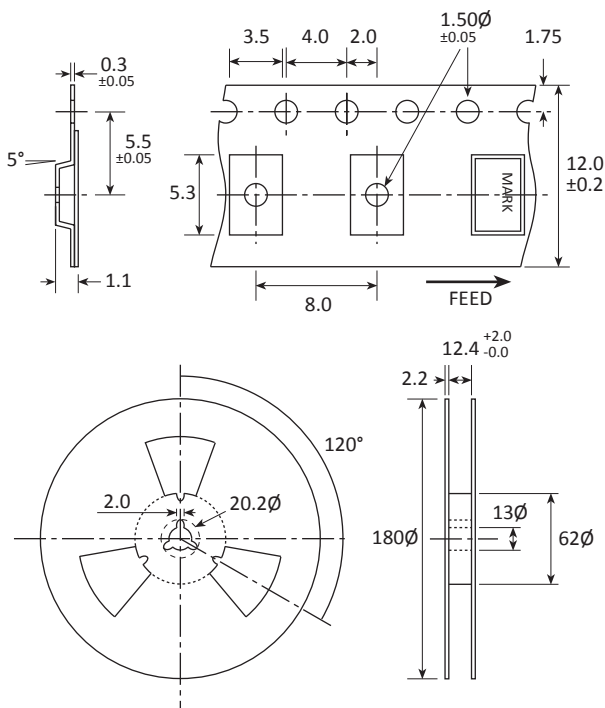

Not to scale. Dimensions in mm. Tolerances ±0.1mm unless otherwise stated.

Soldering Profile

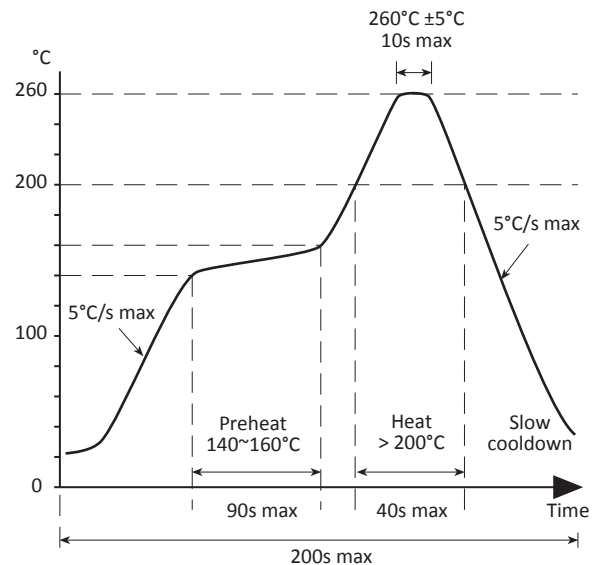

Solder resistance: 260°C x 10 secs x 2.