

Customer Information Sheet

DRAWING No.: H2157-XX

SHEET 2 OF 2

IF IN DOUBT - ASK

©

NOT TO SCALE

THIRD ANGLE PROJECTION

ALL DIMENSIONS IN mm

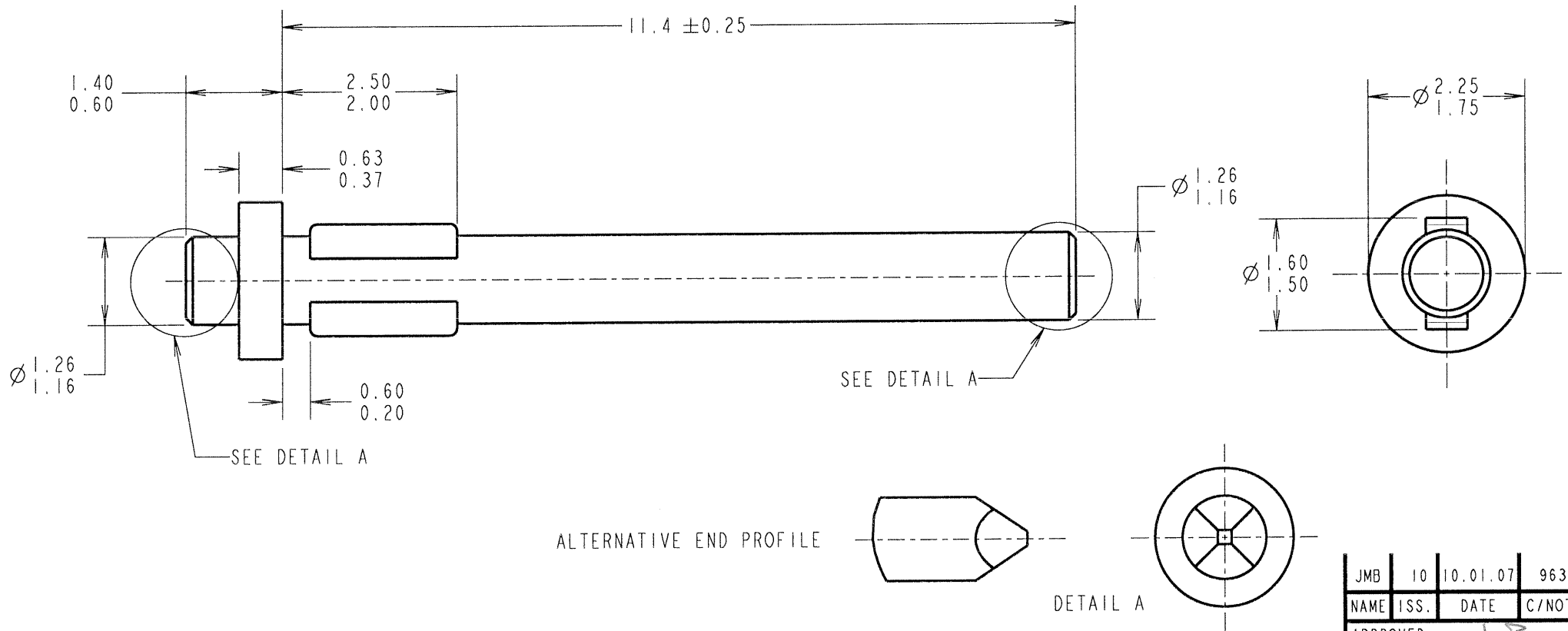

- NOTES:
1. RECOMMENDED MOUNTING HOLE SIZE = \varnothing 1.40-1.50mm.
 2. RECOMMENDED PANEL THICKNESS = 1.6/2.4mm.
 3. PUNCH & DIE TOOL PART No. = Z2157-00.

PART No.	FINISH
H2157-00	UNPLATED
H2157-01	7.6 μ 100% TIN

JMB	10	10.01.07	9638
NAME	ISS.	DATE	C/NOTE
APPROVED: <i>JLB</i>			
CHECKED: <i>[Signature]</i>			
DRAWN: S. D. C			
CUSTOMER REF.:			
ASSEMBLY DRG:			

HARWIN

HARWIN INC U.S.A.	HARWIN PLC U.K.	HARWIN PTE SINGAPORE
TEL: (812) 542 2540 FAX: (812) 542 2541	TEL: 023 9231 4545 FAX: 023 9231 4590	TEL: 65 6779 4909 FAX: 65 6779 3868

THIS DRAWING AND ANY INFORMATION OR DESCRIPTIVE MATTER SET OUT HEREON ARE CONFIDENTIAL AND COPYRIGHT PROPERTY OF THE HARWIN GROUP AND MUST NOT BE DISCLOSED, LOANED, COPIED OR USED FOR MANUFACTURING, TENDERING OR FOR ANY OTHER PURPOSE WITHOUT THEIR WRITTEN PERMISSION.

TOLERANCES

X. = \pm 1mm
 X.X = \pm 0.25mm
 X.XX = \pm 0.10mm
 X.XXX = \pm 0.01mm

ANGLES = \pm 5°

UNLESS STATED

MATERIAL:
BRASS CW614N TO BS EN 12164
(CuZn39Pb3)

FINISH: SEE TABLE

S/AREA: mm²

TITLE:
TERMINAL PIN

DRAWING NUMBER:
H2157-XX

SHT
2
OF
2