

# Customer Information Sheet

DRAWING No.: H3185-XX

SHEET 2 OF 2

IF IN DOUBT - ASK

©

NOT TO SCALE

THIRD ANGLE PROJECTION

ALL DIMENSIONS IN mm

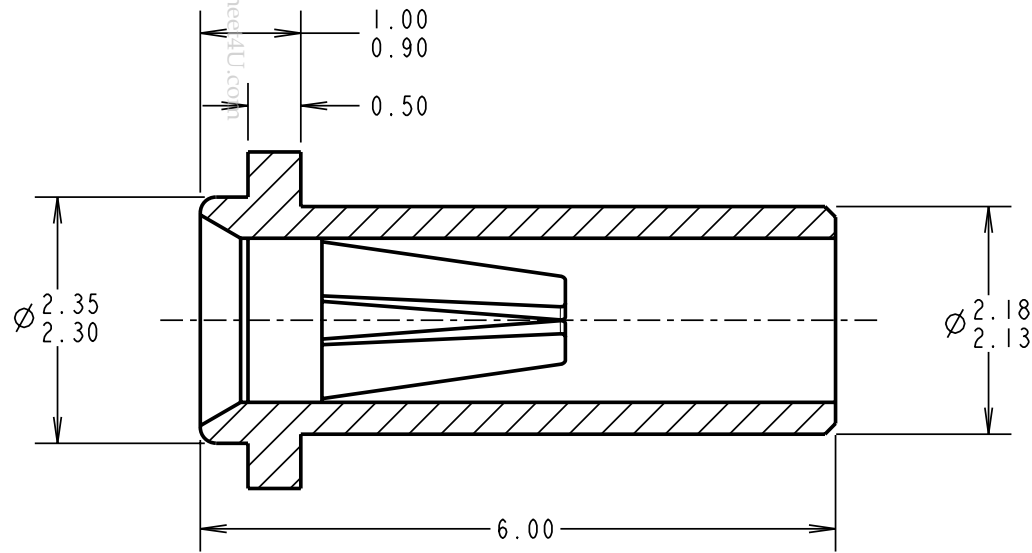

SECTION A-A

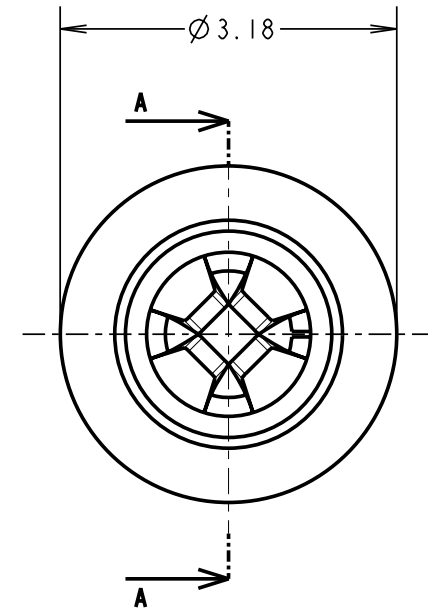

**SPECIFICATION:**

**MATERIAL:**  
 CONTACT SHELL = BRASS  
 CONTACT CLIP = BERYLLIUM COPPER  
**FINISH:**  
 01 = 4µm TIN SHELL, 0.15µm GOLD CLIP  
 05 = 0.1µm GOLD SHELL, 0.15µm GOLD CLIP  
 46 = 4µm 100% TIN SHELL, 3µm 100% TIN CLIP

**ELECTRICAL:**  
 CURRENT RATING AT 25°C = 10A MAX  
 CURRENT RATING AT 85°C = 7.5A MAX  
 CONTACT RESISTANCE = 25 MILLIOHMS MAX

**MECHANICAL:**  
 INSERTION FORCE (∅1mm GAUGE) = 9N MAX, 3N MIN  
 WITHDRAWAL FORCE (∅1mm GAUGE) = 3N MAX, IN MIN

**DURABILITY:**  
 01, 05 = 1000 OPERATIONS  
 46 = 100 OPERATIONS

**ENVIRONMENTAL:**  
 OPERATING TEMPERATURE = -55°C TO +125°C

**NOTES:**

- FOR COMPLETE SPECIFICATION, SEE COMPONENT SPECIFICATION C009XX (LATEST ISSUE).
- MAXIMUM CONTACT DEPTH = 3.55mm.
- RECOMMENDED MOUNTING HOLE SIZE = ∅2.29-2.19mm.
- RECOMMENDED PIN SIZE = ∅1.05-0.90mm.

ORDER CODE:

**H3185-XX**

FINISH:

- 01 = TIN SHELL, GOLD CLIP
- 05 = GOLD SHELL, GOLD CLIP
- 46 = 100% TIN SHELL & TIN CLIP

RA	10	11.02.09	10286
NAME	ISS.	DATE	C/NOTE
APPROVED:		R.ADDE	
CHECKED:			
DRAWN:		I. SANDY	
CUSTOMER REF.:			
ASSEMBLY DRG:			

**HARWIN**

HARWIN USA TEL: 603 893 5376 FAX: 603 893 5396 mis@harwin.com  
 HARWIN Europe (UK) TEL: 023 9231 4545 FAX: 023 9231 4590 mis@harwin.co.uk  
 HARWIN Asia TEL: +65 6 779 4909 FAX: +65 6 779 3868 mis@harwin.com.sg

THIS DRAWING AND ANY INFORMATION OR DESCRIPTIVE MATTER SET OUT HEREON ARE CONFIDENTIAL AND COPYRIGHT PROPERTY OF THE HARWIN GROUP AND MUST NOT BE DISCLOSED, LOANED, COPIED OR USED FOR MANUFACTURING, TENDERING OR FOR ANY OTHER PURPOSE WITHOUT THEIR WRITTEN PERMISSION.

**TOLERANCES**  
 X. = ±1mm  
 X.X = ±0.25mm  
 X.XX = ±0.10mm  
 X.XXX = ±0.01mm  
 ANGLES = ±5°  
 UNLESS STATED

**MATERIAL:** SEE ABOVE  
**FINISH:** SEE ABOVE  
**S/AREA:** mm<sup>2</sup>

**TITLE:** ∅1.00mm SOCKET ASSEMBLY  
**DRAWING NUMBER:** H3185-XX  
 SHT 2 OF 2