

Customer Information Sheet

DRAWING No.: H3492-XX

SHEET 2 OF 2

IF IN DOUBT - ASK

©

NOT TO SCALE

THIRD ANGLE PROJECTION

ALL DIMENSIONS IN mm

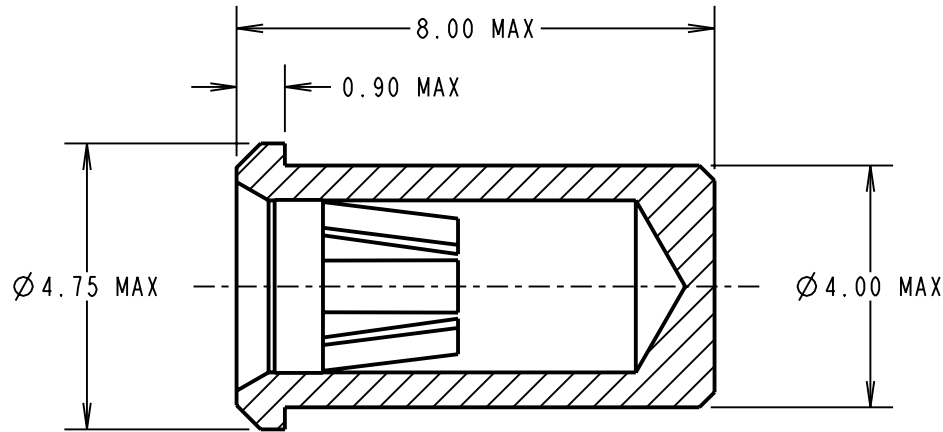

SECTION A-A

SPECIFICATION:

MATERIALS:

SHELL = BRASS CW614N TO BS EN 12164: 1998

CLIP = BERYLLIUM COPPER C17200 HM

FINISH:

01 = 0.10-0.15µ GOLD CLIP, 3.5-5.0µ 100% TIN SHELL

05 = 0.10-0.15µ GOLD CLIP, 0.05-0.10µ GOLD SHELL

46 = 2.4-3.6µ 100% TIN CLIP, 3.5-5.0µ 100% TIN SHELL

ELECTRICAL:

CURRENT RATING = 20A MAX

CONTACT RESISTANCE = 25 MILLIOHMS MAX

MECHANICAL:

DURABILITY = 01 - 500 CYCLES

05 - 500 CYCLES

46 - 50 CYCLES

INSERTION FORCE (Ø2.00mm GAUGE) = 6N MAX, 3N MIN

WITHDRAWAL FORCE (Ø2.00mm GAUGE) = 3N MAX, 1N MIN

MATING PIN SIZE = Ø2.3-2.0mm

CONTACT DEPTH = 4.1mm MAX

PIN LENGTH = 6.30mm MAX

ENVIRONMENTAL:

TEMPERATURE RANGE = -55°C TO +125°C

FOR COMPLETE MECHANICAL AND ELECTRICAL SPECIFICATION

SEE COMPONENT SPECIFICATION C031XX (LATEST ISSUE).

NOTES:

1. RECOMMENDED MOUNTING HOLE = Ø4.02-4.12mm

ORDER CODE:

H3492-XX

FINISH:

01 = GOLD CLIP, TIN SHELL

05 = GOLD CLIP, GOLD SHELL

46 = 100% TIN CLIP, TIN SHELL

CP	5	05.02.10	10669
NAME	ISS.	DATE	C/NOTE
APPROVED:		C.PENROSE	
CHECKED:		R.ADDE	
DRAWN:		A.LIOTTA	
CUSTOMER REF.:			
ASSEMBLY DRG:			

HARWIN

THIS DRAWING AND ANY INFORMATION OR DESCRIPTIVE MATTER SET OUT HEREON ARE CONFIDENTIAL AND COPYRIGHT PROPERTY OF THE HARWIN GROUP AND MUST NOT BE DISCLOSED, LOANED, COPIED OR USED FOR MANUFACTURING, TENDERING OR FOR ANY OTHER PURPOSE WITHOUT THEIR WRITTEN PERMISSION.

TOLERANCES

X. = ±1mm
 X.X = ±0.25mm
 X.XX = ±0.10mm
 X.XXX = ±0.01mm

ANGLES = ±5°
 UNLESS STATED

MATERIAL:

SEE ABOVE

FINISH: SEE ABOVE

S/AREA: mm²

TITLE:

Ø2.00mm SOCKET ASSEMBLY

DRAWING NUMBER:

H3492-XX

SHT
 2 OF 2

HARWIN USA
 TEL: 603 893 5376
 FAX: 603 893 5396
 mis@harwin.com

HARWIN Europe (UK)
 TEL: 023 9231 4545
 FAX: 023 9231 4590
 mis@harwin.co.uk

HARWIN Asia
 TEL: +65 6 779 4909
 FAX: +65 6 779 3868
 mis@harwin.com.sg