







500V N-Channel Planar MOSFET

<p>HRH5N50ADNx Description</p> <p>500V N-Channel Planar MOSFET</p> <p>HRH5N50ADNx is HRM high voltage MOSFET family based on advanced planar stripe DMOS technology. This advanced MOSFET family has optimized on-state resistance, and also provides superior switching performance and higher avalanche energy strength. This device family is suitable for high efficiency switch mode power supplies.</p>	<div style="display: flex; justify-content: space-around;"> <div style="text-align: center;"> <p>TO-252</p>  </div> <div style="text-align: center;"> <p>TO-220F</p>  </div> </div> <div style="display: flex; justify-content: space-around; margin-top: 20px;"> <div style="text-align: center;"> <p>TO-220</p>  </div> <div style="text-align: center;"> <p>TO-251</p>  </div> </div>	
<p>HRH5N50ADNx Features</p> <ul style="list-style-type: none"> ● $R_{DS(on)} \leq 1.5\Omega$ @ $V_{gs}=10V, I_d=2.5A$ ● Ultra Low gate Charge (typical 16.5nC) ● Low C_{rss} (typical 7.2pF) ● Fast switching capability ● 100% avalanche tested ● Improved dv/dt capability 	<div style="display: flex; align-items: center;"> <div style="flex: 1;">  </div> <div style="flex: 1; text-align: center;">  </div> </div>	
<p>HRH5N50ADNx Applications</p> <ul style="list-style-type: none"> ● Switch Mode Power Supply (SMPS) ● Uninterruptible Power Supply (UPS) ● Power Factor Correction (PFC) (PFC) ● Charger 		
<p>HRH5N50ADNx Key Performance Parameters</p>		
<p>Parameter</p>	<p>Value</p>	<p>Unit</p>
<p>$V_{DS} @ T_{J,max}$</p>	<p>550</p>	<p>V</p>
<p>$R_{DS(on),max}$</p>	<p>1.5</p>	<p>Ω</p>
<p>$Q_{g,typ}$</p>	<p>16.5</p>	<p>nC</p>
<p>I_D</p>	<p>5</p>	<p>A</p>
<p>$I_{D,pulse}$</p>	<p>20</p>	<p>A</p>
<p>HRH5N50ADNx Device Marking and Package Information</p>		
<p>Device</p>	<p>Package</p>	<p>Marking</p>
<p>HRH5N50ADND</p>	<p>TO-252</p>	<p>H5N50ADND</p>
<p>HRH5N50ADNF</p>	<p>TO-220F</p>	<p>H5N50ADNF</p>
<p>HRH5N50ADNP</p>	<p>TO-220</p>	<p>H5N50ADNP</p>
<p>HRH5N50ADNU</p>	<p>TO-251</p>	<p>H5N50ADNU</p>

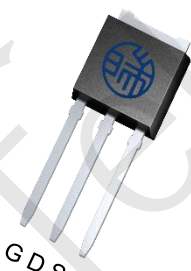
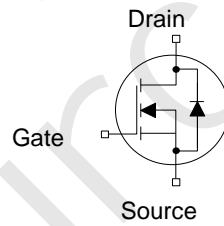

HRH5N50ADNx Absolute Maximum Ratings $T_C = 25^\circ\text{C}$, unless otherwise noted			
Parameter	Symbol	Value	Unit
Drain-Source Voltage($V_{GS}=0V$)	V_{DS}	500	V
Continuous Drain Current ¹⁾	I_D	$T_C = 25^\circ\text{C}$	5
		$T_C = 100^\circ\text{C}$	3
Pulsed Drain Current ²⁾	$I_{D,pulse}$	20	A
Gate-Source Voltage	V_{GS}	± 30	V
Single Pulse Avalanche Energy ³⁾	E_{AS}	180	mJ
MOSFET dv/dt Ruggedness, $V_{DS} = 0 \dots 480V$	dv/dt	5	V/ns
Power Dissipation For TO-220F	P_D	37.3	W
Power Dissipation For TO-252/220/251		48.3	
Continuous Diode Forward Current	I_S	5	A
Diode Pulsed Current ²⁾	$I_{S,pulse}$	20	
Operating Junction and Storage Temperature Range	T_J, T_{stg}	-55~+150	$^\circ\text{C}$

HRH5N50ADNx Thermal Resistance For TO-220F			
Parameter	Symbol	Value	Unit
Thermal Resistance, Junction-to-Case	R_{thJC}	3.35	$^\circ\text{C}/W$
Thermal Resistance, Junction-to-Ambient	R_{thJA}	80	

HRH5N50ADNx Thermal Resistance For TO-252/220/251			
Parameter	Symbol	Value	Unit
Thermal Resistance, Junction-to-Case	R_{thJC}	2.59	$^\circ\text{C}/W$
Thermal Resistance, Junction-to-Ambient	R_{thJA}	62	

Notes

- 1) Limited by maximum junction temperature.
- 2) Repetitive Rating: Pulse width limited by maximum junction temperature.
- 3) $L=10\text{mH}$, $I_D=5A$, Start $T_J=25^\circ\text{C}$



HRH5N50ADNx Electrical Characteristics $T_J = 25^\circ\text{C}$, unless otherwise noted						
Parameter	Symbol	Test Conditions	Value			Unit
			Min.	Typ.	Max.	
Static Characteristics						
Drain-Source Breakdown Voltage	$V_{(BR)DSS}$	$V_{GS} = 0V, I_D = 250\mu A$	500	--	--	V
Zero Gate Voltage Drain Current	I_{DSS}	$V_{DS} = 500V$ $V_{GS} = 0V, T_J = 25^\circ\text{C}$	--	--	1	μA
		$V_{DS} = 500V$, $V_{GS} = 0V, T_J = 150^\circ\text{C}$	--	--	100	
Gate-Source Leakage Current	I_{GSS}	$V_{GS} = \pm 30V$	--	--	± 100	nA
Gate-Source Threshold Voltage	$V_{GS(th)}$	$V_{DS} = V_{GS}, I_D = 250\mu A$	2	--	4	V
Drain-Source On-State-Resistance	$R_{DS(on)}$	$V_{GS} = 10V, I_D = 2.5A$	--	1.2	1.5	Ω
Gate Resistance	R_G	$f = 1.0\text{MHz}$ open drain	--	2.5	--	Ω
Dynamic Characteristics						
Input Capacitance	C_{iss}	$V_{GS} = 0V, V_{DS} = 25V$ $f = 1.0\text{MHz}$	--	488	--	μF
Output Capacitance	C_{oss}		--	60	--	
Reverse Transfer Capacitance	C_{rss}		--	7.2	--	
Total Gate Charge	Q_g	$V_{DD} = 400V, I_D = 5A$ $V_{GS} = 10V$	--	16.5	--	nC
Gate-Source Charge	Q_{gs}		--	3.8	--	
Gate-Drain Charge	Q_{gd}		--	5.6	--	
Gate Plateau Voltage	$V_{Plateau}$		--	4.6	--	V
Turn-on Delay Time	$t_{d(on)}$	$V_{DD} = 250V, I_D = 5A$ $R_G = 10\Omega, V_{GS} = 10V$	--	14	--	ns
Turn-on Rise Time	t_r		--	18	--	
Turn-off Delay Time	$t_{d(off)}$		--	32	--	
Turn-off Fall Time	t_f		--	11	--	
Drain-Source Body Diode Characteristics						
Body Diode Forward Voltage	V_{SD}	$T_J = 25^\circ\text{C}, I_{SD} = 5A$ $V_{GS} = 0V$	--	--	1.2	V
Reverse Recovery Time	t_{rr}	$V_R = 400V$ $I_F = 5A, di_F/dt = 100A/\mu s$	--	328	--	ns
Reverse Recovery Charge	Q_{rr}		--	1.6	--	μC



HRH5N50ADNx Typical Characteristics $T_J = 25^\circ\text{C}$, unless otherwise noted

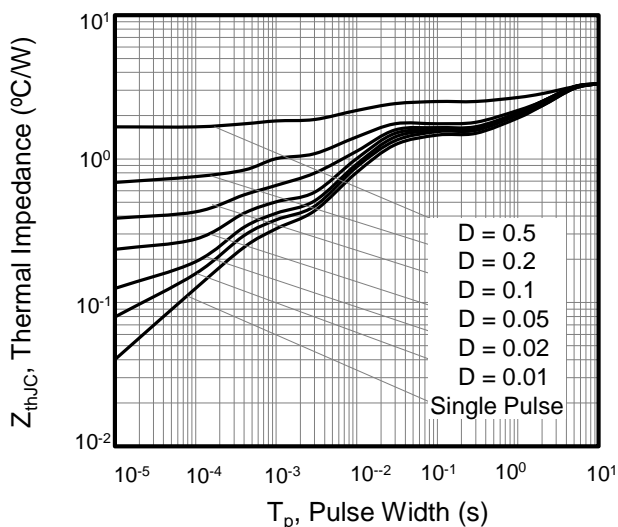

Figure 1. Transient Thermal Impedance For TO-220F

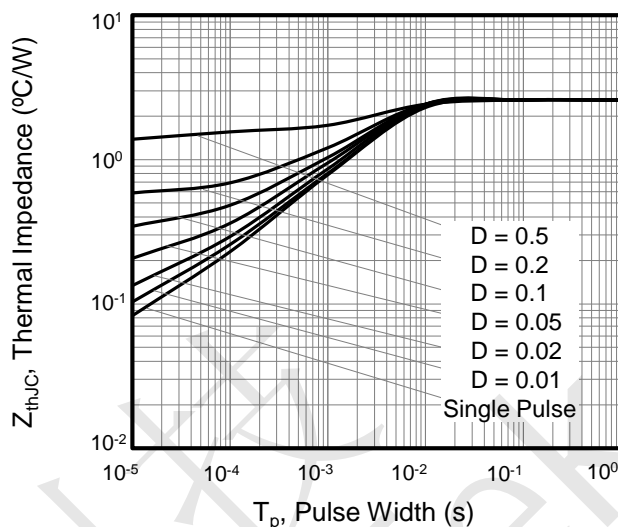

Figure 2. Transient Thermal Impedance For TO-252/220/251

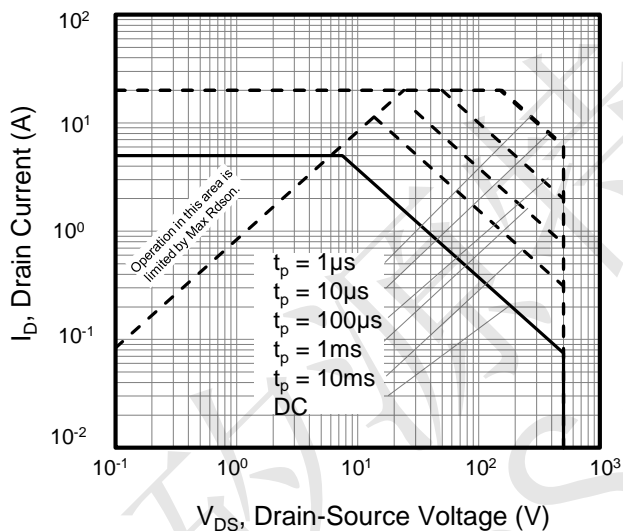

Figure 3. Safe Operation Area For TO-220F

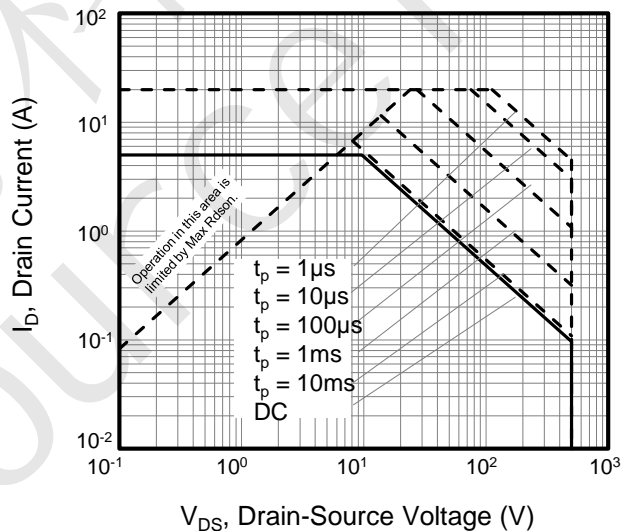

Figure 4. Safe Operation Area For TO-252/220/251

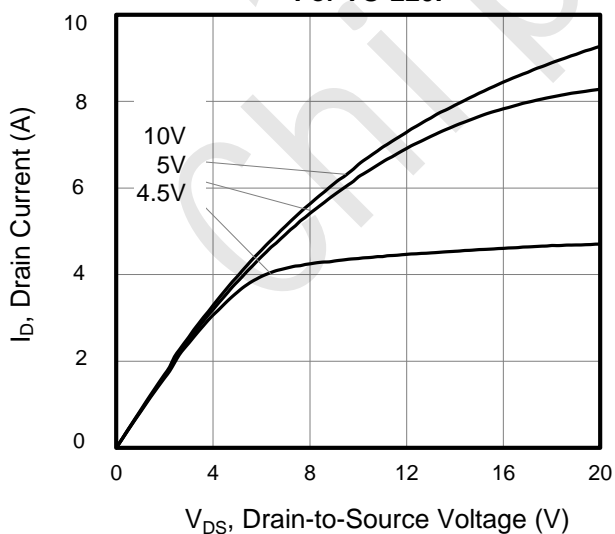

Figure 5. Output Characteristics

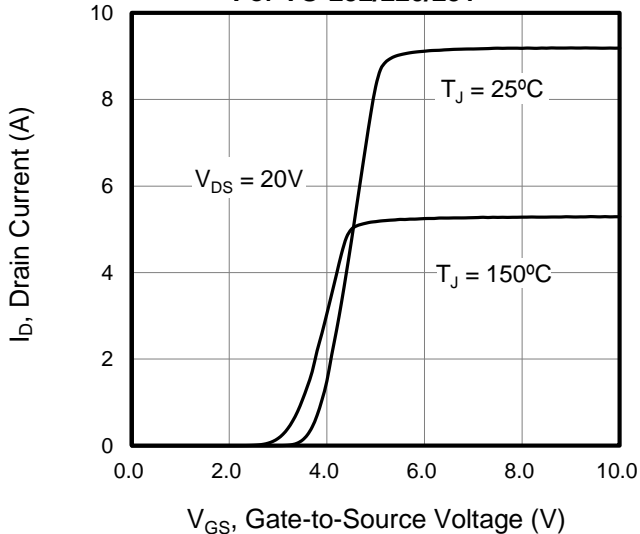

Figure 6. Transfer Characteristics



HRH5N50ADNx Typical Characteristics $T_J = 25^\circ\text{C}$, unless otherwise noted

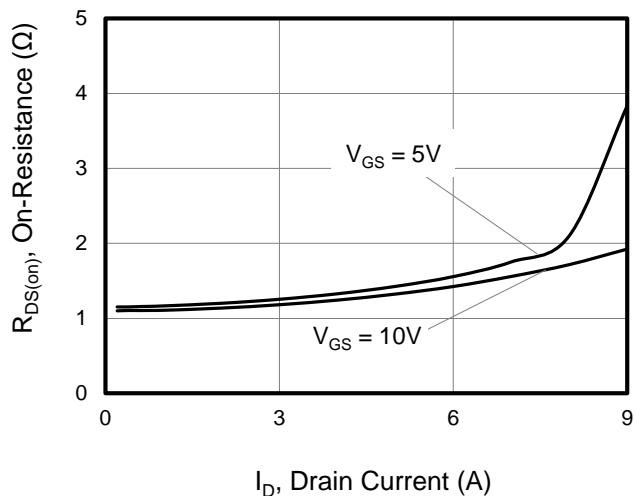

Figure 7. On-Resistance vs Drain Current

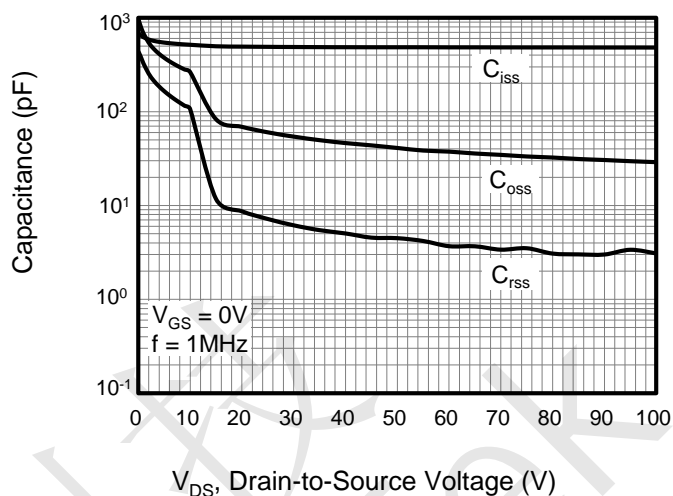

Figure 8. Capacitance

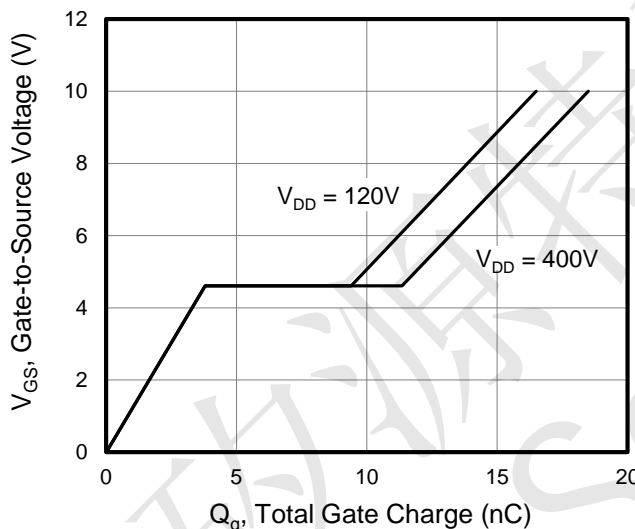

Figure 9. Gate Charge

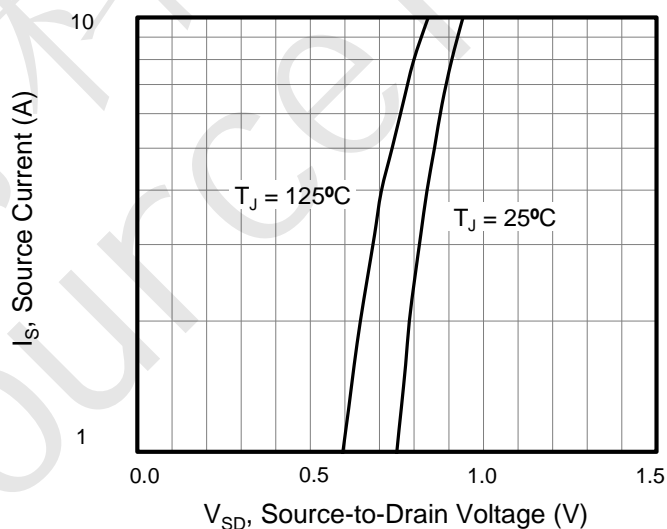

Figure 10. Body Diode Forward Voltage

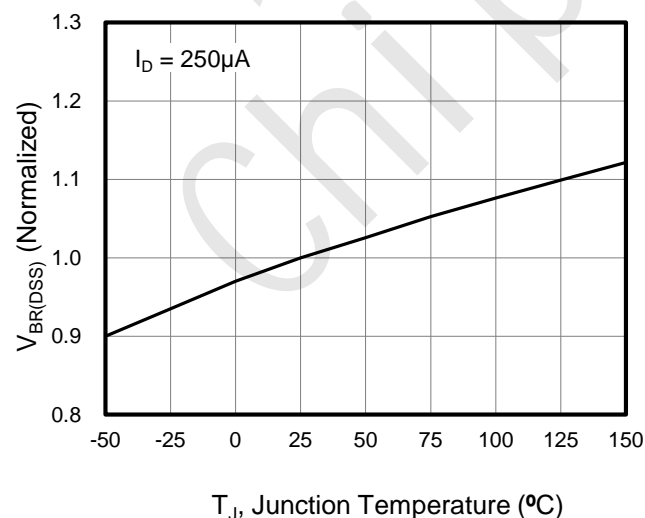

Figure 11. Breakdown Voltage vs Junction Temperature

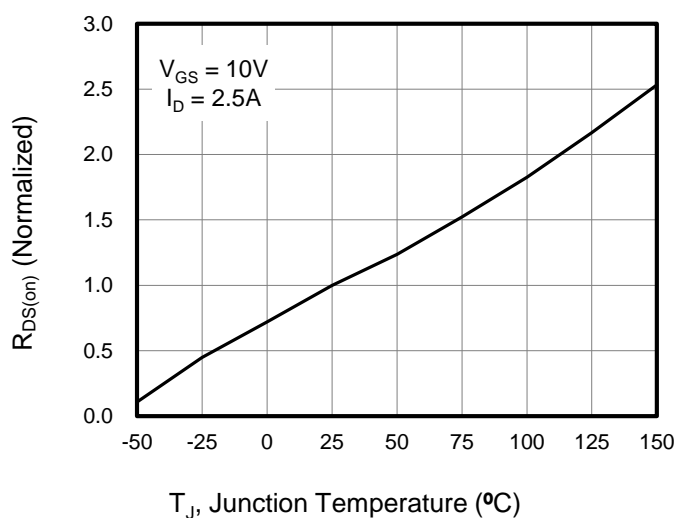

Figure 12. On-Resistance vs Temperature



Figure A: Gate Charge Test Circuit and Waveform

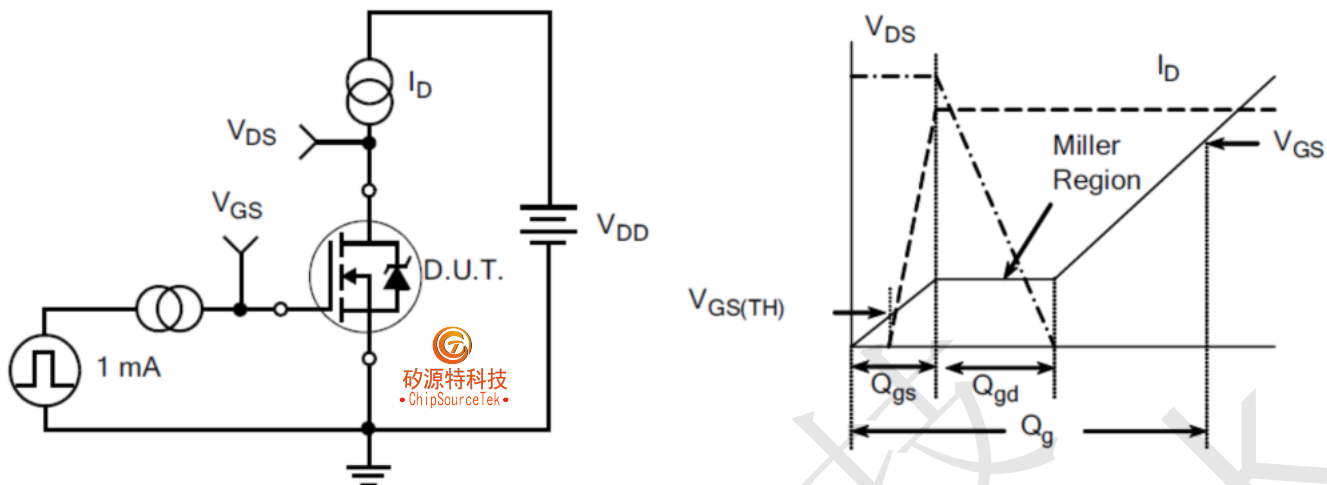

Figure B: Resistive Switching Test Circuit and Waveform

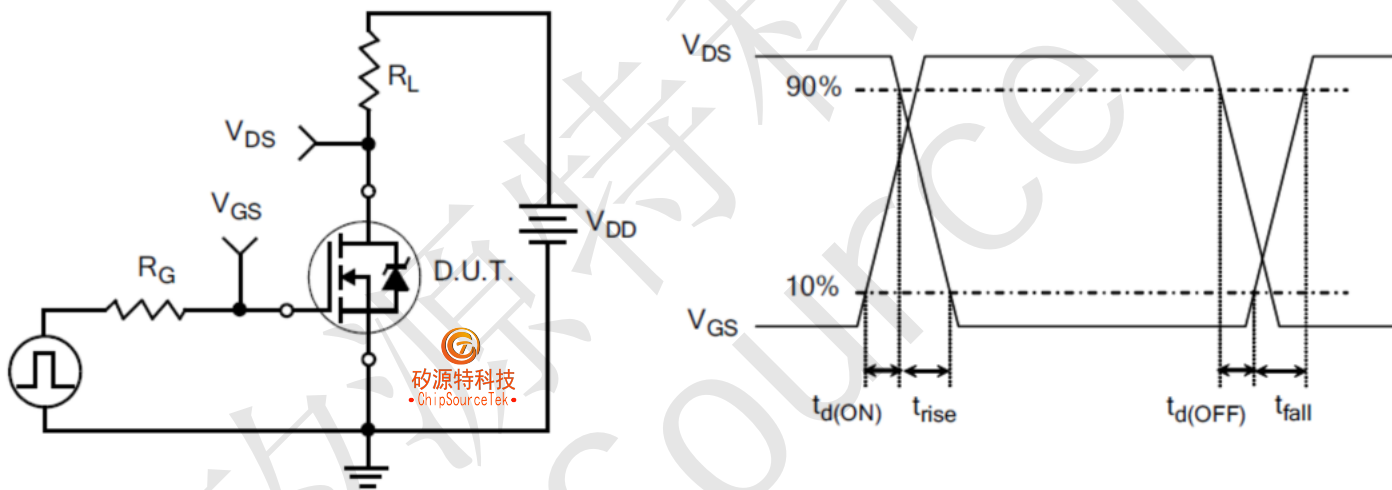
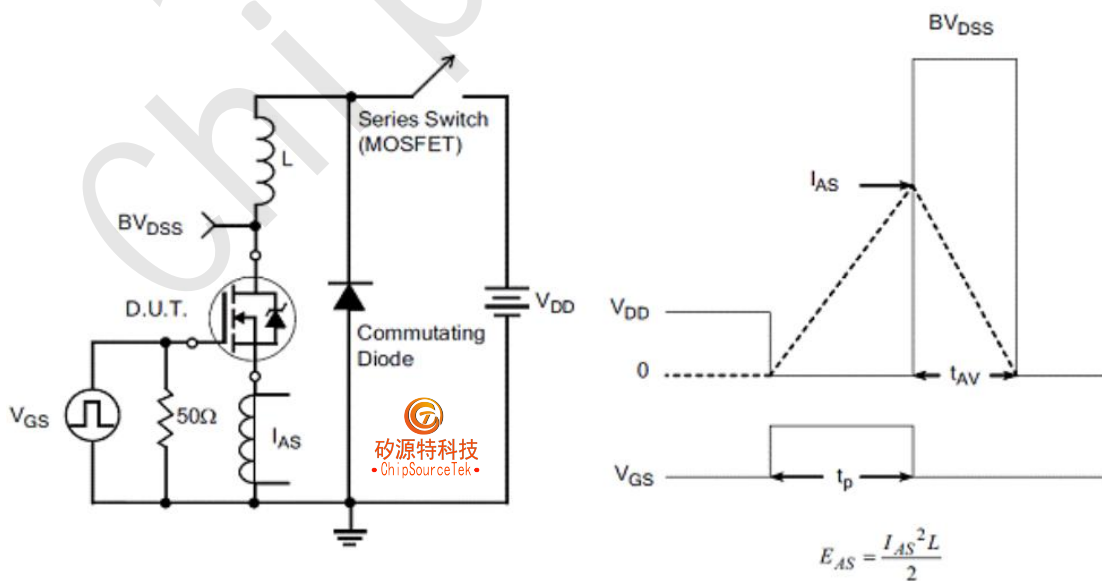
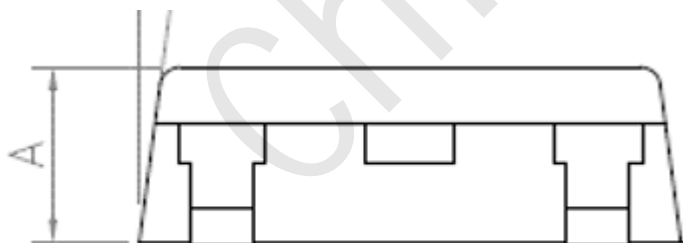
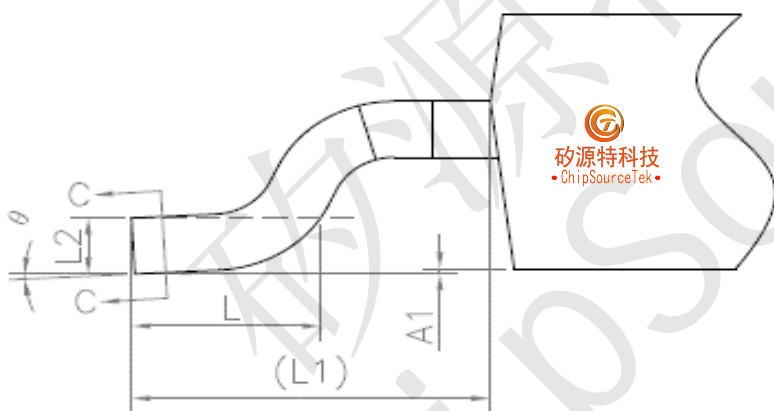
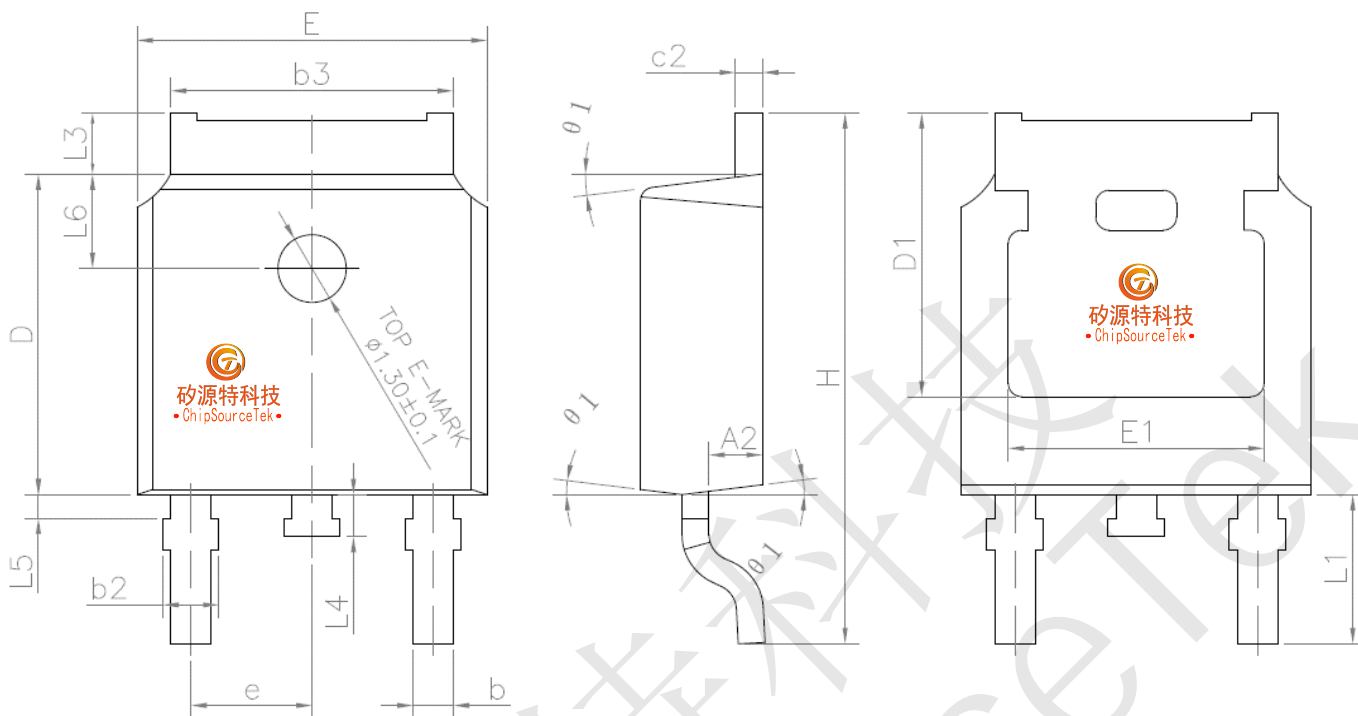

Figure C: Unclamped Inductive Switching Test Circuit and Waveform





HRH5N50ADNx Outlines TO-252 Package



SYMBOL	MIN	NOM	MAX
A	2.2	--	2.4
A1	0	--	0.2
A2	0.9	1.035	1.17
b	0.645	--	0.9
b3	5.13	5.326	5.46
c	0.43	--	0.61
c2	0.41	--	0.61
D	5.98	--	6.73
D1	5.2	--	--
E	5.8	--	6.73
E1	4.63	--	--
e	2.186	2.286	2.386
H	9.4	10.04	10.5
L	1.38	1.5	1.75
L1	2.6	2.872	3.1
L2	0.43	--	0.55
L3	0.88	--	1.28
L4	0.5	--	1
L5	0.15	--	0.75
L6	1.5	1.7	1.95
θ	0°	--	10°
θ1	5°	7°	9°



HRH5N50ADNx Outlines TO-220F Package

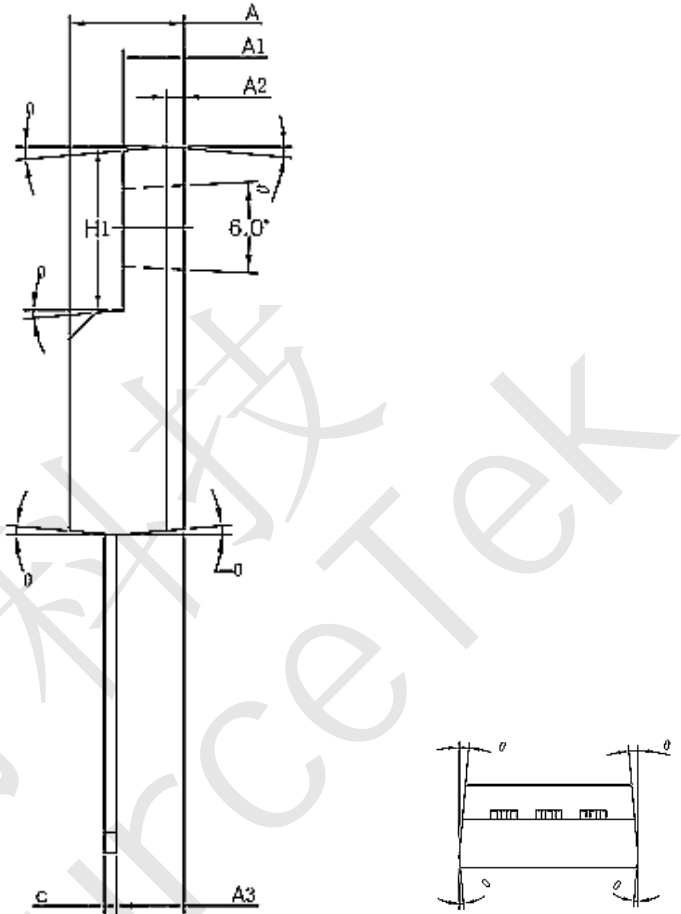
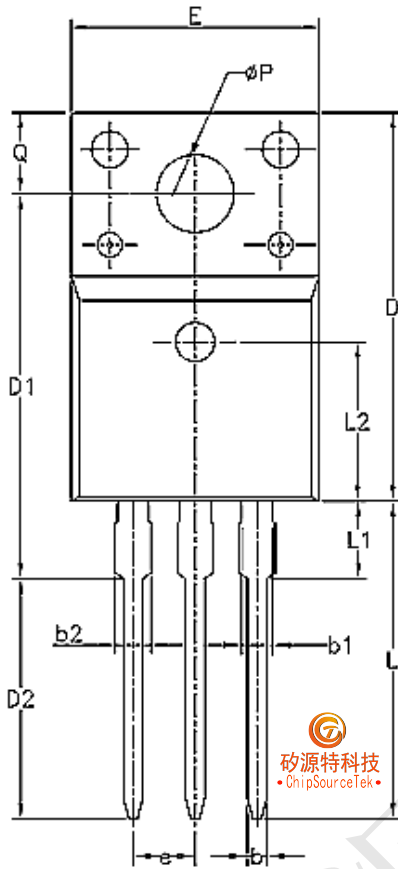

Unit:mm			
Symbol	Min.	Nom	Max.
A	4.50	4.70	4.83
A1	2.34	2.54	2.74
A2	0.70 REF		
A3	2.56	2.76	2.93
b	0.70	---	0.90
b1	1.18	---	1.38
b2	---	---	1.47
c	0.45	0.50	0.60
D	15.67	15.87	16.07
D1	15.55	15.75	15.95

Unit:mm			
Symbol	Min.	Nom	Max.
D2	9.60	9.80	10.0
E	9.96	10.16	10.36
e	2.54 BSC		
H1	6.48	6.68	6.88
L	12.68	12.98	13.28
L1	---	---	3.50
L2	6.50 REF		
ΦP	3.08	3.18	3.28
Q	3.20	---	3.40
θ	1°	3°	5°



HRH5N50ADNx Outlines TO-220 Package

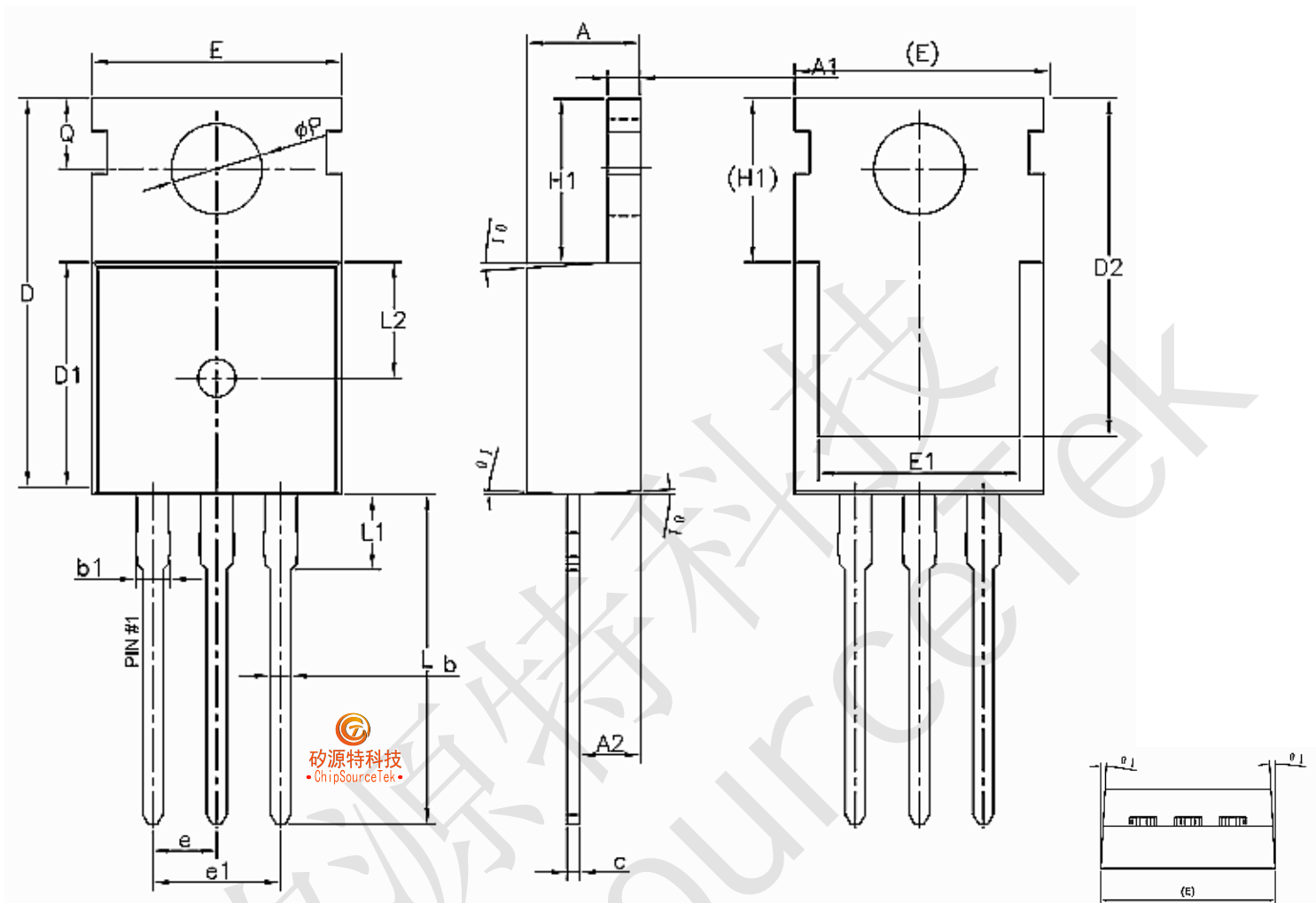

Unit:mm			
Symbol	Min.	Nom	Max.
A	4.40	4.50	4.60
A1	1.27	1.30	1.33
A2	2.30	2.40	2.50
b	0.70	---	0.90
b2	1.27	---	1.40
c	0.45	0.50	0.60
D	15.30	15.70	16.10
D1	9.10	9.20	9.30
D2	13.10	---	13.70
E	9.70	9.90	10.20

Unit:mm			
Symbol	Min.	Nom	Max.
E1	7.80	8.00	8.20
e	2.54 BSC		
e1	5.08 BSC		
H1	6.30	6.50	6.70
L	12.78	13.08	13.38
L1	---	---	3.50
L2	4.60 REF		
ΦP	3.55	3.60	3.65
Q	2.73	---	2.87
θ1	1°	3°	5°



HRH5N50ADNx Outlines TO-251 Package

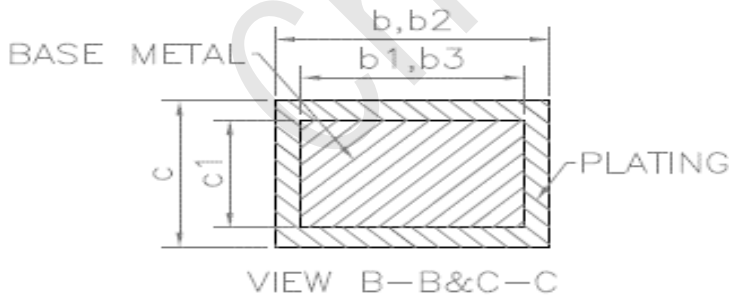
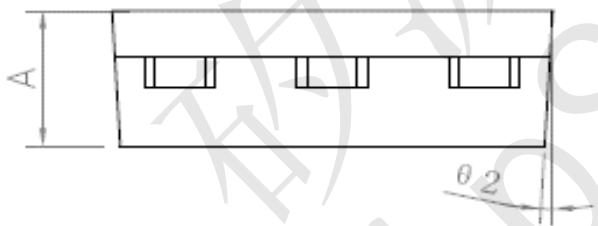
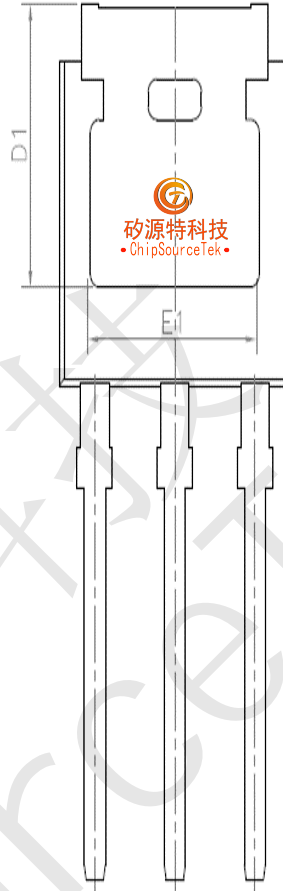
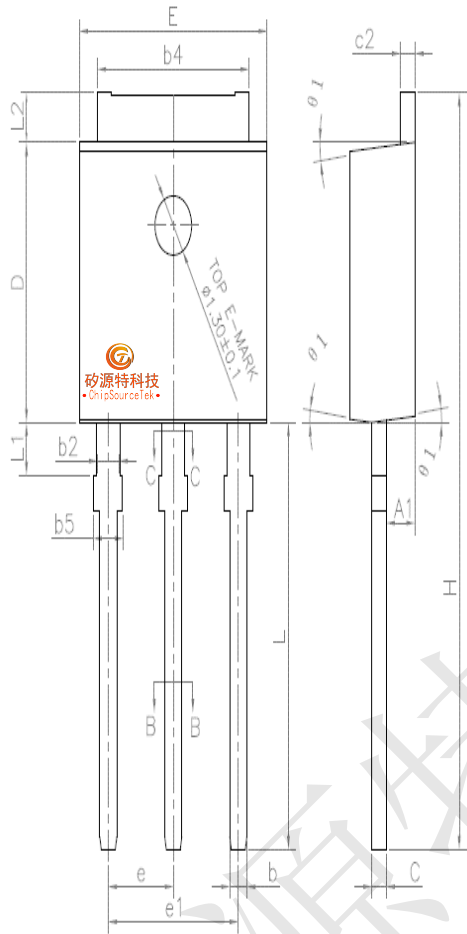

SYMBOL	MIN	NOM	MAX
A	2.2	2.3	2.35
A1	0.9	1.01	1.1
b	0.56	--	0.69
b1	0.55	0.6	0.65
b2	0.77	--	0.9
b3	0.76	0.81	0.86
b4	5.23	5.33	5.43
b5	--	--	1.05
c	0.46	--	0.59
c1	0.45	0.51	0.55
c2	0.46	--	0.59
D	6	6.1	6.2
D1	5.2	--	--
E	6.5	6.6	6.7
E1	4.6	4.83	5
e	2.24	2.29	2.34
e1	4.47	4.57	4.67
H	16.18	16.48	16.78
L	9	9.3	9.6
L1	0.95	1.16	1.35
L2	0.9	1.08	1.25
θ	3°	5°	7°
θ1	1°	3°	5°