



Microprocessor Oscillators

STANDARD STOCK FREQUENCIES

H Series 1.0 MHz-40.0 MHz

Modern semiconductor technology has made development and production of hybrid clock oscillators a logical advance in crystal manufacture. Optimum trade-offs can be determined when detailed information on crystal design and factors influencing their choice and performance are known. The availability of efficient divider circuitry increases the variety of options by allowing crystal frequencies to be chosen in ranges most advantageous for specific applications.

The stock oscillators are TTL & CMOS compatible and fit a DIP layout. Standard electrical specifications are shown. Variations can be made for special applications.

HS-380 Series oscillators provide output levels compatible with requirements of the Z80/80A/80B and 8000/8000A microprocessors.

THESE OSCILLATORS ARE AVAILABLE IN BOTH THRU-HOLE & SURFACE MOUNT CONFIGURATION

All NEL clock oscillators are hermetically sealed in resistance welded, all metal packages that are dry gas backfilled and mass spectrometer leak tested.

To order microprocessor oscillators, specify NEL Catalog Numbers from the table. The Catalog Number identifies the oscillator completely, including tolerance.

Example: H6250 fully defines an NEL stock oscillator at 4.000 MHz, $\pm 0.01\%$ from 0° to 70° C, which is CMOS and TTL compatible.

HS-100/HS-350 Series

FREQUENCY (MHz)	CATALOG NUMBER
1.000	H6050
1.2288	H6100
1.8432	H6150
2.000	H6160
2.4576	H6200
3.6864	H6225
4.000	H6250
4.096	H6275
4.9152	H6300
5.000	H6350
5.0688	H6400
6.000	H6450
6.144	H6475
7.3728	H6500
8.000	H6550
10.000	H6600
11.0592	H6625
12.000	H6650
16.000	H6700
16.384	H6750
18.432	H6800
19.6608	H6850
20.000	H6900
24.000	H6950
25.000	H7000
40.000	H7250

HS-380 Series

FREQUENCY (MHz)	CATALOG NUMBER
4.000	H8100

OVERALL TOLERANCE

$\pm 0.01\%$ 0° to + 70° C
inclusive of calibration & drift

Enclosure Dimensions, Output Waveform & Equivalent Load see pages 16, 17, 18, 32.



NEW PRODUCTS

In our continued effort to provide quality products to meet the needs of the changing electronics market, NEL is in the process of developing several new products.

Among these are:

TTL/CMOS Oscillator

Frequency range 70 to 100 MHz. User tolerance available from $\pm .005\%$.

3-State CMOS/TTL

Frequency range extended to 80MHz. User tolerance available from $\pm .005\%$.

Z80/8000/80A/80B Oscillator

Frequency range on HS-380/2890 Series extended to 40.0MHz. User tolerance available from $\pm .0025\%$.

Programmable Video Clock Generator

For use in the computer graphics, disk drive (zone locator) and fiber optics markets.

This product simplifies operations by using phase-locked loop techniques to generate, from the crystal oscillator, all the necessary clocks used in a typical graphics system.

OSCILLATOR METAL HALF PACK AND SURFACE MOUNT DIMENSIONS

HA Series

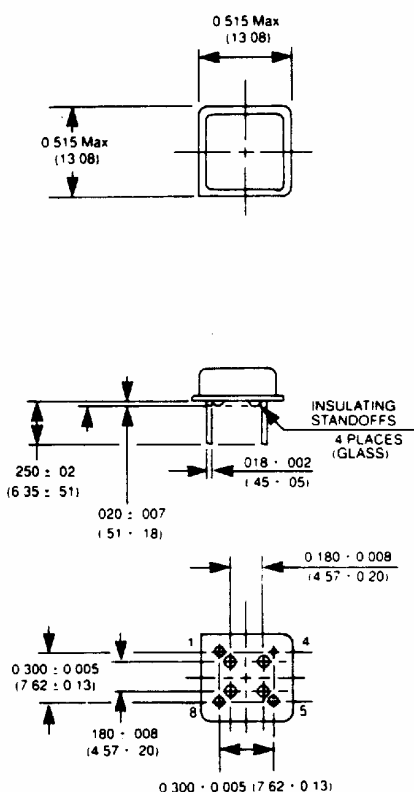

Pin number 4 connected to case.

The metal half pack oscillator is available in TTL, CMOS, and Z80 logics. See options on pages 17, 20, 29, and 33 for details.

SA Series

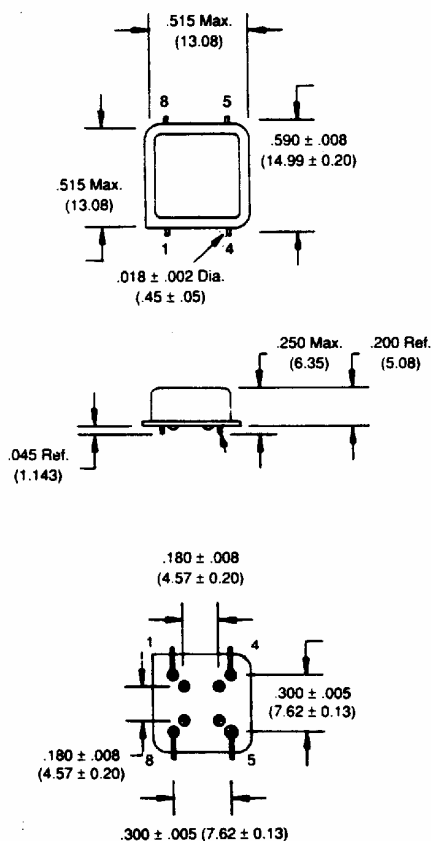

Pin number 4 connected to case.
Seating plane = $.005 \text{ Max.}$ (.127)
Wire leads to be formed to a 90° angle.

SM Series

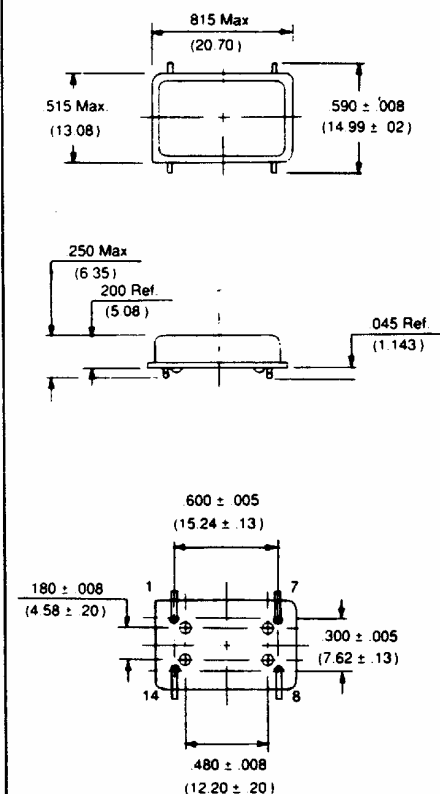

Pin number 7 connected to case.
Seating plane = $.005 \text{ Max.}$ (.127)
Wire leads to be formed to a 90° angle.

Dimensions are for reference only, inches (mm).