



H9435S

P-Channel Enhancement-Mode MOSFET (-30V, -5.3A)

Features

- $R_{DS(on)}=60m\Omega @ V_{GS}=-10V, I_D=-5.3A$
- $R_{DS(on)}=90m\Omega @ V_{GS}=-4.5V, I_D=-4.2A$
- Advanced Trench Process Technology
- High Density Cell Design for Ultra Low On-Resistance
- Fully Characterized Avalanche Voltage and Current
- Improved Shoot-Through FOM

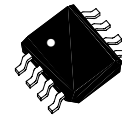

8-Lead Plastic **SO-8**
 Package Code: S

H9435S Symbol & Pin Assignment

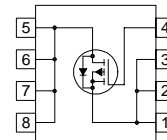

Pin 1 / 2 / 3: Source
 Pin 4: Gate
 Pin 5 / 6 / 7 / 8: Drain

Absolute Maximum Ratings ($T_A=25^\circ\text{C}$, unless otherwise noted)

Symbol	Parameter	Ratings	Units
V_{DS}	Drain-Source Voltage	-30	V
V_{GS}	Gate-Source Voltage	± 20	V
I_D	Drain Current (Continuous)	-5.3	A
I_{DM}	Drain Current (Pulsed) ^{*1}	-20	A
P_D	Total Power Dissipation @ $T_A=25^\circ\text{C}$	2.5	W
T_j, T_{stg}	Operating and Storage Temperature Range	-55 to +150	$^\circ\text{C}$
$R_{\theta JC}$	Thermal Resistance Junction to Case	30	$^\circ\text{C/W}$
$R_{\theta JA}$	Thermal Resistance Junction to Ambient (PCB mounted) ^{*2}	50	$^\circ\text{C/W}$

*1: Maximum DC current limited by the package

*2: 1-in² 2oz Cu PCB board



Electrical Characteristics (T_A=25°C, unless otherwise noted)

Symbol	Characteristic	Test Conditions	Min.	Typ.	Max.	Unit
--------	----------------	-----------------	------	------	------	------

• Static

BV _{DSS}	Drain-Source Breakdown Voltage	V _{GS} =0V, I _D =-250uA	30	-	-	V
R _{DS(on)}	Drain-Source On-State Resistance	V _{GS} =-4.5V, I _D =-4.2A	-	82	90	mΩ
		V _{GS} =-10V, I _D =-5.3A	-	50	60	
V _{GS(th)}	Gate Threshold Voltage	V _{DS} =V _{GS} , I _D =-250uA	-1	-	-3	V
I _{DSS}	Zero Gate Voltage Drain Current	V _{DS} =-24V, V _{GS} =0V	-	-	-1	uA
I _{GSS}	Gate-Body Leakage Current	V _{GS} =±20V, V _{DS} =0V	-	-	±100	nA
g _{FS}	Forward Transconductance	V _{DS} =-15V, I _D =-5.3A	4	7	-	S

• Dynamic

Q _g	Total Gate Charge	V _{DS} =-15V, I _D =-5.3A, V _{GS} =-10V	-	9.52	-	nC
Q _{gs}	Gate-Source Charge		-	3.43	-	
Q _{gd}	Gate-Drain Charge		-	1.71	-	
C _{iss}	Input Capacitance	V _{DS} =-15V, V _{GS} =0V, f=1MHz	-	551.57	-	PF
C _{oss}	Output Capacitance		-	90.96	-	
C _{rss}	Reverse Transfer Capacitance		-	60.79	-	
t _{d(on)}	Turn-on Delay Time	V _{DD} =10V, R _L =15Ω, I _D =-1A, V _{GEN} =-10V, R _G =6Ω	-	10.8	-	Ns
t _r	Turn-on Rise Time		-	2.33	-	
t _{d(off)}	Turn-off Delay Time		-	22.53	-	
t _f	Turn-off Fall Time		-	3.87	-	

• Drain-Source Diode Characteristics

I _S	Maximum Diode Forward Current		-	-	-1.9	A
V _{SD}	Drain-Source Diode Forward Voltage	V _{GS} =0V, I _S =-5.3A	-	-	-1.3	V

Note: Pulse Test: Pulse Width ≤300us, Duty Cycle ≤2%



HI-SINCERITY

MICROELECTRONICS CORP.

Spec. No. : MOS200509
 Issued Date : 2005.10.01
 Revised Date : 2005.10.06
 Page No. : 3/4

SO-8 Dimension

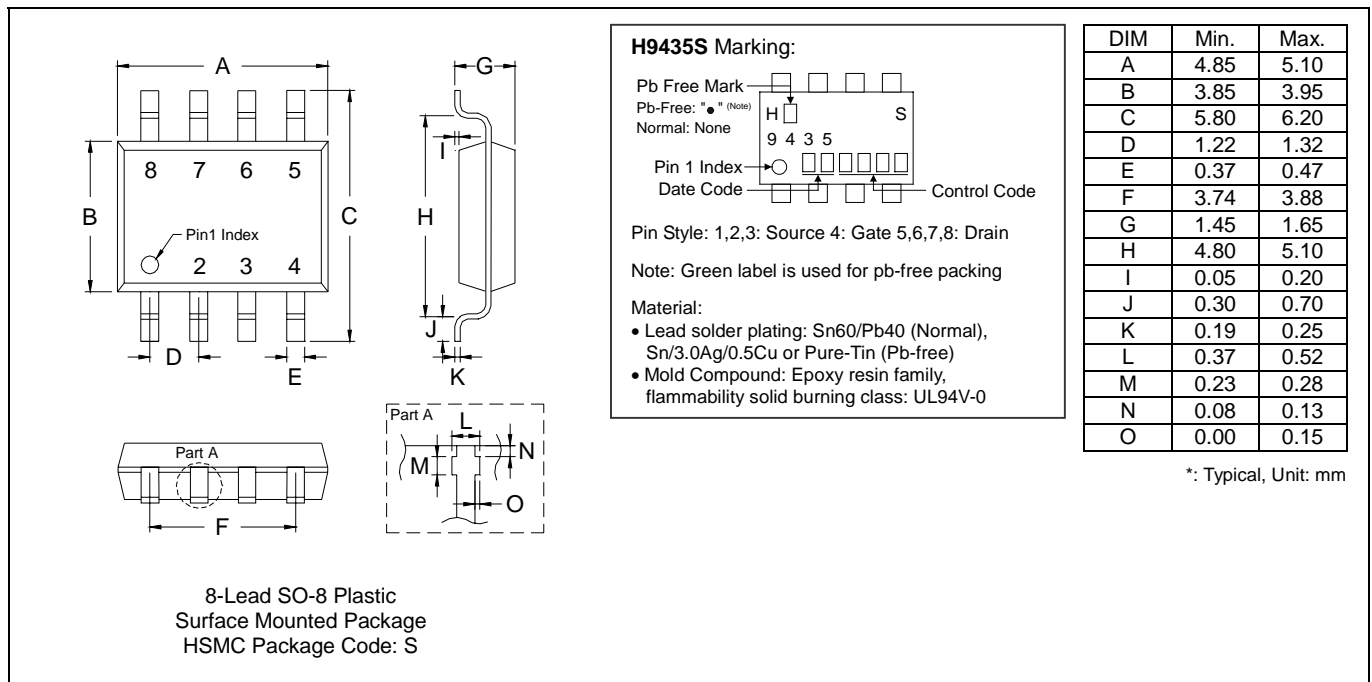

Important Notice:

- All rights are reserved. Reproduction in whole or in part is prohibited without the prior written approval of HSMC.
- HSMC reserves the right to make changes to its products without notice.
- HSMC semiconductor products are not warranted to be suitable for use in Life-Support Applications, or systems.**
- HSMC assumes no liability for any consequence of customer product design, infringement of patents, or application assistance.

Head Office And Factory:

- Head Office** (Hi-Sincerity Microelectronics Corp.): 10F., No. 61, Sec. 2, Chung-Shan N. Rd. Taipei Taiwan R.O.C.
 Tel: 886-2-25212056 Fax: 886-2-25632712, 25368454
- Factory 1:** No. 38, Kuang Fu S. Rd., Fu-Kou Hsin-Chu Industrial Park Hsin-Chu Taiwan. R.O.C
 Tel: 886-3-5983621~5 Fax: 886-3-5982931



Soldering Methods for HSMC's Products

1. Storage environment: Temperature=10°C~35°C Humidity=65%±15%
2. Reflow soldering of surface-mount devices

Figure 1: Temperature profile

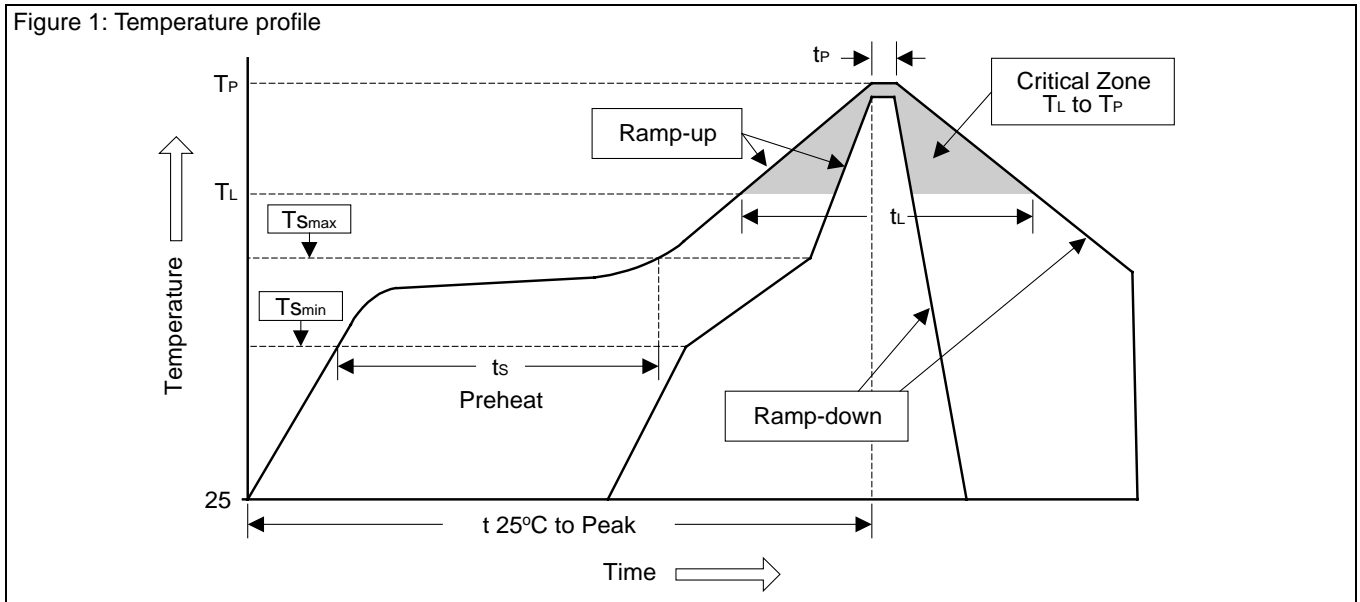

Profile Feature	Sn-Pb Eutectic Assembly	Pb-Free Assembly
Average ramp-up rate (T_L to T_P)	<3°C/sec	<3°C/sec
Preheat		
- Temperature Min (T_{Smin})	100°C	150°C
- Temperature Max (T_{Smax})	150°C	200°C
- Time (min to max) (t_s)	60~120 sec	60~180 sec
T_{Smax} to T_L		
- Ramp-up Rate	<3°C/sec	<3°C/sec
Time maintained above:		
- Temperature (T_L)	183°C	217°C
- Time (t_L)	60~150 sec	60~150 sec
Peak Temperature (T_P)	240°C +0/-5°C	260°C +0/-5°C
Time within 5°C of actual Peak Temperature (t_p)	10~30 sec	20~40 sec
Ramp-down Rate	<6°C/sec	<6°C/sec
Time 25°C to Peak Temperature	<6 minutes	<8 minutes

3. Flow (wave) soldering (solder dipping)

Products	Peak temperature	Dipping time
Pb devices.	245°C ±5°C	5sec ±1sec
Pb-Free devices.	260°C +0/-5°C	5sec ±1sec