

**12MHz, High Input Impedance,  
Operational Amplifier**

HA-2515 is a high performance operational amplifier which sets the standards for maximum slew rate, highest accuracy and widest bandwidths for internally compensated devices. In addition to excellent dynamic characteristics, this dielectrically isolated amplifier also offers low offset current and high input impedance.

The  $\pm 60V/\mu s$  slew rate and 250ns (0.1%) settling time of this amplifier is ideally suited for high speed D/A, A/D, and pulse amplification designs. HA-2515's superior 12MHz gain bandwidth and 1000kHz power bandwidth is extremely useful in RF and video applications. For accurate signal conditioning this amplifier also provides 10nA offset current, coupled with 100M $\Omega$  input impedance, and offset trim capability.

**Pinout**

**HA-2515 (PDIP)  
TOP VIEW**

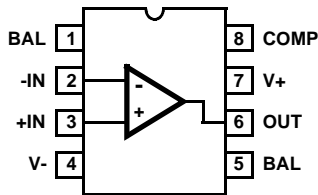

**Features**

- Slew Rate . . . . . 60V/ $\mu s$
- Fast Settling . . . . . 250ns
- Full Power Bandwidth . . . . . 1MHz
- Gain Bandwidth . . . . . 12MHz
- High Input Impedance . . . . . 100M $\Omega$
- Low Offset Current . . . . . 10nA
- Internally Compensated for Unity Gain Stability

**Applications**

- Data Acquisition Systems
- RF Amplifiers
- Video Amplifiers
- Signal Generators
- Pulse Amplification

**Part Number Information**

PART NUMBER	TEMP. RANGE (°C)	PACKAGE	PKG. NO.
HA3-2515-5	0 to 75	8 Ld PDIP	E8.3

**Absolute Maximum Ratings**

Voltage Between V+ and V- Terminals ..... 40V  
 Differential Input Voltage ..... 15V  
 Peak Output Current ..... 50mA

**Thermal Information**

Thermal Resistance (Typical, Note 1)  $\theta_{JA}$  (°C/W)  $\theta_{JC}$  (°C/W)  
 PDIP Package ..... 120 N/A  
 Maximum Junction Temperature (Plastic Package) ..... 150°C  
 Maximum Storage Temperature Range ..... -65°C to 150°C  
 Maximum Lead Temperature (Soldering 10s) ..... 300°C

**Operating Conditions**

Temperature Range  
 HA-2515-5 ..... 0°C to 75°C

*CAUTION: Stresses above those listed in "Absolute Maximum Ratings" may cause permanent damage to the device. This is a stress only rating and operation of the device at these or any other conditions above those indicated in the operational sections of this specification is not implied.*

**NOTE:**

- $\theta_{JA}$  is measured with the component mounted on a low effective thermal conductivity test board in free air. See Tech Brief TB379 for details.

**Electrical Specifications**  $V_{SUPPLY} = \pm 15V$

PARAMETER	TEMP (°C)	MIN	TYP	MAX	UNITS
<b>INPUT CHARACTERISTICS</b>					
Offset Voltage	25	-	5	10	mV
	Full	-	-	14	mV
Offset Voltage Average Drift	Full	-	30	-	$\mu V/^\circ C$
Bias Current	25	-	125	250	nA
	Full	-	-	500	nA
Offset Current	25	-	20	50	nA
	Full	-	-	100	nA
Input Resistance (Note 2)	25	40	100	-	M $\Omega$
Common Mode Range	Full	$\pm 10.0$	-	-	V
<b>TRANSFER CHARACTERISTICS</b>					
Large Signal Voltage Gain (Notes 3, 6)	25	7.5	15	-	kV/V
	Full	5	-	-	kV/V
Common Mode Rejection Ratio (Note 4)	Full	74	90	-	dB
Gain Bandwidth Product (Note 5)	25	-	12	-	MHz
<b>OUTPUT CHARACTERISTICS</b>					
Output Voltage Swing (Note 3)	Full	$\pm 10.0$	$\pm 12.0$	-	V
Output Current (Note 6)	25	$\pm 10$	$\pm 20$	-	mA
Full Power Bandwidth (Notes 6, 11)	25	600	1000	-	kHz
<b>TRANSIENT RESPONSE</b>					
Rise Time (Notes 3, 7, 8, 9)	25	-	25	50	ns
Overshoot (Notes 3, 7, 8, 9)	25	-	25	50	%
Slew Rate (Notes 3, 7, 9, 12)	25	$\pm 40$	$\pm 60$	-	V/ $\mu s$
Settling Time to 0.1% (Notes 3, 7, 9, 12)	25	-	0.25	-	$\mu s$
<b>POWER SUPPLY CHARACTERISTICS</b>					
Supply Current	25	-	4	6	mA
Power Supply Rejection Ratio (Note 10)	Full	74	90	-	dB

**NOTES:**

- This parameter value is based on design calculations.
- $R_L = 2k\Omega$ .
- $V_{CM} = \pm 10V$
- $A_V > 10$ .
- $V_O = \pm 10V$ .
- $C_L = 50pF$ .
- $V_O = \pm 200mV$ .
- See Transient Response Test Circuits and Waveforms.
- $\Delta V = \pm 5V$ .
- Full Power Bandwidth guaranteed based on slew rate measurement using:  $FPBW = Slew\ Rate / 2\pi V_{PEAK}$ .
- $V_{OUT} = \pm 5V$ .

Test Circuits and Waveforms

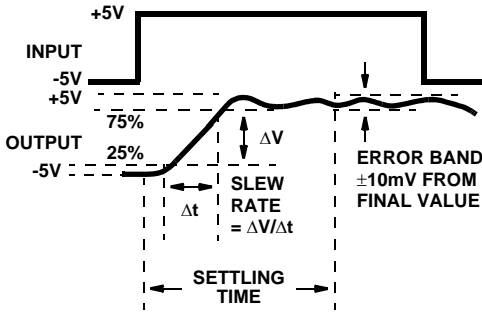
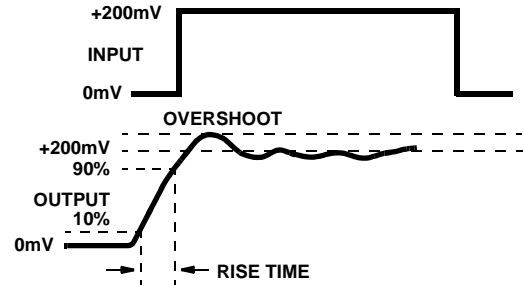

FIGURE 1. SLEW RATE AND SETTling TIME



NOTE: Measured on both positive and negative transitions from 0V to +200mV and 0V to -200mV at the output.

FIGURE 2. TRANSIENT RESPONSE

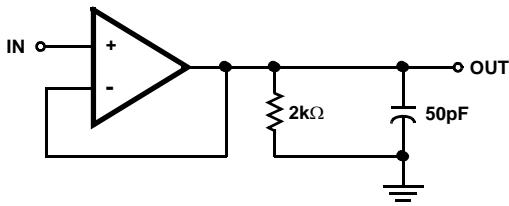
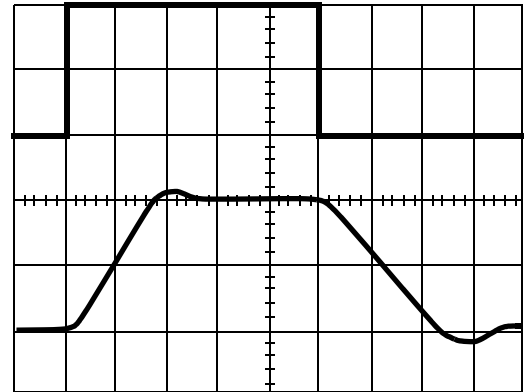
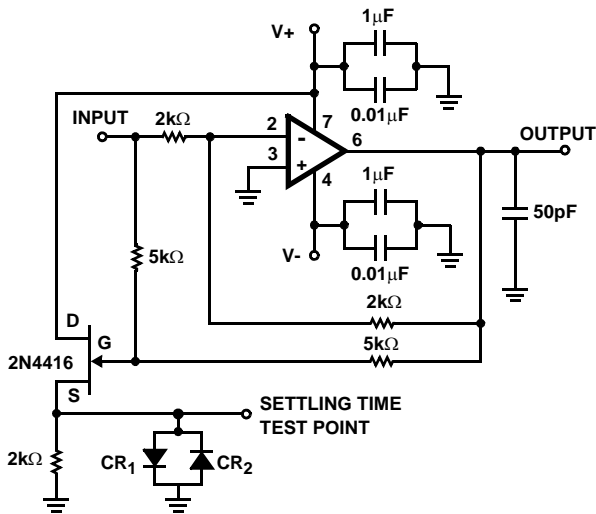

FIGURE 3. SLEW RATE AND TRANSIENT RESPONSE



$R_L = 2k\Omega$ ,  $C_L = 50pF$  Vertical = 5V/Div.  
Upper Trace: Input Horizontal = 200ns/Div.  
Lower Trace: Output  $T_A = 25^\circ C$ ,  $V_S = \pm 15V$

FIGURE 4. VOLTAGE FOLLOWER PULSE RESPONSE



NOTES:

- 13.  $A_V = -1$ .
- 14. Feedback and summing resistor ratios should be 0.1% matched.
- 15. Clipping diodes  $CR_1$  and  $CR_2$  are optional. HP5082-2810 recommended.

FIGURE 5. SETTling TIME TEST CIRCUIT

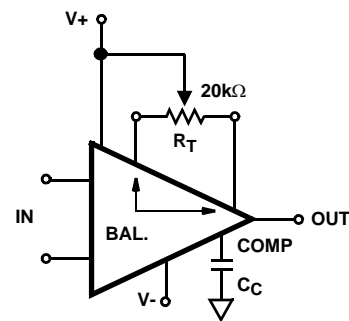

NOTE: Tested offset adjustment range is  $IVOS + 1mV$  minimum referred to output. Typical ranges are  $\pm 6mV$  with  $R_T = 20k\Omega$ .

FIGURE 6. SUGGESTED  $V_{OS}$  ADJUSTMENT AND COMPENSATION HOOK UP

Schematic

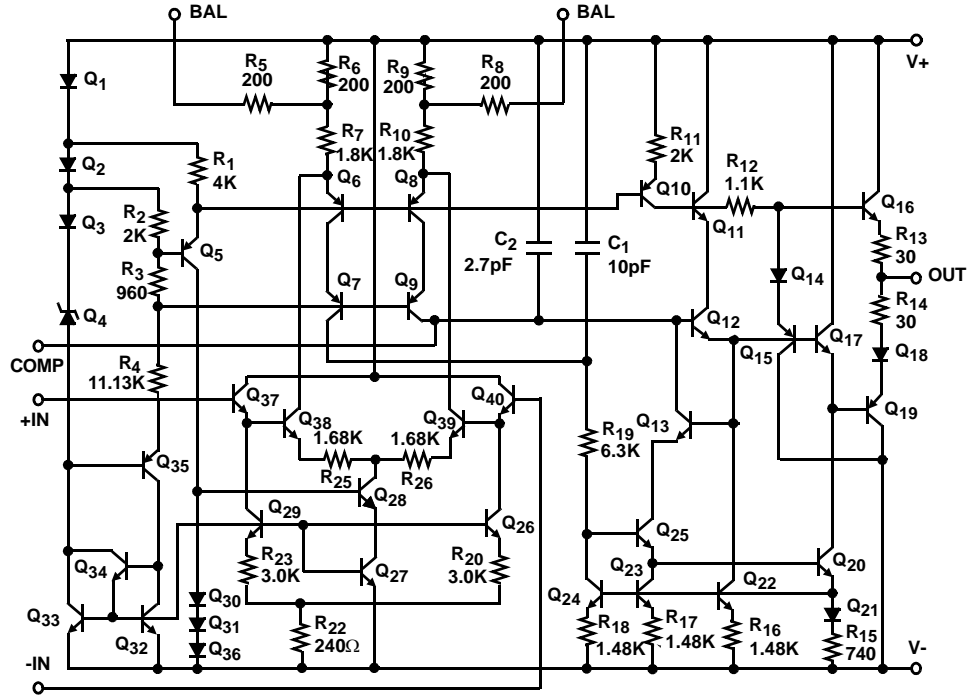

Typical Performance Curves

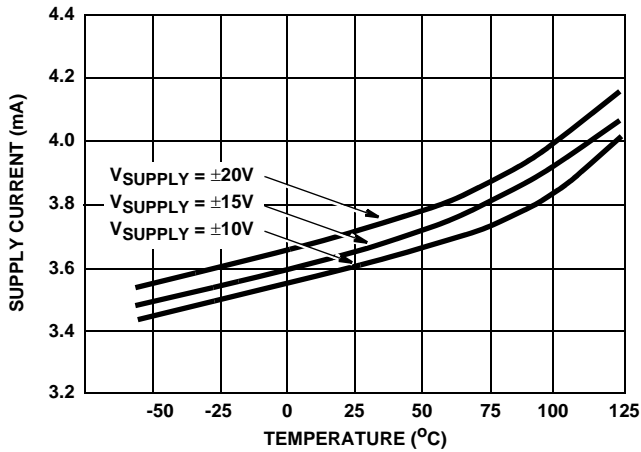

FIGURE 7. POWER SUPPLY CURRENT vs TEMPERATURE

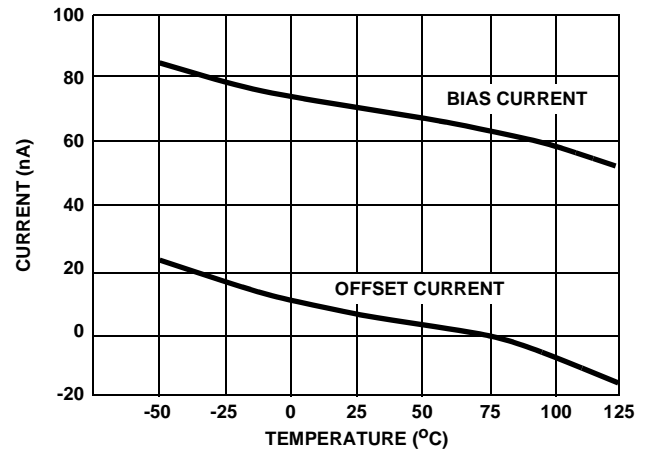

FIGURE 8. INPUT BIAS AND OFFSET CURRENT vs TEMPERATURE

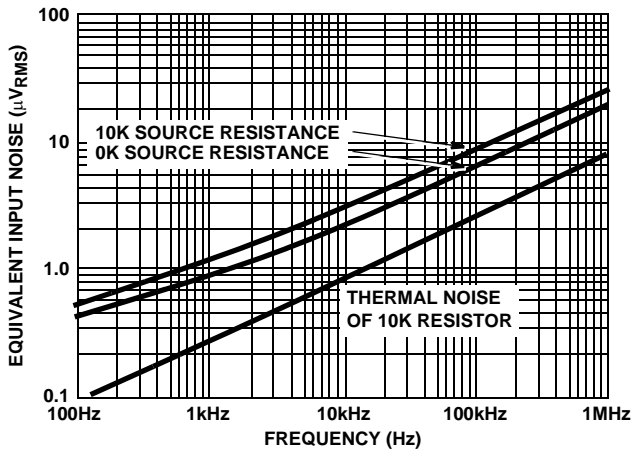

FIGURE 9. EQUIVALENT INPUT NOISE vs BANDWIDTH (WITH 10Hz HIGH PASS FILTER)

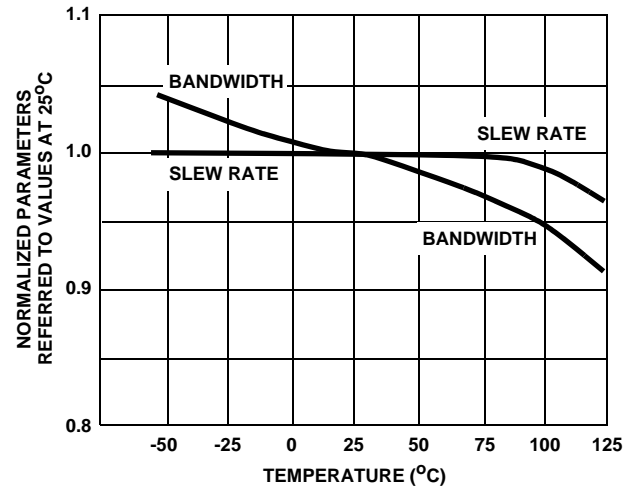

FIGURE 10. NORMALIZED AC PARAMETERS vs TEMPERATURE

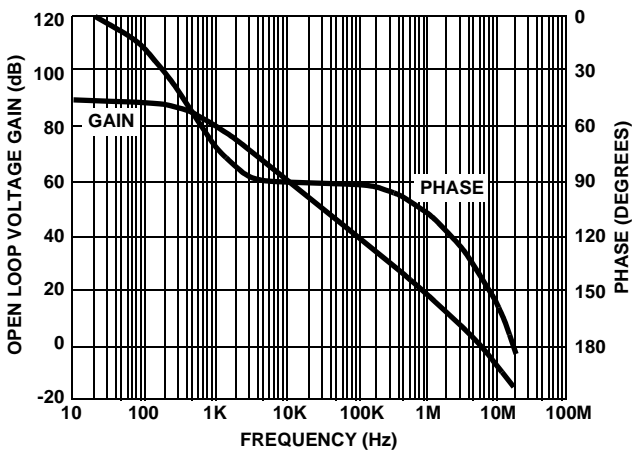

FIGURE 11. OPEN LOOP GAIN AND PHASE RESPONSE

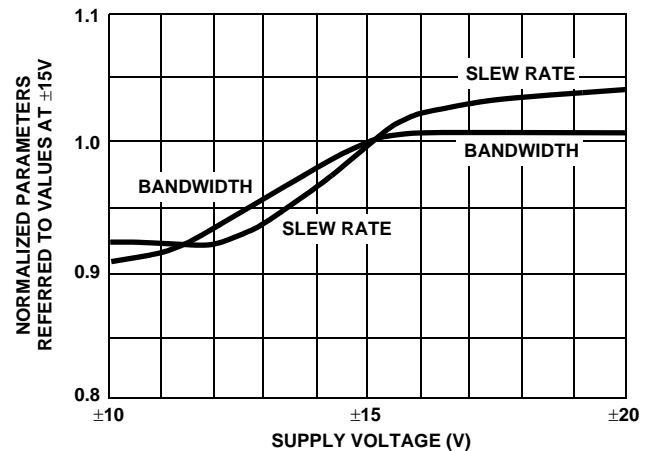

FIGURE 12. NORMALIZED AC PARAMETERS vs SUPPLY VOLTAGE AT 25°C

Typical Performance Curves (Continued)

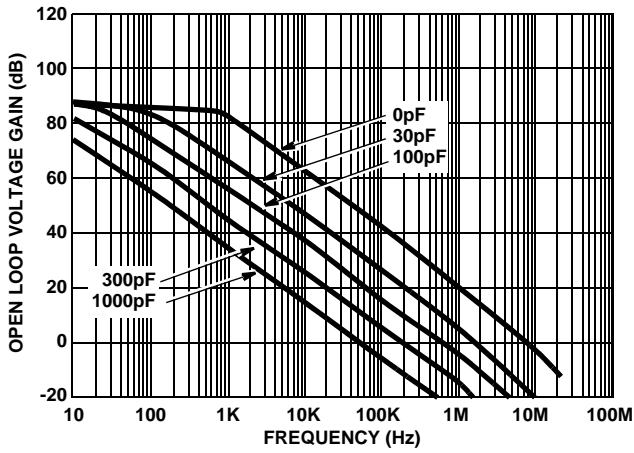

FIGURE 13. OPEN LOOP GAIN RESPONSE FOR VARIOUS VALUES OF CAPACITORS FROM COMPENSATION PIN TO GROUND

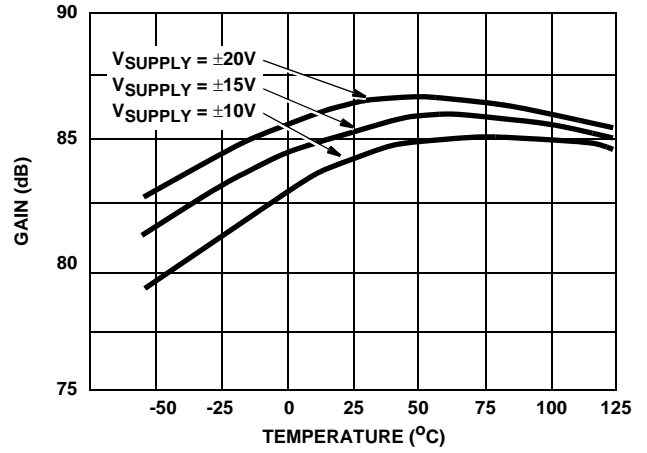

FIGURE 14. OPEN LOOP VOLTAGE GAIN vs TEMPERATURE

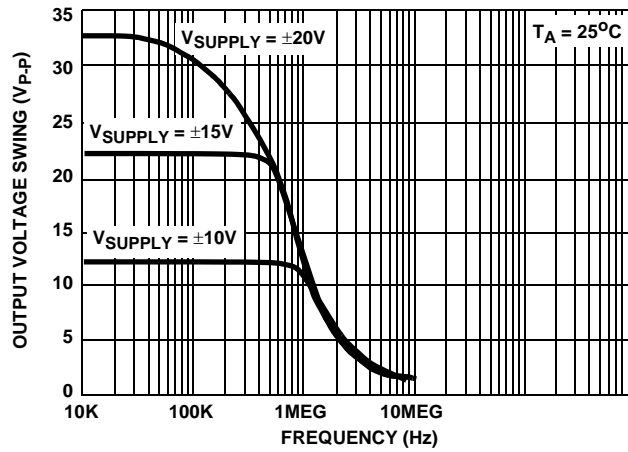

FIGURE 15. OUTPUT VOLTAGE SWING vs FREQUENCY

**Die Characteristics**

**DIE DIMENSIONS:**

65 mils x 57 mils x 19 mils  
 1650µm x 1450µm x 483µm

**METALLIZATION:**

Type: Al, 1% Cu  
 Thickness: 16kÅ ±2kÅ

**PASSIVATION:**

Type: Nitride (Si<sub>3</sub>N<sub>4</sub>) over Silox (SiO<sub>2</sub>, 5% Phos.)  
 Silox Thickness: 12kÅ ±2kÅ  
 Nitride Thickness: 3.5kÅ ±1.5kÅ

**SUBSTRATE POTENTIAL (Powered Up):**

Unbiased

**TRANSISTOR COUNT:**

40

**PROCESS:**

Bipolar Dielectric Isolation

**Metallization Mask Layout**

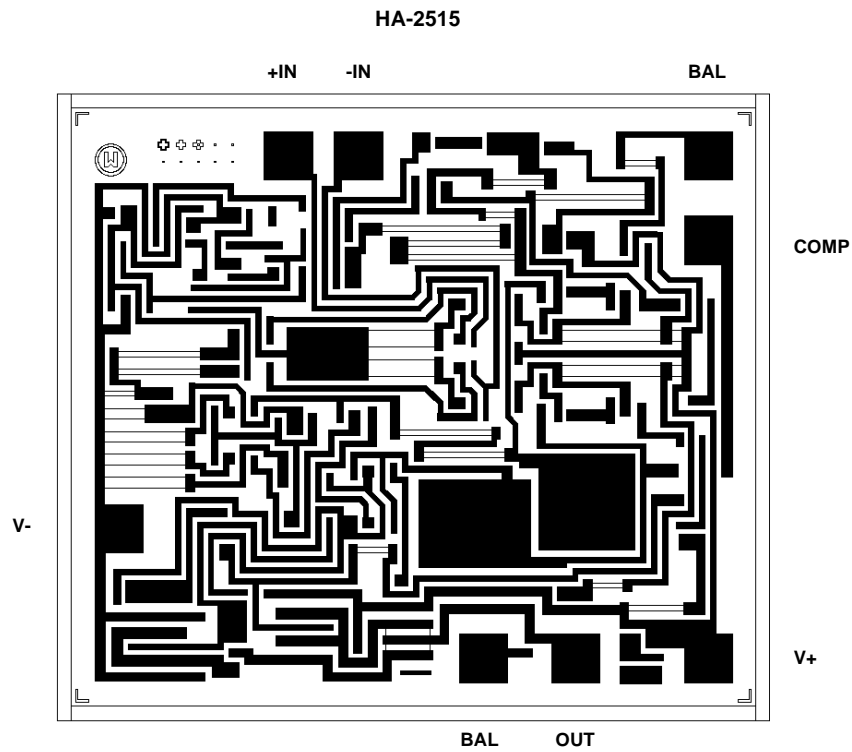

All Intersil U.S. products are manufactured, assembled and tested utilizing ISO9000 quality systems.  
 Intersil Corporation's quality certifications can be viewed at [www.intersil.com/design/quality](http://www.intersil.com/design/quality)

*Intersil products are sold by description only. Intersil Corporation reserves the right to make changes in circuit design, software and/or specifications at any time without notice. Accordingly, the reader is cautioned to verify that data sheets are current before placing orders. Information furnished by Intersil is believed to be accurate and reliable. However, no responsibility is assumed by Intersil or its subsidiaries for its use; nor for any infringements of patents or other rights of third parties which may result from its use. No license is granted by implication or otherwise under any patent or patent rights of Intersil or its subsidiaries.*

For information regarding Intersil Corporation and its products, see [www.intersil.com](http://www.intersil.com)

Dual-In-Line Plastic Packages (PDIP)

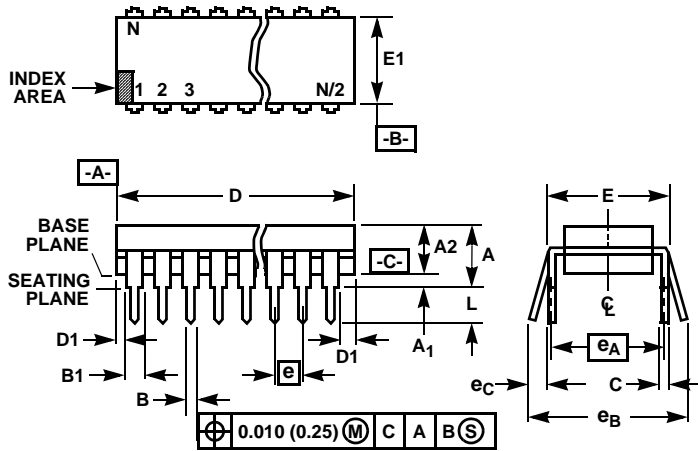

NOTES:

1. Controlling Dimensions: INCH. In case of conflict between English and Metric dimensions, the inch dimensions control.
2. Dimensioning and tolerancing per ANSI Y14.5M-1982.
3. Symbols are defined in the "MO Series Symbol List" in Section 2.2 of Publication No. 95.
4. Dimensions A, A1 and L are measured with the package seated in JEDEC seating plane gauge GS-3.
5. D, D1, and E1 dimensions do not include mold flash or protrusions. Mold flash or protrusions shall not exceed 0.010 inch (0.25mm).
6. E and e<sub>A</sub> are measured with the leads constrained to be perpendicular to datum -C-.
7. e<sub>B</sub> and e<sub>C</sub> are measured at the lead tips with the leads unconstrained. e<sub>C</sub> must be zero or greater.
8. B1 maximum dimensions do not include dambar protrusions. Dambar protrusions shall not exceed 0.010 inch (0.25mm).
9. N is the maximum number of terminal positions.
10. Corner leads (1, N, N/2 and N/2 + 1) for E8.3, E16.3, E18.3, E28.3, E42.6 will have a B1 dimension of 0.030 - 0.045 inch (0.76 - 1.14mm).

E8.3 (JEDEC MS-001-BA ISSUE D)  
8 LEAD DUAL-IN-LINE PLASTIC PACKAGE

SYMBOL	INCHES		MILLIMETERS		NOTES
	MIN	MAX	MIN	MAX	
A	-	0.210	-	5.33	4
A1	0.015	-	0.39	-	4
A2	0.115	0.195	2.93	4.95	-
B	0.014	0.022	0.356	0.558	-
B1	0.045	0.070	1.15	1.77	8, 10
C	0.008	0.014	0.204	0.355	-
D	0.355	0.400	9.01	10.16	5
D1	0.005	-	0.13	-	5
E	0.300	0.325	7.62	8.25	6
E1	0.240	0.280	6.10	7.11	5
e	0.100 BSC		2.54 BSC		-
e <sub>A</sub>	0.300 BSC		7.62 BSC		6
e <sub>B</sub>	-	0.430	-	10.92	7
L	0.115	0.150	2.93	3.81	4
N	8		8		9

Rev. 0 12/93