

HA11539NT

T-77-0705

Interface of Tuning System for Color TV and VCR

The HA11539NT is a multi-function IC, it provides several peripheral circuits associated with Color TV and VCR Remote Control Tuning Systems.

Functions

- Tuner peripheral circuit
 - 2 input 4 output band switch
 - Pulse amp. for AFS switch built-in
- Power supply circuit
 - +5 V power supply for tuner microcomputer
 - Reset pulse output for tuner microcomputer
 - Power supply relay control output
- Tuner microcomputer peripheral circuit
 - Buffer amp. for audio control
 - Wave shaper circuit for AC timer

Features

- Integrated remote control diode preamp. means that no IC shielding is required.
- Volume control characteristics are easily adjusted using the integrated push-pull output buffer amp.
- AC power supply wave shaper with hysteresis built-in.

Pin Arrangement

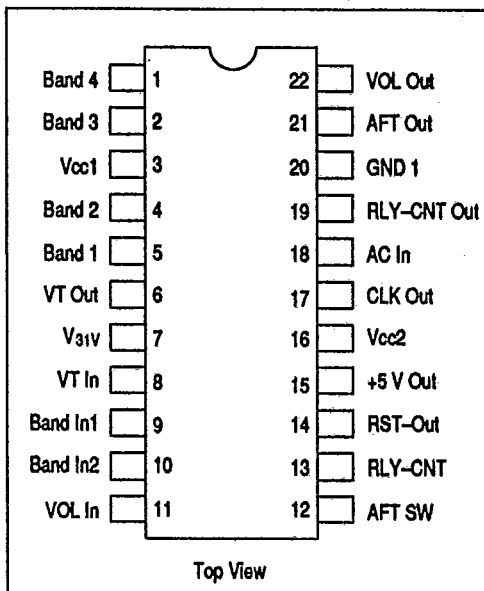

Ordering Information

Type No.	Package
HA11539NT	DP-22S



Block Diagram

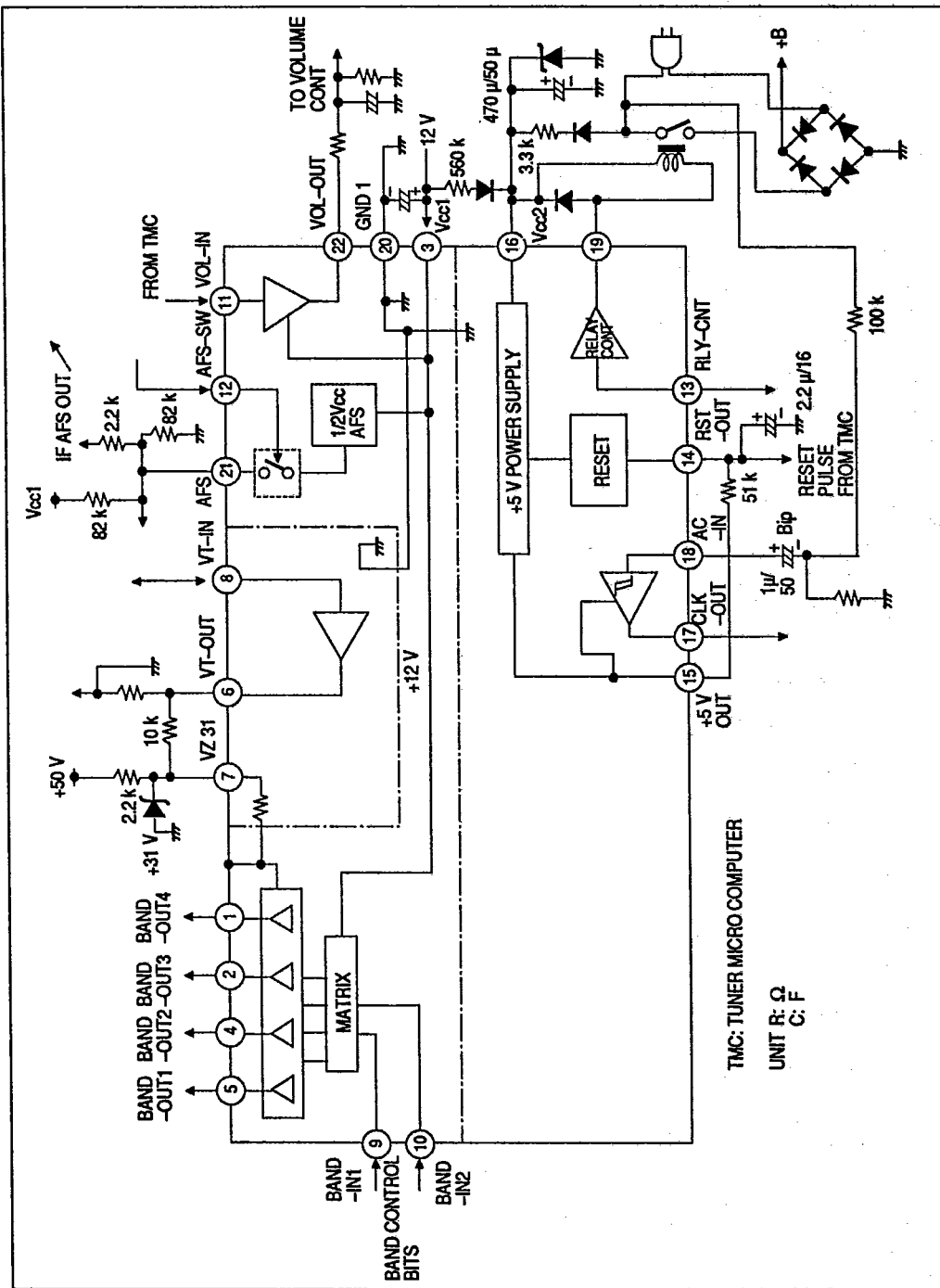

HA11539NT

T-77-07-05

Table 1 Absolute Maximum Ratings (Ta = 25 °C)

Item	Symbol	Rating	Unit	Notes
Power supply voltage 1	Vcc	15	V	1
Power supply voltage 2	Vz31	35	V	
Open collector voltage 1	Vcop1	-0.5 to +14.4	V	
Open collector voltage 2	Vcop2	-0.5 to +35	V	
Band source current	Io	-60	mA	2
5 V reference source current	Io	-25	mA	
Input terminal voltage	Vi	5.5	V	3
Open collector sink current 1	Icop1	80	mA	
Open collector sink current 2	Icop2	20	mA	
Power dissipation	P _T	750	mW	
Operating temperature	Topr	-20 to +65	°C	

- Notes) 1. Vcc1, Vcc2, Vcc3
 2. Io1(B), Io2(B), Io3(B), Io4(B)
 3. Vi1(B), Vi2(B), Vi(A), Vi(P), Vi(RL), Vi(RS), Vi(T)

Table 2 Electrical Characteristics (Ta = 25 °C, Vcc = 12 V)

Item	Symbol	Min	Typ	Max	Unit	Terminal
Operating voltage range	Vcc	8	12	13	V	3
Supply current 1	Icc1	5	8	11	mA	3
Supply current 2	Icc2	20	25	30	mA	16
Band switch output high voltage	VoH(B)	11.4	11.8	—	V	1, 2, 4, 5
Band switch input threshold voltage	VTH(B)	0.8	2.4	3.0	V	9, 10
AFC switch input threshold voltage	VTH(A)	0.8	1.35	2.0	V	12
AFC switch output voltage	Vo(A)	5.7	6.0	6.3	V	21



HA11539NT

T-77-07-05

Electrical Characteristics (Ta = 25 °C, Vcc = 12 V) (cont)

Volume control input threshold voltage	V _{TH(V)}	0.8	2.5	3.0	V	12
5 volts reference output voltage	V _{o5}	4.5	5.0	5.5	V	15
Relay control input 1 threshold voltage	V _{TR(RL)}	0.8	1.3	3.0	V	13
Reset release start supply voltage	V _{CC2(RS)}	5.8	6.5	7.0	V	16
AC input terminal open voltage	V _{IN2}	2.1	2.5	2.9	V	18
Input signal high threshold voltage	V _{TH(H)}	+0.25	+0.5	+0.75	V	18
Input signal low threshold voltage	V _{TH(L)}	-0.65	-0.5	-0.35	V	18
Pulse amp input threshold voltage	V _{TH(P)}	0.3	0.82	1.5	V	8

Functional Description

Tuner Peripheral Circuits

Band Switch

2 inputs 4 outputs band switch built-in.

- The truth table is as follows.

Input		Output			
1	2	1	2	3	4
9 pin	5 pin	5 pin	4 pin	2 pin	1 pin
L	L	H	Z	Z	Z
L	H	Z	H	Z	Z
H	L	Z	Z	H	Z
H	H	Z	Z	Z	H

Z: High Impedance



Pulse Amp. for VT Voltage

This is an open collector inverter used to amplify the pulse width modulation signal from the tuner microcomputer.

The equivalent circuit is as follows. *T-77-07-05*
 If necessary, a speed up capacitor may be used at the input stage.

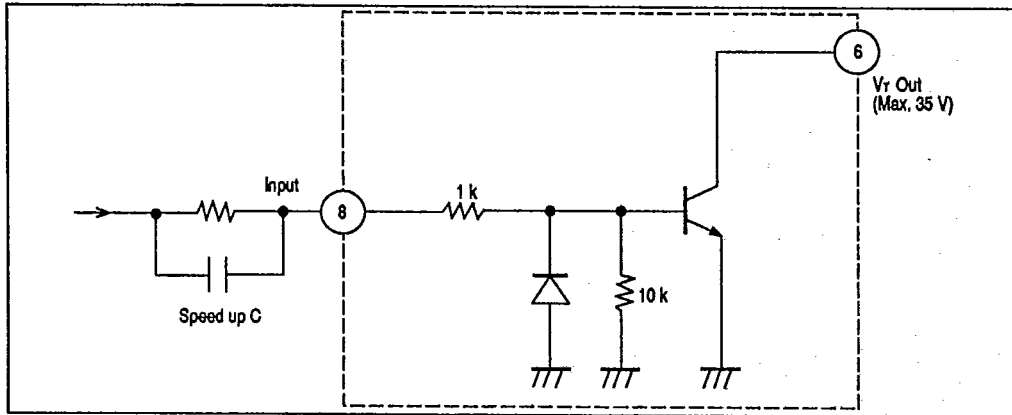

Figure 1 Pulse Amplifier Equivalent Circuit

AFC Switch

- Fixes the AFC signal line to 1/2 Vcc by a control signal from the tuner microcomputer.

- The output impedance is low. The difference of output voltage is less than ± 0.1 V when the output current change is ± 2 mA.
- Stabilized for ambient temperature.
- The block diagram is as follows.

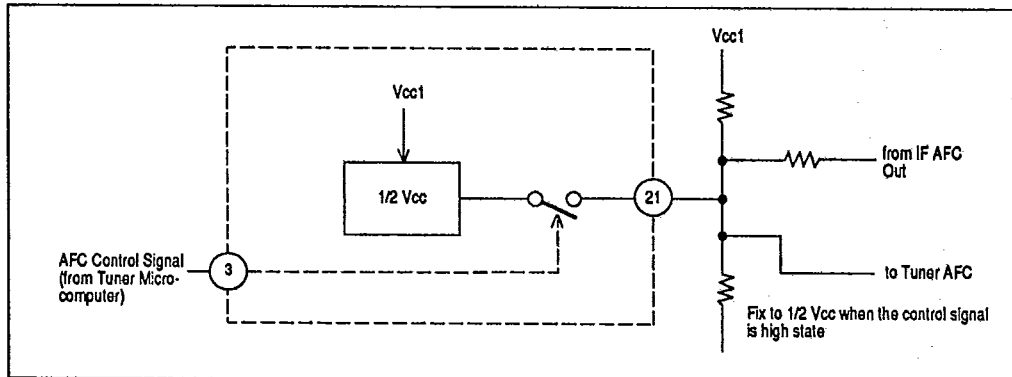

Figure 2 Block Diagram of AFC Switch

Power Supply

+5 V Power Supply (Pin 15)

- +5 V power supply for tuner microcomputer and the peripheral circuits built-in.
- The maximum source current is 25 mA.
- This power supply is used for the AC timer wave shaper, relay controller and remote control pre-amp.

Power Supply Relay Controller

- Drives the power supply relay directly by a control signal from the tuner microcomputer.
- The output NPN transistor is able to sink typ. 40 mA. (max 80 mA)
- Block diagram is as follows.



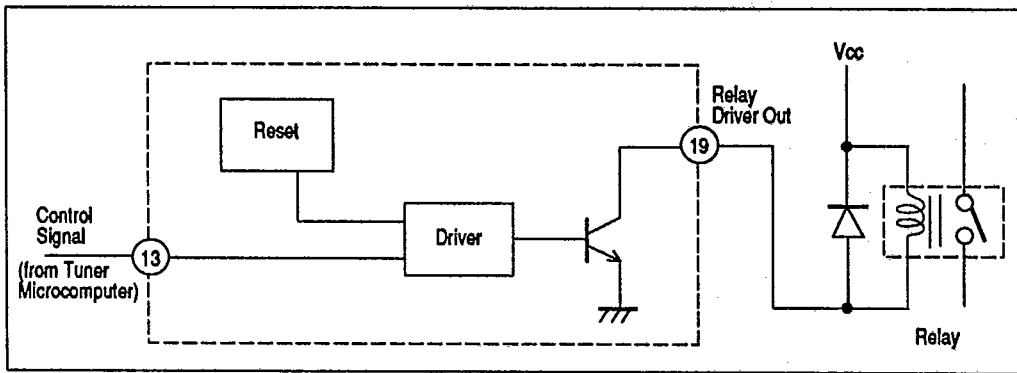

Figure 3 Block Diagram of Power Supply Relay Controller

Reset Circuit for Tuner Microcomputer

The reset pulse for the tuner microcomputer is available when the power supply of the +5 V stabilized power is on. It is possible to adjust the rise time of the reset pulse by using the external capacitor and resistor connected to pin 14. While Vcc2 is less than 6.5 V (typ.) the output level of pin 14 is kept low. With Vcc2 above 6.5 V

the output level of pin 14 rises +5 V (VDD) with the time constant τ_1 determined by the external capacitor C1 and resistor R1.

The positive transition is accelerated by a charge-up current from the IC when the output level is higher than 3.15 V. The output level is maintained above 4.2 V. The block diagram is as follows.

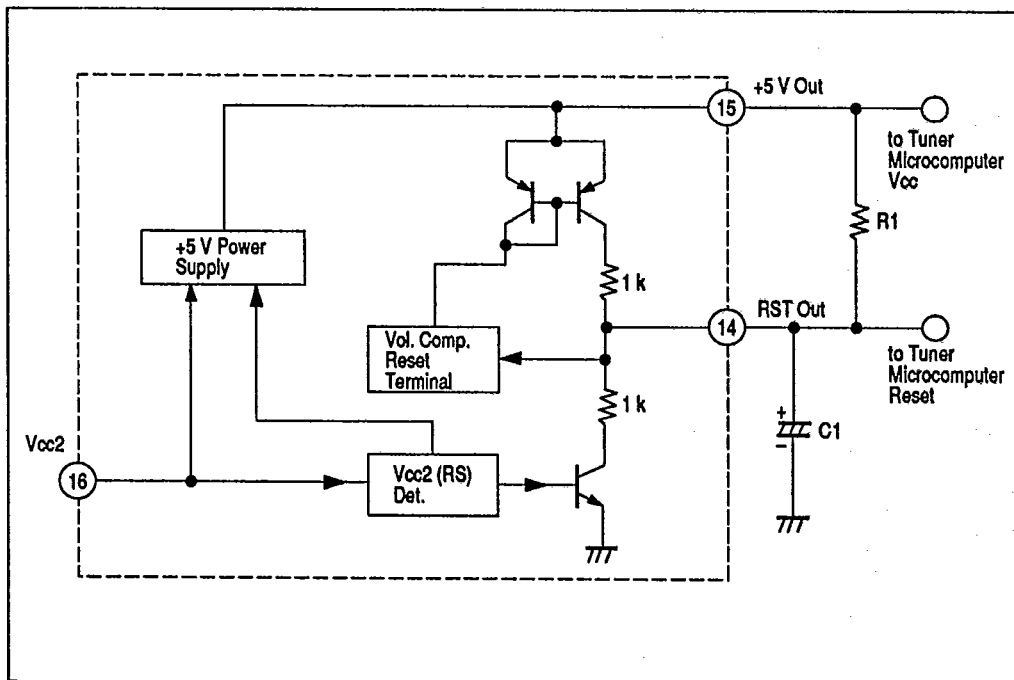

Figure 4 Block Diagram of Reset Circuit



The Tuner Microcomputer Peripheral Circuits

Buffer Amp for Sound Volume Control

This is an inverted amp used to smooth the pulse width modulated signal for sound volume control.

The 5 V - 0 V pulse is converted to a 12 V (9 V) - 0 V signal.

The push pull output makes it easy to select the volume control characteristics. A block diagram and example volume control circuits are shown below.

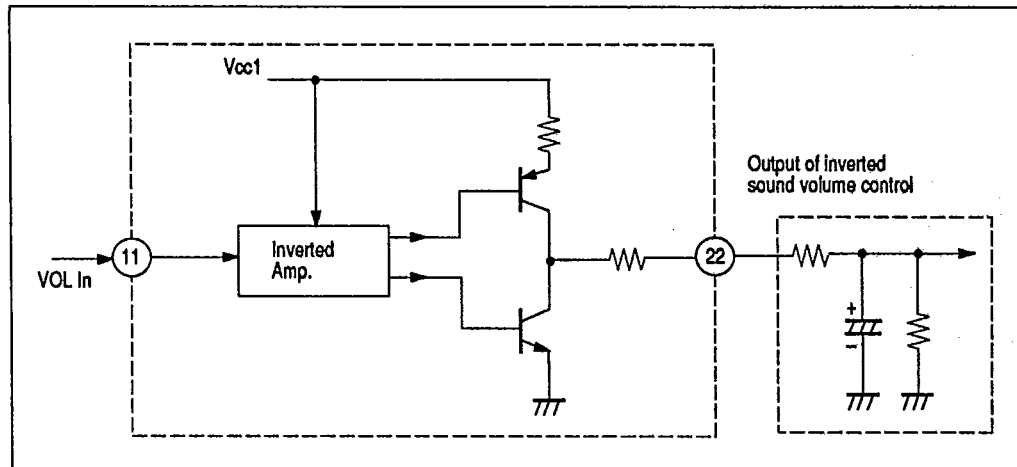

Figure 5 Block Diagram of Volume Control Buffer Amp.

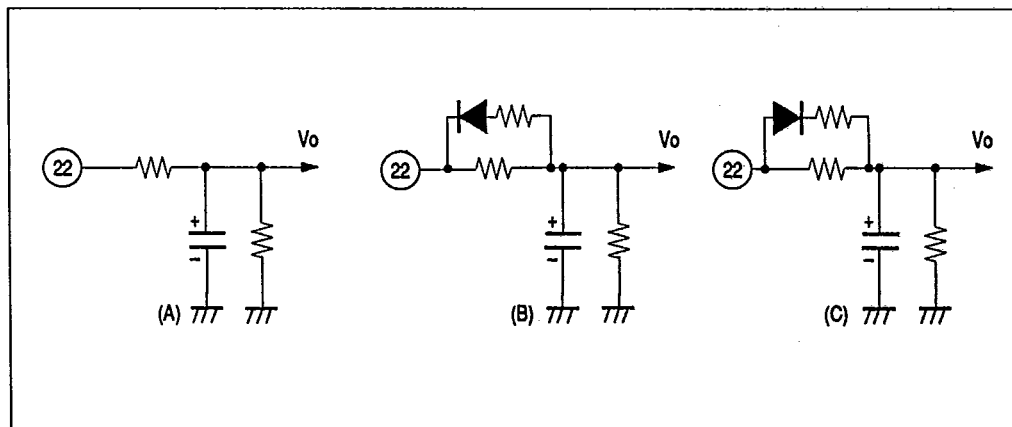

Figure 6 Examples of Sound Volume Control Voltage



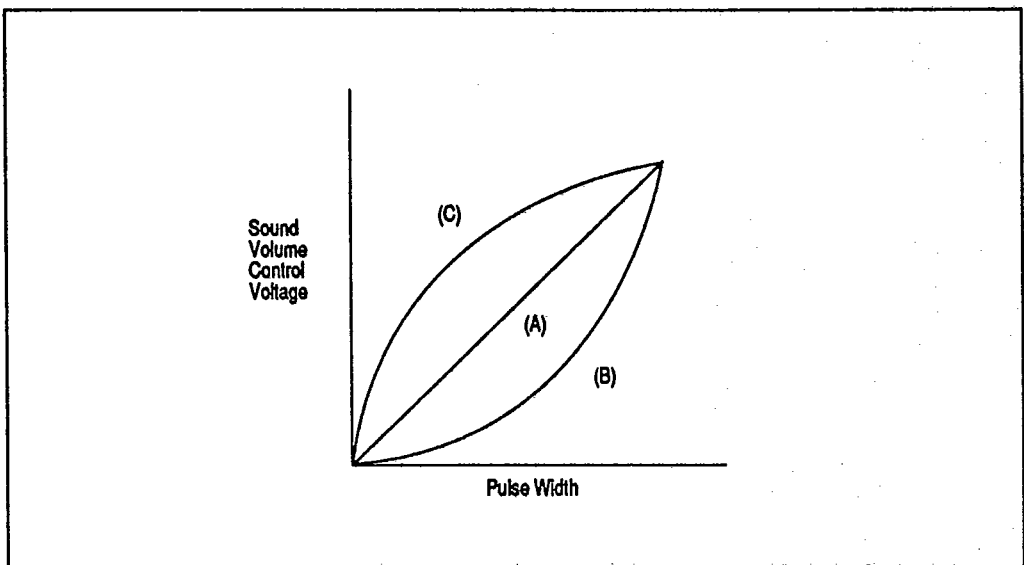

Figure 7 Sound Volume Control Voltage vs. Pulse Width

Waveform Shaper for AC Timer

The AC power supply waveform can be converted to a 5 V – 0 V waveform using the built-in comparator. To improve noise immunity the comparator has built in hysteresis.

The amplitude of the AC waveform may be changed by the status of the power supply relay. In such cases ensure that there is sufficient amplitude to cross the comparator thresholds. The output can be connected directly to the tuner microcomputer because this block uses the 5 V power supply.

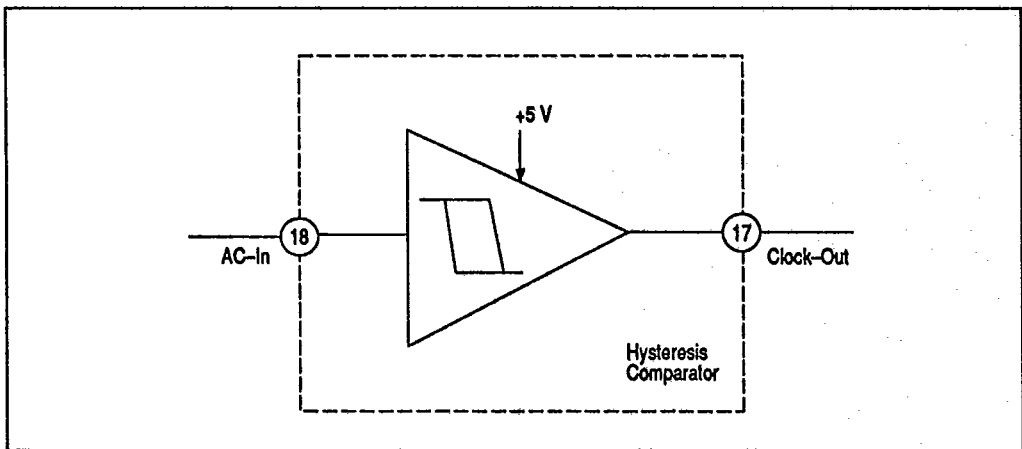

Figure 8 Hysteresis Comparator

