

HA11545A

T-77-09

RF Modulator

Description

The HA11545A is included RF carrier oscillator, video modulation, FM modulator, white clip level adjustment, RF carrier and antenna switch on/off. RF oscillator circuit can allow SAW resonator more loss because we offer RF carrier switch and

antenna driver for TV antenna and VCR function select.

RF output used A/V split for RF output facility make side band cut circuit.

Block Diagram

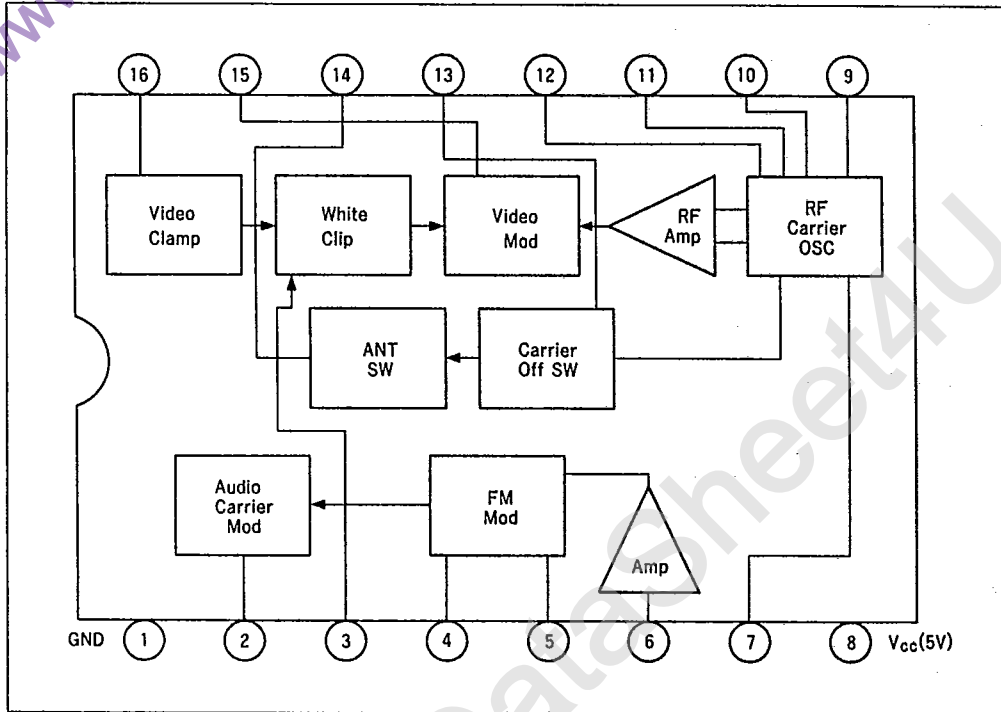

Ordering Information

Type No.	Package
HA11545A	DP-16



www.DataSheet4U.com

HA11545A

T-77-09

Table 1 Functional Description

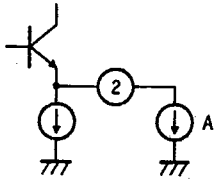
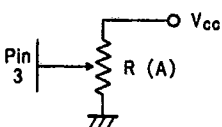
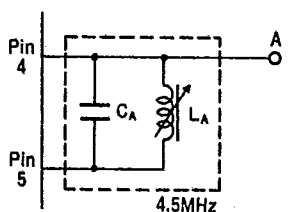
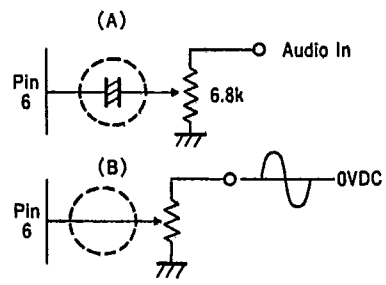
Function	Related Pin No.	Description
Ground	1	Common ground
Audio RF output	2	 <p>Audio RF circuit is emitter follow that output current below 1.5 mA. A ≅ 0 - 1.5 mA</p>
White clip	3	 <p>R ≅ 300 k - 1 MΩ (A) Adjust white clip level at center.</p>
FM mod and OSC circuit	4, 5	 <p>Pin 4 and pin 5 are FM modulation circuit that CA and LA make 4.5 MHz OSC resonator circuit. Pin 4 DC level ≅ DC and pin is mod output.</p>
Audio input	6	 <p>When audio input signal at 1 kHz and input level ±70 mVp-p that the output FM deviation is ±25 kHz. The audio input impedance ≅ 100 kΩ.</p>



HA11545A

T-77-09

Functional Description (cont)

Channel SW 7

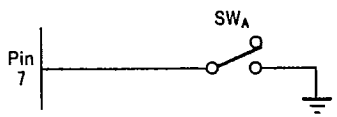

SWA for channel selector.
SWA switched to ground is high CH.
SWA switched to open is low CH.

Supply voltage 8 DC supply voltage allow in 4.5 V_{DC} to 5.5 V_{DC}.

RF carrier oscillator 9, 10, 11

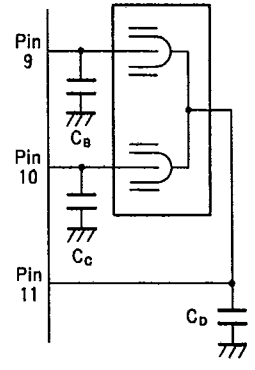

RF carrier oscillator circuit can use any type SAW resonator. C_b and C_c are compensation resonator point (if necessary). C_d is important for RF harmonic rejection and high frequency cut.

Compensation of differential phase 12

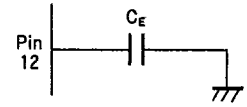

CE used compensation of differential phase in order to suggest the capacitor value ≅ 22 pF.

Carrier off SW 13

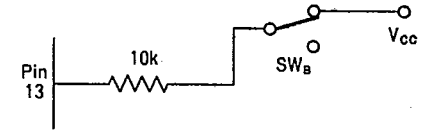

SW_B connect to V_{CC} then RF carrier oscillator on.
SW_B connect to open then RF carrier oscillator off.



HA11545A

T-77-09

Functional Description (cont)

TV antenna 14
SW driver

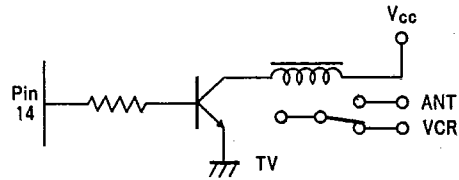

Pin 14 is for ANT and VCR selection. The stream output current max about 30 mA.

Carrier SW and TV driver output relation was shown as below.

RF carrier SW	TV driver output
5 V on	3.4 Vcc
Open Off	0 Vcc

RF video output 15

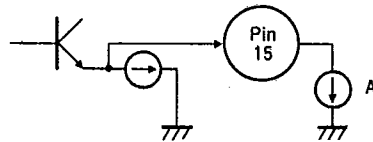

RF video output as same as RF audio output used emitter follow.
A ≅ 0 to 1.5 mA

Video input 16

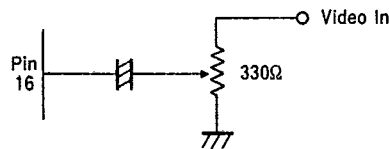

Video input signal level set 0.68 Vp-p then output modulation ≅ 80 %.
The input impedance ≅ 30 kΩ.



HA11545A

T-77-09

Table 2 Absolute Maximum Ratings (Ta = 25 °C)

Item	Symbol	Rating	Unit
Supply voltage	Vcc	6	V
Power dissipation	Pr	600	mW
Operating temperature	Topr	-20 to +70	°C
Storage temperature	Tstg	-55 to +125	°C

Note: Operating Vcc range 4.5 V to 5.5 V.

Table 3 Electrical Characteristics (Ta = 25 °C)

Item	Symbol	Min	Typ	Max	Unit	Test conditions	Test pin
Quiescent current	Icc	10	14	18	mA		8
Video output level	Vo	90.0	93.0	96.0	dBμ	No input	15
Video modulation	Vm	73	80	87	%	Video input = 0.68 Vp-p	15
Video output level differential	ΔVo	-2	0	2	dB	Channel switch ON or OFF	15
Video modulation differential	ΔVm	-3	0	3	%	Channel switch ON or OFF	15
Video S/N	Vsn	50	60	—	dB	VM = 50 %	15
Video bandwidth	Vf	-1.0	0	1.0	dB	fM = 0.5 MHz to 5 MHz	15
White clip level	VW	86.5	90	93.5	%	Pin 3 is open	15
Video output V/S ratio	Vs	2.7	3.0	3.3	—	Input V/S ratio Sync.: Video = 3:10	15
Differential gain	DG	—	2	5	%	CHROME = 20 IRE	15
Differential phase	DP	—	2	5	deg	CHROME = 20 IRE	15
RF carrier ratio of video to audio	AO	5.0	6.5	8.0	dB		2, 15
Audio modulation	AM	20	25	30	±kHz/dev	Audio input = 0.14 Vp-p	2
Audio distortion	ATHD	—	0.3	1.0	%	AM = 60 %	5



HA11545A

T-77-09

Electrical Characteristics (Ta = 25 °C) (cont)

Max audio modulation	AMM	100	175	—	±kHz/dev		2
Audio S/N	ASN	50	60	—	dB	AM = 60 %	5
Audio bandwidth	Af	-1.0	0	1.0	dB	f _M = 1 kHz to 60 kHz	5
Video input impedance	Rv	10	30	—	kΩ		16
Audio input impedance	R _A	75	100	145	kΩ		6
In band spurious	Sin	—	-75	-65	dB	within f _v to f _a	2, 15
920 kHz beat	Cb	—	-68	-57	dB	Input = 0.82 V _{p-p}	2, 15
FA harmonic	nFA	23	28	—	dB	No input	2
ANT SW on output voltage	ASV	3.1	3.4	3.7	V	Load current ≅ 15 mA	14
ANT SW off output voltage	ASRV	0	0	0.1	V		14
Carrier off SW carrier off voltage	COFF	0	—	0.5	V	V _{CC} = 5 V _{CC}	13
Carrier off SW carrier on voltage	CON	2.5	—	5.0	V	V _{CC} = 5 V _{CC}	13



HA11545A

T-77-09

Table 4 Testing Method

Item	Symbol	Input signal	Input terminal	Test method
Quiescent current	I _{CC}	1	BNC(A)	Measure the current at pin 8.
Video output level	V _O	—	—	Connect a spectrum analyzer to terminal A and measure it.
Video modulation	V _M	1	BNC (A)	Measure the output waveform at terminal D with a oscilloscope.

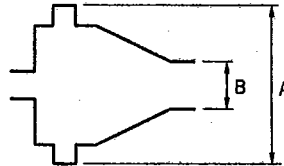

Video output level differential	V _O	1	BNC (A)	Turn SW1 and measure video output level. V = test 3 - test 4
Video modulation	V _M	1	BNC (A)	Turn SW1 and measure video modulation level. V = test 3 - test 4
Video S/N	V _{SN}	5	BNC (A)	Adjust input signal level so that video modulation is 50 %. Connect a video detector and noise meter at terminal D and measure it.

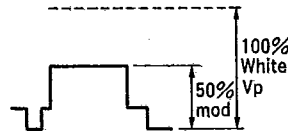

Video band width	V _f	4	BNC (A)	Measure the video output level at terminal A with spectrum analyzer.
------------------	----------------	---	---------	--

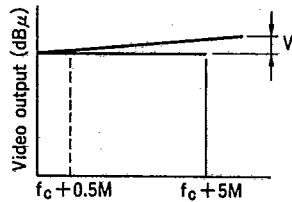

HA11545A

T-77-09

Testing Method (cont)

White clip level VW 3 BNC (A) Measure the output waveform at terminal D with a oscilloscope.

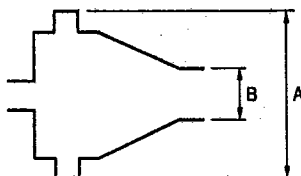

Video output V/S V/S 1 BNC (A) Measure the output waveform at terminal D with a oscilloscope.

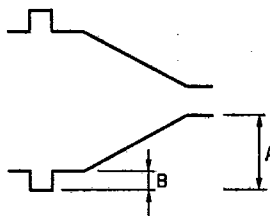

Differential gain	DG	8	BNC (A)	Adjust input signal so that output video modulation level is 80 %.
Differential phase	DP	8	BNC (A)	Connect a vectorscope and video detector to terminal D and measure it.
RF audio output	AO	—	—	Connect A spectrum analyzer to B and measure it.
Audio modulation	AM	6	BNC (B)	Measure the output level at terminal B with spectrum analyzer.
Audio THD	ATHD	6	BNC (B)	Adjust audio input signal level so that output audio THD is 5 % and measure modulation level at terminal B with spectrum analyzer.
Max audio	AM	6	BNC (B)	Adjust input signal level so that output audio THD is 5 % and measure modulation level at terminal B with spectrum analyzer.
Audio S/N	AS/N	6	BNC (B)	(A) Adjust input signal level at audio so that modulation level is 16 kHz/dev. Measure FM detector output level at terminal C with audio analyzer. (A) $S/N = 20 \log$ (B)



HA11545A

T-77-09

Testing Method (cont)

Audio bandwidth Af 7 BNC (B) Measure the output level at C with FM detector and audio analyzer.

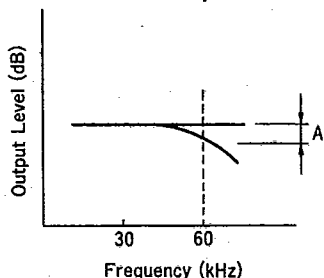

Video input impedance Rv 1 BNC (C) Apply input signal to terminal C and measure cycle signal level at pin 16, A.

$$\frac{A}{\text{Input signal synchronous level}} = C$$

$$\text{Input impedance} = \frac{10 k \times C}{(1 - C)}$$

Audio Input Impedance RA — — Measure voltages at pin 6 when SW3 is ON and OFF.

$$\frac{\text{Voltage at pin 6 when SW3 is ON}}{\text{Voltage at pin 6 when SW 3 is OFF}} = A$$

$$\frac{100 \times (1 - A)}{A}$$

In-band spurious Sin — — Measure spurious between FV and FA, and measure FV – spurious level.

920 kHz beat Cb 9 BNC (A) (A) Measure $f_p + 920$ kHz component at terminal D by spectrum analyzer.
(B) Measure f_p level without signal.
 $A - B$

FA harmonic nFA — — Measure audio carrier ($f_c + 4.5$ MHz) component and its harmonic at terminal B.

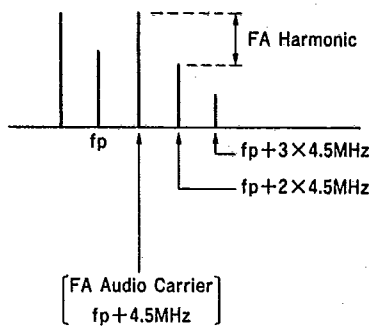

HA11545A

T-77-09

Input Signal Waveforms

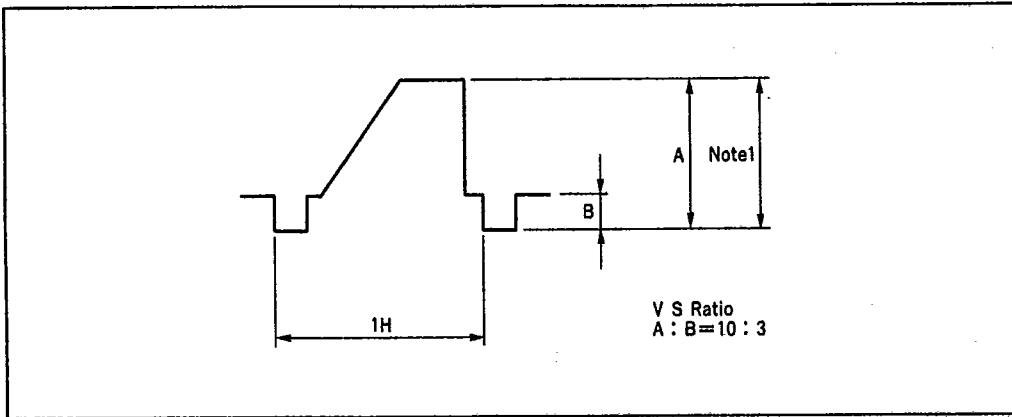

Video Signal-1

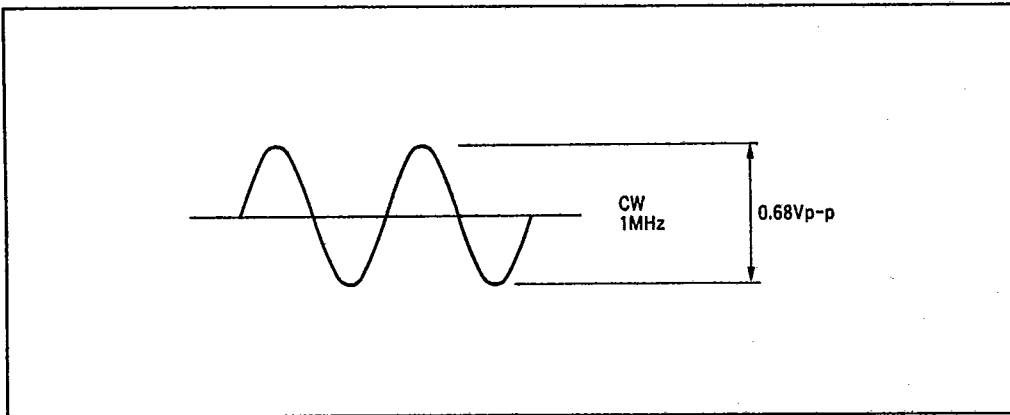

Sine Wave Signal-1

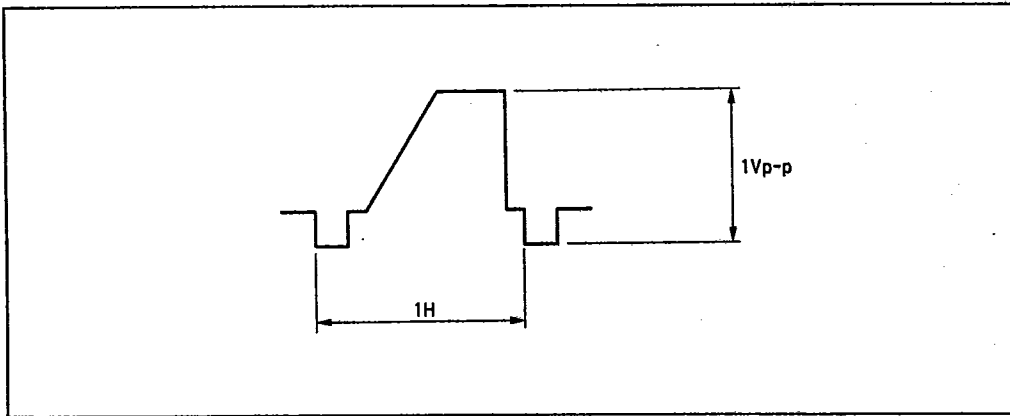

Video Signal-2



HA11545A

T-77-09

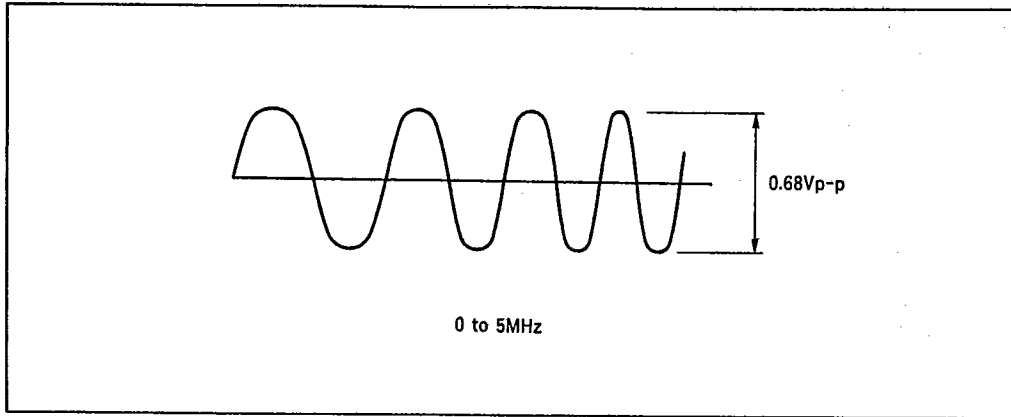

Sweep Signal-1

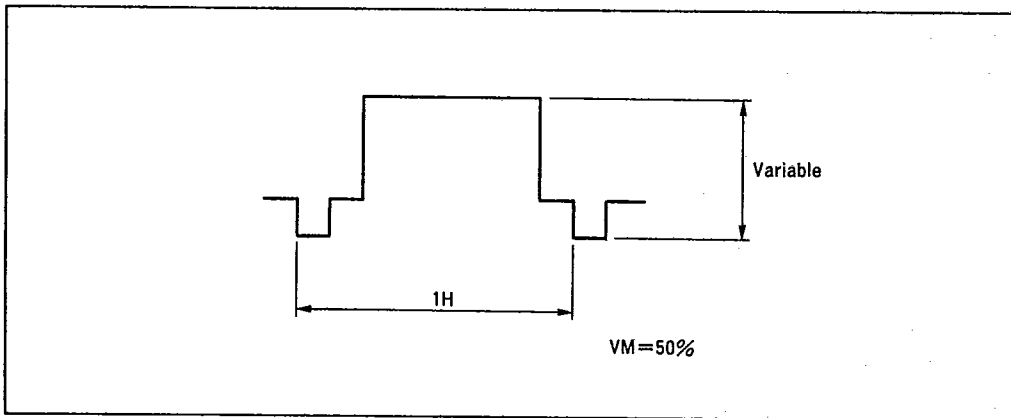

Video Signal-3

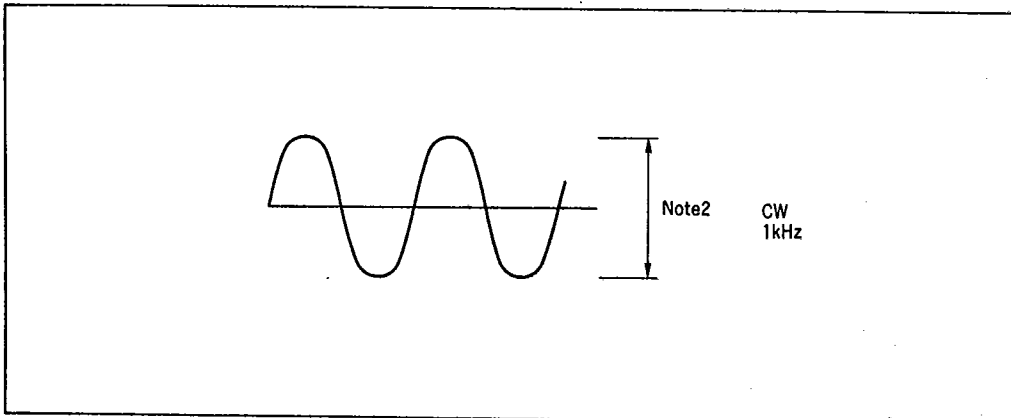

Sine Wave Signal-2



HA11545A

T-77-09

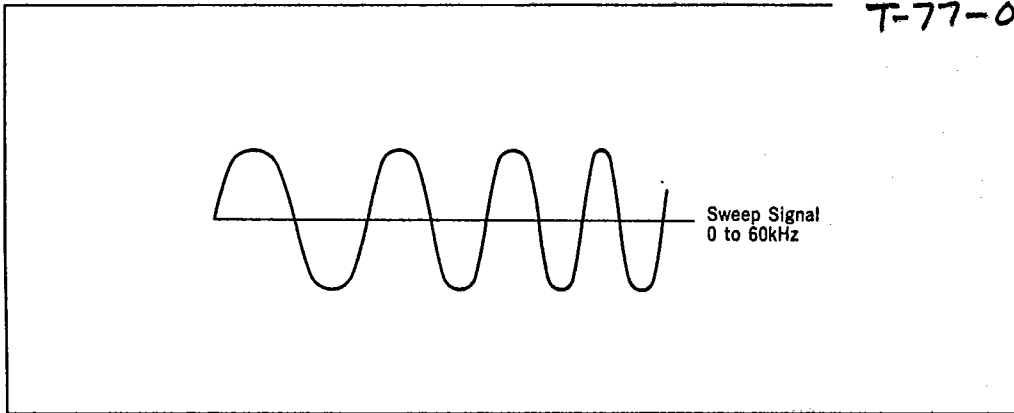

Sweep Signal-2

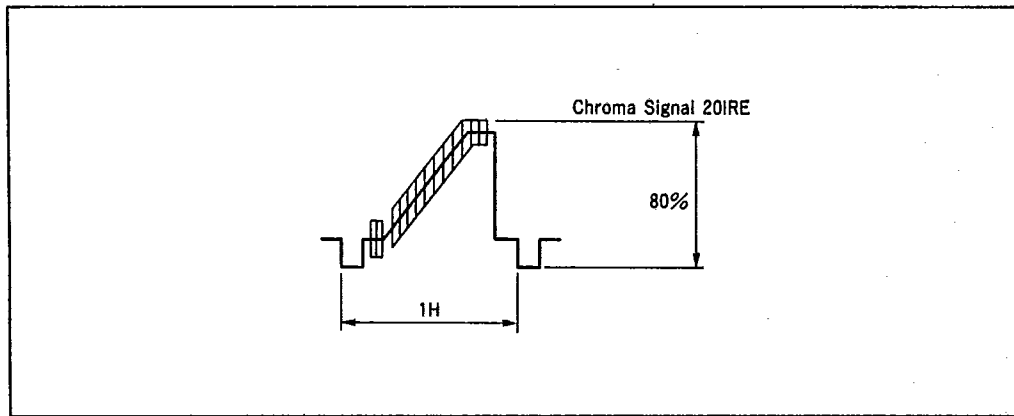

Video Signal-4

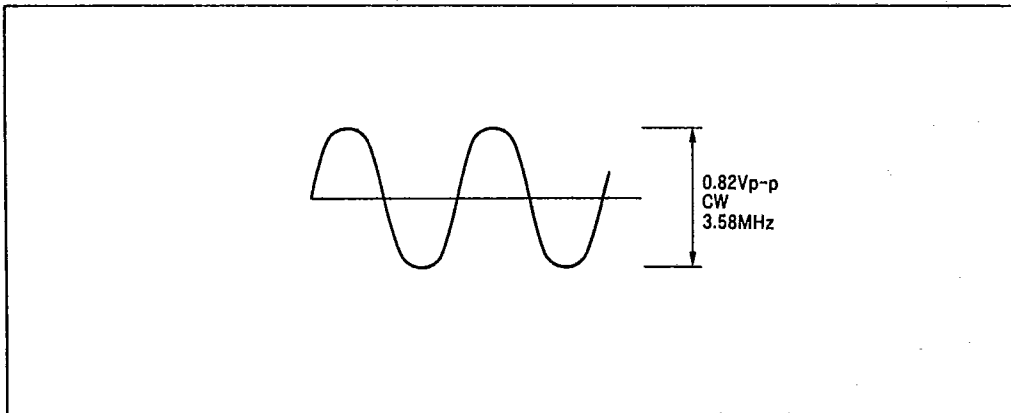

Sine Wave Signal



HA11545A

T-77-09

Application Circuit

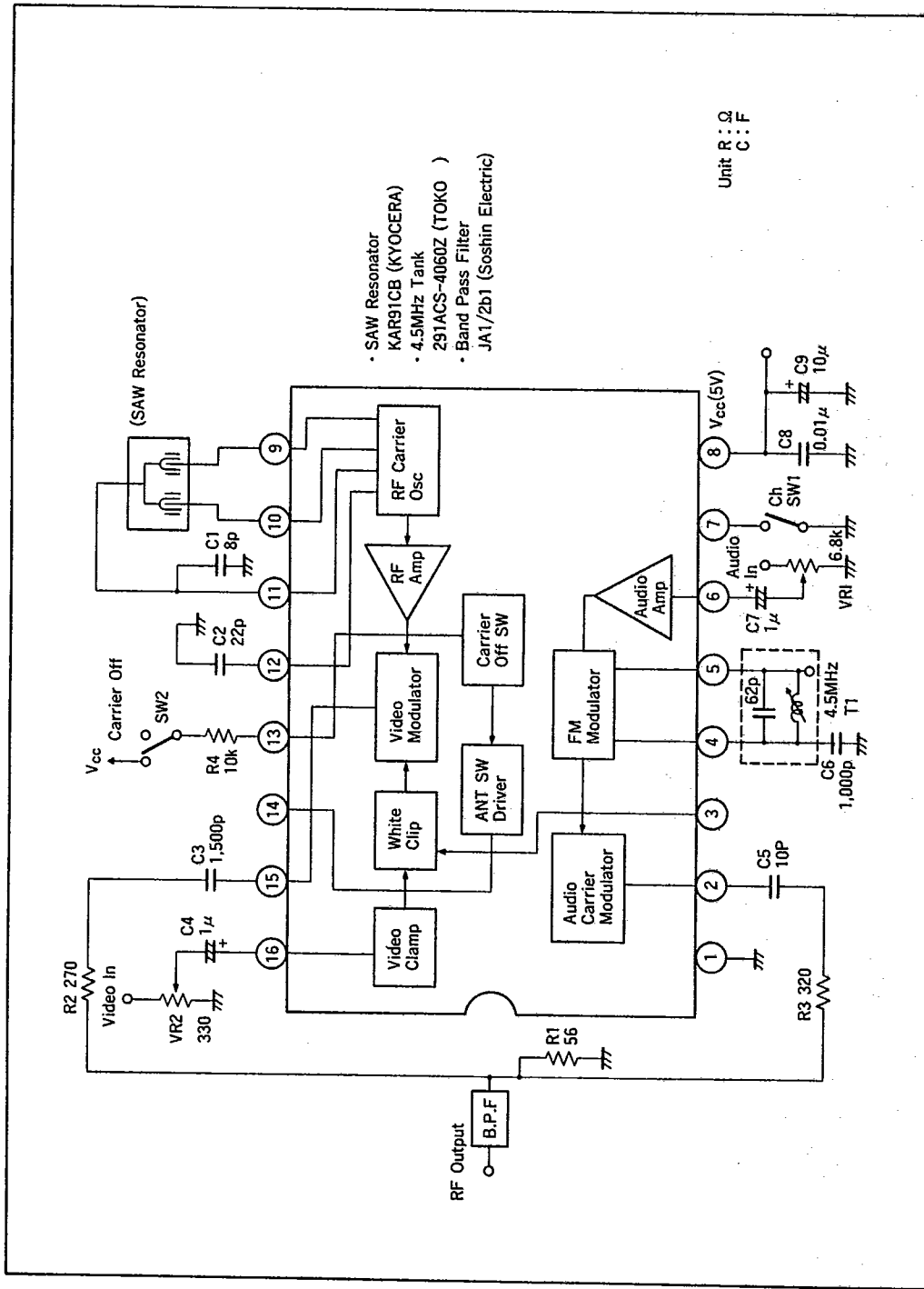

HA11545A

Application Board Pattern

T-77-09

Copper Side Pattern

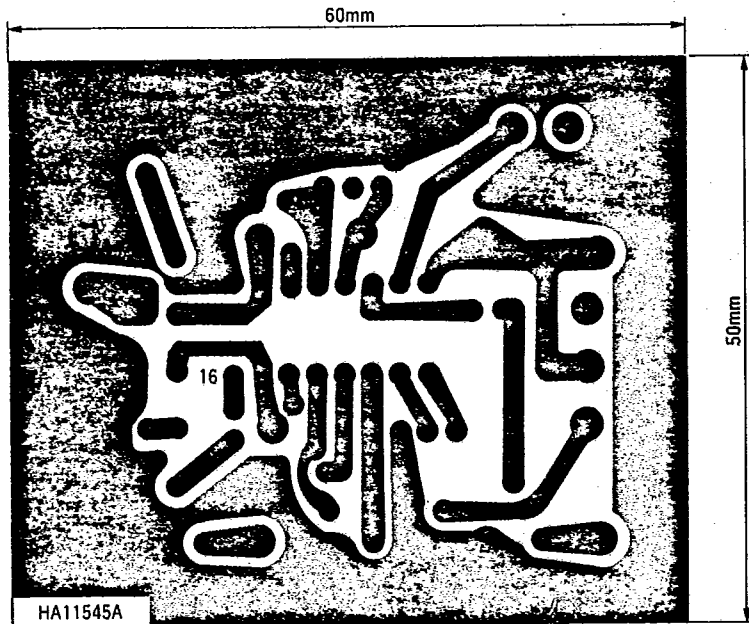

Component Side

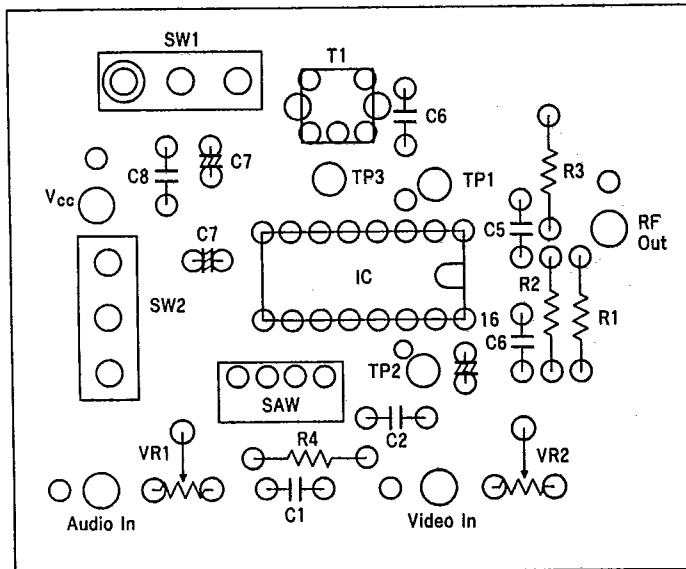

HA11545A

T-77-09

Parts List

R1 56 1/4 W 5 %
R4 10 k 1/4 W 5 %

R2 270 1/4 W 5 %
VR1 6.8 k

R3 820 1/4 W 5 %
VR2 330

C1 8 p NPO 25 Vdc
C4 1 μ F 25 Vdc
C7 1 μ F 25 Vdc

C2 22 p NPO 25 Vdc
C5 10 p NPO 25 Vdc
C8 0.01 μ F 25 Vdc

C3 1500 p 25 Vdc
C6 1000 p 25 Vdc
C9 10 μ F 25 Vdc

T1 4.5 MHz Tank 291 ACS-4060Z (Toko)
SAW Resonator KAR91CB (Kyocera)

