

HA118082MA

T-77-17

4-channel Processor for Video Cameras

Features

- New feedback clamp system reduces components and adjustments
- Low supply current ($V_{CC} = 5.0$, 44 mA typ)
- Outstanding frequency characteristics for luminance signal processing circuitry (15MHz typ)
- Perfect for MOS, CCD color cameras

Functions

- Feedback clamp
- White balance gain control
- Previous level/following level AGC
- γ -correction
- BLK, white clip, black clip
- YL matrix
- Color difference amplifier
- Fade
- Low-illumination 3.58MHz trap
- Red brightness correction
- Low-illumination green correction
- High-band mixing, sync adder

Absolute Maximum Ratings ($T_a = 25^\circ\text{C}$)

Item	Symbol	Rating	Unit
Supply Voltage*1	V_{CC}	7	V
Power Dissipation*2	P_T	430	mW
Operating Temperature	T_{opr}	-10 to +75	$^\circ\text{C}$
Storage Temperature	T_{stg}	-55 to +125	$^\circ\text{C}$

Notes:

*1 Operating supply voltage: 4.9 to 5.25V

*2 Rated value at $T_a = 25^\circ\text{C}$ under the following conditions:

Basic material: Glass epoxy 40mm \times 40mm \times 15mm

Wiring density: 30%

Ordering Information

Type No.	Package
HA118082MA	MP-44S



HA118082MA

T-77-17

Block Diagram

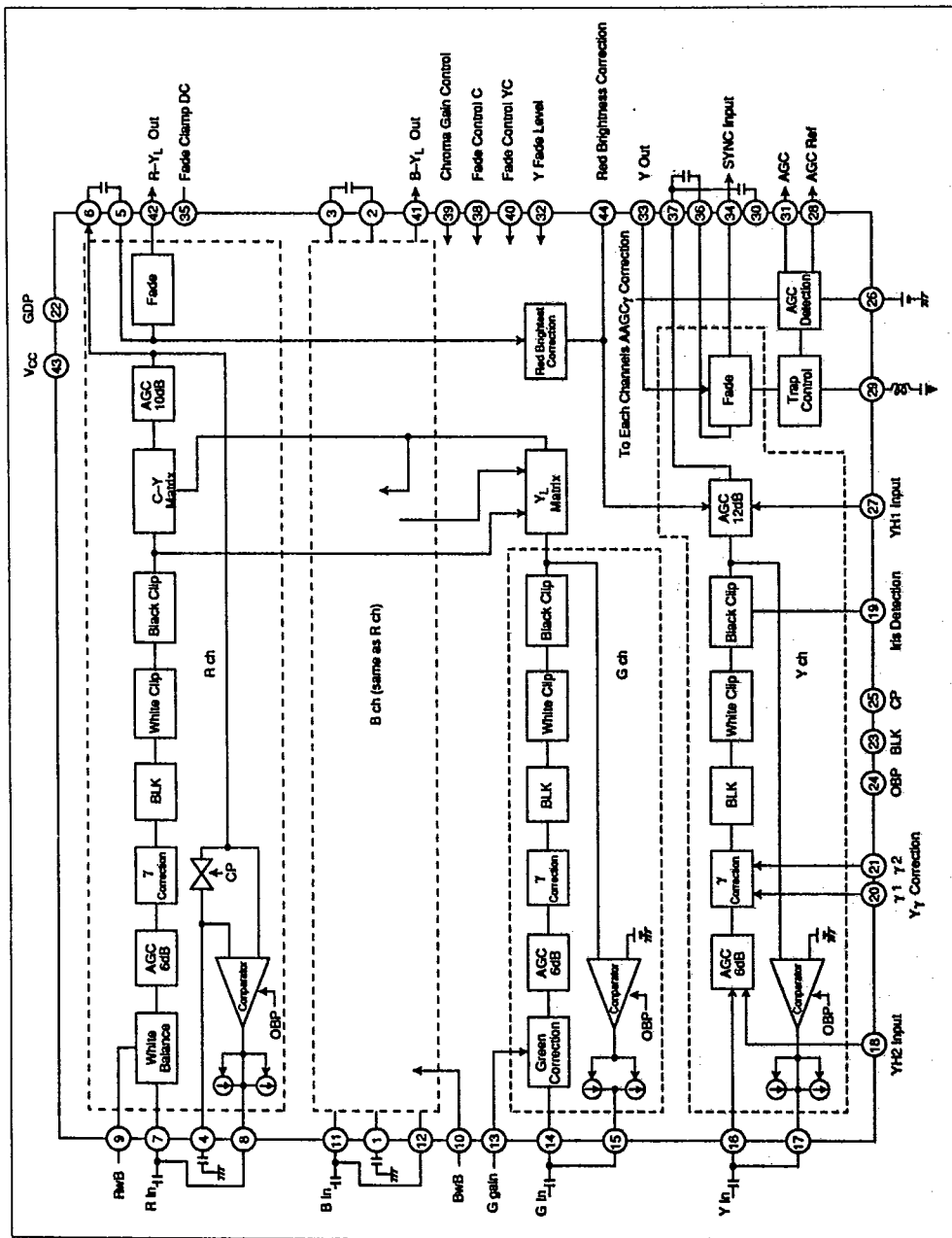

HA118082MA

T-77-17

Pin Functions

Pin No.	Function	Ref. DC Voltage (V)	Signal Type	Signal Level	I/O Impedance (Ω)
1	Bch Black Level Hold	2.6	DC	—	Base input S/H switch
2	Bch Fade Input	2.9	B-Y _L	0.4Vp-p	Base input clamp switch
3	B-YL Process Output	2.6	B-Y _L	0.4Vp-p	Emitter-follower
4	Rch Black Level Hold	2.6	DC	—	Base input S/H switch
5	Rch Fade Input	2.9	R-Y _L	0.4Vp-p	Base input clamp switch
6	R-YL Process Output	2.6	R-Y _L	0.4Vp-p	Emitter-follower
7	Rch Process Input	2.7	R	0.2Vp-p	Base output
8	Rch Feedback Comparator Output	2.7	—	—	Collector output
9	Rch White Balance Control	3.0	—	—	3k
10	Bch White Balance Control	3.0	—	—	3k
11	Bch Process Input	2.7	B	0.2Vp-p	Base input
12	Bch Feedback Comparator Output	2.7	—	—	Collector output
13	Gch Gain Control	3.0	—	—	3k
14	Gch Process Input	2.7	G	0.22Vp-p	Base input
15	Gch Feedback Comparator Output	2.7	—	—	Collector output
16	Ych Process Input	2.7	Y	0.18Vp-p	Base input
17	Ych Feedback Comparator Output	2.7	—	—	Collector output
18	High Band Mixing Input 2	1.3	—	—	2k
19	Iris Detection Output	2.0	—	—	Emitter output
20	Yg Correction Curve Point 1	1.5	—	—	Base input
21	Yg Correction Curve Point 2	1.7	—	—	Base input
22	GND				
23	BLK Input	—	BL	5Vp-p	Base input, emitter output
24	OBP Input	—	OBP	5Vp-p	Base input
25	CP Input	—	CP	5Vp-p	Base input
26	AGC Filter	—	DC	—	
27	High Band Mixing Input 1	1.1	—	—	5k
28	AGC Reference Voltage	3.6	—	—	Emitter-follower
29	Trap Control Output	Trap ON	0	—	See Figure 9
		Trap OFF	3.9		
30	AGC Detection Output	3.0	Y	0.83Vp-p	20k
31	AGC Data Output	AGC min	3.0	—	Emitter-follower
		AGC max	4.2		
32	Y Fade Level Control	2.6	DC	—	13.5k



HA118082MA

T-77-17

Pin No.	Function	Ref. DC Voltage (V)	Signal Type	Signal Level	I/O Impedance (W)
33	SYNC Input	1.5	SYNC		8k
34	Ych Fade Output	2.1	Y	0.81Vp-p	E.F
35	Fade Clamp DC Filter ^{2.9}	—	—	Clamp switch	
36	Ych Fade Input	2.9	Y	0.83Vp-p	Base input clamp switch
37	Ych Process Output	1.85	Y	0.83Vp-p	E.F
38	Cch Fade Control	—	DC	—	Base input
39	Cch Gain Control	—	DC	—	Base input
40	Ych, Cch Fade Control	—	DC	—	Base input
41	B-Y _L Fade Output	2.1	B-Y _L	1.34Vp-p	E.F
42	R-Y _L Fade Output	2.1	R-Y _L	1.06Vp-p	E.F
43	V _{CC}				
44	Red Brightness Correction Control	2.9	DC	—	See Figure 10



HA118082MA

Electrical Characteristics ($V_{CC} = 5V, T_a = 25^\circ C$)

T-77-17

Item	Symbol	Min	Typ	Max	Unit	Test Condition	Applicable Terminal	Notes
Supply Current	I_{CC}	31	44	61	mA	43 supply current	43	
Y Rated Input	e_{Yin}	—	180	—	mVpp		16	
R Rated Input	e_{Rin}	—	200	—	mVpp		7	
B Rated Input	e_{Bin}	—	200	—	mVpp		11	
G Rated Input	e_{Gin}	—	220	—	mVpp		14	
Y Rated Output	e_{Yo}	—	830	—	mVpp		37	
R-YL Rated Output	e_{Ro}	—	1060	—	mVpp		6	
B-YL Rated Output	e_{Bo}	—	1340	—	mVpp		3	
Y Output DC Voltage	E_Y	1.35	1.85	2.35	V		37	
R-YL Output DC Voltage	E_R	2.1	2.6	3.1	V		6	
B-YL Output DC Voltage	E_B	1.8	2.3	2.8	V		3	
Ych Gain	G_{Y1}	9.8	11.8	13	dB	$s_i = 10mVpp, f = 200kHz$ $v_i = 25mVpp$	16, 37	See note 1
Rch I/O Characteristics	R_{25}	15	40	60	mVpp	$v_i = 25mVpp$	7, 6	
idem	R_{150}	125	175	215	mVpp	$v_i = 150mVpp$	7, 6	
idem	R_{250}	180	230	270	mVpp	$v_i = 250mVpp$	7, 6	
Bch I/O Characteristics	B_{25}	30	55	75	mVpp	$v_i = 25mVpp$	11, 3	
idem	B_{150}	190	240	280	mVpp	$v_i = 150mVpp$	11, 3	
idem	B_{250}	270	320	360	mVpp	$v_i = 250mVpp$	11, 3	

Note 1:

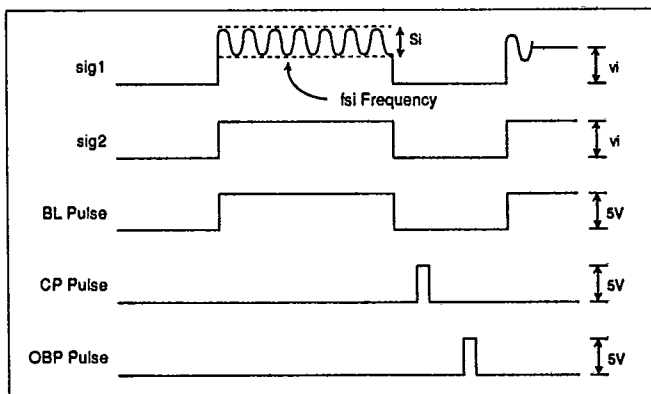

HA118082MA

T-77-17

Item	Symbol	Min	Typ	Max	Unit	Test Condition	Applicable Notes Terminal
Rch WB Adjustable Range	WBR	—	13	—	dB	$v_i = 25mV_{pp}$ $WBR = 20 \log \frac{V_{out}}{R25}$	7, 6
Bch WB Adjustable Range	WBB	—	13	—	dB	$v_i = 25mV_{pp}$ $WBB = 20 \log \frac{V_{out}}{B25}$	11, 3
Gch Correction Range	WBG	—	2	—	dB	Pin 9 $v_i = 25mV_{pp}$ (0V → 5V) $WBG = 20 \log \frac{V_{out}(5V)}{V_{out} + (5V)}$	14, 6
$\gamma_{0.5}$ Slope Ratio	$\gamma_{0.5}$	0.49	0.54	0.61	2X	$\gamma = 1$ as reference	16, 37
γ_{β} Slope Ratio	γ_{β}	2.6	3.0	3.3		$\gamma = 1$ as reference	16, 37
Rch DW	ΔWR	—	—	30	mV	$v_i = 1V_{pp}$ at pins 7, 11, 14 $\Delta Wg = V_{out}$ (pin 6)	7, 11 14, 6
Bch DW	ΔWB	—	—	30	mV	$v_i = 1V_{pp}$ at pins 7, 11, 14 $\Delta WB = V_{out}$ (pin 3)	7, 11 14, 3
BLK OFF Level	E_{BLOF}	4	—	—	V		23
BLK ON Level	E_{BLON}	—	—	0.2	V		23
CP OFF Level	E_{CPOF}	—	—	1	V		25
CP ON Level	E_{CPON}	4	—	—	V		25
OBP OFF Level	E_{OBOF}	—	—	0.2	V		24
OBP ON Level	E_{OBON}	4	—	—	V		24
White Clip Level	W_C	950	1000	1050	mV	$16V_{\gamma} v_i = 1V_{pp}$ $W_C = v_i$ (pin 37)	16, 37
AGC Black Slice Level	E_{AGCB}	-310	-260	-210	mV	Pin 30 voltage (release voltage at pin 30) when voltage raised at pin 26 on black side	30, 26
AGC White Slice Level	E_{AGCW}	500	560	620	mV	Pin 30 voltage (release voltage at pin 30) when voltage raised at pin 26 on white side	30, 26
Red Brightness Correction Threshold	ΔV_{Rth}	54	70	86	mV	See Figure 10	44, 37
Ych Previous Level AGC	G_{YAGCP}	4.5	6.0	7.5	dB	Pin 26 2V ↔ 4V → ΔG $G_{YAGCP} = \Delta G - G_{YAGC}$	16, 37
Rch Previous AGC	G_{RAGCP}	—	5.5	—	dB	Pin 26 2V ↔ 4V → ΔG $G_{RAGCP} = \Delta G - G_{RAGC}$	7, 6
Bch Previous AGC	G_{BAGCP}	—	5.5	—	dB	Pin 26 2V ↔ 4V → ΔG $G_{BAGCP} = \Delta G - G_{BAGC}$	11, 3
Gch AGC	G_{GAGC}	—	9.5	—	dB	Pin 26 2V ↔ 4V → ΔG $G_{GAGC} = \Delta G$	14, 6
Ych Following Level AGC	G_{YAGC}	10	12	14	dB	Pin 28 GND $G_{YAGC} = \Delta G$ Pin 26 2V ↔ 4V → ΔG	16, 37



HA118082MA

T-77-17

Item	Symbol	Min	Typ	Max	Unit	Test Condition	Applicable Terminal	Notes
Rch Following Level AGC	G _{RAGC}	—	5.5	—	dB	Pin 28 GND G _{RAGC} = ΔG Pin 26 2V ↔ 4V → ΔG	7, 6	
Bch Following Level AGC	G _{BAGC}	—	5.5	—	dB	Pin 28 GND G _{BAGC} = ΔG Pin 26 2V Δ 4V → ΔG	11, 3	
YMX-R Coefficient	M _{XR}	—	0.3	—	2X	MXR = 0.3	7, 6	
YMX-B Coefficient	M _{XB}	0.095	0.105	0.115	2X	MXR = 0.3	11, 6	
YMX-G Coefficient	M _{XG}	0.55	0.59	0.62	2X	MXR = 0.3	14, 6	
Ych Frequency Characteristics	f _{Y1}	10	—	—	MHz	γ = 1	16, 37	
Rch Frequency Characteristics	f _{R3}	3	—	—	MHz	γ = 2	7, 6	
Bch Frequency Characteristics	f _{B3}	3	—	—	MHz	γ = 3	11, 3	
Ych Fade Gain	G _{YF}	-1.7	-0.2	0.5	dB	Input sine wave 0.5Vpp; f = 200kHz	36, 34	
Rch Fade Gain	G _{RF}	2.3	3.8	4.5	dB	Input sine wave 0.5Vpp; f = 200kHz	5, 42	
Bch Fade Gain	G _{BF}	2.3	3.8	4.5	dB	Input sine wave 0.5Vpp; f = 200kHz	2, 41	
Ych Fade Remainder	G _{YFR}	—	—	-35	dB	Input sine wave 0.5Vpp; f = 5MHz; Pin 40 0V ↔ 5V	36, 34, 40	
Rch Fade Remainder	G _{RFR}	—	—	-40	dB	Input sine wave 0.5Vpp; f = 1MHz; Pin 40 0V ↔ 5V	5, 42, 40	
Bch Fade Remainder	G _{RFB}	—	—	-40	dB	Input sine wave 0.5Vpp; f = 1MHz; Pin 40 0V ↔ 5V	2, 41, 40	
Ych Fade f Characteristics	f _{YF}	15	—	—	MHz		36, 34	
Rch Fade f Characteristics	f _{RF}	10	—	—	MHz		5, 42	
Bch Fade f Characteristics	f _{BF}	10	—	—	MHz		2, 41	



HA118082MA

T-77-17

Functional Description

Feedback Clamp Circuit

• Chroma system

YLch feedback clamping is performed by comparing the internal fixed VREF and signal OBP space levels. At this time, the BL pulse is formed on chip as shown at A, and OBP spacing does not apply BL. The black clip level is formed as shown at B in order to expand the FBC adj range and for BL/SIG level difference correction.

The color difference output FBC for E operates to equalize the CP period black level and OBP period signal level. When relative differences exist between the OBP period black level and signal black level at this time, the OBP pulse is superimposed on F input and adjustment is performed. When the sensor OB and signal period black levels are the same, no adjustment of the color difference black level is required.

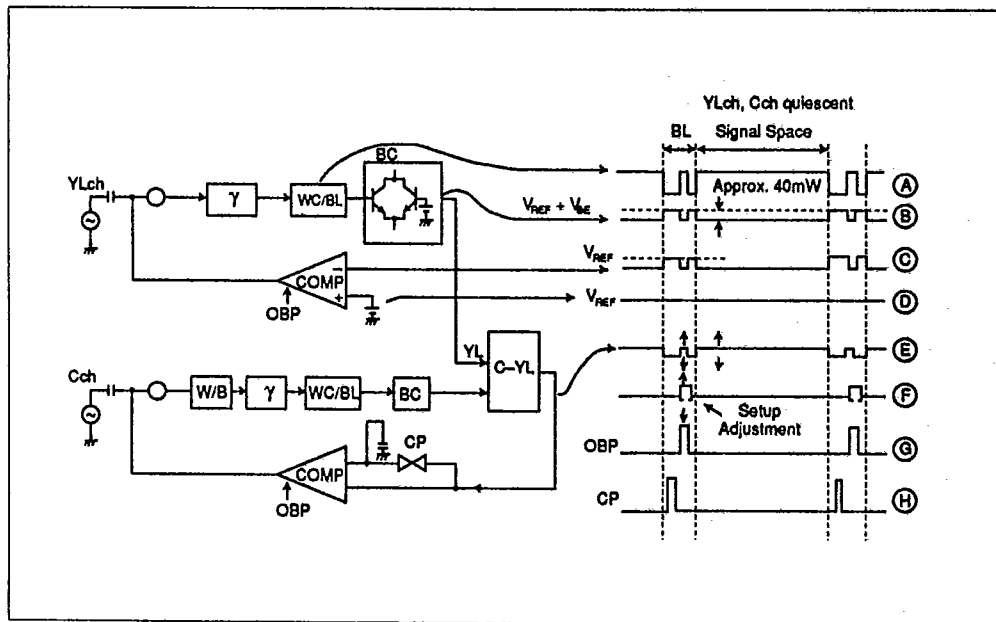

Figure 1.



T-77-17

HA118082MA

Ych feedback clamping is performed the same as that for YLch. Setup adjustment superimposes an OBP pulse on C input, and B level input is adjusted as shown by the dashed lines. (Figure. 2)

γ Correction Circuit

γ correction is performed using 3-segment linear approximation, and γ lines are fixed on chip for both Ych and color ch. Fine tuning of Ych at Pins 20 and 21 is allowed to ensure wide availability to γ characteristics.

HA118082MA features both pre- and post-AGC for the γ correction circuit. Under low illumination when AGC gain is extended, the γ correction circuit input level drops, so the γ point is controlled for reduced γ correction effect.

Figure 3 illustrates an actual example of alteration of the γ correction curve by the AGC. At maximum AGC, there is little change in the correction curve.

HA118082MA adopts a system that performs R, B, G γ correction. When γ correction processes R, B, YL signals, color differences are theoretically generated, with a general tendency towards emphasis on green. Processing R, B, G signals, on the other hand, theoretically eliminates the color difference for improved color reproduction.

Following γ correction, conversion from R, B, G signal to YL signal is performed using Formula (1):

$$YL = 0.3R + 0.59G + 0.11B \dots\dots\dots \text{Formula (1)}$$

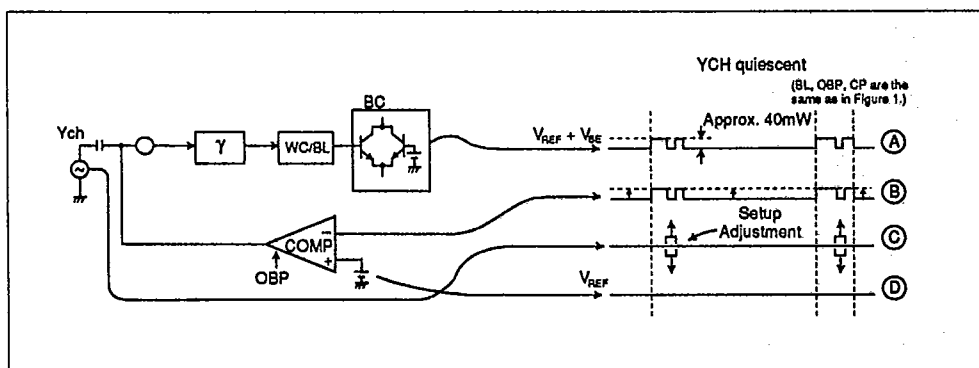

Figure 2.

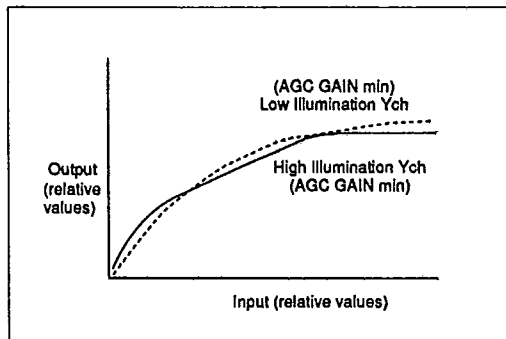

Figure 3. γ Correction Curve



HA118082MA

T-77-17

AGC Circuit

HA118082MA was designed as a low illumination gain amplifier. The variable range for the gain is 16kB (Typ) for the color difference channel and 19dB (Typ) for Ych. To achieve a maximum variable range of 19dB, HA11808MA includes both pre- and post-AGC for the γ correction circuit. Figure 5 illustrates the continuity between the pre- and post-AGC.

Normally, the post-AGC operation is performed after the pre-AGC operation, but application of set voltage at Pins 28 and 31 causes the pre-AGC operation to be performed

following the post-AGC operation, while grounding Pin 28 eliminates the pre-AGC function.

White Balance Circuit

The white balance circuit adjusts the Rch and Bch gain ratio. Figure 4 illustrates gain characteristics. Separate control terminals are provided for Rch (Pin 9) and Bch (Pin 10), and the control characteristics for Rch and Bch are mutually inverse. Because of this, one control data can simultaneously control both channels.

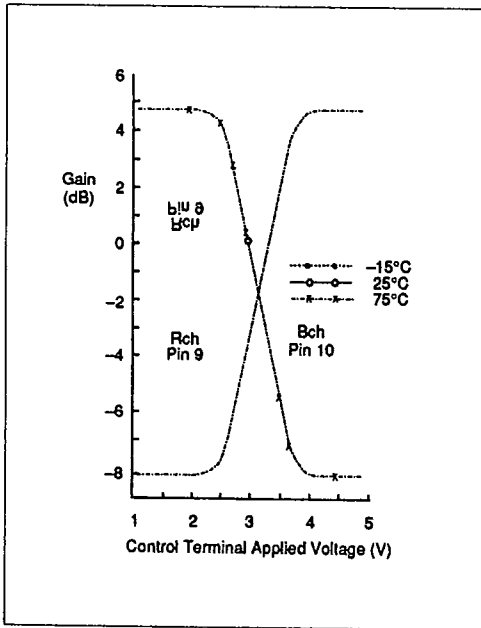

Figure 4. WB Gain Control Characteristics

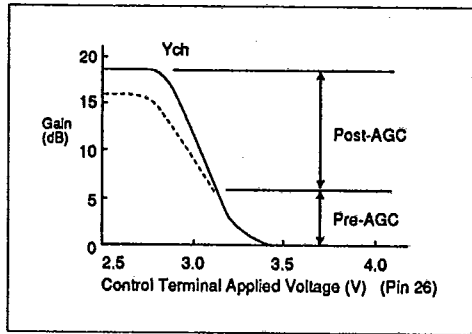

Figure 5. AGC Control Characteristic



HA118082MA

White Clip Control Circuit

During normal input, the white clip control circuit clips peaks above a value stipulated by clip level 120% (typ). Under low illumination, the AGC gain is raised, so the clip level is lowered accordingly to protect against the prescribed peak level from being exceeded.

example, changes the aperture in accordance with luminance. Another application would be input of a correction signal at pin 27 of the post-AGC to eliminated the black level difference that occurs between AGC minimum and AGC maximum.

T-77-17

High Band Mixer Circuit

Figure 6 shows a basic outline of this circuit which performs mixing of luminance high band sections. Input of a contour correction signal at pin 18 of the pre-AGC, for

Sync Pulse Adder Circuit

The basic sync pulse adder circuit is shown in Figure 7. Besides being used to add sync pulses, a correction signal can be input at pin 33 to adjust the Y signal setup.

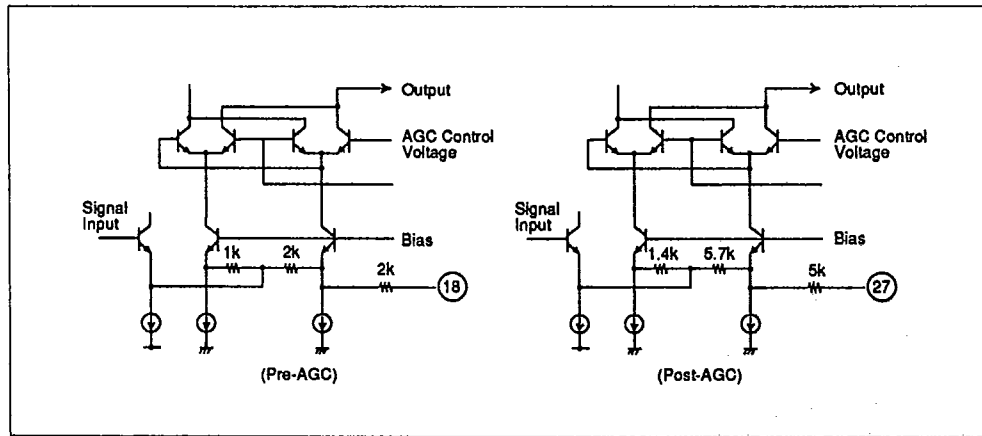

Figure 6. Basic High Band Mixing Circuit

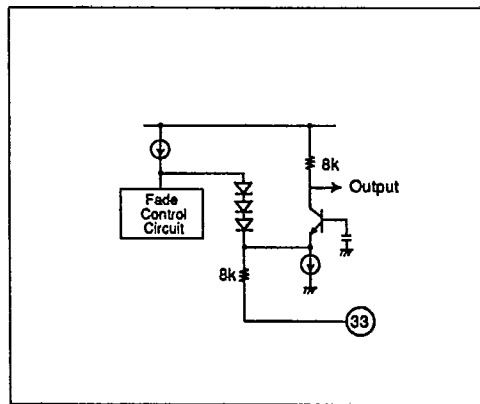

Figure 7. Basic Sync Pulse Adder Circuit



HA118082MA

T-77-17

Fade Circuit

With HA118082MA, simultaneous fade of Ych and Cch can be accomplished by applying the fade to Cch only. Figure 8 shows the fade control characteristics of Cch, which are identical to those for Ych.

After signal processing is performed by a 1-line read sensor, false color is generated at the vertical edge. Use Cch fade to cancel this false color.

Figure 9 shows Y signal level control characteristics when fade is ON. As shown, the screen brightness can be set to any level desired for the fade.

Chroma Gain Control

Figure 10 shows chroma gain control characteristics. The fade function is given priority while fade is ON.

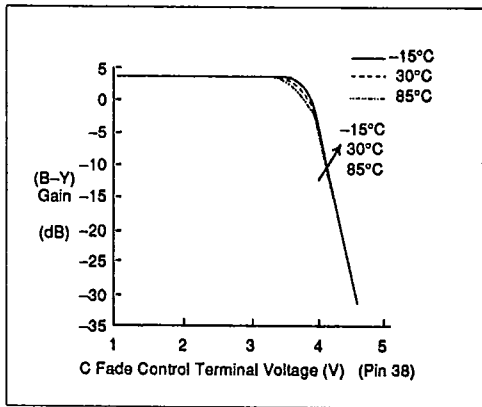

Figure 8. Chroma Fade Control Characteristics

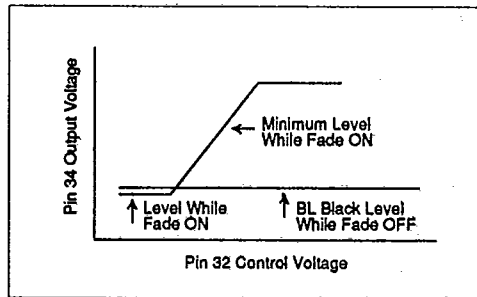

Figure 9. Fade Level Control

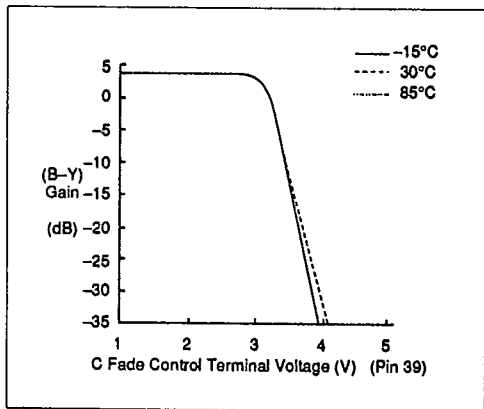

Figure 10. Chroma Gain Control Characteristics



HA118082MA

Low-illumination 3.58MHz Trap Circuit

In the Y signal, high frequency random noise in the vicinity of 3.58MHz causes deterioration of the color S/N ratio, especially under low illumination. HA118082MA includes a 3.58MHz trap to counteract this phenomena and improve image quality under low illumination conditions. This trap is designed to switch ON under low illumination (AGC 12dB). Operation hysteresis is applied so the switching of the trap is not noticeable on the screen. Figure 11 shows the trap circuit and characteristics. The trap is switched ON and OFF in accordance with changes in pin 29 input impedance, which varies according to illumination (AGC volume).

Red Brightness Correction Circuit

T-77-17

When a red object is shot, this circuit corrects the floating tendency of the Y signal. Figure 12 shows the circuit and its correction characteristics.

A signal (R - Y) is input to fix the black level, and, when the input level is high (high red saturation level), absorption current at Q4 increases to drop Ych output. The threshold level for this operation can be adjusted at pin 44.

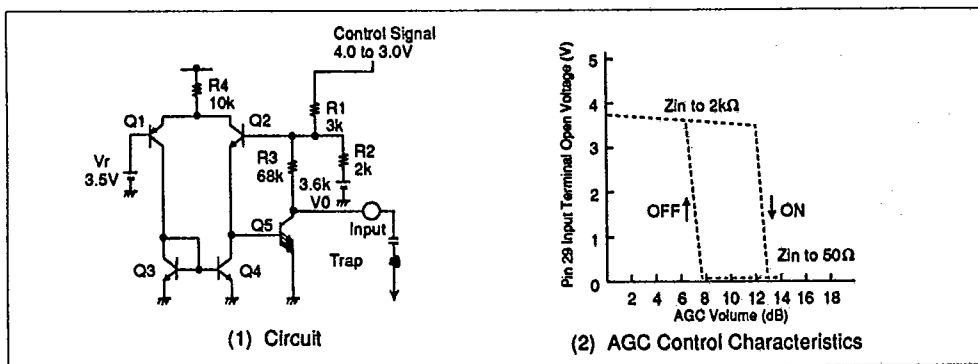

Figure 11. Low-illumination 3.58MHz Trap Circuit

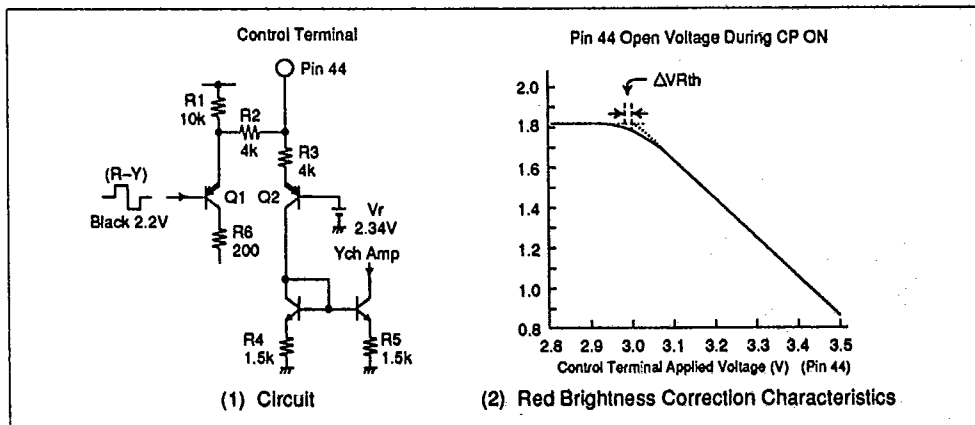

Figure 12. Red Brightness Correction Circuit



HA118082MA

T-77-17

Low-illumination Green Correction Circuit

This circuit is effective when it is necessary to suppress
GK gain under low illumination. Suppression can be
adjusted within the range of 0 to 2dB at pin 15.

