

HA12010

Fluorescent Tube Driver for Bar Graph Display

The Hitachi HA12010, encapsulated in 16-pin DIP, is a fluorescent display tube drivers specifically designed for linear-scale bar-graph display of VU-meters. Its features are as follows.

■ FEATURES

- No external component and perfect automatic adjustment.
- 12-point bar-graph display, linearly corresponding to input DC voltage with accuracy.
- High input impedance facilitates the connection with other circuit-blocks.
- 5mA max. of output current ($V_{CC} \leq 12V$)
- Wide range of supply voltage ($V_{CC} \cong 10$ to $24V$)
- 24-point bar-graph display available by using two HA12010's. (In the case of series-connection, the range of supply voltage is approx. 12 to 24V)

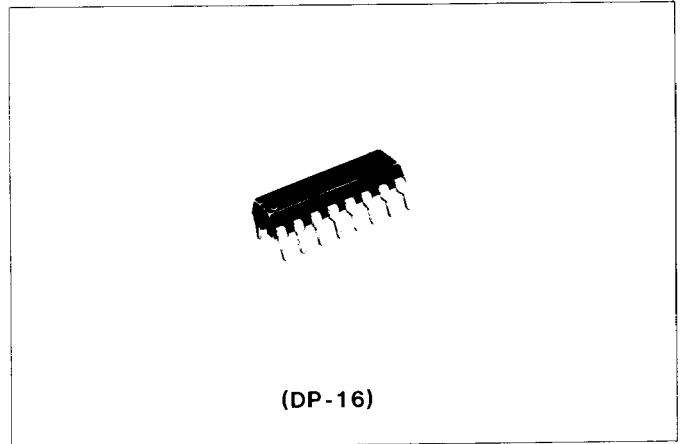

■ BLOCK DIAGRAM & TYPICAL APPLICATION CIRCUIT

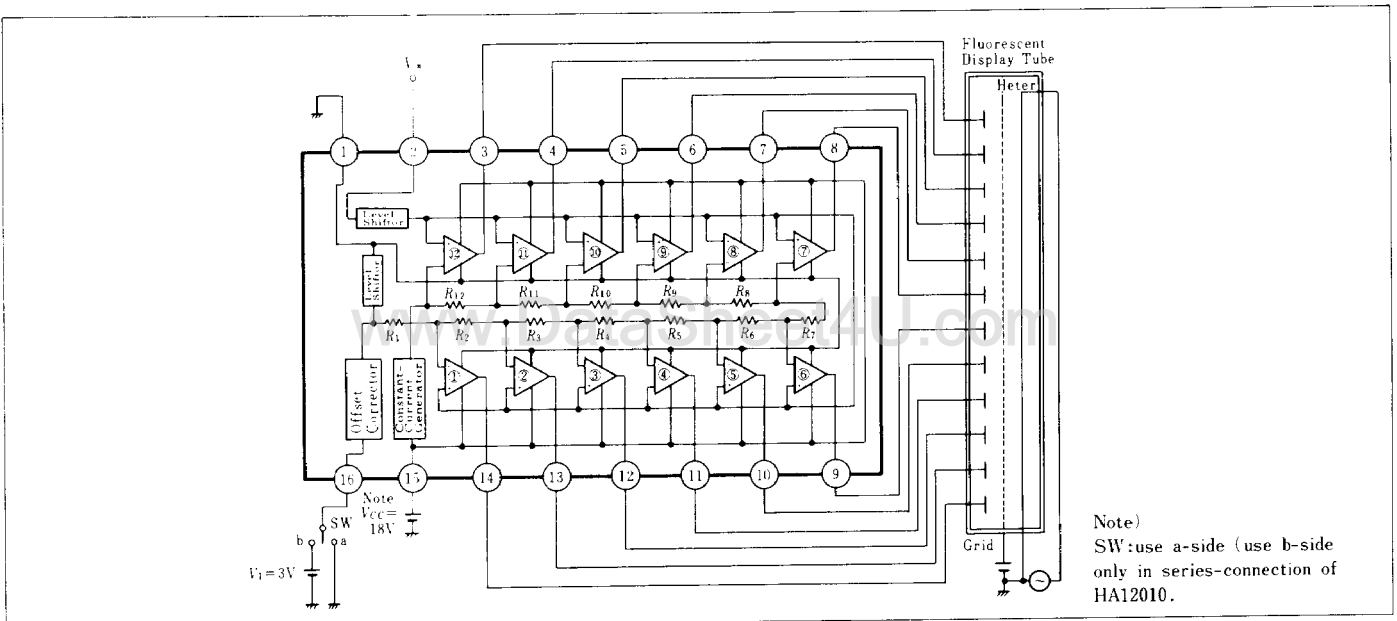

■ ABSOLUTE MAXIMUM RATINGS (Unless otherwise specified, $T_a = 25^\circ C$)

Item	Symbol	Rating	Unit	Note
Supply Voltage	V_{CC}	24	V	
Power Dissipation	P_T	550	mW	(1)
Operating Temperature Range	T_{opr}	-20 to +70	$^\circ C$	
Storage Temperature Range	T_{stg}	-55 to +125	$^\circ C$	
Max. Voltage at Pin-2	V_{2MAX}	16	V	(2)
Max. Voltage at Pin-16	V_{16MAX}	16	V	
Max. Voltage at Pins 3 to 14	V_{3MAX} to V_{14MAX}	23.5	V	(3)
Max. Output Current at Pins 3 to 14	I_{3MAX} to I_{14MAX}	5	mA	(4)

Notes: (1) Value at $T_a = 70^\circ C$

(2) Potential difference between pins 2 and 16: 7.0V or less.

(3) Under $V_{CC} = 24V$

Max. Voltage at Pins 3 to 14: ($V_{CC} = 0.5V$) or less.

(4) Under $V_{CC} \leq 12V$

See "Maximum Output Current vs. Supply Voltage".

MAXIMUM OUTPUT CURRENT vs. SUPPLY VOLTAGE

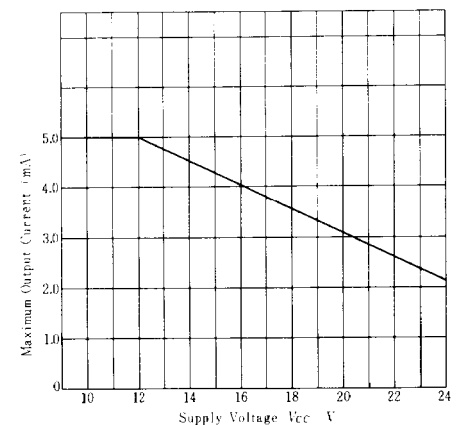

Note: Maximum Output Current: the maximum current supplied from the output pins (pins 3-14).



HA12010

■ ELECTRICAL CHARACTERISTICS

Item	Symbol	Test Conditions	min.	typ.	max.	Unit
Input Voltage	I_{IL}	Measure outflow current at pin-2 (input terminal) under pin-2 grounded.	—	2	300	nA
Pin-3 Threshold Voltage	V_{th3}	V_{in} under 15V of pin-3 voltage $R_L = 56k\Omega$	—	3.00	—	V
Pin-4 Threshold Voltage	V_{th4}	V_{in} under 15V of pin-4 voltage $R_L = 56k\Omega$	—	2.75	—	V
Pin-5 Threshold Voltage	V_{th5}	V_{in} under 15V of pin-5 voltage $R_L = 56k\Omega$	—	2.50	—	V
Pin-6 Threshold Voltage	V_{th6}	V_{in} under 15V of pin-6 voltage $R_L = 56k\Omega$	—	2.25	—	V
Pin-7 Threshold Voltage	V_{th7}	V_{in} under 15V of pin-7 voltage $R_L = 56k\Omega$	—	2.00	—	V
Pin-8 Threshold Voltage	V_{th8}	V_{in} under 15V of pin-8 voltage $R_L = 56k\Omega$	—	1.75	—	V
Pin-9 Threshold Voltage	V_{th9}	V_{in} under 15V of pin-9 voltage $R_L = 56k\Omega$	—	1.50	—	V
Pin-10 Threshold Voltage	V_{th10}	V_{in} under 15V of pin-10 voltage $R_L = 56k\Omega$	—	1.25	—	V
Pin-11 Threshold Voltage	V_{th11}	V_{in} under 15V of pin-11 voltage $R_L = 56k\Omega$	—	1.00	—	V
Pin-12 Threshold Voltage	V_{th12}	V_{in} under 15V of pin-12 voltage $R_L = 56k\Omega$	—	0.75	—	V
Pin-13 Threshold Voltage	V_{th13}	V_{in} under 15V of pin-13 voltage $R_L = 56k\Omega$	—	0.50	—	V
Voltage Difference between V_{th14} & GND	ΔV_{th1}	Measure the voltage difference between V_{th14} and Ground	0.220	0.250	0.280	V
Voltage Difference between V_{th13} & V_{th14} ($V_{th13} - V_{th14}$)	ΔV_{th2}	Measure the voltage difference between V_{th13} and V_{th14}	0.225	0.250	0.275	V
Voltage Difference between V_{th12} & V_{th13} ($V_{th12} - V_{th13}$)	ΔV_{th3}	Measure the voltage difference between V_{th12} and V_{th13}	0.225	0.250	0.275	V
Voltage Difference between V_{th11} & V_{th12} ($V_{th11} - V_{th12}$)	ΔV_{th4}	Measure the voltage difference between V_{th11} and V_{th12}	0.225	0.250	0.275	V
Voltage Difference between V_{th10} & V_{th11} ($V_{th10} - V_{th11}$)	ΔV_{th5}	Measure the voltage difference between V_{th10} and V_{th11}	0.225	0.250	0.275	V
Voltage Difference between V_{th9} & V_{th10} ($V_{th9} - V_{th10}$)	ΔV_{th6}	Measure the voltage difference between V_{th9} and V_{th10}	0.225	0.250	0.275	V
Voltage Difference between V_{th8} & V_{th9} ($V_{th8} - V_{th9}$)	ΔV_{th7}	Measure the voltage difference between V_{th8} and V_{th9}	0.225	0.250	0.275	V
Voltage Difference between V_{th7} & V_{th8} ($V_{th7} - V_{th8}$)	ΔV_{th8}	Measure the voltage difference between V_{th7} and V_{th8}	0.225	0.250	0.275	V
Voltage Difference between V_{th6} & V_{th7} ($V_{th6} - V_{th7}$)	ΔV_{th9}	Measure the voltage difference between V_{th6} and V_{th7}	0.225	0.250	0.275	V
Voltage Difference between V_{th5} & V_{th6} ($V_{th5} - V_{th6}$)	ΔV_{th10}	Measure the voltage difference between V_{th5} and V_{th6}	0.225	0.250	0.275	V
Voltage Difference between V_{th4} & V_{th5} ($V_{th4} - V_{th5}$)	ΔV_{th11}	Measure the voltage difference between V_{th4} and V_{th5}	0.225	0.250	0.275	V
Voltage Difference between V_{th3} & V_{th4} ($V_{th3} - V_{th4}$)	ΔV_{th12}	Measure the voltage difference between V_{th3} and V_{th4}	0.225	0.250	0.275	V
Operating Current	I_{CC}	Measure pin-15 inflow current under 0V of V_{in} at pin-2	—	8.0	14.3	mA
Output High-Voltage of pin-n	V_{OHn}	$V_{CC} = 12$, $n = 14$ to 3 4.0V is supplied to pin-2 (input terminal) under $R_L = 2.0k\Omega$	7.7	9.5	—	V
Output Leak Current of pin-n	I_{OLn}	$n = 14$ to 3, $V_{in}(\text{pin-2}) = 0V$	—	0.01	2	μA
Pin-14 Output Low-Voltage under 3V supplying to pin-16 (Referent terminal)	V_{OL14}	3.0V is supplied to pin-2 (input terminal) under 3.0V supplying to pin-16 (referent terminal) $R_L = 56k\Omega$	—	0.56	112	mV
Pin-3 Output High-Voltage under 3V supplying to pin-16 (Referent terminal)	V_{OH3}	7.0V is supplied to pin-2 (input terminal) under 3.0V supplying to pin-16 (referent terminal)	16.0	17.3	—	V
Pin-16 Outflow Current	I_{L16}	Measure pin-16 (referent terminal) outflow current	—	2	—	μA

Note) Unless otherwise specified, testing conditions are : $V_{CC} = 18.0V$,
 R_L (Load Resistance at pins 3 to 14) = $56k\Omega$, pin-1 = GND.

■ TEST CIRCUIT

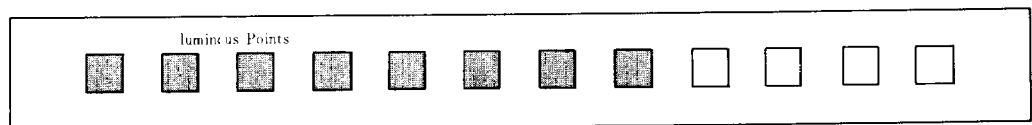
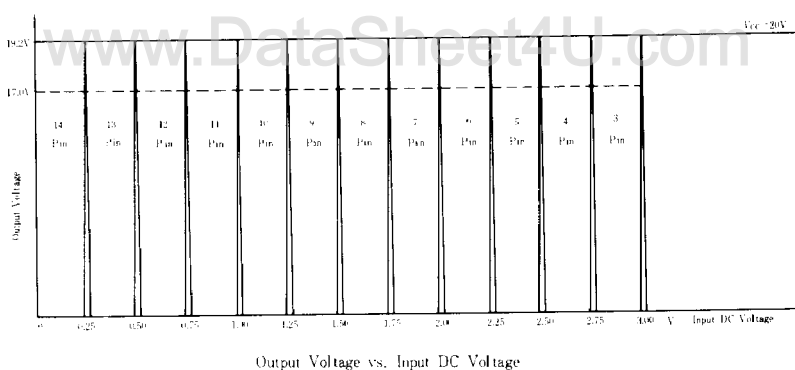
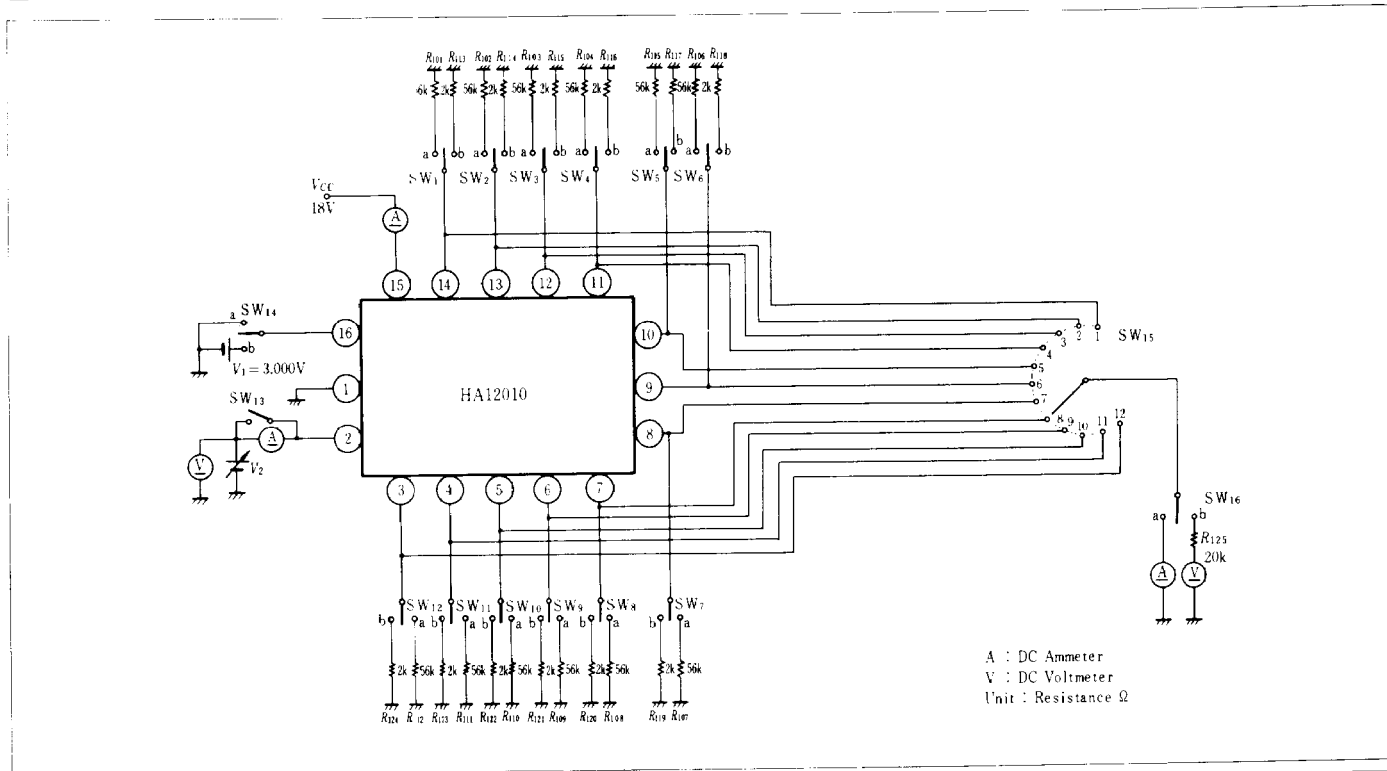

Fluorescent Display Tube under 2V of Input Voltage

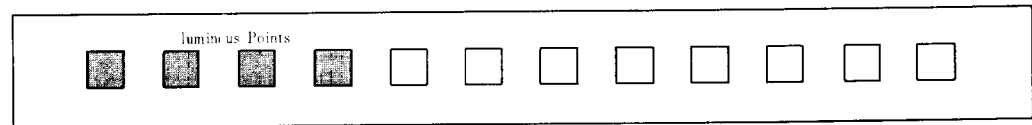

Fluorescent Display Tube under 1V of Input Voltage

HA12010 contains twelve voltage comparators as the diagram shows. Internal standard voltage which corresponds to each step is supplied to each comparator. When input DC voltage is higher than internal standard voltage, fluorescent display tube

will operate with high level output of fluorescent display tube driver connected to voltage comparator output. For instance, fig. shows 'Output Voltage vs. Input DC Voltage'.



HA12010

VU METER

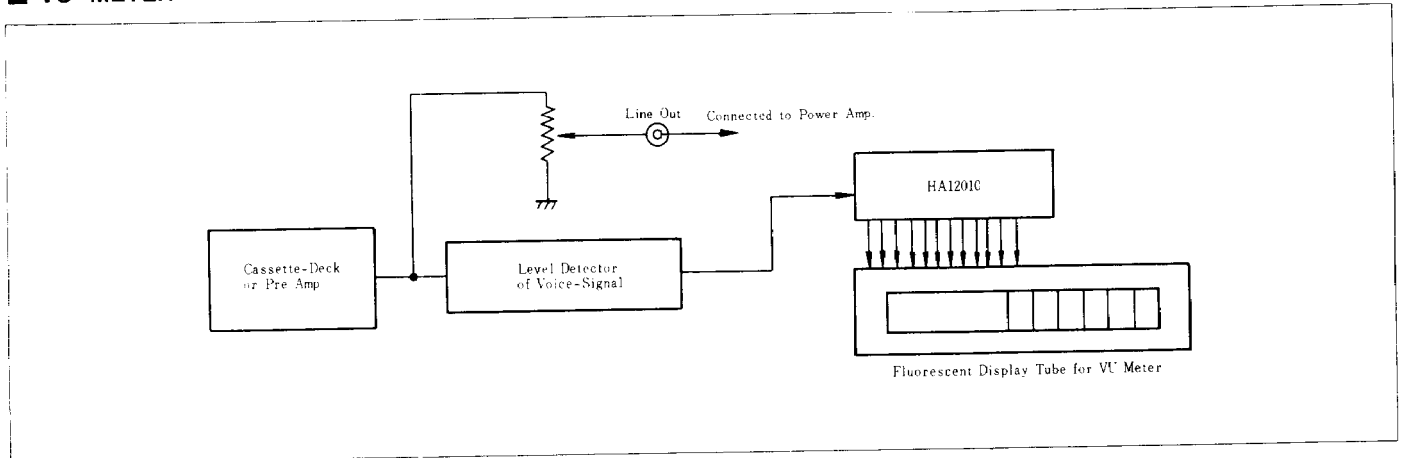

SERIES-CONNECTION OF HA12010

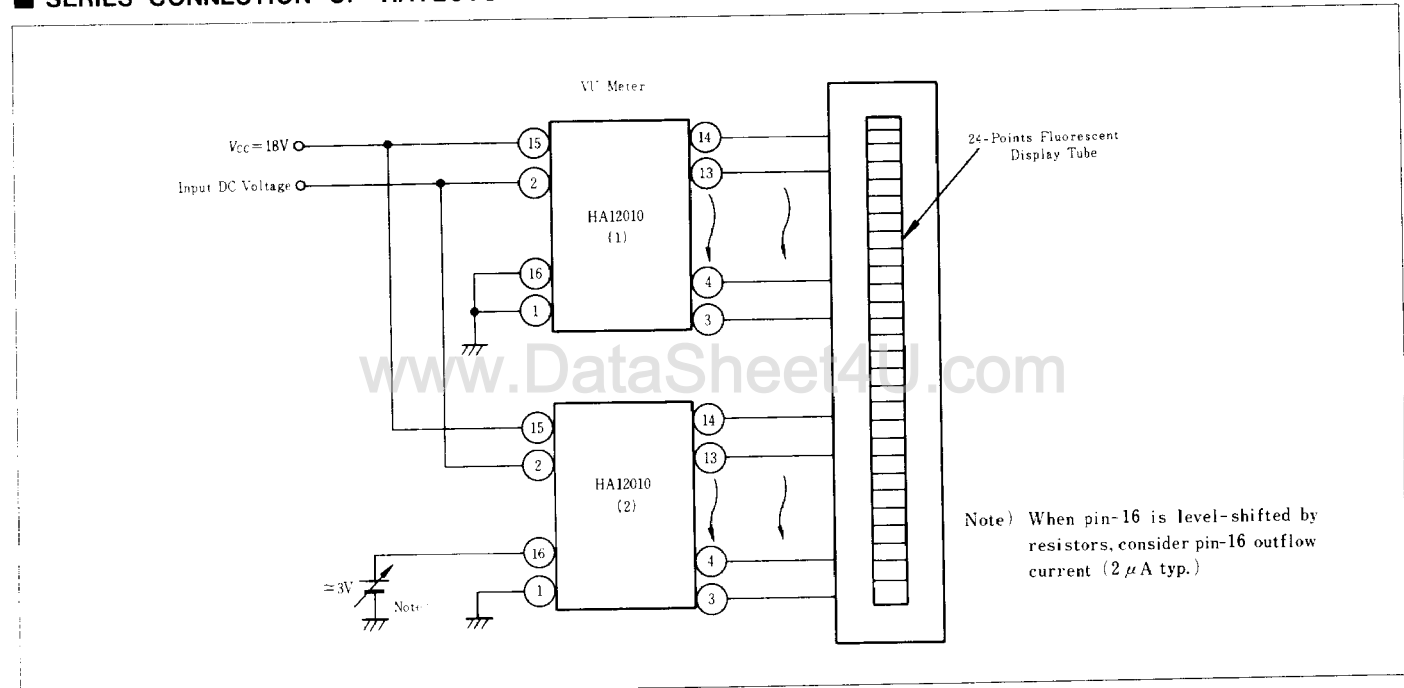

THRESHOLD VOLTAGE 14 TO 3 vs. SUPPLY VOLTAGE (1)

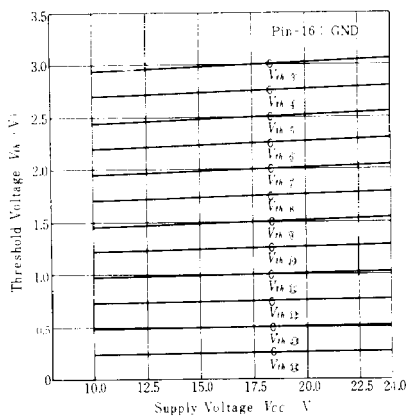

THRESHOLD VOLTAGE 14 TO 3 vs. SUPPLY VOLTAGE (2)

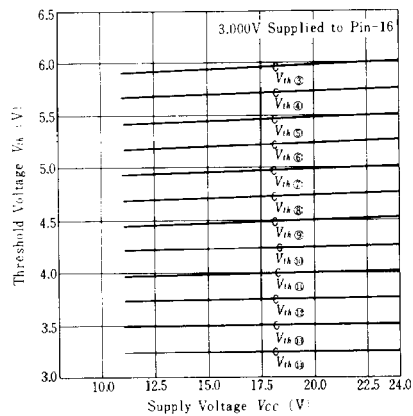

**THRESHOLD VOLTAGE 14 TO 3
vs. AMBIENT TEMPERATURE(1)**

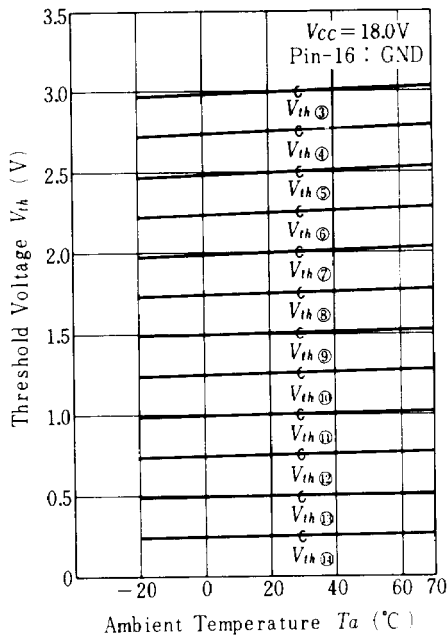

**THRESHOLD VOLTAGE 14 TO 3
vs. AMBIENT TEMPERATURE(2)**

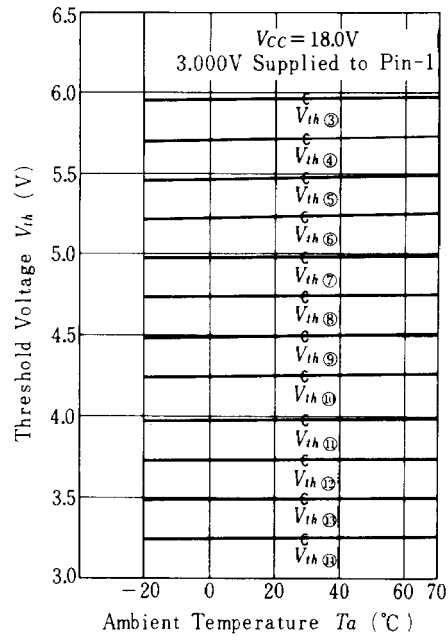

www.DataSheet4U.com

**OUTPUT HIGH-VOLTAGE
& OPERATING CURRENT
vs. AMBIENT TEMPERATURE**

