

# HA16670MP

## Position Signal Generator

### Description

The HA16670MP generates a position signal from the servo information from a hard disk.

A closed-loop servo controller can be implemented from a kit including the HA16671MP and HA16672MP VCM control ICs and the HA13447 VCM driver IC

### Functions

- Servo signal buffer amplifier
- Peak hold
- Servo sink detect circuit
- Offset switch
- Op amp for filter design

### Features

- Two power supply design (+5 V, +12 V)
- TTL-compatible digital inputs and outputs
- High bandwidth buffer amplifier (40 MHz typ)

### Ordering Information

Type No.	Package
HA16670MP	MP-44

### Block Diagram

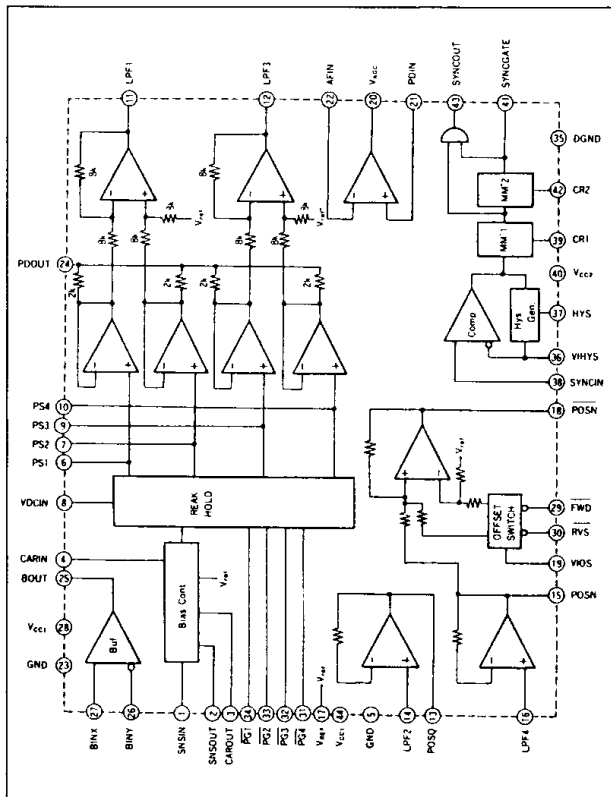

### HA16670MP

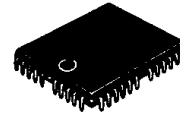

(MP-44)

### Pin Assignment

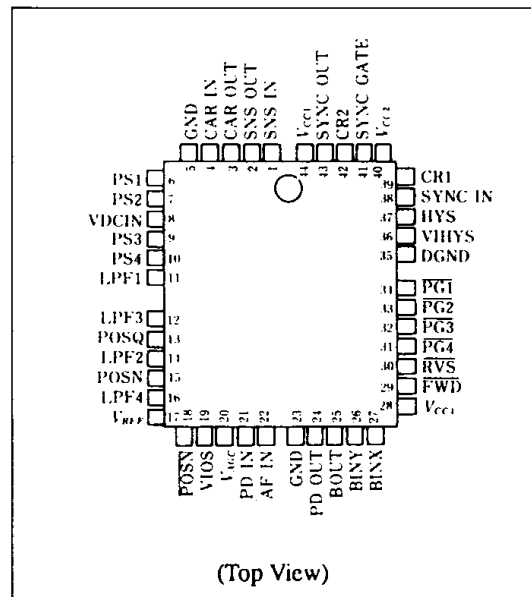

(Top View)



## Pin Description

Type	Pin No.	Name	Function
Power supply	28, 44	V <sub>CC1</sub>	+12-V power supply (analog)
	40	V <sub>CC2</sub>	+5-V power supply (logic)
	5, 23	GND	Analog GND
	35	DGND	Logic GND for logic circuits
Inputs	17	V <sub>REF</sub>	Reference voltage for peak hold and op amp
	27	BINX	Buffer amplifier servo differential signals
	26	BINY	
	4	CARIN	Bias control carrier signal
	1	SNSIN	Feedback for bias control
	34	PG1	Peak hold gate control
	33	PG2	Low: On = signal enable
	32	PG3	High: Off = signal disable
	31	PG4	
	21	PDIN	Non-inverting op amp for AGC
	22	AFIN	Inverting op amp for AGC
	14	LPF2	Voltage follower
	16	LPF4	
	30	RVS	Offset switch control
	29	FWD	Low: On High: Off
	19	VIOS	Offset switch offset voltage
	36	VIHYS	Hysteresis comparator amplitude control
38	SYNCIN	Hysteresis comparator servo signal	
Outputs	25	BOUT	Buffer amplifier
	3	CAROUT	Bias control carrier
	2	SNSOUT	Bias control feedback
	24	PDOUT	Peak hold output additive signal
	20	V <sub>AGC</sub>	AGC amplifier control voltage
	11	LPF1	Peak hold 1 and 2 differential amplifiers
	12	LPF3	Peak hold 3 and 4 differential amplifiers
	13	POSQ	Voltage follower for quadratic filter
	15	POSN	
	18	POSN	Inverted POSN plus offset switch
	37	HYS	Hysteresis comparator voltage waveform monitor
	41	SYNCGATE	MM#2 output pulsewidth monitor
	43	SYNCOUT	Sync pulse
External	6	PS1	Peak hold capacitor
Components	7	PS2	
	9	PS3	
	10	PS4	
	8	VDCIN	Resistor for setting peak hold discharge current
	39	CR1	Resistor and capacitor for setting MM#1 output pulsewidth
	42	CR2	Resistor and capacitor for setting MM#2 output pulsewidth

# HA16670MP

## Absolute Maximum Ratings (Ta = 25°C)

Parameter	Symbol	Rating	Unit	Applicable Pins
Power supply voltage 1	V <sub>CC1</sub>	15.0	V	V <sub>CC1</sub>
Power supply voltage 2	V <sub>CC2</sub>	7.0	V	V <sub>CC2</sub>
Input voltage 1	V <sub>I1</sub>	V <sub>CC2</sub>	V	PG1–PG4, FWD, RVS
Input voltage 2	V <sub>I2</sub>	V <sub>CC1</sub> – 1.5	V	LPF2, LPF4, PDIN, AFIN
Output current	I <sub>O</sub>	2	mA	LPF1, POSQ, LPF3, POSN, POSN, V <sub>AGC</sub>
Operating temperature	T <sub>opr</sub>	0 to +70	°C	
Storage temperature	T <sub>stg</sub>	–55 to +125	°C	

The absolute maximum ratings are limiting values, to be applied individually, beyond which the device may be permanently damaged. Functional operation under any of these conditions is not guaranteed. Exposing a circuit to its absolute maximum rating for extended periods of time may affect the device's reliability.

## Electrical Characteristics

(V<sub>CC</sub> = 12.0 V, V<sub>CC2</sub> = 5.0 V, Ta = 25°C, unless otherwise specified)

Parameter	Symbol	Min	Typ	Max	Unit	Test Conditions	Notes	
Power supply	Operating voltage 1	V <sub>CC1</sub>	10.8	12.0	13.2	V		
	Operating voltage 2	V <sub>CC2</sub>	4.5	5.0	5.5	V		
	Current consumption 1	I <sub>CC1</sub>	14	25	40	mA	V <sub>CC1</sub> = 13.2 V V <sub>CC2</sub> = 5.5 V	
	Current consumption 2	I <sub>CC2</sub>	19.5	31.2	46.0	mA	V <sub>CC1</sub> = 13.2 V V <sub>CC2</sub> = 5.5 V	
Buffer amplifier	Input bias voltage	V <sub>BB</sub>	3.5	3.8	4.15	V		
	In-phase output voltage	V <sub>CMB</sub>	8.9	9.3	9.7	V		
	Output sink current	I <sub>OSB</sub>	0.55	1.0	1.85	mA	V <sub>C</sub> = V <sub>CC1</sub> + 4 V V <sub>IB</sub> = V <sub>CC1</sub>	
	Voltage gain	A <sub>vB</sub>	4.3	5.0	5.6	V/V	f = 500 kHz	
	Bandwidth	BW	—	40	—	MHz	V <sub>IN</sub> = 200 mV <sub>p-p</sub> , –0.5 dB	
Bias circuit	Input bias current	I <sub>BR</sub>	—	90	450	nA		
	Input bias voltage	V <sub>IR</sub>	5.4	5.7	6.0	V	V <sub>REF</sub> = 5.0 V	
	Voltage gain	A <sub>VR</sub>	—	105	—	dB		2
Peak hold	Output offset voltage	V <sub>OSP</sub>	30	100	250	mV		
	Output clamp voltage	V <sub>OCL</sub>	2.65	3.1	3.55	V		
Op amp	Input offset current	I <sub>IO</sub>	—	1	200	nA		1
	Input offset voltage	V <sub>IO</sub>	—	0.1	9.0	mV		1
	In-phase input voltage	V <sub>CM</sub>	1.6	—	8.4	V		1
	In-phase output voltage	V <sub>OCM</sub>	1.6	—	8.4	V		1
	Slew rate	SR	—	2.6	—	V/μs		1
Sync pulse generator	Monostable multivibrator pulsewidth 1	T <sub>W1</sub>	—	56.5	—	ns	R <sub>T1</sub> = 56 Ω, R <sub>T2</sub> = 2.2 kΩ C <sub>T1</sub> = 120 pF, C <sub>T2</sub> = 150 pF	
	Monostable multivibrator pulsewidth 2	T <sub>W2</sub>	—	690	—	ns	V <sub>IN4</sub> = 2 V <sub>p-p</sub> , f = 3 MHz	
	Output fall time	t <sub>f</sub>	—	4	—	ns		
	Output rise time	t <sub>r</sub>	—	7	—	ns		

### Notes:

1. Characteristic values of the op amps built into the HA16670MP.
2. Open-loop gain for the bias circuit op amp.



Sample Application

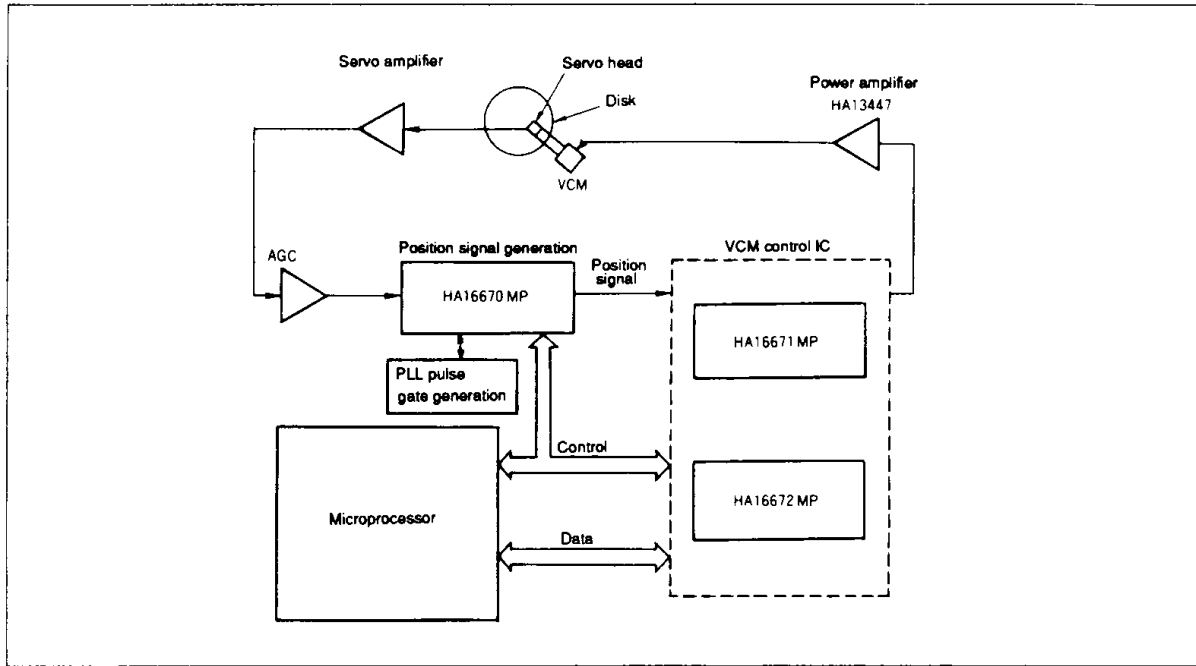

Servo Signal

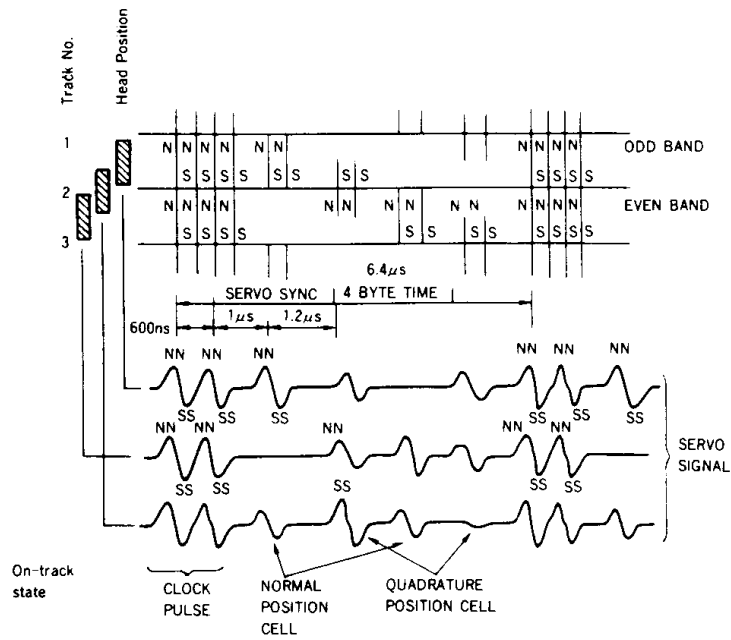

# HA16670MP

## Sample Circuit

