

**REPLACEMENT TYPE : MMBTA94**
**FEATURES**

- High Breakdown Voltage
- Complement to HABTA44 (NPN)

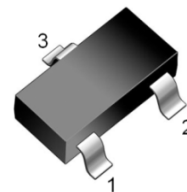

SOT-23 MARKING:4D

1: BASE 2: EMITTER 3: COLLECTOR

**MAXIMUM RATINGS (T<sub>A</sub> = 25°C unless otherwise noted)**

Parameter	Symbol	Value	Unit
Collector-Base Voltage	V <sub>CB0</sub>	-400	V
Collector-Emitter Voltage	V <sub>CEO</sub>	-400	V
Emitter-Base Voltage	V <sub>EBO</sub>	-5	V
Collector Current-Continuous	I <sub>C</sub>	-200	mA
Collector Power Dissipation	P <sub>C</sub>	350	mW
Junction Temperature	T <sub>J</sub>	150	°C
Storage Temperature	T <sub>stg</sub>	-55 to +150	°C

**ELECTRICAL CHARACTERISTICS (T<sub>A</sub> = 25°C unless otherwise noted)**

Parameter	Symbol	Test conditions	Min	Max	Unit
Collector-Base Breakdown Voltage	V <sub>CB0</sub>	I <sub>C</sub> =-100μA, I <sub>E</sub> =0	-400		V
Collector-Emitter Breakdown Voltage	V <sub>CEO</sub>	I <sub>C</sub> =-1mA, I <sub>B</sub> =0	-400		V
Emitter-Base Breakdown Voltage	V <sub>EBO</sub>	I <sub>E</sub> =-100μA, I <sub>C</sub> =0	-5		V
Collector Cut-off Current	I <sub>CBO</sub>	V <sub>CB</sub> =-400V, I <sub>E</sub> =0		-0.1	μA
Collector Cut-off Current	I <sub>CEO</sub>	V <sub>CE</sub> =-400V, I <sub>B</sub> =0		-5	μA
Emitter Cut-off Current	I <sub>EBO</sub>	V <sub>EB</sub> =-4V, I <sub>C</sub> =0		-0.1	μA
DC Current Gain	h <sub>FE(1)</sub>	V <sub>CE</sub> =-10V, I <sub>C</sub> =-10mA	80	300	
	h <sub>FE(2)</sub>	V <sub>CE</sub> =-10V, I <sub>C</sub> =-1mA	70		
	h <sub>FE(3)</sub>	V <sub>CE</sub> =-10V, I <sub>C</sub> =-100mA	40		
	h <sub>FE(4)</sub>	V <sub>CE</sub> =-10V, I <sub>C</sub> =-50mA	40		
Collector-Emitter Saturation Voltage	V <sub>CE(sat)1</sub>	I <sub>C</sub> =-10mA, I <sub>B</sub> =-1mA		-0.2	V
	V <sub>CE(sat)2</sub>	I <sub>C</sub> =-50mA, I <sub>B</sub> =-5mA		-0.3	V
Base-Emitter Saturation Voltage	V <sub>BE(sat)</sub>	I <sub>C</sub> =-10mA, I <sub>B</sub> =-1mA		-0.75	V
Transition Frequency	f <sub>T</sub>	V <sub>CE</sub> =-20V, I <sub>C</sub> =-10mA, f=30MHz	50		MHz

**CLASSIFICATION OF h<sub>FE</sub>**

Rank	L	H
Range	120-200	200-350

Typical Characteristics

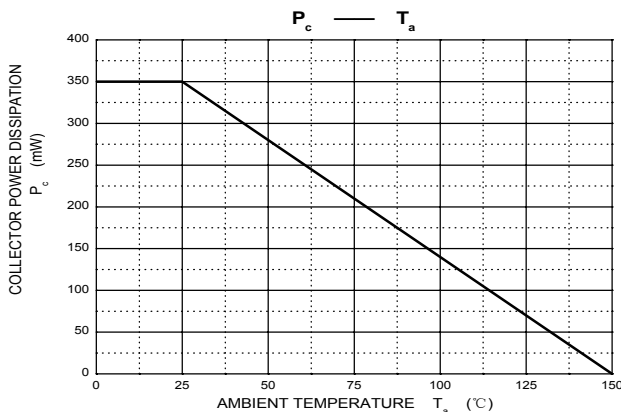
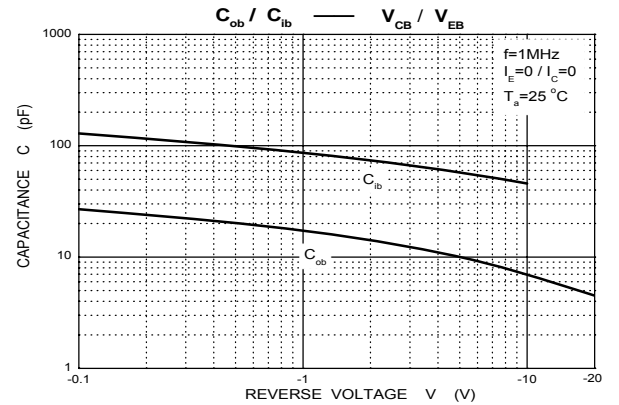
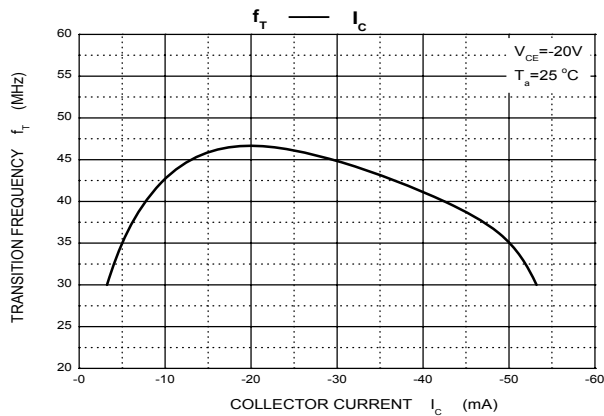
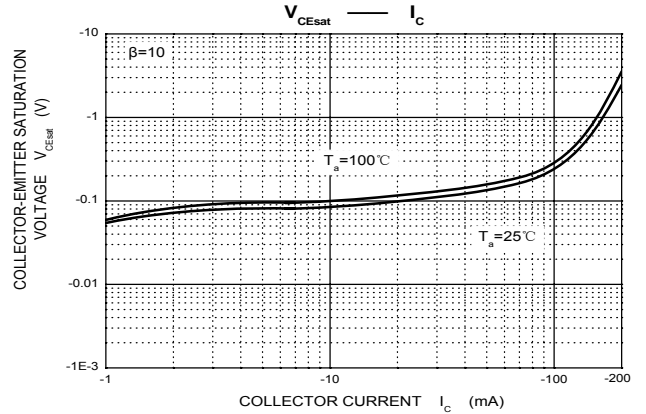
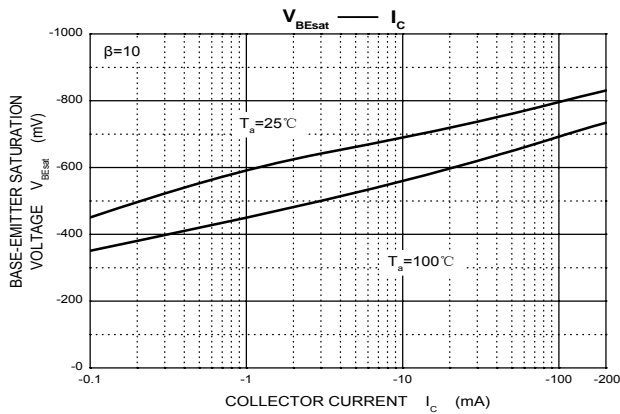
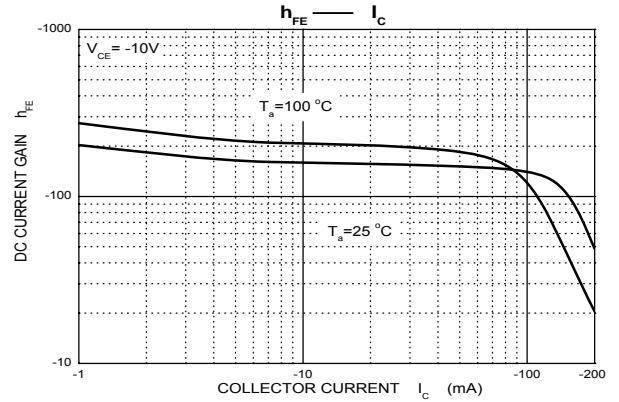
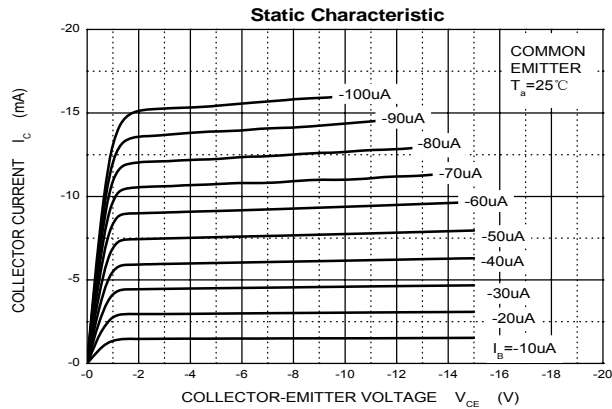

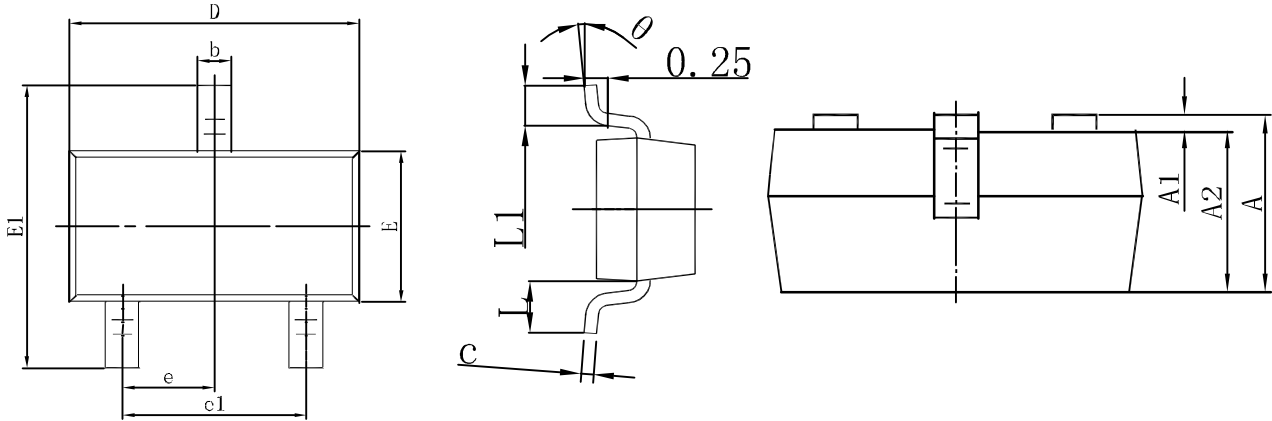
**Typical Characteristics**

Symbol	Dimensions In Millimeters		Dimensions In Inches	
	Min.	Max.	Min.	Max.
A	0.900	1.150	0.035	0.045
A1	0.000	0.100	0.000	0.004
A2	0.900	1.050	0.035	0.041
b	0.300	0.500	0.012	0.020
c	0.080	0.150	0.003	0.006
D	2.800	3.000	0.110	0.118
E	1.200	1.400	0.047	0.055
E1	2.250	2.550	0.089	0.100
e	0.950 TYP		0.037 TYP	
e1	1.800	2.000	0.071	0.079
L	0.550 REF		0.022 REF	
L1	0.300	0.500	0.012	0.020
θ	0°	8°	0°	8°

**SOT-23 Embossed Carrier Tape**

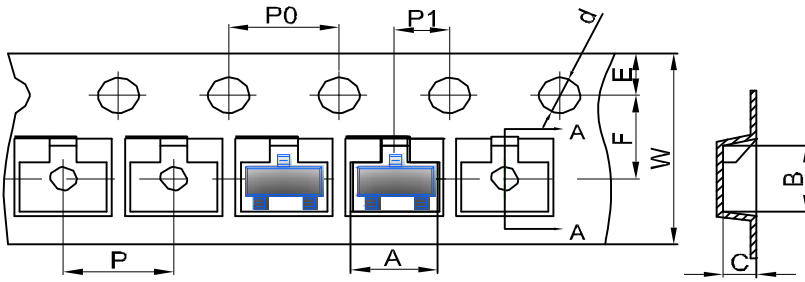

DIMENSIONS ARE IN MILLIMETER										
TYPE	A	B	C	d	E	F	P0	P	P1	W
SOT-23	3.15	2.77	1.22	φ1.50	1.75	3.50	4.00	4.00	2.00	8.00
TOLERANCE	±0.1	±0.1	±0.1	±0.1	±0.1	±0.1	±0.1	±0.1	±0.1	±0.1

**SOT-23 Tape Leader and Traller**

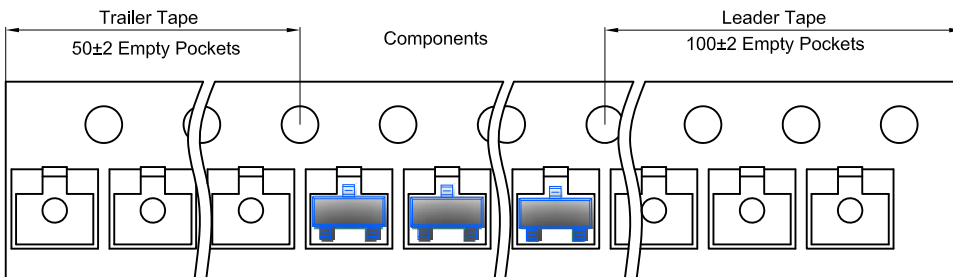

**SOT-23 Reel**

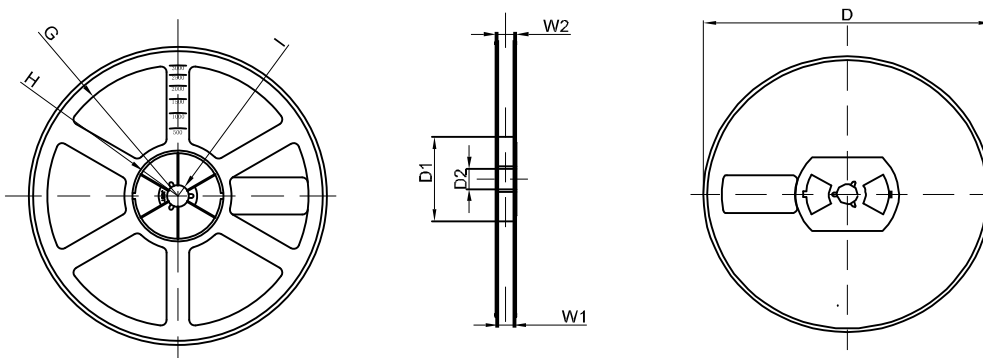

DIMENSIONS ARE IN MILLIMETER								
REEL OPTION	D	D1	D2	G	H	I	W1	W2
7" DIA	φ178	54.40	13.00	R78	R25.60	R6.50	9.50	12.30
TOLERANCE	±2	±1	±1	±1	±1	±1	±1	±1