

HIGH TEMPERATURE μ P COMPATIBLE 12-BIT A/D CONVERTER

HT574

FEATURES

- Specified Over -55 to +225°C
- Includes On-Chip Clock, Reference, μ P Interface and Sample/Hold
- 11-Bit Linearity
- 10 μ s Maximum Conversion, Including Acquisition
- Hermetic 28-Lead Ceramic DIP

APPLICATIONS

- Down-Hole Oil Well
- Avionics
- Turbine Engine Control
- Industrial Process Control
- Nuclear Reactor
- Electric Power Conversion
- Heavy Duty Internal Combustion Engines

GENERAL DESCRIPTION

The HT574 is a general purpose, 12-bit successive approximation A/D converter intended for applications with an extremely wide operating temperature range. Fabricated with Honeywell's dielectrically isolated high temperature (HTMOST™) process, it is designed specifically for severe high-temperature applications.

The HT574 includes a switched capacitor, digital-to-analog converter, internal reference, comparator, successive approximation register, sample and hold, oscillator and archi-

ture which allows it to be used with minimal external components. Tristate output buffers and digital control pins are also provided for microprocessor interfacing. Analog input signal ranges of 0 to +10V, 0 to +20V, or \pm 5V may be selected from the internal resistor scaling network.

The HT574 provides 12-bit conversions in 10 μ s over the entire -55 to +225°C temperature range. Typically, parts will operate up to +250°C for a year, with derated performance. All parts are burned in to eliminate infant mortality.

28-LEAD PACKAGE

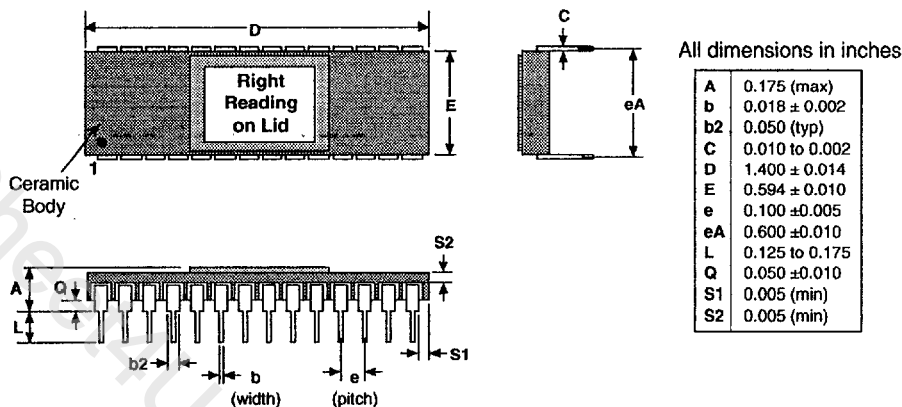

4551872 0001849 1T5

HT574

FUNCTIONAL DIAGRAM

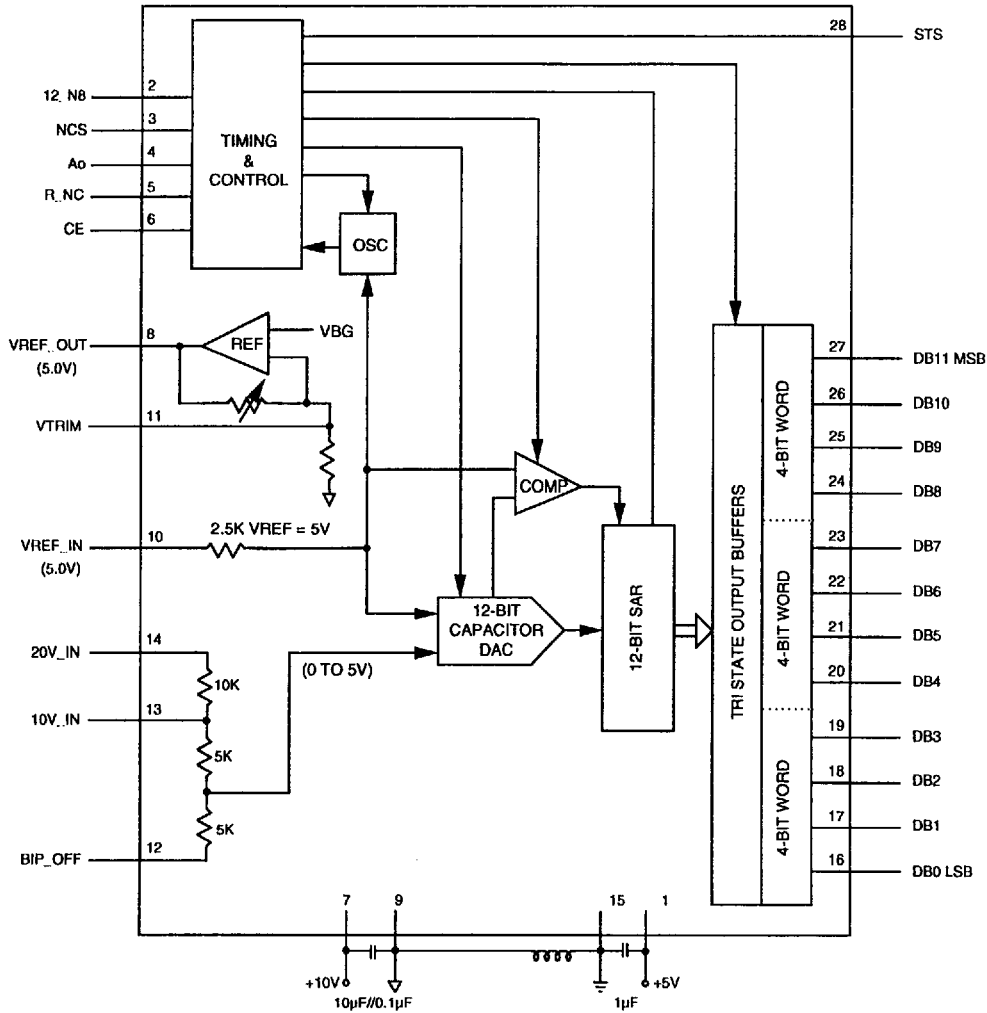

PINOUT DIAGRAM

NAME	FUNCTION
1 VLOGIC (+5V)	STS 28 Digital Supply (5V)
2 12_N8	DB11 27 Data Mode Select (1 = 12 bits; 0 = 8 bits)
3 NCS	DB10 26 Chip Select (Active Low)
4 Ao	DB9 25 Byte Size Select
5 R_NC	DB8 24 Read/Convert (1 = Read; 0 = Convert)
6 CE	DB7 23 Chip Enable (Active High)
7 VDD (+10V)	DB6 22 Analog Supply (10V)
8 VREF_OUT	DB5 21 Reference Output (5 V)
9 AGND	DB4 20 Analog Ground
10 VREF_IN	DB3 19 Reference Input
11 VTRIM	DB2 18 Trims Vref-out
12 BIP_OFF	DB1 17 Bipolar Offset
13 10V_IN	DB0 16 10 Volt Analog Input
14 20V_IN	DGND 15 20 Volt Analog Input
	DB0:11 12-Bit Digital Output (DB11 = MSB, DB0 = LSB)
	STS Status

DC ELECTRICAL CHARACTERISTICS

Max/min temperature ranges = -55 to +225°C,

Vlogic = 5.0V ± 10%, VDD = 10.0V ± 10%

Typical @ +25°C, Vlogic = +5V, VDD = +10V unless otherwise specified

Parameter	Conditions	Typ	Min	Max	Units
Resolution				12	Bits
Integral Non-Linearity (INL)	Tmin to Tmax			±1	LSB
Differential Non-Linearity (DNL)	Tmin to Tmax			±1	LSB
Unipolar Offset Error	Adjustable to zero			±2	LSB
Bipolar Offset Error	Adjustable to zero			±10	LSB
Full Scale Calibration Error (1)	No adjustment at +25°C, Tmin to Tmax	0.8			% of FS
	With adjustment at +25°C, Tmin to Tmax	0.5			% of FS
Temperature Coefficients	Using internal reference, Tmin to Tmax				
Unipolar Offset				±2 (5)	LSB (ppm/°C)
Bipolar Offset				±4 (10)	LSB (ppm/°C)
Full Scale Calibration				±20 (50)	LSB (ppm/°C)
Power Supply Rejection	Max change in full scale calibration			±2	LSB
				±0.5	LSB
+9.0V < VDD < 11V					
+4.5V < VLOGIC < 5.5V					
Analog Input Ranges (3)					
Bipolar			-5	+5	V
Unipolar: 10V_In			0	+10	V
Unipolar: 20V_In			0	+20	V
Impedance	Temperature coefficient = ±300ppm/°C				
10 Volt Span		2.50	2	3	KΩ
20 Volt Span		3.75	3	4.5	kΩ
Operating Voltage Range					
VLOGIC			+4.5	+5.5	V
VDD			+9	+11	V
Operating Current					
ILOGIC		.1		1	mA
IDD		2.5		8	mA
Power Dissipation	VDD = 10V, VLOGIC = 5 V	25.5		85	mW
Internal Reference Voltage		5	4.965	5.035	V
Output Current (2)	Sink or source			8	mA

(1) Can be adjusted by tying VTRIM to external resistor and VREF_OUT or AGND.

(2) Available for external loads, external load should not change during conversion.

(3) See figures on page 7.

HT574

DIGITAL CHARACTERISTICS

Max/min temperature ranges = -55 to +225°C,

Vlogic = 5.0V ± 10%, VDD = 10.0V ± 10%

Typical @ +25°C, Vlogic = +5V, VDD = +10V unless otherwise specified

Parameter	Conditions	Typical	Min	Max	Units
Logic Inputs (CE, NCS, R_NC, Ao, 12_N8)					
Logic "1"			2.4	5.5	V
Logic "0"			-0.5	+0.8	V
Current	0 to +5.5V input	±0.01		+5	µA
Capacitance		5			pF
Logic Outputs (DB11-DBO, STS)					
Logic "0"	(ISink = 1.6mA)			+0.4	V
Logic "1"	(ISource = 500µA)		+2.4		V
Leakage	(High Z state, DB11-DBO only)	±0.1	-5	+5	µA
Capacitance		5			pF

READ MODE AC TIMING CHARACTERISTICS

Temperature ranges = -55 to +225°C, VDD = 10.0V ±10%

Typical @ +25°C, Vlogic = +5V, unless otherwise specified

Symbol	Parameter	Conditions (1)	Typical	Min	Max	Units
tDD	Access Time from CE				150	ns
tHD	Data Valid after CE Low			25		ns
tHL	Output Float Delay				150	ns
tSSR	NCS to CE Setup		0	50		ns
tSRR	R_NC to CE Setup		0	0		ns
tSAR	Ao to CE Setup			50		ns
tHSR	NCS Valid after CE Low		0	0		ns
tHRR	R_NC High after CE Low		0	0		ns
tHAR	Ao Valid after CE Low			50		ns
tHS	STS Delay after Data Valid			300	1000	ns

(1) Time is measured from 50% level of digital transitions. Tested with a 100pF and 3kΩ load for high impedance to drive and tested with 10pF and 3kΩ load for drive to high impedance.

CONVERT MODE TIMING CHARACTERISTICS

Max/min temperature ranges = -55 to +225°C,

Vlogic = 5.0V ± 10%, VDD = 10.0V ± 10%

Typical @ +25°C, Vlogic = +5V, VDD = +10V unless otherwise specified

Symbol	Parameter	Conditions (1)	Typical	Min	Max	Units
tDSC	STS Delay from CE				200	ns
tHEC	CE Pulse Width			50		ns
tSSC	NCS to CE Setup			50		ns
tHCS	NCS Low during CE High			50		ns
tSRC	R_NC to CE Setup			50		ns
tHRC	R_NC Low during CE High			50		ns
tSAC	Ao to CE-Setup			0		ns
tHAC	Ao Valid during CE High			50		ns
tC	Conversion Time 12-Bit Cycle 8-Bit Cycle	Including Acquisition Tmin to Tmax Tmin to Tmax			10 7.2	μs μs

(1) Time is measured from 50% level of digital transitions. Tested with a 100pF and 3kΩ load for high impedance to drive and tested with 10pF and 3kΩ load for drive to high impedance.

CONVERT MODE TIMING DIAGRAM

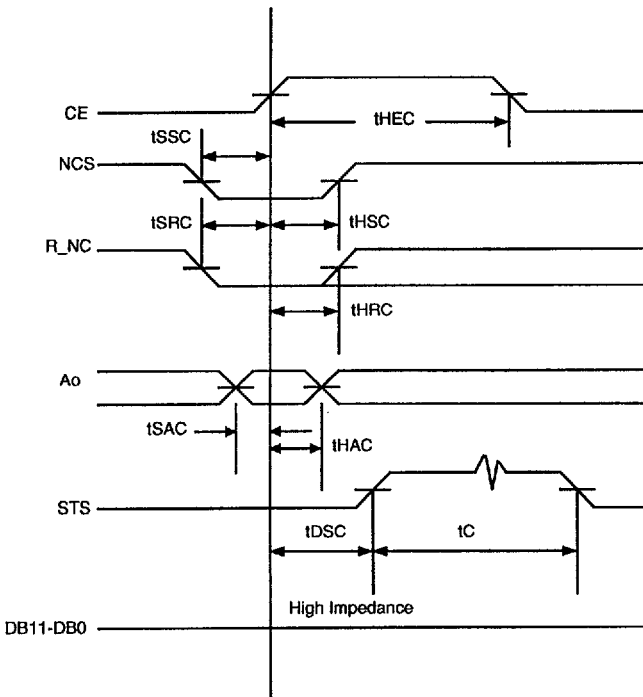

READ MODE TIMING DIAGRAM

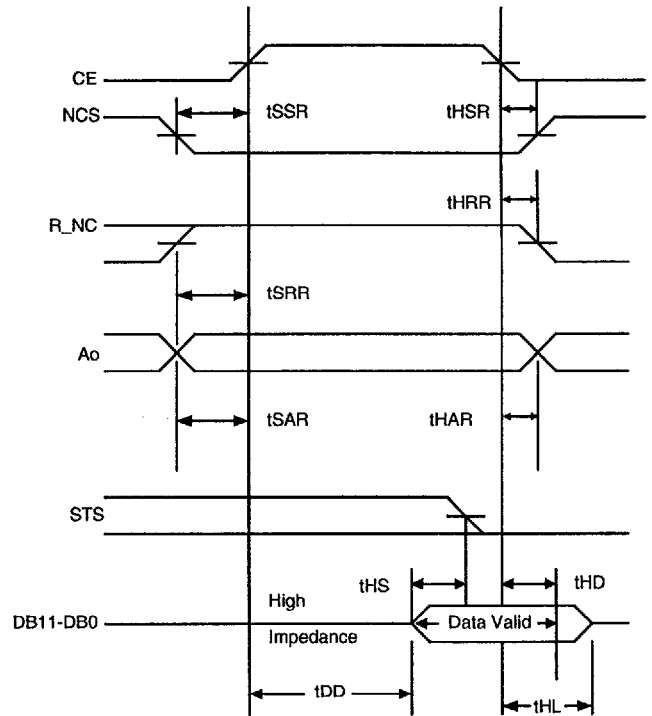

STAND ALONE MODE TIMING CHARACTERISTICS

Max/min temperature ranges = -55 to +225°C,

Vlogic = 5.0V ± 10%, VDD = 10.0V ± 10%

Typical @ +25°C, Vlogic = +5V, VDD = +10V unless otherwise specified

Symbol	Parameter	Conditions (1)	Typical	Min	Max	Units
tHRL	Low R_NC Pulse Width			50		ns
tDS	STS Delay from R_NC				200	ns
tHDR	Data Valid after R_NC Low			25		ns
tHS	STS Delay after Data Valid			300	1000	ns
tHRH	High R_NC Pulse Width			150		ns
tDDR	Data Access Time				150	ns

SAMPLE AND HOLD CHARACTERISTICS

-55 to 225°C, VDD = +10V, VLOGIC = +5V

Unless otherwise specified

Parameter	Conditions (1)	Typical	Min	Max	Units
Acquisition Time				1.26	µs
Aperture Uncertainty Time		20			ns

(1) Time is measured from 50% level of digital transitions. Tested with a 100pF and 3kΩ load for high impedance to drive and tested with 10pF and 3kΩ load for drive to high impedance.

STAND ALONE MODE TIMING LOW PULSE FOR R_NC

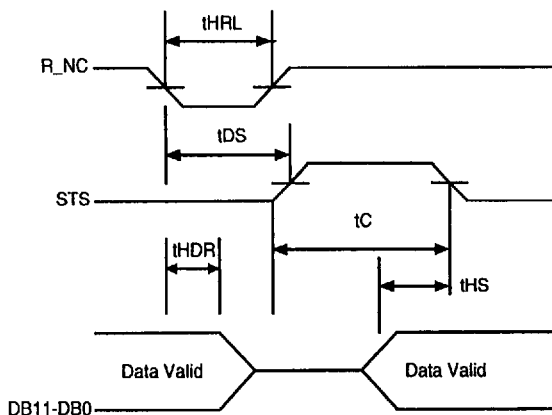

STAND ALONE MODE TIMING HIGH PULSE FOR R_NC

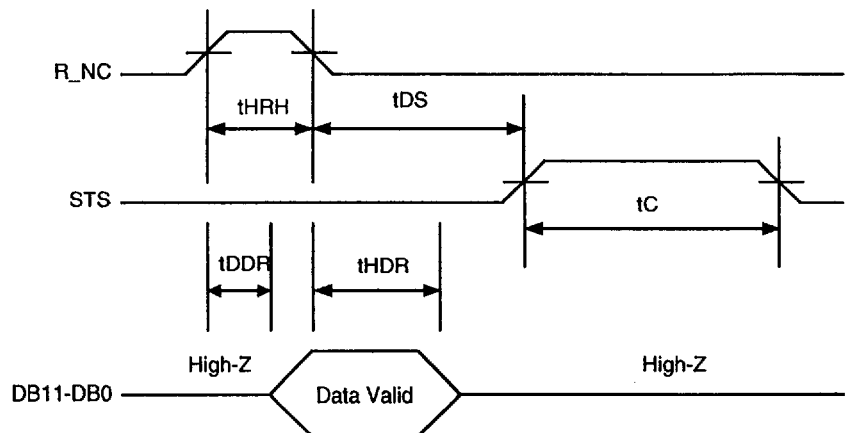

UNIPOLAR INPUT CONNECTIONS

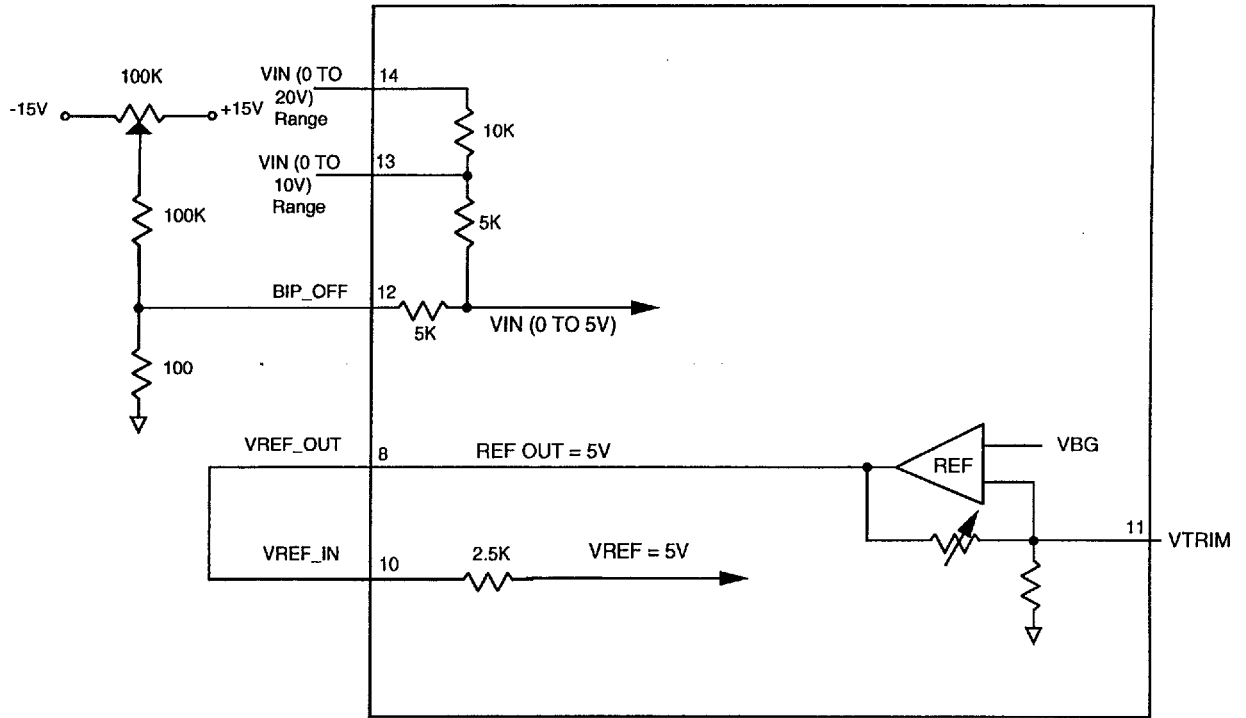

Note: If no offset adjustment is required, BIP_OFF can be tied directly to AGND (0 volts).

BIPOLAR INPUT CONNECTIONS

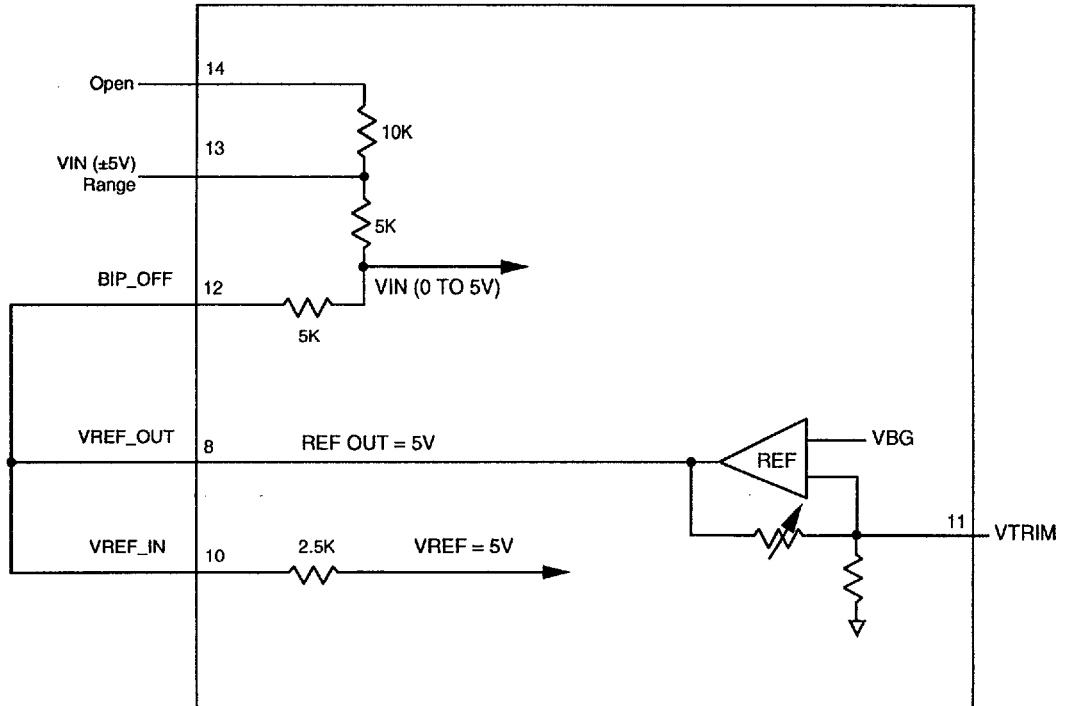

TRUTH TABLE FOR HT574 CONTROL

Case	CE	NCS	R_NC	12_N8	A0	Operation
1	0	X	X	X	X	None
2	X	1	X	X	X	None
3		0	0	X	0	Initiate 12 Bit Conversion
4		0	0	X	1	Initiate 8 Bit Conversion
5	1		0	X	0	Initiate 12 Bit Conversion
6	1		0	X	1	Initiate 8 Bit Conversion
7	1	0		X	0	Initiate 12 Bit Conversion
8	1	0		X	1	Initiate 8 Bit Conversion
9	1	0	1	1	X	Enable 12 Bit Output
10	1	0	1	0	0	Enable 8 MSB's Only
11	1	0	1	0	1	Enable 4 LSB's + 4 Trailing Zero's

ABSOLUTE MAXIMUM RATINGS (1)

VDD to Analog Common	0V to +12.5V
VLOGIC to Digital Common	0V to +7V
Analog Common to Digital Common	±1V
Control Inputs (CE, NCS, 12_N8, Ao, R_NC) to Digital Common	-0.5V to VLOGIC +0.5V
Analog Inputs (VREF_IN, BIP_OFF, 10V_IN) to Analog Common	±12.5V
20V_IN to Analog Common	±24V
VREF_OUT	Indefinite Short Circuit to Ground
Power Dissipation	1000mW
Storage Temperature	-65 to +250°C
Lead Temperature (Attachment, 10 sec.)	355°C
ESD Protection	2000V

(1) Stresses in excess of those listed above may result in permanent damage. These are stress ratings only, and operation at these levels is not implied. Frequent or extended exposure to absolute maximum conditions may effect device reliability.

**To learn more about Honeywell Solid State Electronics Center,
visit our web site at <http://www.ssec.honeywell.com>**

Honeywell reserves the right to make changes to any products or technology herein to improve reliability, function or design. Honeywell does not assume any liability arising out of the application or use of any product or circuit described herein; neither does it convey any license under its patent rights nor the rights of others.

Honeywell

Helping You Control Your World