HB56D473EJ Series

4,194,304-word × 72-bit High Density Dynamic RAM Module

HITACHI

ADE-203-725A (Z)

Rev. 1.0

Feb. 27, 1997

Description

The HB56D473EJ belongs to 8 Byte DIMM (Dual In-line Memory Module) family, and has been developed as an optimized main memory solution for 4 and 8 Byte processor applications. The HB56D473EJ is a 4M × 72 dynamic RAM module, mounted 16 pieces of 16-Mbit DRAM (HM5117400) sealed in SOJ package and 8 pieces of 4-Mbit DRAM (HM514100) sealed in SOJ package, 1 pieces of 16-bit BiCMOS line driver (74ABT16244) sealed in TSSOP package and 1 pieces of 20-bit BiCMOS line driver (74ABT16827) sealed in TSSOP package. An outline of the HB56D473EJ is 168-pin socket type package (dual lead out). Therefore, the HB56D473EJ makes high density mounting possible without surface mount technology. The HB56D473EJ provides common data inputs and outputs. Decoupling capacitors are mounted on the module board.

Features

- 168-pin socket type package (Dual lead out)
 - Outline: 133.35 mm (Length) × 25.40 mm (Height) × 9.00 mm (Thickness)
 - Lead pitch: 1.27 mm
- Single 5 V (±5%) supply
- High speed
 - Access time: $t_{RAC} = 60/70$ ns (max)
 - $t_{CAC} = 20/25$ ns (max)
- Low power dissipation
 - Active mode: 12.5/11.3 W (max)
 - Standby mode (TTL): 588 mW (max)
 - (CMOS): 462 mW (max)
- Buffered input except \overline{RAS} and DQ
- 4 byte interleave enabled, dual address input (A0/B0)
- JEDEC standard outline buffered 8-byte DIMM
- Fast page mode capability
- 2,048 refresh cycles: 32 ms



HB56D473EJ Series

- 2 variations of refresh
 - $\overline{\text{RAS}}$ -only refresh
 - $\overline{\text{CAS}}$ -before- $\overline{\text{RAS}}$ refresh
- TTL compatible

Ordering Information

Type No.	Access time	Package	Contact pad
HB56D473EJ-6	60 ns	168-pin dual lead out socket type	Gold
HB56D473EJ-7	70 ns		

Pin Arrangement

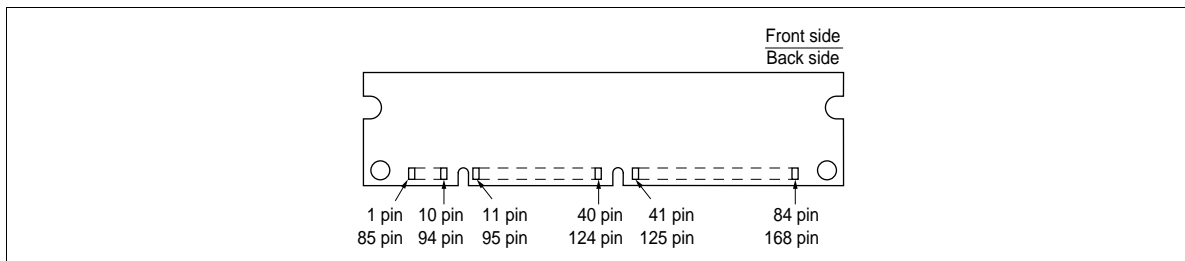

HB56D473EJ Series

Pin Arrangement

Pin No.	Pin name	Pin No.	Pin name	Pin No.	Pin name	Pin No.	Pin name
1	V _{SS}	43	V _{SS}	85	V _{SS}	127	V _{SS}
2	DQ0	44	$\overline{\text{OE2}}$	86	DQ36	128	NC
3	DQ1	45	$\overline{\text{RE2}}$	87	DQ37	129	NC
4	DQ2	46	$\overline{\text{CE4}}$	88	DQ38	130	$\overline{\text{CE5}}$
5	DQ3	47	$\overline{\text{CE6}}$	89	DQ39	131	$\overline{\text{CE7}}$
6	V _{CC}	48	$\overline{\text{WE2}}$	90	V _{CC}	132	$\overline{\text{PDE}}$
7	DQ4	49	V _{CC}	91	DQ40	133	V _{CC}
8	DQ5	50	NC	92	DQ41	134	NC
9	DQ6	51	NC	93	DQ42	135	NC
10	DQ7	52	DQ18	94	DQ43	136	DQ54
11	DQ8	53	DQ19	95	DQ44	137	DQ55
12	V _{SS}	54	V _{SS}	96	V _{SS}	138	V _{SS}
13	DQ9	55	DQ20	97	DQ45	139	DQ56
14	DQ10	56	DQ21	98	DQ46	140	DQ57
15	DQ11	57	DQ22	99	DQ47	141	DQ58
16	DQ12	58	DQ23	100	DQ48	142	DQ59
17	DQ13	59	V _{CC}	101	DQ49	143	V _{CC}
18	V _{CC}	60	DQ24	102	V _{CC}	144	DQ60
19	DQ14	61	NC	103	DQ50	145	NC
20	DQ15	62	NC	104	DQ51	146	NC
21	DQ16	63	NC	105	DQ52	147	NC
22	DQ17	64	NC	106	DQ53	148	NC
23	V _{SS}	65	DQ25	107	V _{SS}	149	DQ61
24	NC	66	DQ26	108	NC	150	DQ62
25	NC	67	DQ27	109	NC	151	DQ63
26	V _{CC}	68	V _{SS}	110	V _{CC}	152	V _{SS}
27	$\overline{\text{WE0}}$	69	DQ28	111	NC	153	DQ64
28	$\overline{\text{CE0}}$	70	DQ29	112	$\overline{\text{CE1}}$	154	DQ65
29	$\overline{\text{CE2}}$	71	DQ30	113	$\overline{\text{CE3}}$	155	DQ66
30	$\overline{\text{RE0}}$	72	DQ31	114	NC	156	DQ67
31	$\overline{\text{OE0}}$	73	V _{CC}	115	NC	157	V _{CC}
32	V _{SS}	74	DQ32	116	V _{SS}	158	DQ68
33	A0	75	DQ33	117	A1	159	DQ69
34	A2	76	DQ34	118	A3	160	DQ70

HB56D473EJ Series

Pin No.	Pin name	Pin No.	Pin name	Pin No.	Pin name	Pin No.	Pin name
35	A4	77	DQ35	119	A5	161	DQ71
36	A6	78	V _{SS}	120	A7	162	V _{SS}
37	A8	79	PD1	121	A9	163	PD2
38	A10	80	PD3	122	NC	164	PD4
39	NC	81	PD5	123	NC	165	PD6
40	V _{CC}	82	PD7	124	V _{CC}	166	PD8
41	NC	83	ID0 (NC)	125	NC	167	ID1 (V _{SS})
42	NC	84	V _{CC}	126	B0	168	V _{CC}

Pin Description

Pin name	Function
A0 to A10, B0	Address input <ul style="list-style-type: none"> — Row address : A0 to A10, B0 — Column address : A0 to A10, B0 — Refresh address (D0 to D15): A0 to A10, B0 — Refresh address (M0 to M7) : A0 to A9, B0
DQ0 to DQ71	Data-in/data-out
$\overline{RE0}$, $\overline{RE2}$	Row address strobe (\overline{RAS})
$\overline{CE0}$ to $\overline{CE7}$	Column address strobe (\overline{CAS})
$\overline{WE0}$, $\overline{WE2}$	Read/Write enable
$\overline{OE0}$, $\overline{OE2}$	Output enable
V _{CC}	Power supply
V _{SS}	Ground
PD1 to PD8	Presence detect
ID0, ID1	ID bit
\overline{PDE}	Presence detect enable
NC	No connection

Presence Detect Pin Assignment

Pin name	Pin No.	$\overline{\text{PDE}} = \text{Low}$		$\overline{\text{PDE}} = \text{High}$
		60 ns	70 ns	All
PD1	79	1	1	High-Z
PD2	163	1	1	High-Z
PD3	80	0	0	High-Z
PD4	164	1	1	High-Z
PD5	81	0	0	High-Z
PD6	165	1	0	High-Z
PD7	82	1	1	High-Z
PD8	166	1	1	High-Z

Note: 1: High level (driver output)
0: Low level (driver output)

HB56D473EJ Series

Block Diagram

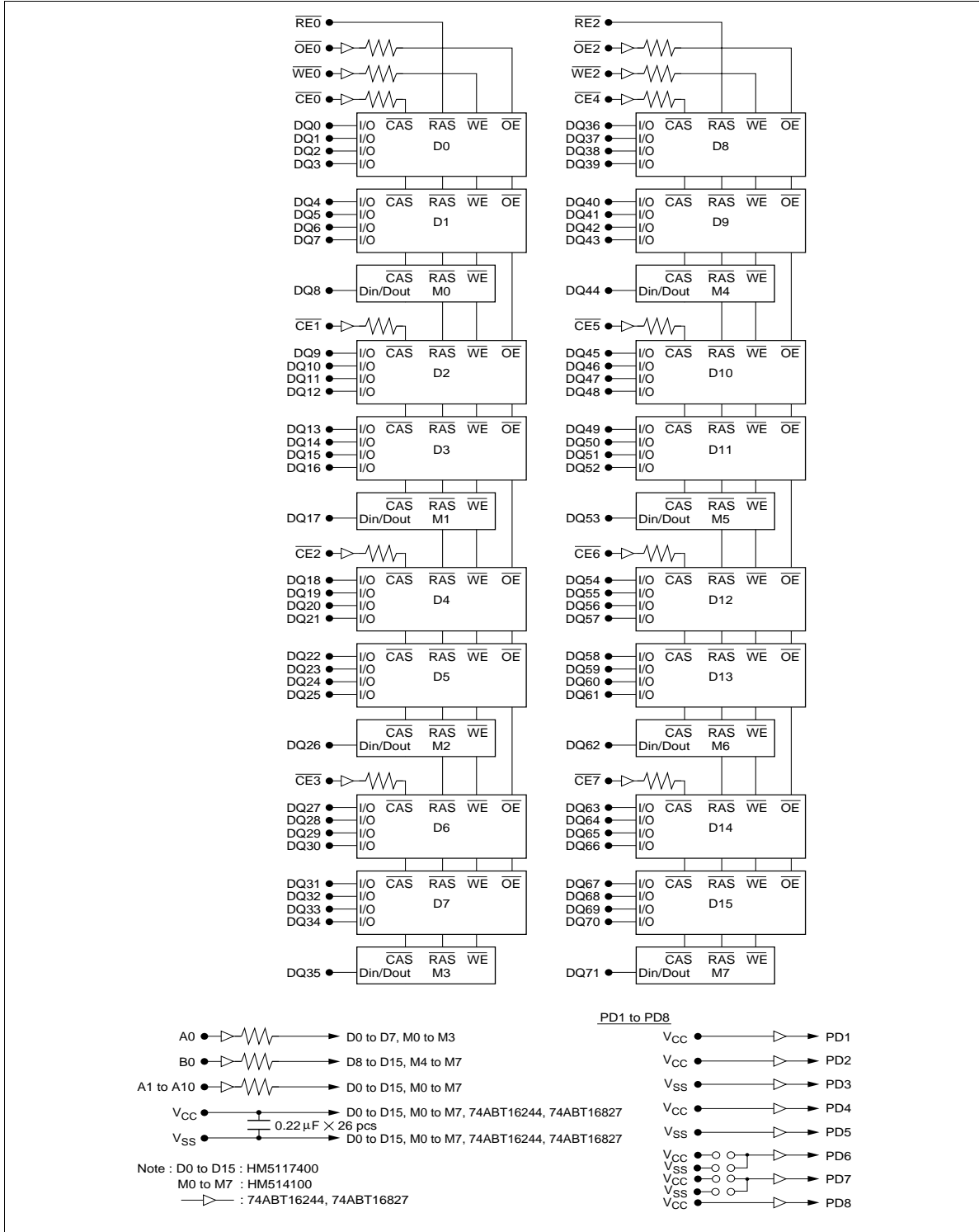

HB56D473EJ Series

Absolute Maximum Ratings

Parameter	Symbol	Value	Unit
Voltage on any pin relative to V_{SS}	V_T	-0.5 to +7.0	V
Supply voltage relative to V_{SS}	V_{CC}	-0.5 to +7.0	V
Short circuit output current	I_{out}	50	mA
Power dissipation	P_t	25	W
Operating temperature	T_{opr}	0 to +70	°C
Storage temperature	T_{stg}	-55 to +125	°C

Recommended DC Operating Conditions ($T_a = 0$ to 70°C)

Parameter	Symbol	Min	Typ	Max	Unit	Note
Supply voltage	V_{SS}	0	0	0	V	
	V_{CC}	4.75	5.0	5.25	V	1
Input high voltage	V_{IH}	2.4	—	5.5	V	1
Input low voltage	V_{IL}	-0.5	—	0.8	V	1

Note: 1. All voltage referred to V_{SS} .

HB56D473EJ Series

DC Characteristics (Ta = 0 to 70°C, V_{CC} = 5 V ± 5%, V_{SS} = 0 V)

Parameter	Symbol	60 ns		70 ns		Unit	Test conditions	Notes
		Min	Max	Min	Max			
Operating current	I _{CC1}	—	2384	—	2144	mA	t _{RC} = min	1, 2
Standby current	I _{CC2}	—	112	—	112	mA	TTL interface R _{AS} , C _{AS} = V _{IH} Dout = High-Z	
		—	88	—	88	mA	CMOS interface R _{AS} , C _{AS} ≥ V _{CC} - 0.2 V Dout = High-Z	
R _{AS} -only refresh current	I _{CC3}	—	2384	—	2144	mA	t _{RC} = min	2
Standby current	I _{CC5}	—	184	—	184	mA	R _{AS} = V _{IH} , C _{AS} = V _{IL} Dout = enable	1
C _{AS} -before-R _{AS} refresh current	I _{CC6}	—	2384	—	2144	mA	t _{RC} = min	
Fast page mode current	I _{CC7}	—	2224	—	1984	mA	t _{PC} = min	1, 3
Input leakage current	I _{LI}	-10	10	-10	10	μA	0 V ≤ Vin ≤ 5.5 V	
Output leakage current	I _{LO}	-10	10	-10	10	μA	0 V ≤ Vout ≤ 5.5 V Dout = disable	
Output high voltage	V _{OH}	2.4	V _{CC}	2.4	V _{CC}	V	High Iout = -5 mA	
Output low voltage	V _{OL}	0	0.4	0	0.4	V	Low Iout = 4.2 mA	

- Notes: 1. I_{CC} depends on output load condition when the device is selected, I_{CC} max is specified at the output open condition.
 2. Address can be changed once or less while R_{AS} = V_{IL}.
 3. Address can be changed once or less while C_{AS} = V_{IH}.

Capacitance (Ta = 25°C, V_{CC} = 5 V ± 5%)

Parameter	Symbol	Typ	Max	Unit	Notes
Input capacitance (Address)	C _{I1}	—	20	pF	1
Input capacitance (C _{AS} , WE, OE)	C _{I2}	—	20	pF	1
Input capacitance (R _{AS})	C _{I3}	—	99	pF	1
I/O capacitance (DQ0 to DQ7, DQ9 to DQ16, DQ18 to DQ25, DQ27 to DQ34, DQ36 to DQ43, DQ45 to DQ52, DQ54 to DQ61, DQ63 to DQ70)	C _{I/O1}	—	20	pF	1, 2
I/O capacitance (DQ8, DQ17, DQ26, DQ35, DQ44, DQ53, DQ62, DQ71)	C _{I/O2}	—	25	pF	1, 2

- Notes: 1. Capacitance measured with Boonton Meter or effective capacitance measuring method.
 2. C_{AS} = V_{IH} to disable Dout.

HB56D473EJ Series

AC Characteristics ($T_a = 0$ to 70°C , $V_{CC} = 5\text{ V} \pm 5\%$, $V_{SS} = 0\text{ V}$)*^{1, *2}

Test Conditions

- Input rise and fall times: 5 ns
- Input timing reference levels: 0.8 V, 2.4 V
- Output timing reference levels: 0.4 V, 2.4 V
- Output load: 2 TTL gate + C_L (100 pF) (Including scope and jig)

Read, Write and Refresh Cycles (Common parameters)

Parameter	Symbol	60 ns		70 ns		Unit	Notes
		Min	Max	Min	Max		
Random read or write cycle time	t_{RC}	110	—	130	—	ns	
$\overline{\text{RAS}}$ precharge time	t_{RP}	40	—	50	—	ns	
$\overline{\text{CAS}}$ precharge time	t_{CP}	10	—	10	—	ns	
$\overline{\text{RAS}}$ pulse width	t_{RAS}	60	10000	70	10000	ns	
$\overline{\text{CAS}}$ pulse width	t_{CAS}	15	10000	20	10000	ns	
Row address setup time	t_{ASR}	5	—	5	—	ns	
Row address hold time	t_{RAH}	10	—	10	—	ns	
Column address setup time	t_{ASC}	0	—	0	—	ns	
Column address hold time	t_{CAH}	15	—	15	—	ns	
$\overline{\text{RAS}}$ to $\overline{\text{CAS}}$ delay time	t_{RCD}	20	40	20	45	ns	3
$\overline{\text{RAS}}$ to column address delay time	t_{RAD}	15	25	15	30	ns	4
$\overline{\text{RAS}}$ hold time	t_{RSH}	20	—	25	—	ns	
$\overline{\text{CAS}}$ hold time	t_{CSH}	60	—	70	—	ns	
$\overline{\text{CAS}}$ to $\overline{\text{RAS}}$ precharge time	t_{CRP}	15	—	15	—	ns	
$\overline{\text{OE}}$ to Din delay time	t_{OED}	20	—	25	—	ns	5, 18
$\overline{\text{OE}}$ delay time from Din	t_{DZO}	0	—	0	—	ns	6, 18
$\overline{\text{CAS}}$ delay time from Din	t_{DZC}	0	—	0	—	ns	6
Transition time (rise and fall)	t_T	3	50	3	50	ns	7
Refresh period (2,048 cycles)	t_{REF}	—	32	—	32	ms	

HB56D473EJ Series

Read Cycle

Parameter	Symbol	60 ns		70 ns		Unit	Notes
		Min	Max	Min	Max		
Access time from $\overline{\text{RAS}}$	t_{RAC}	—	60	—	70	ns	8, 9
Access time from $\overline{\text{CAS}}$	t_{CAC}	—	20	—	25	ns	9, 10, 17
Access time from address	t_{AA}	—	35	—	40	ns	9, 11, 17
Access time from $\overline{\text{OE}}$	t_{OEA}	—	20	—	25	ns	9, 18
Read command setup time	t_{RCS}	0	—	0	—	ns	
Read command hold time to $\overline{\text{CAS}}$	t_{RCH}	0	—	0	—	ns	12
Read command hold time to $\overline{\text{RAS}}$	t_{RRH}	5	—	5	—	ns	12
Column address to $\overline{\text{RAS}}$ lead time	t_{RAL}	35	—	40	—	ns	
Column address to $\overline{\text{CAS}}$ lead time	t_{CAL}	30	—	35	—	ns	
$\overline{\text{CAS}}$ to output in low-Z	t_{CLZ}	2	—	2	—	ns	
Output data hold time	t_{OH}	3	—	3	—	ns	
Output data hold time from $\overline{\text{OE}}$	t_{OHO}	3	—	3	—	ns	18
Output buffer turn-off time	t_{OFF}	—	20	—	25	ns	13
Output buffer turn-off to $\overline{\text{OE}}$	t_{OEZ}	—	20	—	25	ns	13, 18
$\overline{\text{CAS}}$ to Din delay time	t_{CDD}	20	—	25	—	ns	5

Write Cycle

Parameter	Symbol	60 ns		70 ns		Unit	Notes
		Min	Max	Min	Max		
Write command setup time	t_{WCS}	0	—	0	—	ns	14
Write command hold time	t_{WCH}	15	—	15	—	ns	
Write command pulse width	t_{WP}	10	—	10	—	ns	
Data-in setup time	t_{DS}	0	—	0	—	ns	15
Data-in hold time	t_{DH}	20	—	20	—	ns	15

HB56D473EJ Series

Refresh Cycle

Parameter	Symbol	60 ns		70 ns		Unit	Notes
		Min	Max	Min	Max		
$\overline{\text{CAS}}$ setup time (CBR refresh cycle)	t_{CSR}	15	—	15	—	ns	
$\overline{\text{CAS}}$ hold time (CBR refresh cycle)	t_{CHR}	10	—	10	—	ns	
$\overline{\text{WE}}$ setup time (CBR refresh cycle)	t_{WRP}	5	—	5	—	ns	
$\overline{\text{WE}}$ hold time (CBR refresh cycle)	t_{WRH}	10	—	10	—	ns	
RAS precharge to $\overline{\text{CAS}}$ hold time	t_{RPC}	10	—	10	—	ns	

Fast Page Mode Cycle

Parameter	Symbol	60 ns		70 ns		Unit	Notes
		Min	Max	Min	Max		
Fast page mode cycle time	t_{PC}	40	—	45	—	ns	
Fast page mode $\overline{\text{RAS}}$ pulse width	t_{RASP}	—	100000	—	100000	ns	16
Access time from $\overline{\text{CAS}}$ precharge	t_{CPA}	—	40	—	45	ns	9, 17
$\overline{\text{RAS}}$ hold time from $\overline{\text{CAS}}$ precharge	t_{CPRH}	40	—	45	—	ns	

HB56D473EJ Series

- Notes:
1. AC measurements assume $t_r = 5$ ns.
 2. An initial pause of 200 μ s is required after power up followed by a minimum of eight initialization cycles (any combination of cycles containing RAS-only refresh cycle or CAS-before-RAS refresh). If the internal refresh counter is used, a minimum of eight CAS-before-RAS refresh cycles are required.
 3. Operation with the t_{RCD} (max) limit insures that t_{RAC} (max) can be met, t_{RCD} (max) is specified as a reference point only; if t_{RCD} is greater than the specified t_{RCD} (max) limit, then access time is controlled exclusively by t_{CAC} .
 4. Operation with the t_{RAD} (max) limit insures that t_{RAC} (max) can be met, t_{RAD} (max) is specified as a reference point only; if t_{RAD} is greater than the specified t_{RAD} (max) limit, then access time is controlled exclusively by t_{AA} .
 5. Either t_{OED} or t_{CDD} must be satisfied.
 6. Either t_{DZO} or t_{DZC} must be satisfied.
 7. V_{IH} (min) and V_{IL} (max) are reference levels for measuring timing of input signals. Also, transition times are measured between V_{IH} (min) and V_{IL} (max).
 8. Assumes that $t_{RCD} \leq t_{RCD}$ (max) and $t_{RAD} \leq t_{RAD}$ (max). If t_{RCD} or t_{RAD} is greater than the maximum recommended value shown in this table, t_{RAC} exceeds the value shown.
 9. Measured with a load circuit equivalent to 2TTL loads and 100 pF.
 10. Assumes that $t_{RCD} \geq t_{RCD}$ (max) and $t_{RCD} + t_{CAC}$ (max) $\geq t_{RAD} + t_{AA}$ (max).
 11. Assumes that $t_{RAD} \geq t_{RAD}$ (max) and $t_{RCD} + t_{CAC}$ (max) $\leq t_{RAD} + t_{AA}$ (max).
 12. Either t_{RCH} or t_{RRH} must be satisfied for a read cycles.
 13. t_{OFF} (max) and $t_{O EZ}$ (max) is define the time at which the outputs achieve the open circuit condition and are not referred to output voltage levels.
 14. t_{WCS} is not restrictive operating parameters. It is included in the data sheet as electrical characteristics only; if $t_{WCS} \geq t_{WCS}$ (min), the cycle is an early write cycle and the data out pin will remain open circuit (high impedance) throughout the entire cycle.
 15. These parameters are referred to \overline{CAS} leading edge in early write cycle.
 16. t_{RASP} defines \overline{RAS} pulse width in fast page mode cycles.
 17. Access time is determined by the longest among t_{AA} , t_{CAC} or t_{CPA} .
 18. Parity bit of this item must not use (DQ8, DQ17, DQ26, DQ35, DQ44, DQ53, DQ62, DQ71).
 19. XXX: H or L (H: V_{IH} (min) $\leq V_{IN} \leq V_{IH}$ (max), L: V_{IL} (min) $\leq V_{IN} \leq V_{IL}$ (max))
/////: Invalid Dout
When the address, clock and input pins are not described on timing waveforms, their pins must be applied V_{IH} or V_{IL} .

Timing Waveforms*19

Read Cycle

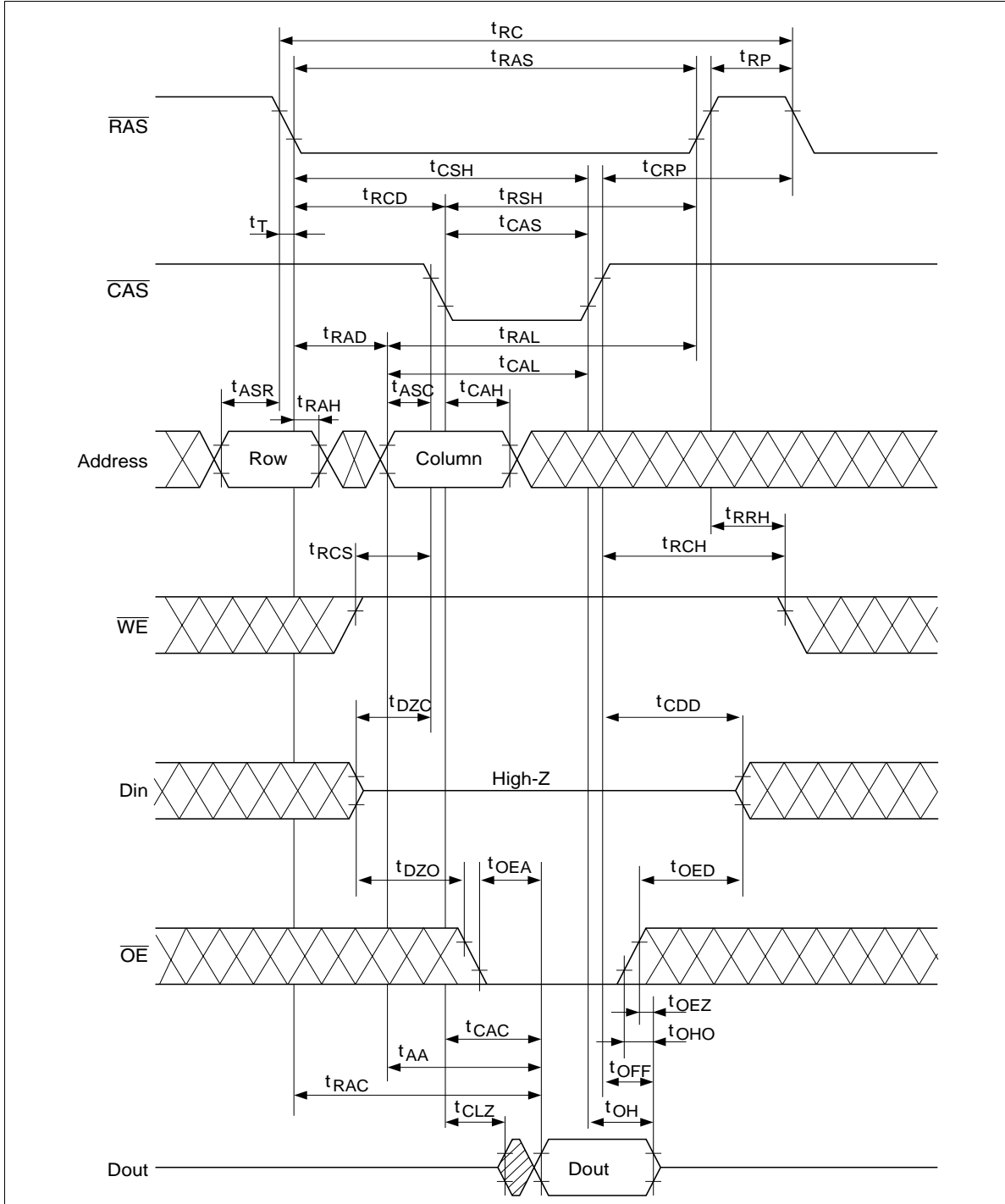

HB56D473EJ Series

Early Write Cycle

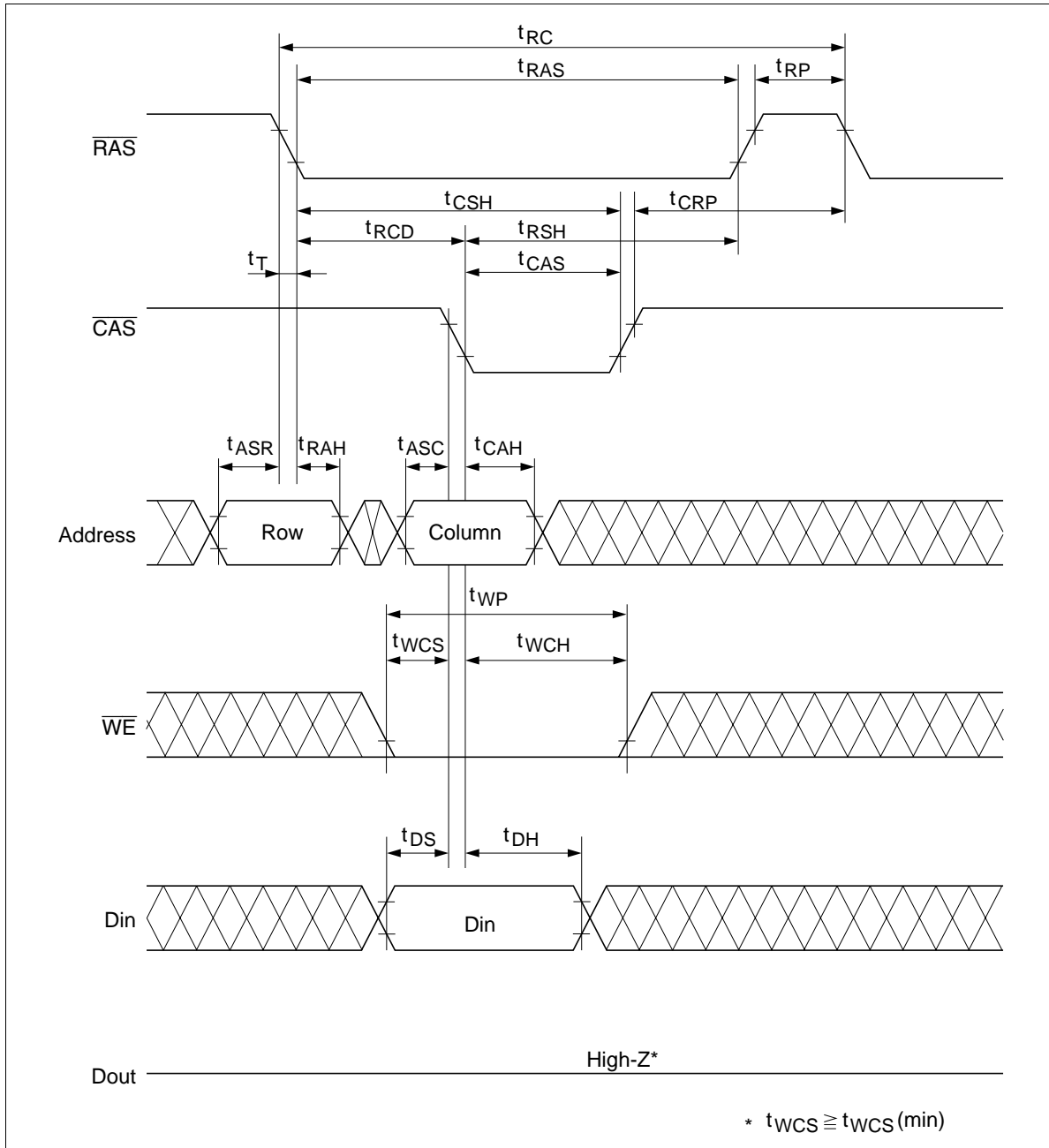

RAS-Only Refresh Cycle

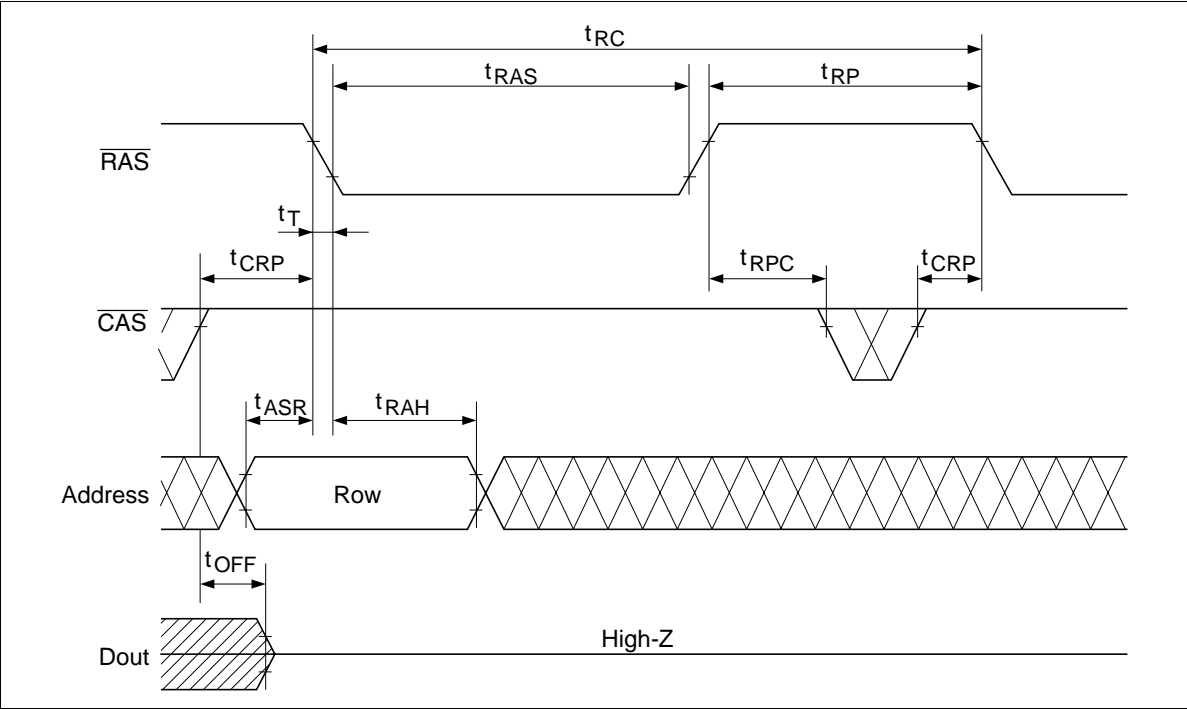

HB56D473EJ Series

$\overline{\text{CAS}}$ -Before- $\overline{\text{RAS}}$ Refresh Cycle

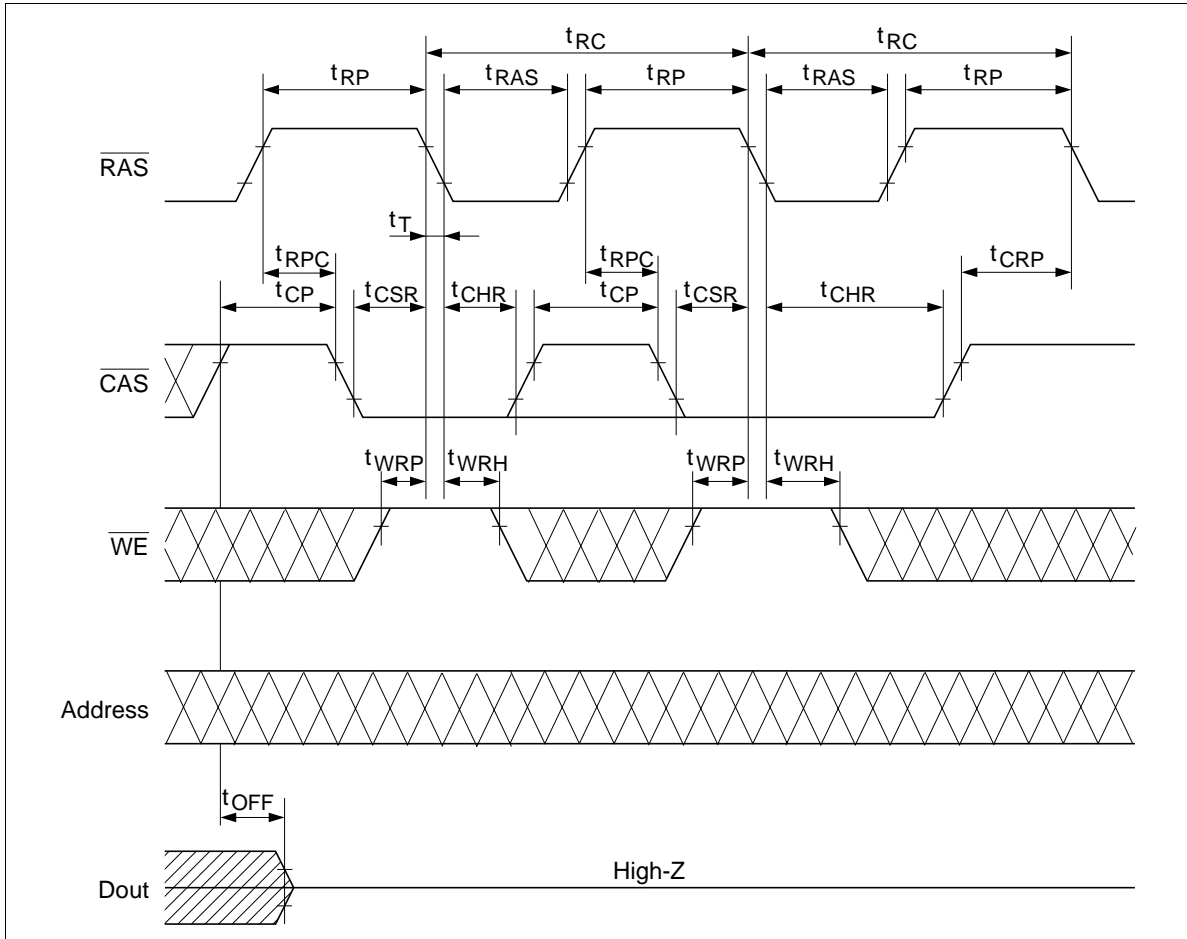

Fast Page Mode Read Cycle

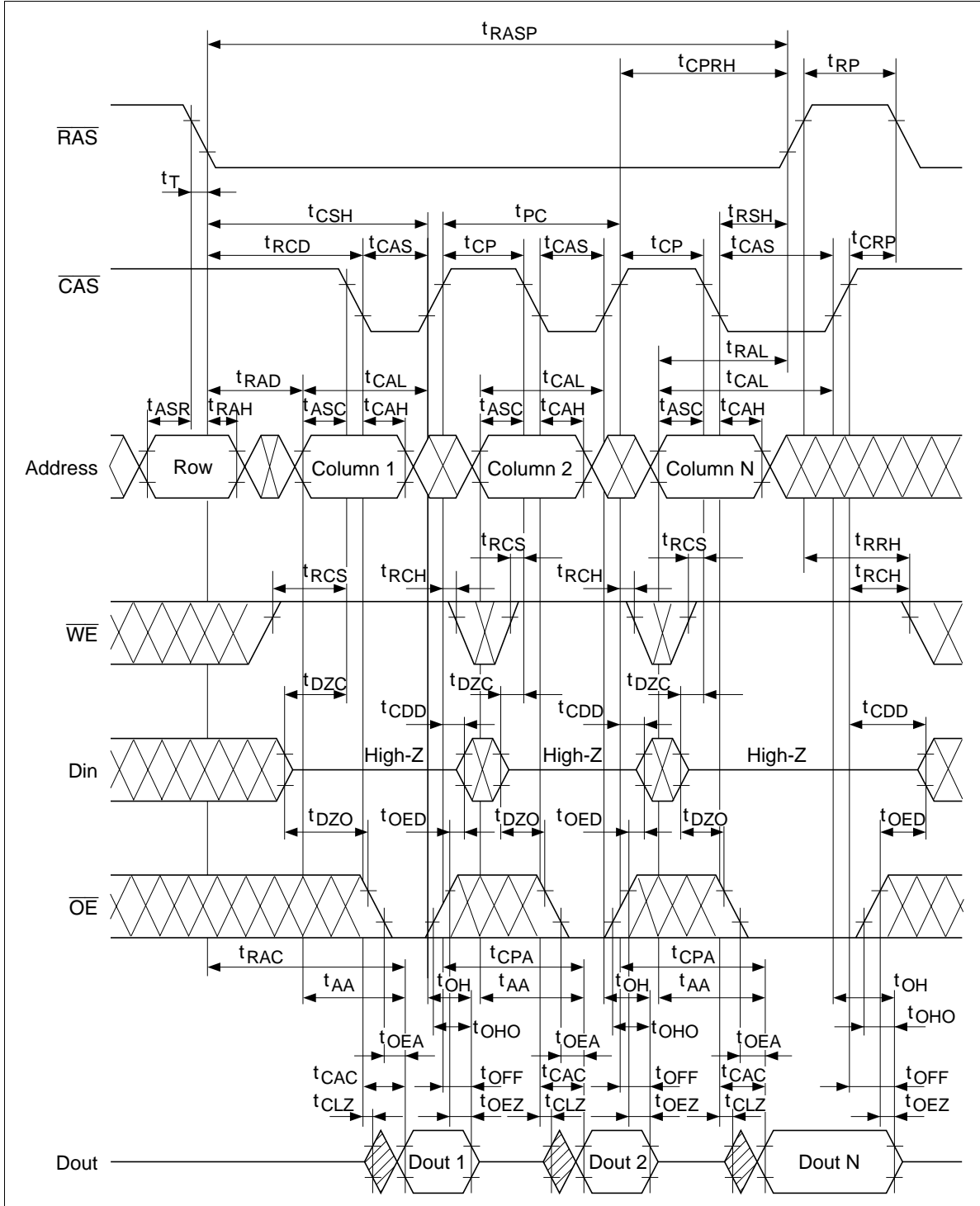

HB56D473EJ Series

Fast Page Mode Early Write Cycle

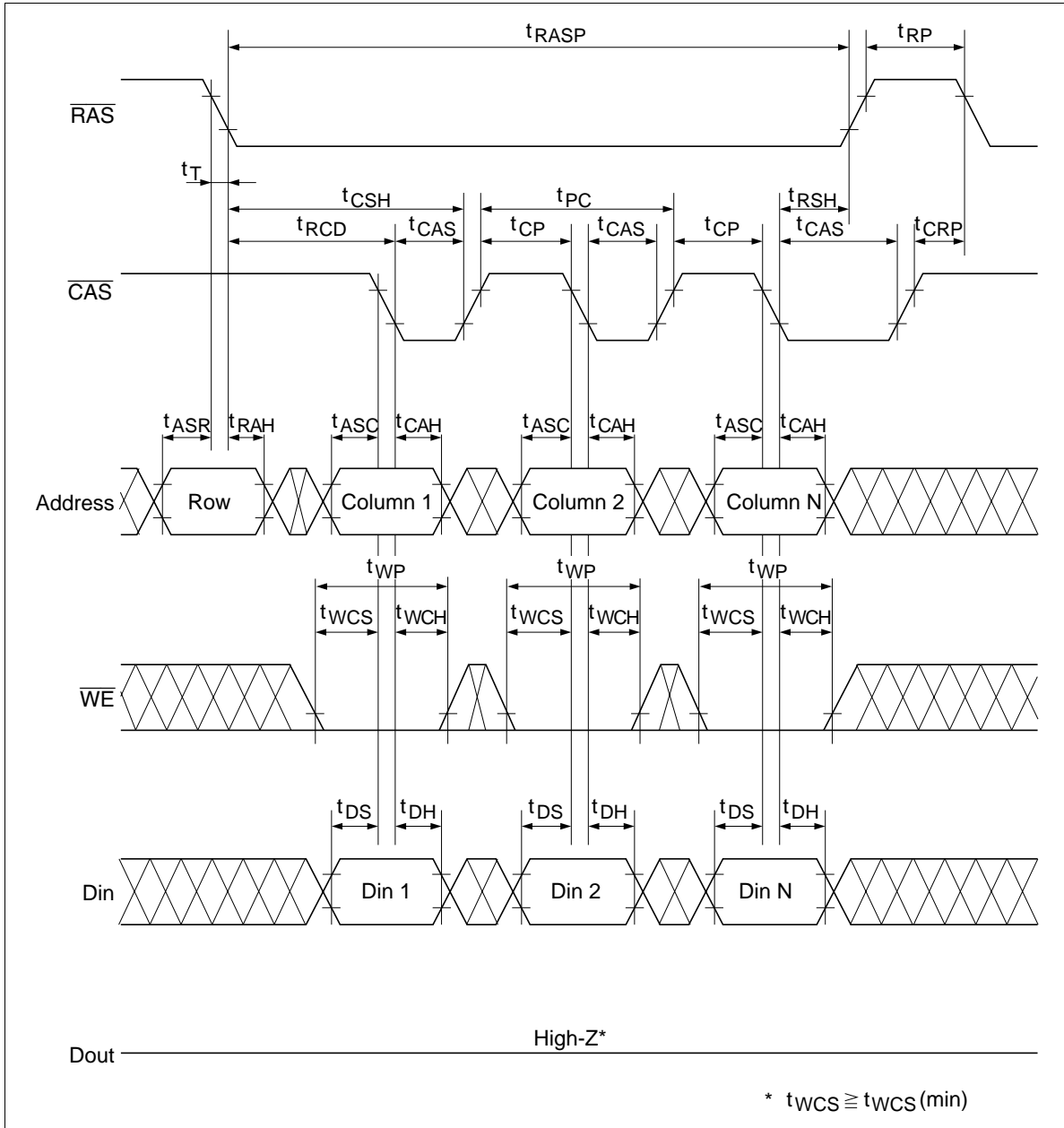

HB56D473EJ Series

Physical Outline

Unit: mm/inch

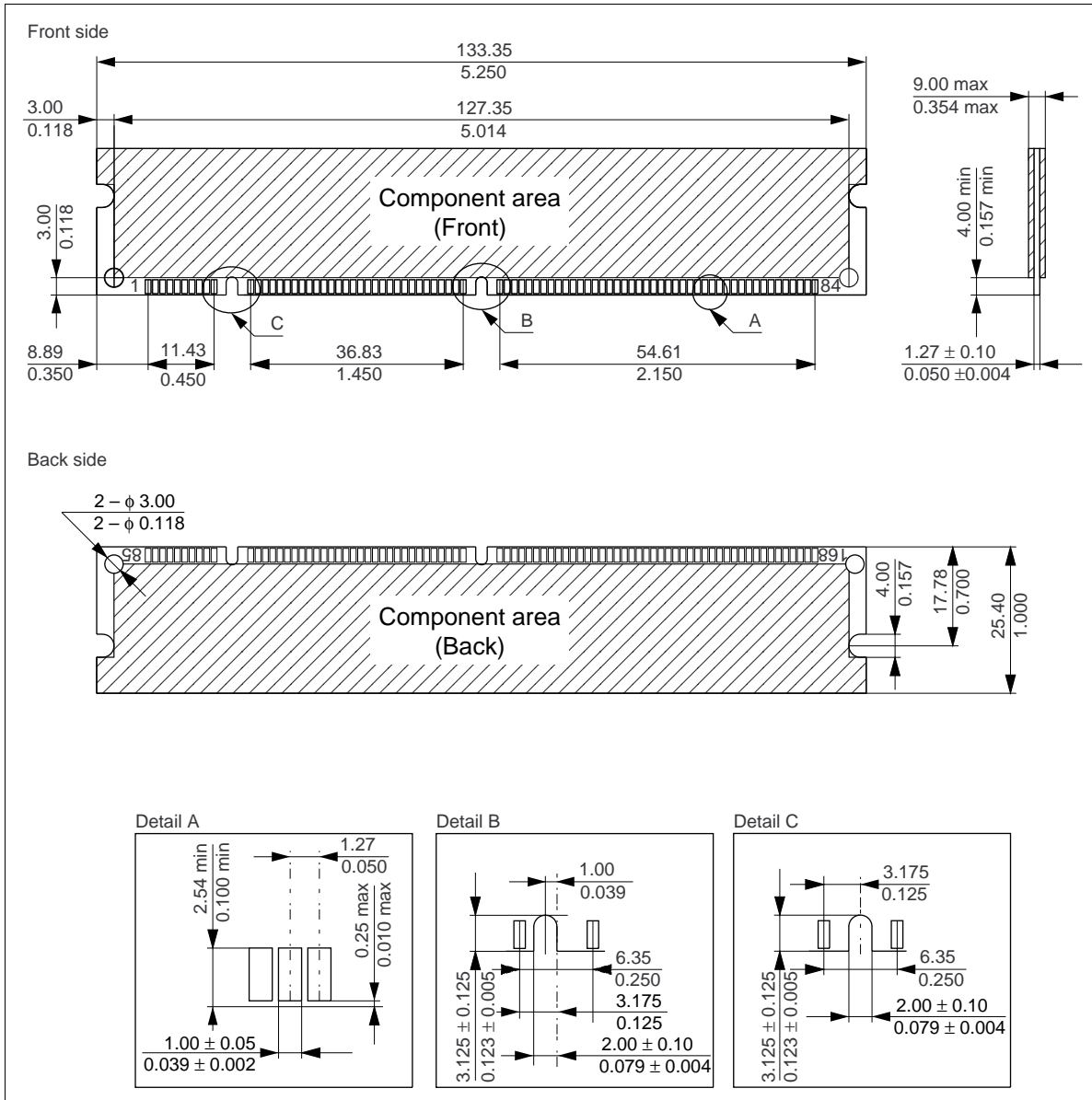

HB56D473EJ Series

When using this document, keep the following in mind:

1. This document may, wholly or partially, be subject to change without notice.
2. All rights are reserved: No one is permitted to reproduce or duplicate, in any form, the whole or part of this document without Hitachi's permission.
3. Hitachi will not be held responsible for any damage to the user that may result from accidents or any other reasons during operation of the user's unit according to this document.
4. Circuitry and other examples described herein are meant merely to indicate the characteristics and performance of Hitachi's semiconductor products. Hitachi assumes no responsibility for any intellectual property claims or other problems that may result from applications based on the examples described herein.
5. No license is granted by implication or otherwise under any patents or other rights of any third party or Hitachi, Ltd.
6. **MEDICAL APPLICATIONS:** Hitachi's products are not authorized for use in **MEDICAL APPLICATIONS** without the written consent of the appropriate officer of Hitachi's sales company. Such use includes, but is not limited to, use in life support systems. Buyers of Hitachi's products are requested to notify the relevant Hitachi sales offices when planning to use the products in **MEDICAL APPLICATIONS**.

HITACHI

Hitachi, Ltd.

Semiconductor & IC Div.
Nippon Bldg., 2-6-2, Ohte-machi, Chiyoda-ku, Tokyo 100, Japan
Tel: Tokyo (03) 3270-2111
Fax: (03) 3270-5109

For further information write to:

Hitachi America, Ltd.
Semiconductor & IC Div.
2000 Sierra Point Parkway
Brisbane, CA. 94005-1835
U S A
Tel: 415-589-8300
Fax: 415-583-4207

Hitachi Europe GmbH
Electronic Components Group
Continental Europe
Dornacher Straße 3
D-85622 Feldkirchen
München
Tel: 089-9 91 80-0
Fax: 089-9 29 30 00

Hitachi Europe Ltd.
Electronic Components Div.
Northern Europe Headquarters
Whitebrook Park
Lower Cookham Road
Maidenhead
Berkshire SL6 8YA
United Kingdom
Tel: 0628-585000
Fax: 0628-778322

Hitachi Asia Pte. Ltd.
16 Collyer Quay #20-00
Hitachi Tower
Singapore 0104
Tel: 535-2100
Fax: 535-1533

Hitachi Asia (Hong Kong) Ltd.
Unit 706, North Tower,
World Finance Centre,
Harbour City, Canton Road
Tsim Sha Tsui, Kowloon
Hong Kong
Tel: 27359218
Fax: 27306071

HB56D473EJ Series

Revision Record

Rev. Date	Contents of Modification	Drawn by	Approved by
1.0 Feb. 27, 1997	Initial issue		
