



HBAT54 Series

Description

Silicon Schottky Barrier Double Diodes

- HBAT54: Single Diode, also available as double diodes.
- HBAT54A: Common Anode.
- HBAT54C: Common Cathode.
- HBAT54S: Series Connected.

Features

These diodes feature very low turn-on voltage and fast switching. There is a PN junction guard ring against excessive voltage such as electronics attic discharges protects these devices.

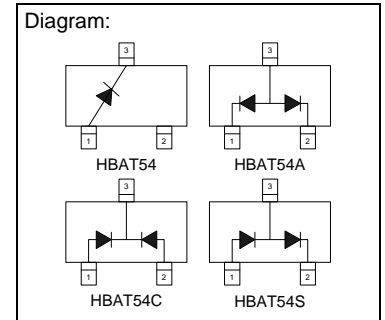
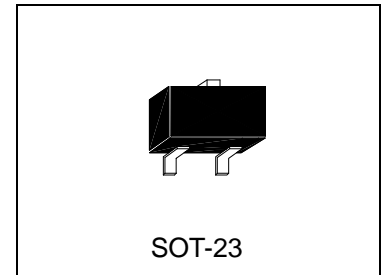

Absolute Maximum Ratings

- Maximum Temperatures
 - Storage Temperature -65~+125 °C
 - Junction Temperature +125 °C
- Maximum Power Dissipation
 - Total Power Dissipation (T_A=25°C) 230 mW
- Maximum Voltages and Currents (T_A=25°C)
 - Repetitive Peak Reverse Voltage 30 V
 - Forward Continuous Current 200 mA
 - Repetitive Peak Forward Current 300 mA
 - Surge Forward Current (tp<1s)..... 600 mA

Electrical Characteristics (T_A=25°C)

Characteristic	Symbol	Condition	Min.	Max.	Unit
Reverse breakdown Voltage	V _(BR)	I _R =10uA	30	-	V
Forward Voltage	V _{F(1)}	I _F =0.1mA	-	240	mV
	V _{F(2)}	I _F =1mA	-	320	mV
	V _{F(3)}	I _F =10mA	-	400	mV
	V _{F(4)}	I _F =30mA	-	500	mV
	V _{F(5)}	I _F =100mA	-	1000	mV
Reverse Current	I _R	V _R =25V	-	2.0	uA
Total Capacitance	C _T	V _R =1V, f=1MHz	-	10	pF
Reverse Recovery Time	T _{rr}	I _F =I _R =10mA, R _L =100Ω, measured at I _R =1mA	-	5	nS



Characteristics Curve

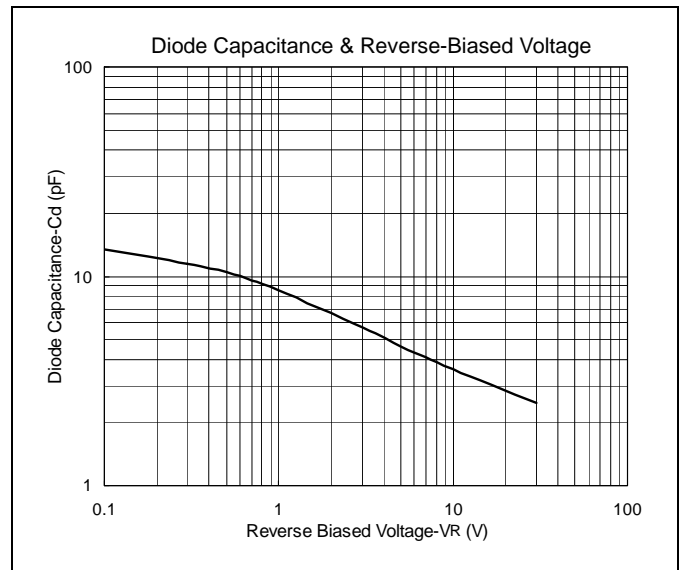
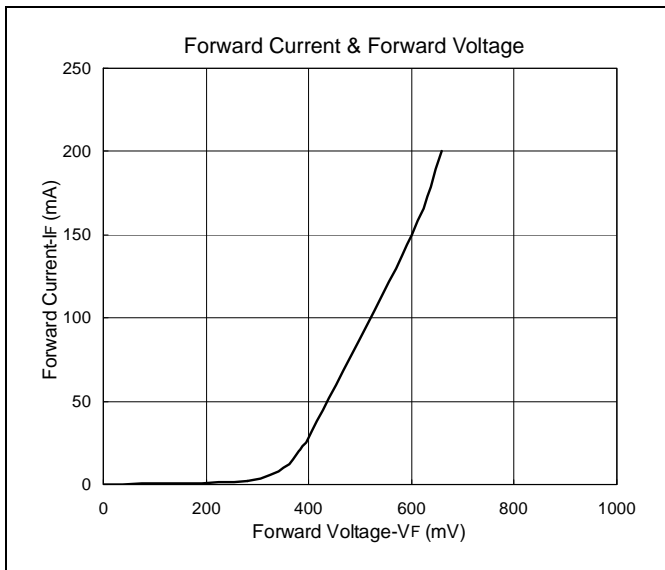



SOT-23 Dimension

BAT54

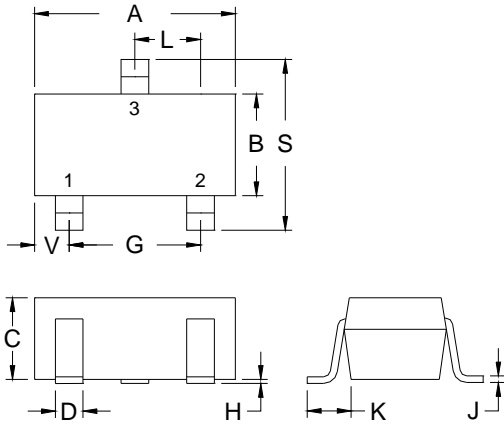

3-Lead SOT-23 Plastic
 Surface Mounted Package
 HSMC Package Code: N

Marking:

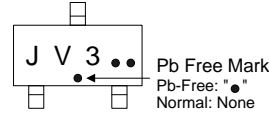

Note: Pb-free product can distinguish by the green label or the extra description on the right side of the label.

Pin Style: 1.Anode 2.Cathode
 3.Common Connection

- Material:
- Lead solder plating: Sn60/Pb40 (Normal), Sn/3.0Ag/0.5Cu or Pure-Tin (Pb-free)
 - Mold Compound: Epoxy resin family, flammability solid burning class: UL94V-0

DIM	Min.	Max.
A	2.80	3.04
B	1.20	1.60
C	0.89	1.30
D	0.30	0.50
G	1.70	2.30
H	0.013	0.10
J	0.085	0.177
K	0.32	0.67
L	0.85	1.15
S	2.10	2.75
V	0.25	0.65

*: Typical, Unit: mm

BAT54A

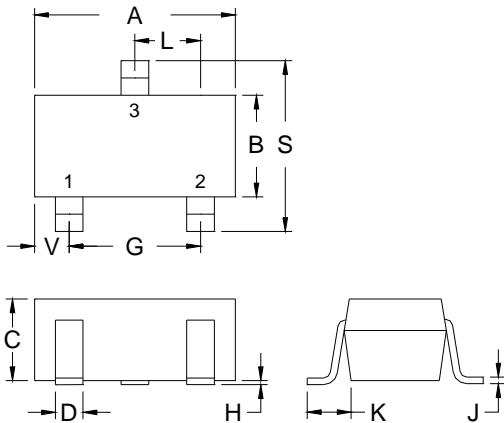

3-Lead SOT-23 Plastic
 Surface Mounted Package
 HSMC Package Code: N

Marking:

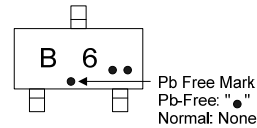

Note: Pb-free product can distinguish by the green label or the extra description on the right side of the label.

Pin Style: 1.Anode 2.Cathode
 3.Common Connection

- Material:
- Lead solder plating: Sn60/Pb40 (Normal), Sn/3.0Ag/0.5Cu or Pure-Tin (Pb-free)
 - Mold Compound: Epoxy resin family, flammability solid burning class: UL94V-0

DIM	Min.	Max.
A	2.80	3.04
B	1.20	1.60
C	0.89	1.30
D	0.30	0.50
G	1.70	2.30
H	0.013	0.10
J	0.085	0.177
K	0.32	0.67
L	0.85	1.15
S	2.10	2.75
V	0.25	0.65

*: Typical, Unit: mm



BAT54C

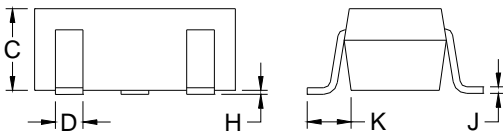
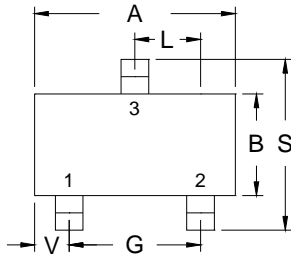

3-Lead SOT-23 Plastic
 Surface Mounted Package
 HSMC Package Code: N

Marking:

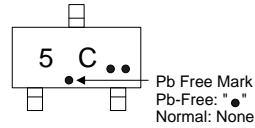

Note: Pb-free product can distinguish by the green label or the extra description on the right side of the label.

Pin Style: 1.Anode 2.Cathode
 3.Common Connection

Material:

- Lead solder plating: Sn60/Pb40 (Normal), Sn/3.0Ag/0.5Cu or Pure-Tin (Pb-free)
- Mold Compound: Epoxy resin family, flammability solid burning class: UL94V-0

DIM	Min.	Max.
A	2.80	3.04
B	1.20	1.60
C	0.89	1.30
D	0.30	0.50
G	1.70	2.30
H	0.013	0.10
J	0.085	0.177
K	0.32	0.67
L	0.85	1.15
S	2.10	2.75
V	0.25	0.65

*: Typical, Unit: mm

BAT54S

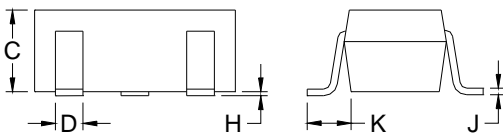
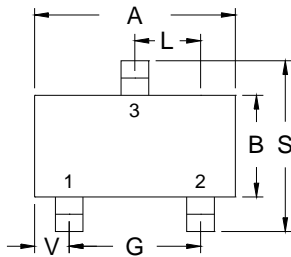

3-Lead SOT-23 Plastic
 Surface Mounted Package
 HSMC Package Code: N

Marking:

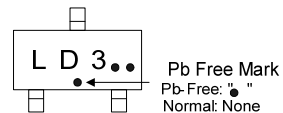

Note: Pb-free product can distinguish by the green label or the extra description on the right side of the label.

Pin Style: 1.Anode 2.Cathode
 3.Common Connection

Material:

- Lead solder plating: Sn60/Pb40 (Normal), Sn/3.0Ag/0.5Cu or Pure-Tin (Pb-free)
- Mold Compound: Epoxy resin family, flammability solid burning class: UL94V-0

DIM	Min.	Max.
A	2.80	3.04
B	1.20	1.60
C	0.89	1.30
D	0.30	0.50
G	1.70	2.30
H	0.013	0.10
J	0.085	0.177
K	0.32	0.67
L	0.85	1.15
S	2.10	2.75
V	0.25	0.65

*: Typical, Unit: mm

Important Notice:

- All rights are reserved. Reproduction in whole or in part is prohibited without the prior written approval of HSMC.
- HSMC reserves the right to make changes to its products without notice.
- **HSMC semiconductor products are not warranted to be suitable for use in Life-Support Applications, or systems.**
- HSMC assumes no liability for any consequence of customer product design, infringement of patents, or application assistance.

Head Office And Factory:

- **Head Office** (Hi-Sincerity Microelectronics Corp.): 10F.,No. 61, Sec. 2, Chung-Shan N. Rd. Taipei Taiwan R.O.C.
 Tel: 886-2-25212056 Fax: 886-2-25632712, 25368454
- **Factory 1:** No. 38, Kuang Fu S. Rd., Fu-Kou Hsin-Chu Industrial Park Hsin-Chu Taiwan. R.O.C
 Tel: 886-3-5983621~5 Fax: 886-3-5982931



Soldering Methods for HSMC's Products

1. Storage environment: Temperature=10°C~35°C Humidity=65%±15%
2. Reflow soldering of surface-mount devices

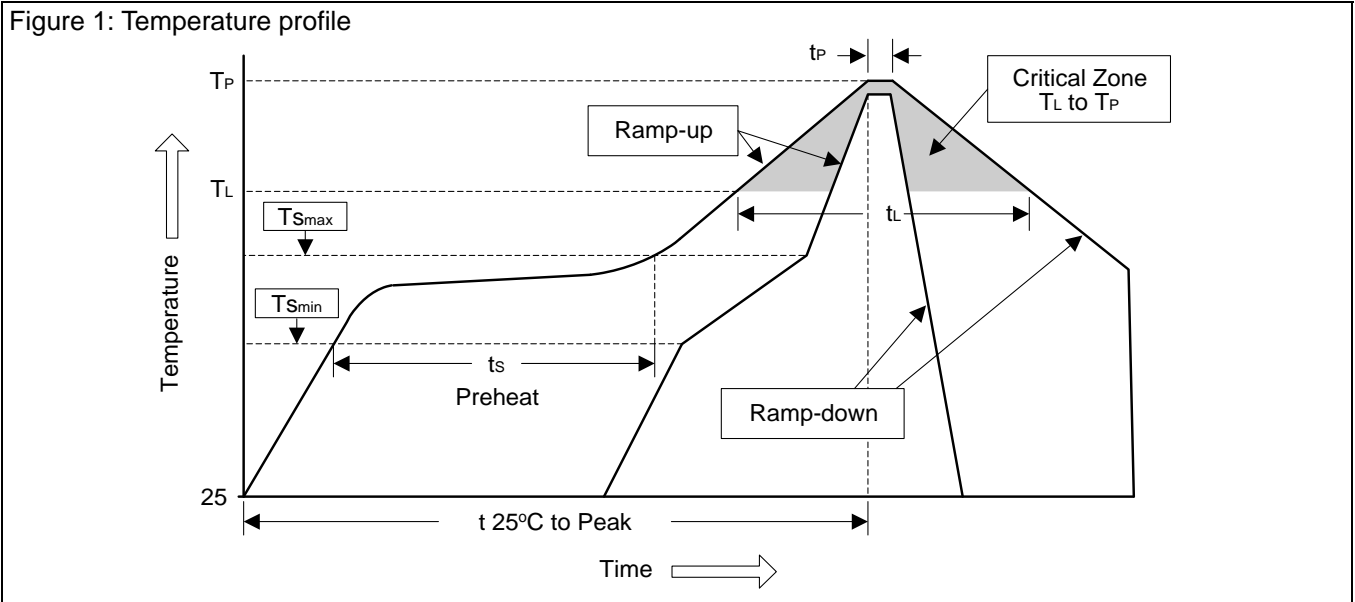

Profile Feature	Sn-Pb Eutectic Assembly	Pb-Free Assembly
Average ramp-up rate (T_L to T_P)	<3°C/sec	<3°C/sec
Preheat		
- Temperature Min (T_{Smin})	100°C	150°C
- Temperature Max (T_{Smax})	150°C	200°C
- Time (min to max) (t_s)	60~120 sec	60~180 sec
T_{Smax} to T_L		
- Ramp-up Rate	<3°C/sec	<3°C/sec
Time maintained above:		
- Temperature (T_L)	183°C	217°C
- Time (t_L)	60~150 sec	60~150 sec
Peak Temperature (T_P)	240°C +0/-5°C	260°C +0/-5°C
Time within 5°C of actual Peak Temperature (t_P)	10~30 sec	20~40 sec
Ramp-down Rate	<6°C/sec	<6°C/sec
Time 25°C to Peak Temperature	<6 minutes	<8 minutes

3. Flow (wave) soldering (solder dipping)

Products	Peak temperature	Dipping time
Pb devices.	245°C ±5°C	5sec ±1sec
Pb-Free devices.	260°C +0/-5°C	5sec ±1sec