

High Resolution Optical Reflective Sensor

Technical Data

HBCS-1100

Features

- Focused Emitter and Detector in a Single Package
- High Resolution—0.190 mm Spot Size
- 700 nm Visible Emitter
- Lens Filtered to Reject Ambient Light
- TO-5 Miniature Sealed Package
- Photodiode and Transistor Output
- Solid State Reliability

Description

The HBCS-1100 is a fully integrated module designed for optical reflective sensing. The module contains a 0.178 mm (0.007 in.) diameter 700 nm visible LED emitter and a

matched I.C. photodetector. A bifurcated aspheric lens is used to image the active areas of the emitter and the detector to a single spot 4.27 mm (0.168 in.) in front of the package. The reflected signal can be sensed directly from the photodiode or through an internal transistor that can be configured as a high gain amplifier.

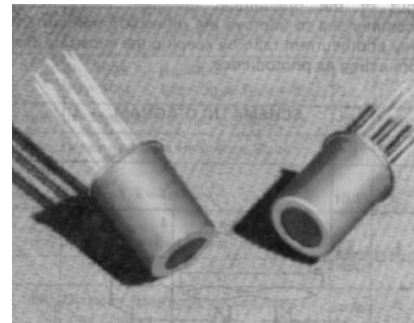

Applications

Applications include pattern recognition and verification, object sizing, optical limit switching, tachometry, textile thread counting and defect detection, dimensional monitoring, line locating, mark, and bar code scanning, and paper edge detection.

Mechanical Considerations

The HBCS-1100 is packaged in a high profile 8 pin TO-5 metal can with a glass window. The emitter and photodetector chips are mounted on the header at the base of the package. Positioned above these active elements is a bifurcated aspheric acrylic lens that focuses them to the same point.

Package Dimensions

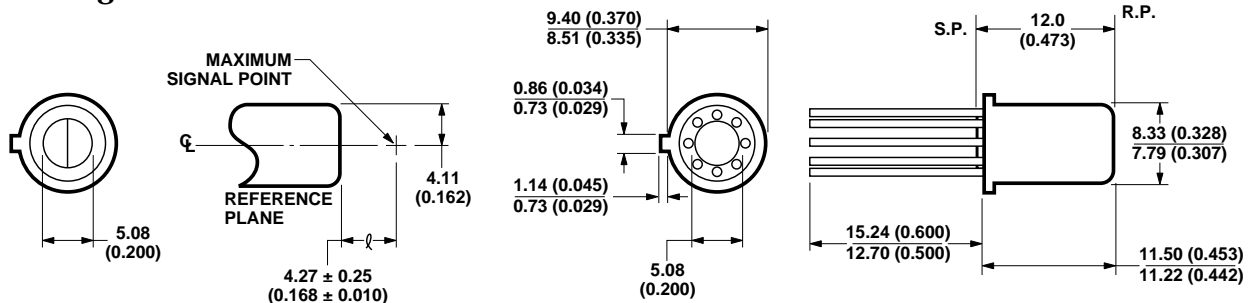

NOTES:

1. ALL DIMENSIONS IN MILLIMETERS AND (INCHES).
2. ALL UNTOLERANCED DIMENSIONS ARE FOR REFERENCE ONLY.
3. THE REFERENCE PLANE IS THE TOP SURFACE OF THE PACKAGE.
4. NICKEL CAN AND GOLD PLATED LEADS.
5. S.P. SEATING PLANE.
6. THE LEAD DIAMETER IS 0.45 mm (0.018 IN.) TYP.

The sensor can be rigidly secured by commercially available two piece TO-5 style heat sinks, such as Thermalloy 2205, or Aavid Engineering 3215. These fixtures provide a stable reference platform and their tapped mounting holes allow for ease of affixing this assembly to the circuit board.

Electrical Operation

The detector section of the sensor can be connected as a single photodiode or as a photodiode transistor amplifier. When photodiode operation is desired, it is recommended that the substrate diodes be defeated by connecting the collector of the

transistor to the positive potential of the power supply and shorting the base-emitter junction of the transistor. Figure 15 shows photocurrent being supplied from the anode of the photodiode to an inverting input of the operational amplifier. The circuit is recommended to improve the reflected photocurrent to stray photocurrent ratio by keeping the substrate diodes from acting as photodiodes.

The cathode of the 700 nm emitter is physically and electrically connected to the case-substrate of the device. Applications that require modulation or

switching of the LED should be designed to have the cathode connected to the electrical ground of the system. This insures minimum capacitive coupling of the switching transients through the substrate diodes to the detector amplifier section.

The HBCS-1100 detector also includes an NPN transistor which can be used to increase the output current of the sensor. A current feedback amplifier as shown in Figure 6 provides moderate current gain and bias point stability.

Schematic Diagram

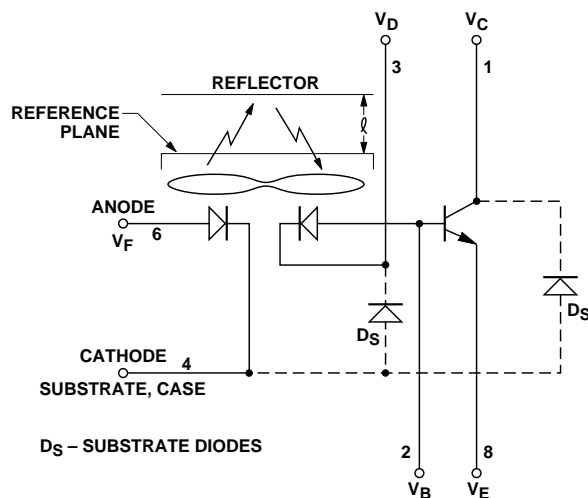

Connection Diagram

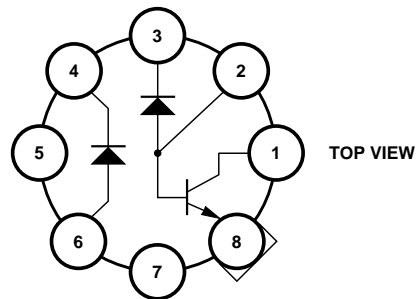

PIN	FUNCTION
1	TRANSISTOR COLLECTOR
2	TRANSISTOR BASE, PHOTODIODE ANODE
3	PHOTODIODE CATHODE
4	LED CATHODE, SUBSTRATE, CASE
5	NC
6	LED ANODE
7	NC
8	TRANSISTOR EMITTER

CAUTION: The small junction sizes inherent to the design of this bipolar component increase the component's susceptibility to damage from electrostatic discharge (ESD). It is advised that normal static precautions be taken in handling and assembly of this component to prevent damage and/or degradation which may be introduced by ESD.

Absolute Maximum Ratings at $T_A = 25^\circ\text{C}$

Parameter	Symbol	Min.	Max.	Units	Fig.	Notes
Storage Temperature	T_S	-40	+75	$^\circ\text{C}$		
Operating Temperature	T_A	-20	+70	$^\circ\text{C}$		
Lead Soldering Temperature 1.6 mm from Seating Plane			260 for 10 sec.	$^\circ\text{C}$		11
Average LED Forward Current	I_F		50	mA		2
Peak LED Forward Current	I_{FPK}		75	mA	1	1
Reverse LED Input Voltage	V_R		5	V		
Package Power Dissipation	P_P		120	mW		3
Collector Output Current	I_O		8	mA		
Supply and Output Voltage	V_D, V_C, V_E	-0.5	20	V		10
Transistor Base Current	I_B		5	mA		
Transistor Emitter Base Voltage	V_{EB}		0.5	V		

System Electrical/Optical Characteristics at $T_A = 25^\circ\text{C}$

Parameter	Symbol	Min.	Typ.	Max.	Units	Conditions	Fig.	Note
Total Photocurrent ($I_{PR} + I_{PS}$)	I_P			575	nA	$T_A = 20^\circ\text{C}$	2, 3	4
		150	250	375		$T_A = 25^\circ\text{C}$		
		80				$T_A = 70^\circ\text{C}$		
Reflected Photocurrent (I_{PR}) to Internal Stray Photocurrent (I_{PS})	$\frac{I_{PR}}{I_{PS}}$	4	8.5			$I_F = 35\text{ mA},$ $V_C = V_D = 5\text{ V}$	3	
Transistor DC Static Current Transfer Ratio	h_{FE}	50				$T_A = 20^\circ\text{C}$	4, 5	
		100	200			$T_A = 25^\circ\text{C}$		
Slew Rate			0.08		V/ μs	$R_L = 100\text{ K}, I_{PK} = 50\text{ mA},$ $R_F = 10\text{ M}, t_{ON} = 100\text{ }\mu\text{s},$ Rate = 1 kHz	6	
Image Diameter	d		0.17		mm	$I_F = 35\text{ mA},$ $\ell = 4.27\text{ mm (0.168 in.)}$	8, 10	8, 9
Maximum Signal Point	ℓ	4.01	4.27	4.52	mm	Measured from Reference Plane	9	
50% Modulation Transfer Function	MTF		2.5		I_{npr}/mm	$I_F = 35\text{ mA},$ $\ell = 4.27\text{ mm}$	10, 11	5, 7
Depth of Focus	$\Delta\ell$ FWHM		1.2		mm	50% of I_P at $\ell = 4.27\text{ mm}$	9	5
Effective Numerical Aperture	N.A.		0.3					
Image Location	D		0.51		mm	Diameter Reference to Centerline $\ell = 4.27\text{ mm}$		6
Thermal Resistance	Θ_{JC}		85		$^\circ\text{C}/\text{W}$			

Detector Electrical/Optical Characteristics at $T_A = 25^\circ\text{C}$

Parameter	Symbol	Min.	Typ.	Max.	Units	Conditions		Fig.	Note
Dark Current	I_{PD}		5	200	pA	$T_A = 25^\circ\text{C}$	$I_F = 0, V_D = 5\text{ V};$ Reflection = 0%		
				10	nA	$T_A = 70^\circ\text{C}$			
Capacitance	C_D		45		pF	$V_D = 0\text{ V}, I_P = 0, f = 1\text{ MHz}$			
Flux Responsivity	R_ϕ		0.22		A/W	$\lambda = 700\text{ nm}, V_D = 5\text{ V}$		12	
Detector Area	A_D		0.160		mm^2	Square, with Length = 0.4 mm/Side			

Emitter Electrical/Optical Characteristics at $T_A = 25^\circ\text{C}$

Parameter	Symbol	Min.	Typ.	Max.	Units	Conditions	Fig.	Note
Forward Voltage	V_F		1.6	1.8	V	$I_F = 35\text{ mA}$	13	
Reverse Breakdown Voltage	BV_R	5			V	$I_R = 100\text{ }\mu\text{A}$		
Radiant Flux	ϕ_E	5	9.0		μW	$I_F = 35\text{ mA},$ $\lambda = 700\text{ nm}$	14	
Peak Wavelength	λ_p	680	700	720	nm	$I_F = 35\text{ mA}$	14	
Thermal Resistance	Θ_{JC}		150		$^\circ\text{C/W}$			
Temperature Coefficient of V_F	$\Delta V_F/\Delta T$		-1.2		$\text{mV}/^\circ\text{C}$	$I_F = 35\text{ mA}$		

Transistor Electrical Characteristics at $T_A = 25^\circ\text{C}$

Parameter	Symbol	Min.	Typ.	Max.	Units	Conditions	Fig.	Note
Collector-Emitter Leakage	I_{CEO}		1		nA	$V_{CE} = 5\text{ V}$		
Base-Emitter Voltage	V_{BE}		0.6		V	$I_C = 10\text{ }\mu\text{A}, I_B = 70\text{ nA}$		
Collector-Emitter Saturation Voltage	$V_{CE(SAT)}$		0.4		V	$I_B = 1\text{ }\mu\text{A}, I_E = 10\text{ }\mu\text{A}$		
Collector-Base Capacitance	C_{CB}		0.3		pF	$f = 1\text{ MHz}, V_{CB} = 5\text{ V}$		
Base-Emitter Capacitance	C_{BE}		0.4		pF	$f = 1\text{ MHz}, V_{BE} = 0\text{ V}$		
Thermal Resistance	Θ_{JC}		200		$^\circ\text{C/W}$			

Notes:

- 300 μs pulse width, 1 kHz pulse rate.
- Derate Maximum Average Current linearly from 65°C by 6 $\text{mA}/^\circ\text{C}$.
- Without heat sinking from $T_A = 65^\circ\text{C}$, derate Maximum Average Power linearly by 12 $\text{mW}/^\circ\text{C}$.
- Measured from a reflector coated with a 99% reflective white paint (Kodak 6080) positioned 4.27 mm (0.168 in.) from the reference plane.
- Peak-to-Peak response to black and white bar patterns.
- Center of maximum signal point image lies within a circle of diameter D relative to the center line of the package. A second emitter image (through the detector lens) is also visible. This image does not affect normal operation.
- This measurement is made with the lens cusp parallel to the black-white transition.
- Image size is defined as the distance for the 10%-90% response as the sensor moves over an abrupt black-white edge.
- (+) indicates an increase in the distance from the reflector to the reference plane.
- All voltages referenced to Pin 4.
- CAUTION: The thermal constraints of the acrylic lens will not permit the use of conventional wave soldering procedures. The typical preheat and post cleaning temperatures and dwell times can subject the lens to thermal stresses beyond the absolute maximum ratings and can cause it to defocus.

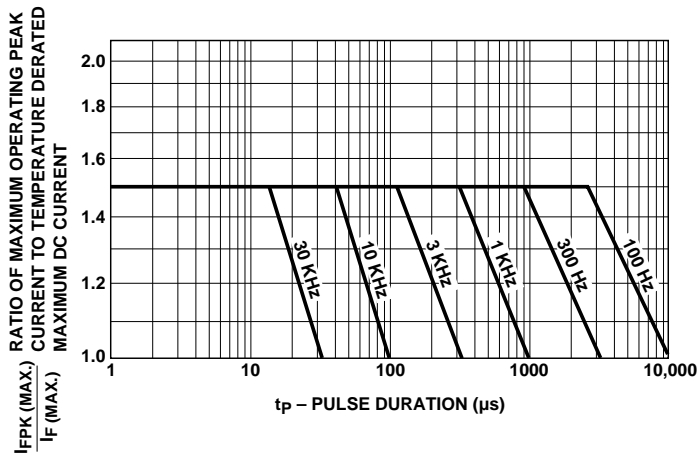

Figure 1. Maximum Tolerable Peak Current vs. Pulse Duration.

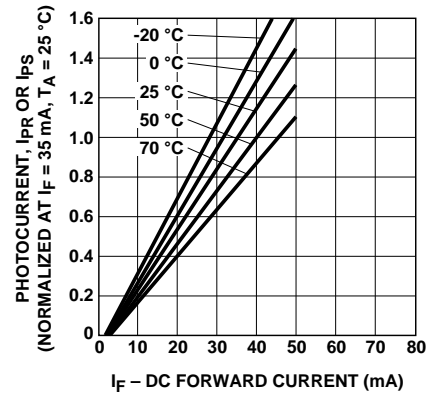
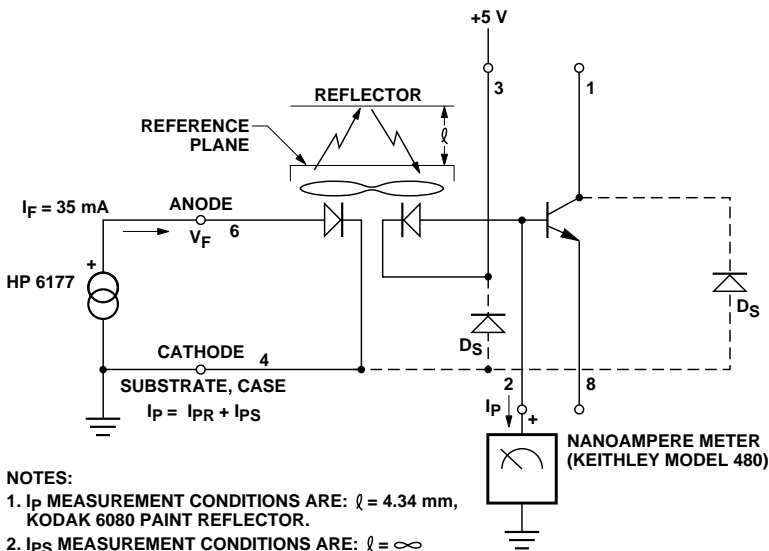

Figure 2. Relative Total Photocurrent vs. LED DC Forward Current.



- NOTES:
1. I_P MEASUREMENT CONDITIONS ARE: $l = 4.34$ mm, KODAK 6080 PAINT REFLECTOR.
 2. I_{PS} MEASUREMENT CONDITIONS ARE: $l = \infty$ A CAVITY WHOSE DEPTH IS MUCH GREATER THAN THE HBCS-1100 DEPTH OF FIELD.

Figure 3. I_P Test Circuit.

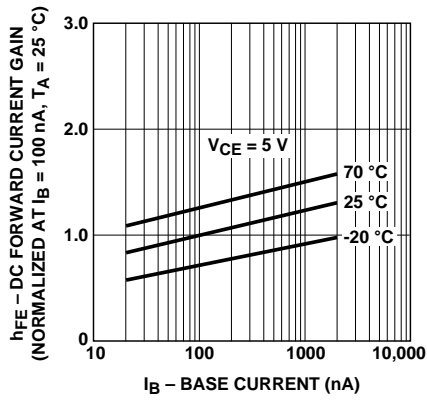

Figure 4. Normalized Transistor DC Forward Current Gain vs. Base Current at Temperature.

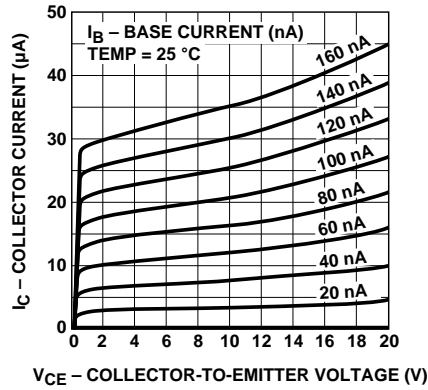

Figure 5. Common Emitter Collector Characteristics.

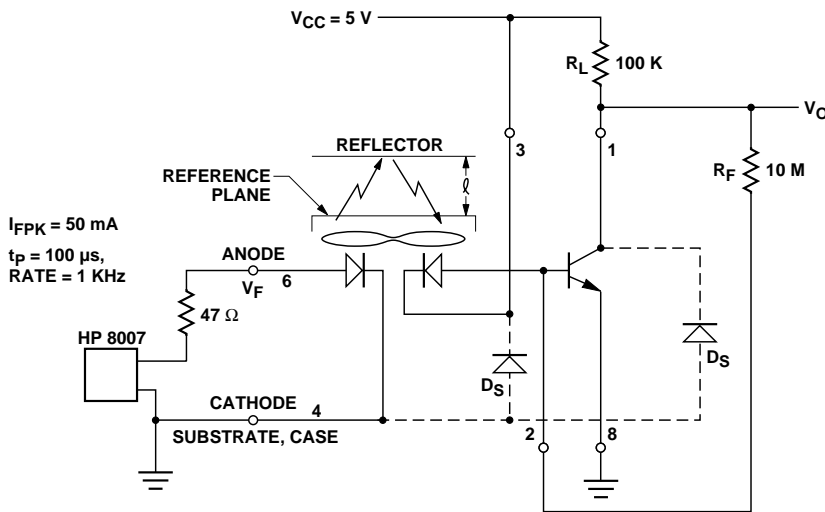

Figure 6. Slew Rate Measurement Circuit.

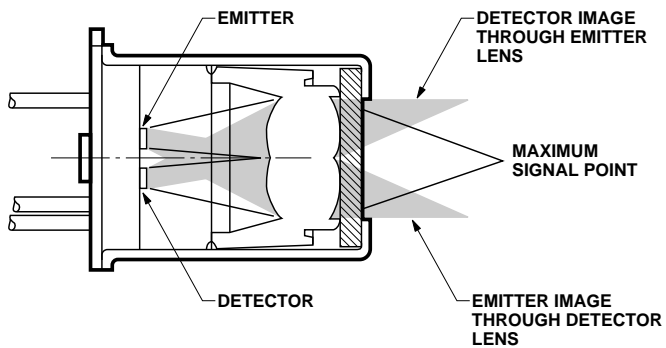

Figure 7. Image Location.

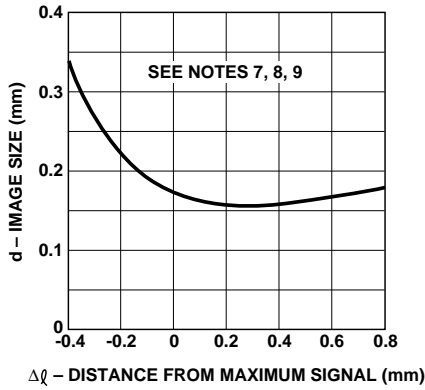

Figure 8. Image Size vs. Maximum Signal Point.

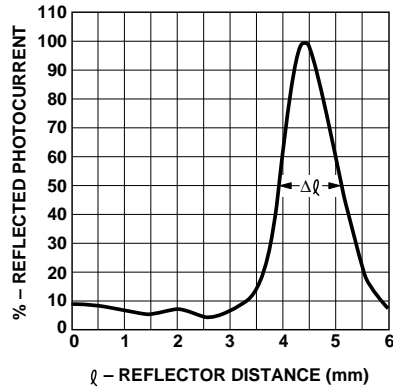

Figure 9. Reflector Distance vs. Percent Reflected Photocurrent.

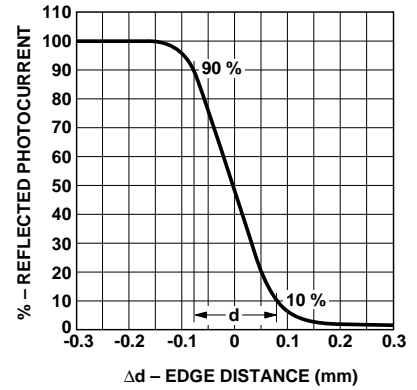

Figure 10. Step Edge Response.

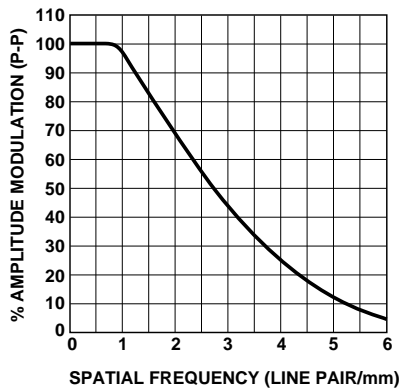

Figure 11. Modulation Transfer Function.

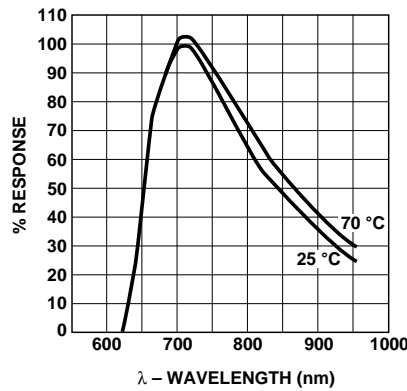

Figure 12. Detector Spectral Response.

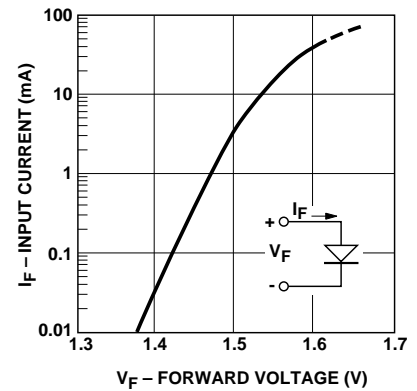

Figure 13. LED Forward Current vs. Forward Voltage Characteristics.

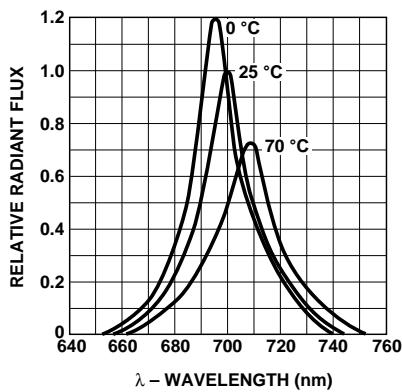

Figure 14. Relative Radiant Flux vs. Wavelength.

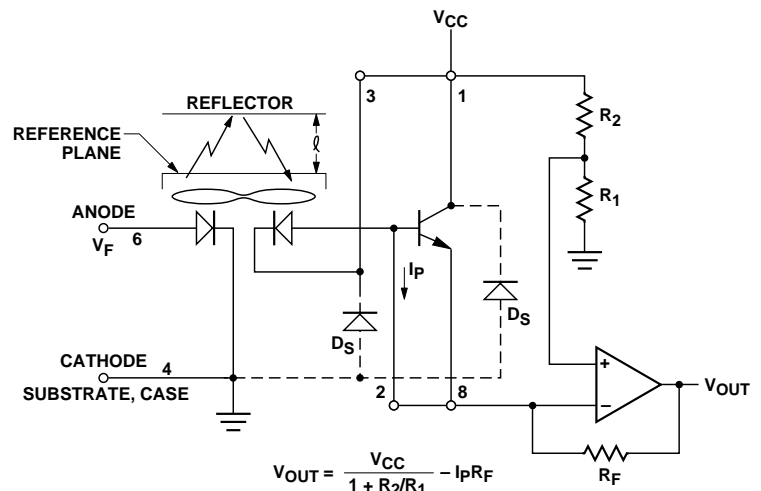

Figure 15. Photodiode Interconnection.