

# Schottky Barrier Rectifier

# HBR30100PT

### FEATURES

- Common Cathode Structure
- Low Power Loss,high Efficiency
- High Operating Junction Temperature
- Guarding for Overvoltage protection, High reliability
- 100% avalanche tested
- RoHS product
- Minimum Lot-to-Lot variations for robust device performance and reliable operation

### APPLICATIONS

- High Frequency switch power Supply
- Free wheeling diodes and polarity protection applications

### ABSOLUTE MAXIMUM RATINGS(Ta=25°C)

SYMBOL	PARAMETER	VALUE	UNIT
V <sub>RRM</sub> V <sub>RMS</sub> V <sub>R</sub>	Peak Repetitive Reverse Voltage RMS Voltage DC Blocking Voltage	100	V
I <sub>F(AV)</sub>	Average Rectified Forward Current (Per Leg) (Total)	15 30	A
I <sub>FSM</sub>	Nonrepetitive Peak Surge Current 8.3ms single half sine-wave superimposed on rated load conditions	275	A
T <sub>J</sub>	Junction Temperature	175	°C
T <sub>stg</sub>	Storage Temperature Range	-40~150	°C

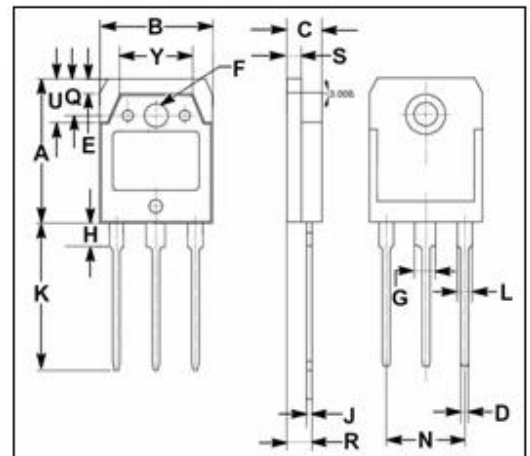
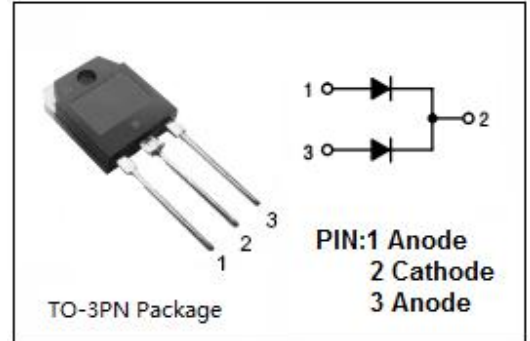

DIM	mm	
	MIN	MAX
A	19.60	20.30
B	15.50	15.70
C	4.70	4.90
D	0.90	1.10
E	1.90	2.10
F	3.40	3.60
G	2.90	3.20
H	3.20	3.40
J	0.595	0.605
K	19.80	20.70
L	1.90	2.20
N	10.89	10.91
Q	4.90	5.10
R	3.35	3.45
S	1.995	2.100
U	5.90	6.20
Y	9.90	10.10

**Schottky Barrier Rectifier****HBR30100PT****THERMAL CHARACTERISTICS**

SYMBOL	PARAMETER	MAX	UNIT
$R_{th\ j-c}$	Thermal Resistance, Junction to Case	2.0	$^{\circ}C/W$

**ELECTRICAL CHARACTERISTICS**

SYMBOL	PARAMETER	CONDITIONS	MAX	UNIT
$V_F$	Maximum Instantaneous Forward Voltage	$I_F = 15A ; T_j = 25^{\circ}C$	0.9	V
		$I_F = 15A ; T_j = 125^{\circ}C$	0.75	
$I_R$	Maximum Instantaneous Reverse Current	$V_R = V_{RWM} ; T_j = 25^{\circ}C$	30	$\mu A$
		$V_R = V_{RWM} ; T_j = 125^{\circ}C$	30	mA