

HC-SR04 Ultrasonic Sensor Module

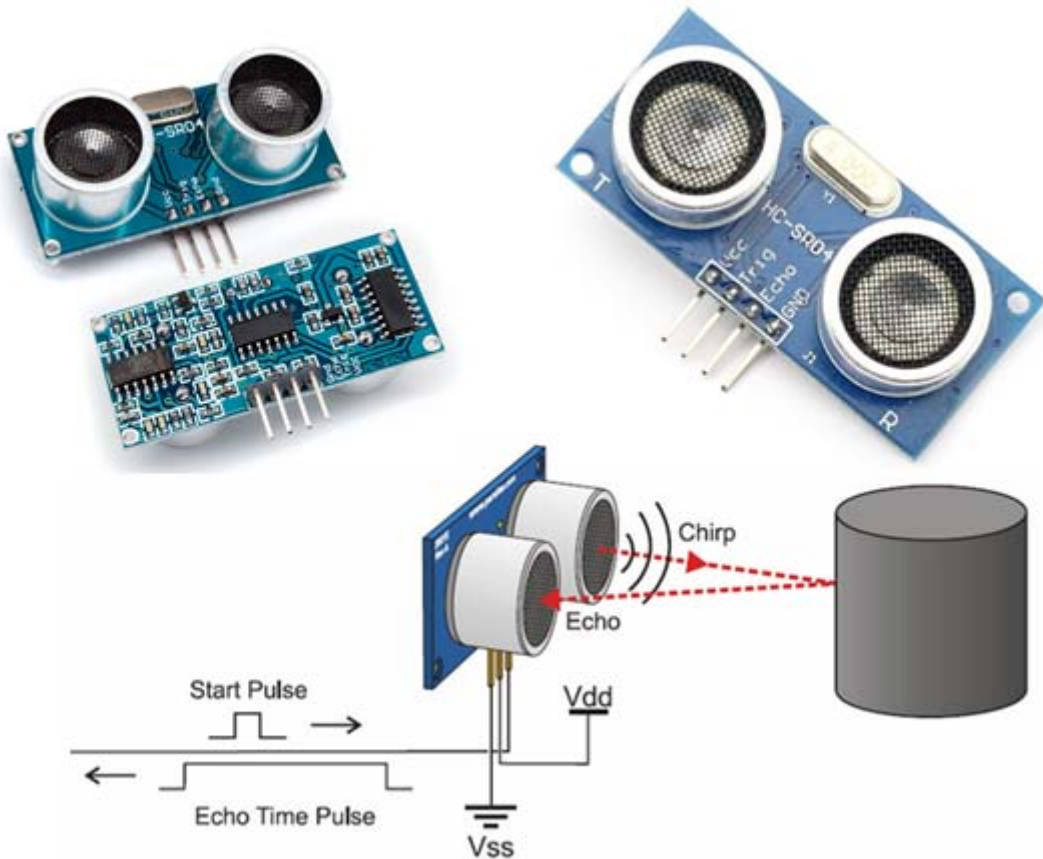

User Guide: Ultrasonic Sensor V1.0

Table of Contents

1.0 Introduction:.....	3
2.0: Module Specification	3
2.1: Sensor Element Construction.....	4
3.0: Ultrasonic Real Application	4
3.1 Car Parking Reverse Sensors	4
3.2: Liquid Level Detection.....	4
4.0: Pins Assignment and Dimension	5
4.1 Pin Assignment.....	5
4.2 Mechanical Dimension.....	5
4.3 Timing Diagram	6
5.0:HandsOn Technology Products Quality Commitments	7
5.1WARRANTY.....	7

1.0 Introduction:

Ultrasonic is an excellent way of figuring out what's in the immediate vicinity of your Arduino. The basics of using ultrasound are like this: you shoot out a sound, wait to hear it echo back, and if you have your timing right, you'll know if anything is out there and how far away it is. This is called echolocation and it's how bats and dolphins find objects in the dark and underwater, though they use lower frequencies than you can use with your Arduino. Figure-1 shows the working principle of ultrasonic ranging concept.

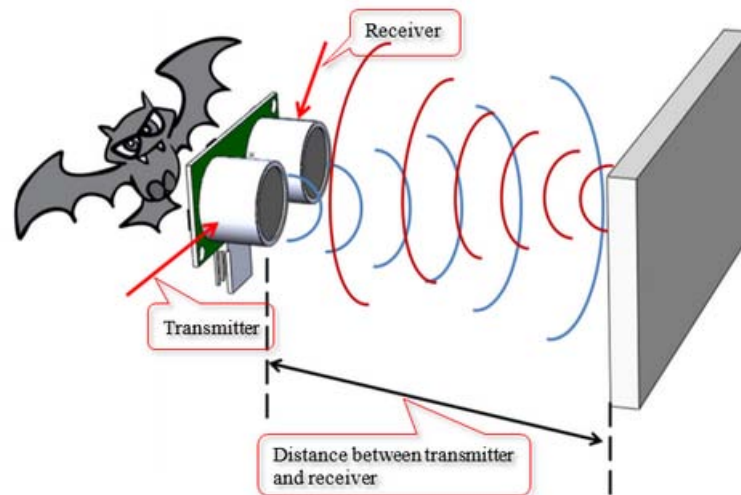

Figure-1

HC-SR04 Ultrasonic Sensor is a very affordable proximity/distance sensor that has been used mainly for object avoidance in various robotics projects. It has also been used in turret applications, water level sensing, and even as a parking sensor.

This module is the second generation of the popular HC-SR04 Low Cost Ultrasonic Sensor. Unlike the first generation HC-SR04 that can only operate between 4.8V~5V DC, this new version has wider input voltage range, allow it to work with controller operates on 3.3V. HC-SR04 ultrasonic sensor provides a very low-cost and easy method of distance measurement. It measures distance using sonar, an ultrasonic (well above human hearing) pulse (~40KHz) is transmitted from the unit and distance-to-target is determined by measuring the time required for the echo return. This sensor offers excellent range accuracy and stable readings in an easy-to-use package. An on board 2.54mm pitch pin header allows the sensor to be plugged into a solderless breadboard for easy prototyping.

2.0: Module Specification

Electrical Parameters	Value
Operating Voltage	3.3Vdc ~ 5Vdc
Quiescent Current	<2mA
Operating Current	15mA
Operating Frequency	40KHz
Operating Range	2cm ~ 400cm (1in ~ 13ft)
Sensitivity	-65dB min
Sound Pressure	112dB
Effective Angle	15°
Connector	4-pins header with 2.54mm pitch
Dimension	45mm x 20mm x 15mm
Weight	9g

2.1: Sensor Element Construction

Piezoelectric crystals are used for sensor elements. Piezoelectric crystals will oscillate at high frequencies when electric energy is applied to it. The Piezoelectric crystals will generate electrical signal when ultrasound wave hit the sensor surface in reverse.

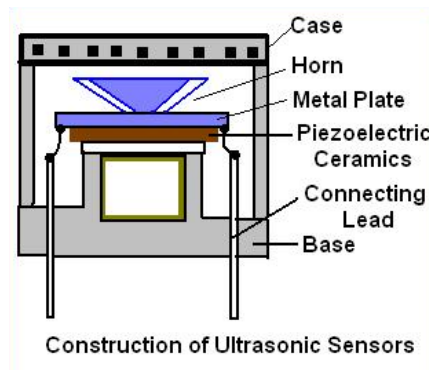

3.0: Ultrasonic Real Application

3.1 Car Parking Reverse Sensors

The main purpose is the distance range detection, which is widely used parking sensor for car. The sensor is used for calculating the distance, or direction of an object from the time it takes for a soundwave to travel to the object and echo back. The effective detective range is 0.3m ~ 3.0m. Refer to Figure-2.

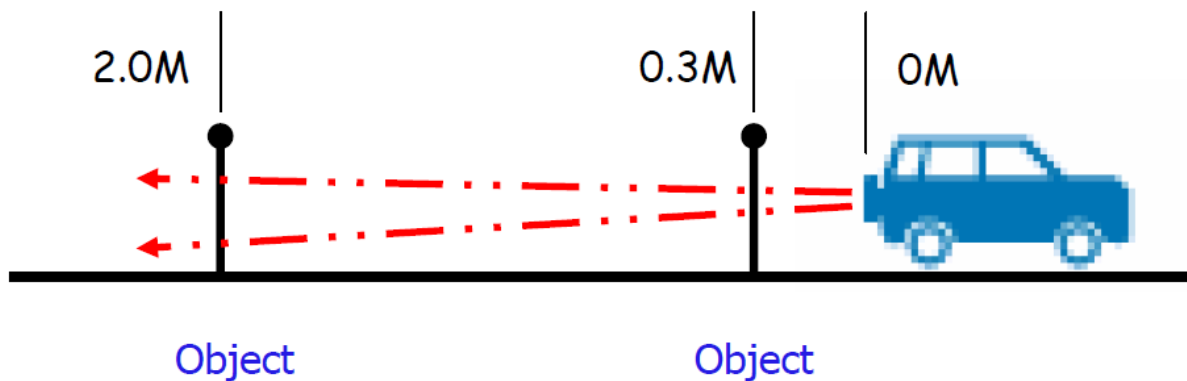

Figure-2.

3.2: Liquid Level Detection

Ultrasonic sensors are widely used for liquid level detection. In such cases, place a pipe on top of the sensor head as shown Figure-3. By detecting the liquid level inside the pipe, a wavy surface or bubbles which can disturb stable reading can be prevented.

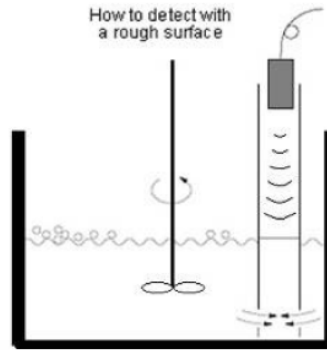
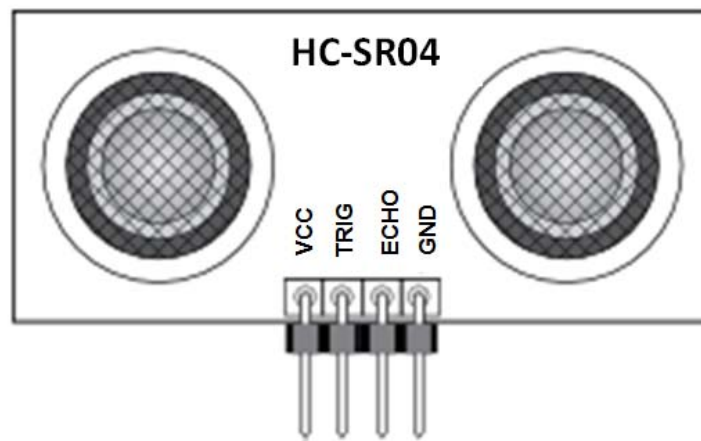

Figure-3.

4.0: Pins Assignment and Dimension

4.1 Pin Assignment



VCC	3.3v ~ 5V
TRIG	Triggering Input Pin. 10uS TTL Pulses
ECHO	TTL Logic Output Pin. Proportional to distance
GND	Ground Pin

4.2 Mechanical Dimension

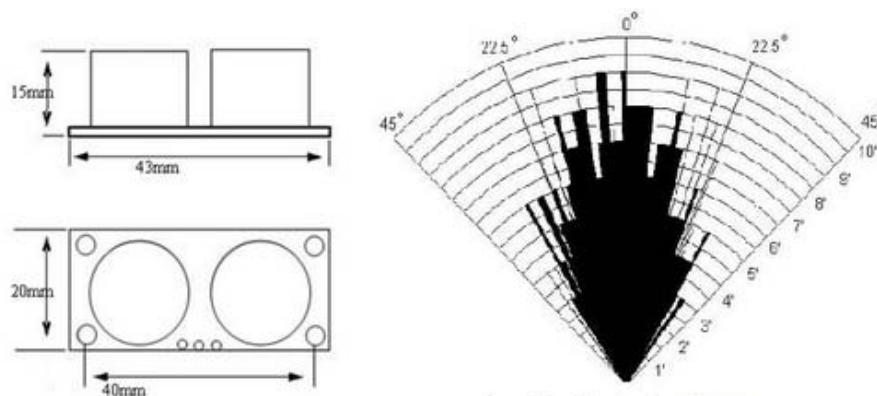

*Practical test of performance,
Best in 30 degree angle*

4.3 Timing Diagram

The timing diagram, Figure-4 is shown below. You only need to supply a short 10uS pulse to “Trigger Input” pin to start the ranging. The module will send out 8-cycles burst of ultrasound at 40KHz and raise its “Echo” pin, refer to Figure-5. The echo is a distance object that is pulse width and the range in proportion. You can calculate the range through the time interval between sending trigger signal and receiving echo signal.

Formula: $\mu\text{s} / 58 = \text{centimeters}$ or $\mu\text{s} / 148 = \text{inch}$

or: the range = high level time * sound velocity (340m/s) / 2;

Suggest to use over 60ms measurement cycle, in order to prevent trigger signal to the echo signal.

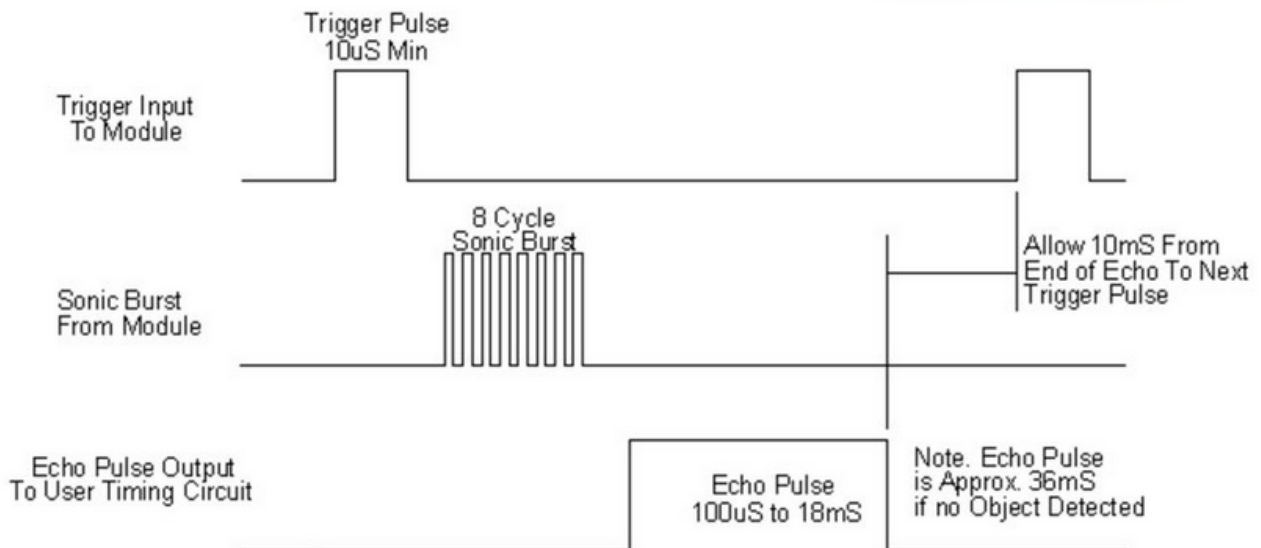

Figure-4: Timing Diagram

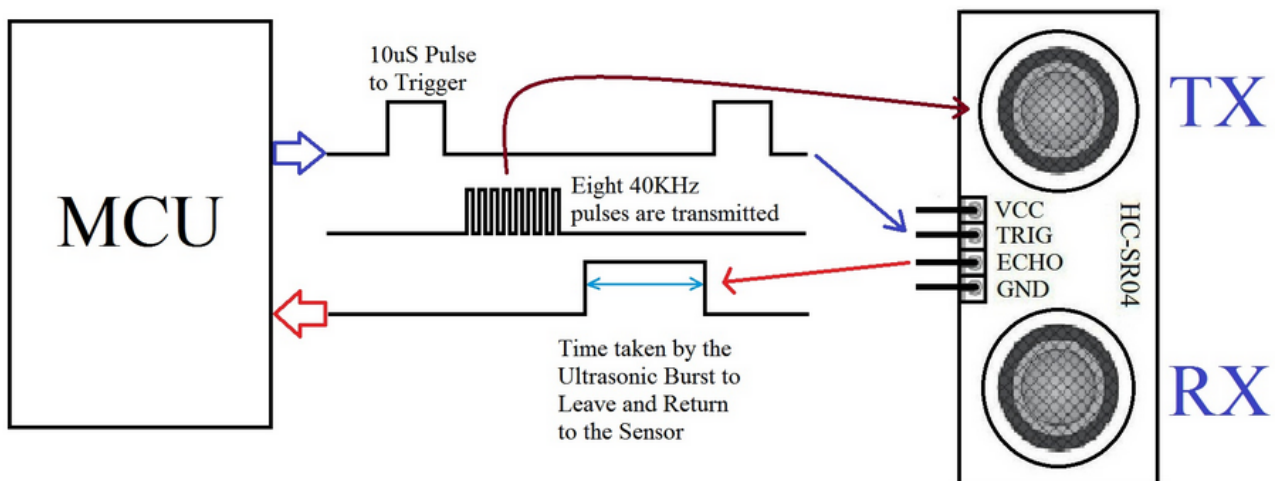

Figure-5: Microcontroller Interfacing

Please make sure the surface of object to be detected should have at least 0.5m² area for better performance.

5.0: HandsOn Technology Products Quality Commitments

HandsOn Technology wish to be perceived as simple and affordable by our customers. However the joy over a low price is never greater than the disappointment over poor quality products. All our parts are original genuine parts with proper data specifications from manufacturers. This is to ensure you always get the high quality genuine original part as stated in our products information.

5.1 WARRANTY

- Product warranty is valid for 6 months.
- Warranty only applies to manufacturing defect.
- Damaged caused by misuse is not cover under warranty.
- Warranty does not cover freight cost for both ways.

www.handsontec.com

Welcome to Handsontec Store



LCD+Keyboard Shield

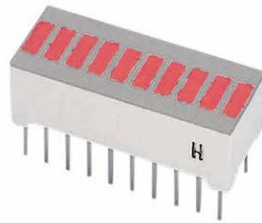

10-Segments LED Bar Display

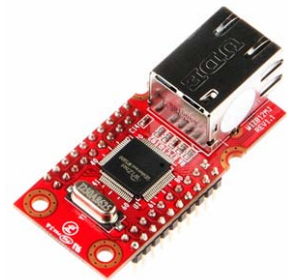

Ethernet Module



Arduino Uno



MicroSD Breakout Board

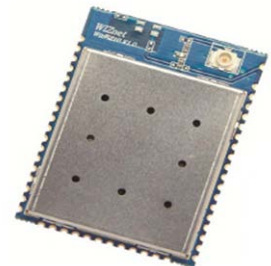

WiFi Module



20x4 LCD Display Module



Stepper Motor Driver

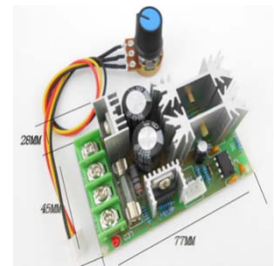

PWM Motor Speed Controller



www.handsontec.com

Breakout Board & Modules



www.handsontec.com

Integrated Circuits



www.handsontec.com

Discrete Parts



www.handsontec.com

Assembled Kits



www.handsontec.com

Connectors

This page is intentional left blank.