

Description

The HC2100A03 is a low profile, high performance 3dB hybrid coupler in a new easy to use, manufacturing friendly surface mount package. It is designed for UMTS & other 3G applications. The HC2100A03 is particularly for balanced power and low noise amplifiers, plus signal designed distribution and other applications where low insertion loss and tight amplitude and phase balance is required. It can be used in high power applications up to 105 Watts.

Parts have been subjected to rigorous qualification testing and they are manufactured using materials with coefficients of thermal expansion (CTE) compatible with common substrates such as FR4, G-10, RF-35, RO4350 and polyimide.

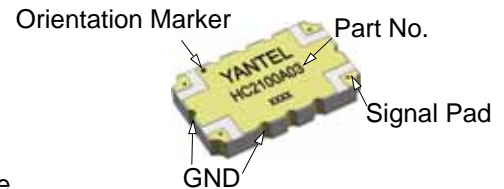

Features:

- 2000-2300 MHz
- UMT & 3G
- High Power
- Very Low Loss
- Tight Amplitude Balance
- High Isolation
- Low VSWR
- Good Repeatability
- CTE compatible with FR4, G-10, RF-35, RO4350B and polyimide
- Immersion gold, prevent surface oxidation & scratch
- RoHS Compliant
- Tape & Reel Package available

Electrical Specifications

Frequency	Isolation	Insertion Loss	VSWR	Amplitude Balance
<i>MHz</i>	<i>dB Min</i>	<i>dB Max</i>	<i>Max : 1</i>	<i>dB Max</i>
2000 - 2300	24	0.15	1.22	± 0.25
Phase Balance	Power	Operating Temp.		
<i>Degrees</i>	<i>Avg. CW Watts</i>	<i>°C</i>		
90 ± 2.0	105	-55 to +125		

Notes:

1. All the above data are based on specified demo board.
2. Insertion loss: Thru board loss has been removed.

Mechanical Outline

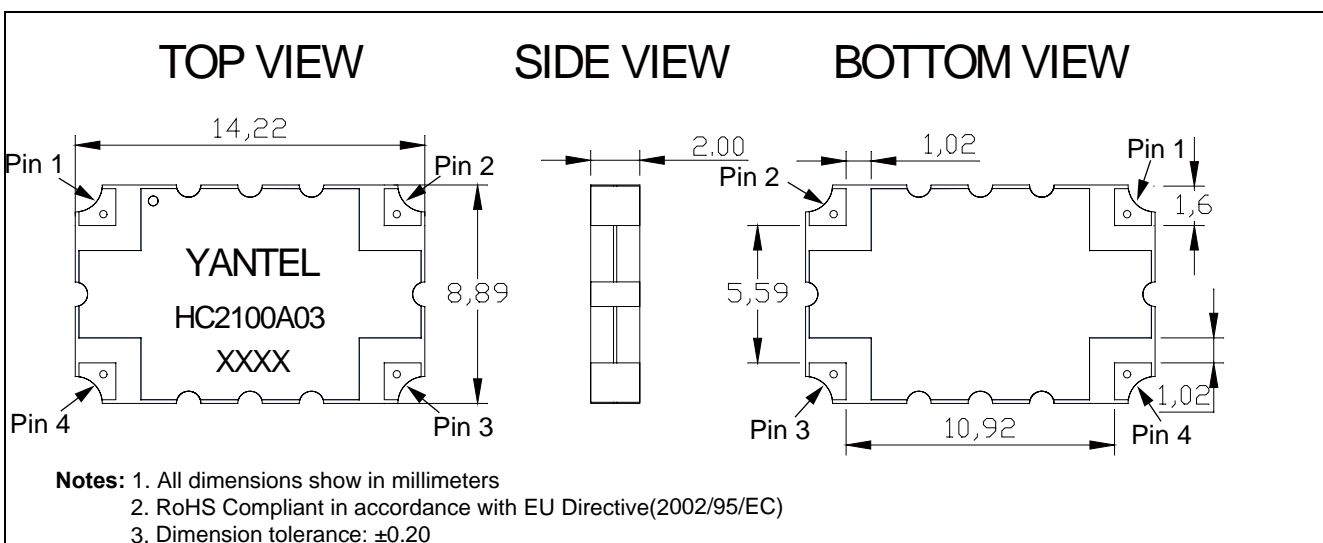

Yantel Corporation

Add : 3F, Building 3, Southern District 2 of Zhongguan Honghualing Industrial Park, Xili, Nanshan, Shenzhen, China
Tel : 86-755-8355-1886 Fax : 86-755-8355-2533

For detailed performance specs & shopping online see Yantel web site : www.yantel-corp.com

Hybrid Coupler Pin Configuration

The HC2100A03 has an orientation marker to denote Pin 1. Once port one has been identified the other ports are known automatically. Please see the chart below for clarification:

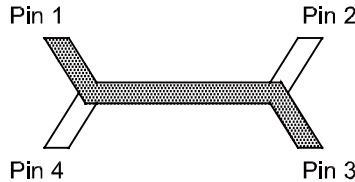

Configuration	Pin 1	Pin 2	Pin 3	Pin 4
Splitter	Input	Isolated	-3dB $\angle\theta - 90$	-3dB $\angle\theta$
Splitter	Isolated	Input	-3dB $\angle\theta$	-3dB $\angle\theta - 90$
Splitter	-3dB $\angle\theta - 90$	-3dB $\angle\theta$	Input	Isolated
Splitter	-3dB $\angle\theta$	-3dB $\angle\theta - 90$	Isolated	Input
*Combiner	$A \angle\theta - 90$	$A \angle\theta$	Isolated	Output
*Combiner	$A \angle\theta$	$A \angle\theta - 90$	Output	Isolated
*Combiner	Isolated	Output	$A \angle\theta - 90$	$A \angle\theta$
*Combiner	Output	Isolated	$A \angle\theta$	$A \angle\theta - 90$

*Note: "A" is the amplitude of the applied signals. When two quadrature signals with equal amplitudes are applied to the coupler as described in the table, they will combine at the output port. If the amplitudes are not equal, some of the applied energy will be directed to the isolated port.

Typical Performance Data (@25 °C)

Frequency (MHz)	Coupling (dB)	Transmission (dB)	Insertion Loss (dB)	Isolation (dB)	Amplitude Balance (dB)	Phase (degree)	Return Loss(dB)			
							S11	S22	S33	S44
2000	-3.20	-2.96	-0.07	-30.82	-0.24	89.47	-25.08	-27.58	-27.38	-31.36
2015	-3.17	-2.96	-0.05	-30.41	-0.21	89.52	-25.21	-26.76	-27.11	-30.55
2030	-3.17	-2.98	-0.06	-30.12	-0.19	89.64	-25.32	-27.26	-27.25	-29.54
2045	-3.18	-3.01	-0.08	-30.36	-0.17	89.54	-25.31	-28.09	-28.04	-28.99
2060	-3.19	-3.01	-0.09	-30.44	-0.18	89.45	-25.14	-28.92	-29.26	-29.14
2075	-3.18	-2.99	-0.07	-30.76	-0.19	89.41	-25.03	-29.68	-30.08	-29.97
2090	-3.18	-2.97	-0.06	-31.00	-0.21	89.55	-25.11	-29.68	-29.73	-30.49
2105	-3.17	-2.97	-0.06	-30.98	-0.20	89.74	-25.25	-29.24	-29.00	-30.30
2120	-3.17	-2.99	-0.07	-30.95	-0.18	89.63	-25.42	-28.81	-28.50	-29.51
2135	-3.17	-3.00	-0.07	-30.97	-0.17	89.58	-25.45	-28.78	-28.57	-28.48
2150	-3.18	-3.01	-0.08	-31.12	-0.17	89.62	-25.50	-29.19	-29.11	-28.09
2165	-3.18	-2.99	-0.07	-31.23	-0.19	89.61	-25.45	-29.77	-30.20	-28.37
2180	-3.17	-2.98	-0.06	-31.25	-0.19	89.58	-25.50	-30.75	-31.31	-29.19
2195	-3.18	-3.00	-0.08	-31.21	-0.18	89.66	-25.45	-30.74	-30.98	-29.92
2210	-3.19	-3.02	-0.09	-31.11	-0.17	89.70	-25.52	-29.64	-29.66	-30.02
2225	-3.17	-3.00	-0.07	-31.12	-0.17	89.70	-25.60	-28.83	-28.79	-29.03
2240	-3.17	-2.99	-0.07	-31.10	-0.18	89.76	-25.86	-28.83	-28.80	-28.09
2255	-3.17	-3.00	-0.07	-31.18	-0.17	89.87	-26.04	-29.52	-29.60	-27.62
2270	-3.18	-3.01	-0.08	-31.18	-0.17	89.80	-26.10	-31.16	-31.06	-27.95
2285	-3.20	-3.02	-0.10	-30.97	-0.18	89.56	-26.17	-32.19	-31.97	-29.05
2300	-3.23	-3.02	-0.11	-31.07	-0.21	89.48	-26.34	-31.13	-31.48	-30.27

Yantel Corporation

Add : 3F, Building 3, Southern District 2 of Zhongguan Honghualing Industrial Park, Xili, Nanshan, Shenzhen, China
Tel : 86-755-8355-1886 Fax : 86-755-8355-2533

For detailed performance specs & shopping online see Yantel web site : www.yantel-corp.com

Power Derating Curves

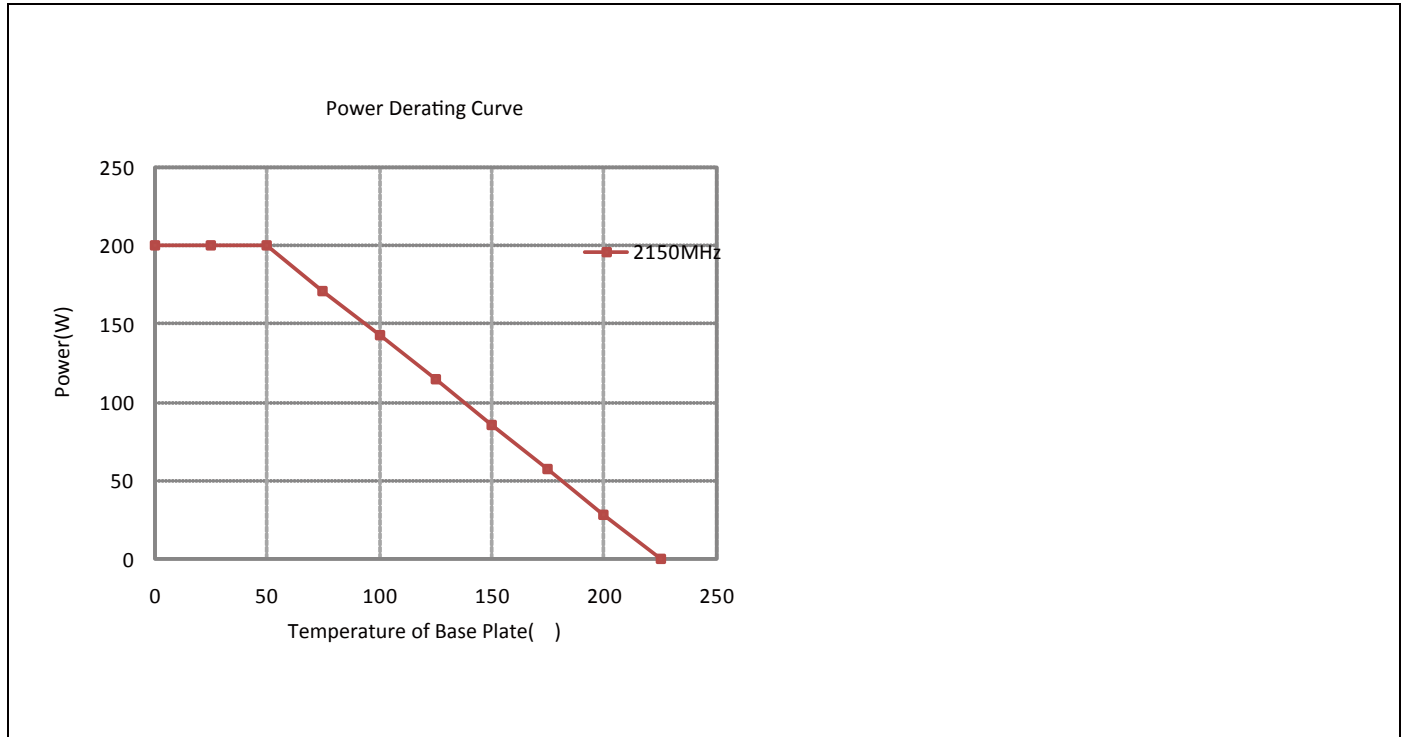

Power Derating:

As the mounting interface temperature approaches the maximum continuous operating temperature, the power handling decreases to zero.

Yantel Corporation

Add : 3F, Building 3, Southern District 2 of Zhongguan Honghualing Industrial Park, Xili, Nanshan, Shenzhen, China
Tel : 86-755-8355-1886 Fax : 86-755-8355-2533

For detailed performance specs & shopping online see Yantel web site : www.yantel-corp.com

Typical Performance (-55°C, 25°C, 95°C, 125°C: 2000-2300 MHz)

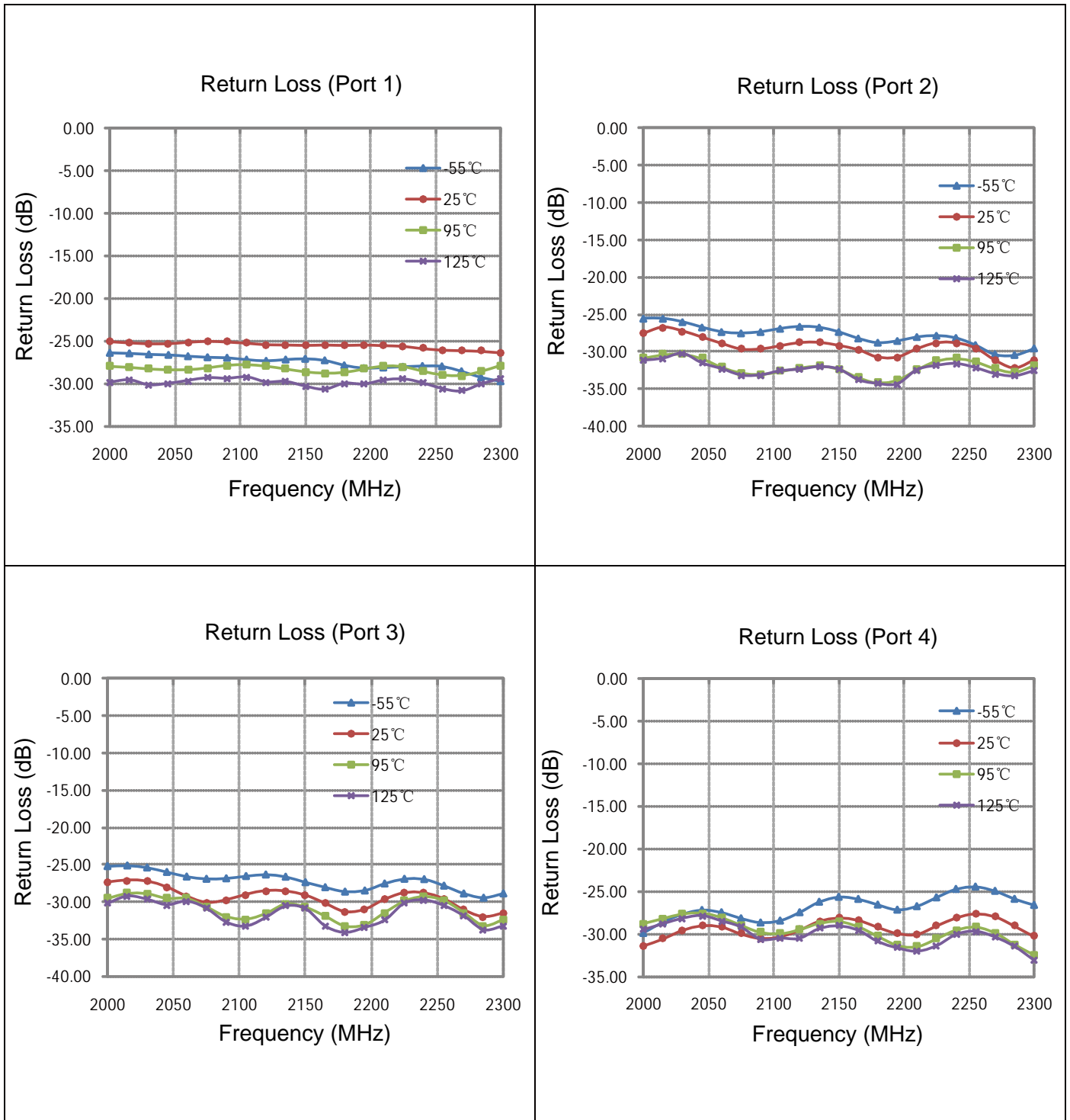

Yantel Corporation

Add : 3F, Building 3, Southern District 2 of Zhongguan Honghualing Industrial Park, Xili, Nanshan, Shenzhen, China
 Tel : 86-755-8355-1886 Fax : 86-755-8355-2533

For detailed performance specs & shopping online see Yantel web site : www.yantel-corp.com

Typical Performance (-55°C, 25°C, 95°C, 125°C: 2000-2300 MHz)

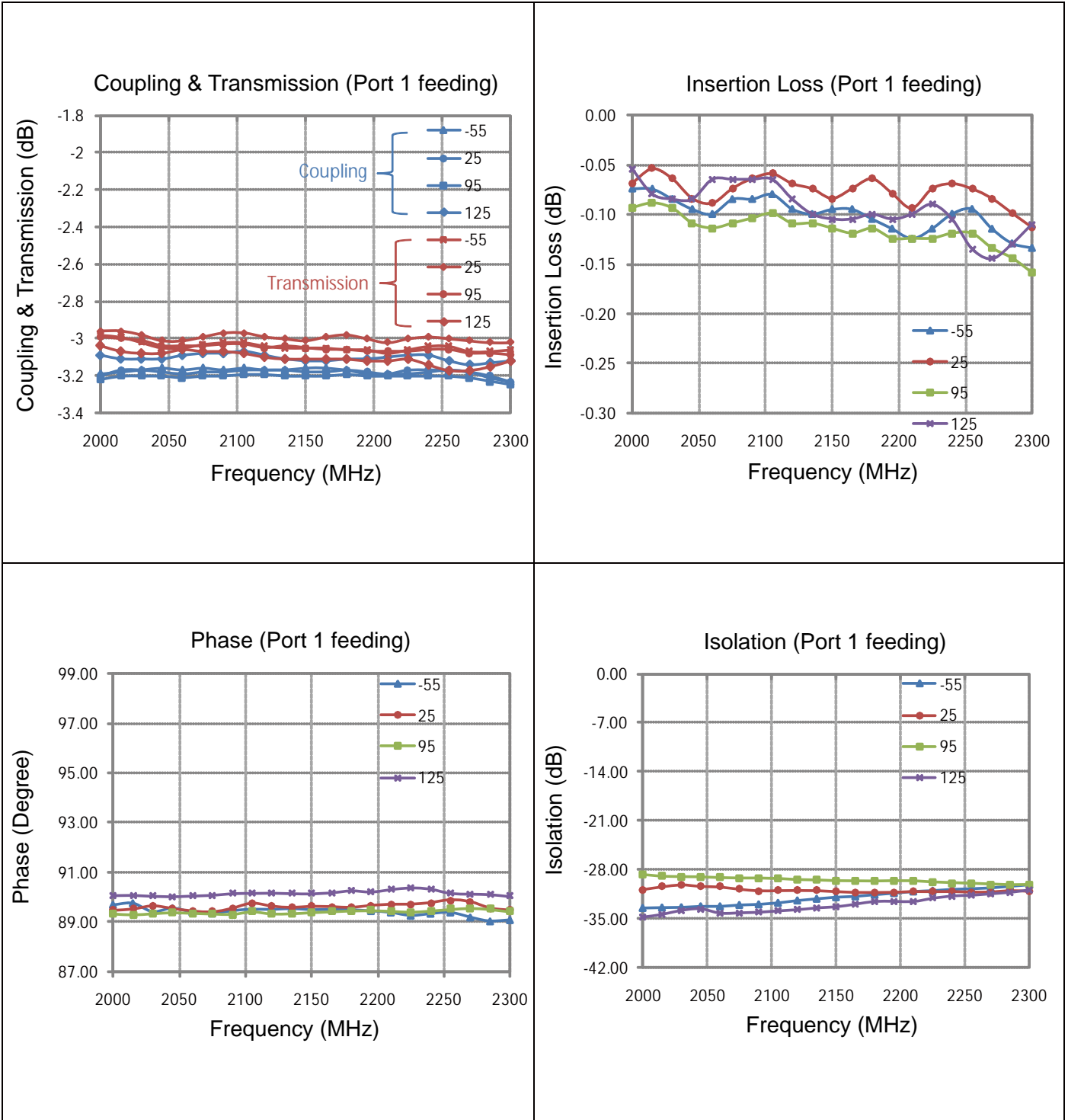

Yantel Corporation

Add : 3F, Building 3, Southern District 2 of Zhongguan Honghualing Industrial Park, Xili, Nanshan, Shenzhen, China
 Tel : 86-755-8355-1886 Fax : 86-755-8355-2533

For detailed performance specs & shopping online see Yantel web site : www.yantel-corp.com

Definition of Measured Specifications

Parameter	Definition	Mathematical Representation
VSWR (Voltage Standing Wave Ratio)	The impedance match of the coupler to a 50Ω system. A VSWR of 1:1 is optimal.	$VSWR = \frac{V_{max}}{V_{min}}$ Vmax = voltage maxima of a standing wave Vmin = voltage minima of a standing wave
Return Loss	The impedance match of the coupler to a 50Ω system. Return Loss is an alternate means to express VSWR.	$\text{Return Loss (dB)} = 20 \log \frac{VSWR + 1}{VSWR - 1}$
Insertion Loss	The input power divided by the sum of the power at the two output ports.	$\text{Insertion Loss(dB)} = 10 \log \frac{P_{in}}{P_{cpl} + P_{transmission}}$
Isolation	The input power divided by the power at the isolated port.	$\text{Isolation(dB)} = 10 \log \frac{P_{in}}{P_{iso}}$
Phase Balance	The difference in phase angle between the two output ports.	Phase at coupled port – Phase at transmission port
Amplitude Balance	The power at each output divided by the average power of the two outputs.	$10 \log \left(\frac{P_{cpl}}{P_{cpl} + P_{transmission}} \right) \text{ and } 10 \log \left(\frac{P_{transmission}}{P_{cpl} + P_{transmission}} \right)$

Test Method

1. Calibrating your vector network analyzer.
2. Connect the VNA 4 Port to DUT respectively.
3. Measure the data of coupling through port 1 to port 4(S41).
4. Measure the data of transmission through port 1 to port 3(S31).
5. Measure the data of isolation through port 1 to port 2(S21).
6. Measure the data of phase port 4 & port 3(port 1 feeding).
7. Measure the data of return loss port 1, port 2, port 3 & port 4.
8. According to the above data to calculate insertion loss, amplitude balance & phase.

Note:

1. When calculating insertion loss at room temperature, demo board loss should be removed from both coupling & transmission data.

Please refer to the below table for demo board loss :

Frequency Range(MHz)	Demo Board Loss (dB) @25
470-860	0.07
800-1000	0.10
1200-1700	0.15
1700-2000	0.15
2000-2300	0.20
2300-2700	0.25

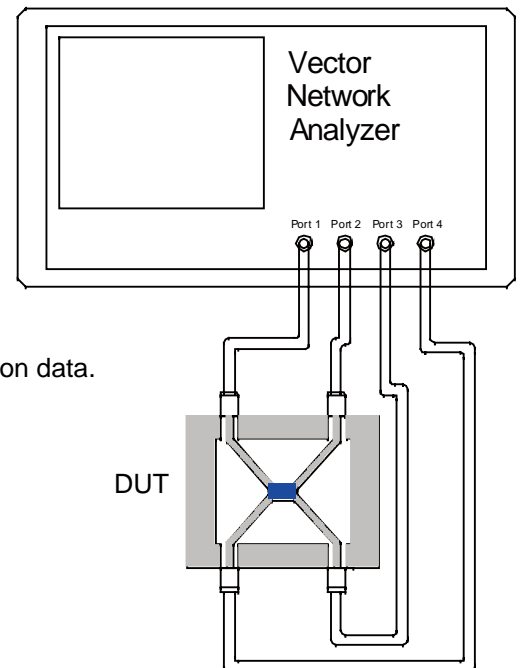

Yantel Corporation

Add : 3F, Building 3, Southern District 2 of Zhongguan Honghualing Industrial Park, Xili, Nanshan, Shenzhen, China
 Tel : 86-755-8355-1886 Fax : 86-755-8355-2533

For detailed performance specs & shopping online see Yantel web site : www.yantel-corp.com

Recommended PCB Layout

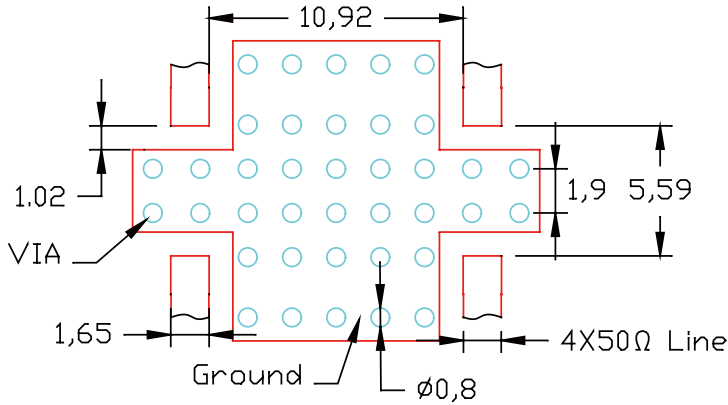

NOTE:

1. 50Ω line width is shown above designing from RO4350B dielectric thickness 0.762mm; copper 1 OZ
2. Bottom side of the PCB is continuous ground plane.
3. All dimensions shown in mm.

Reflow Profile

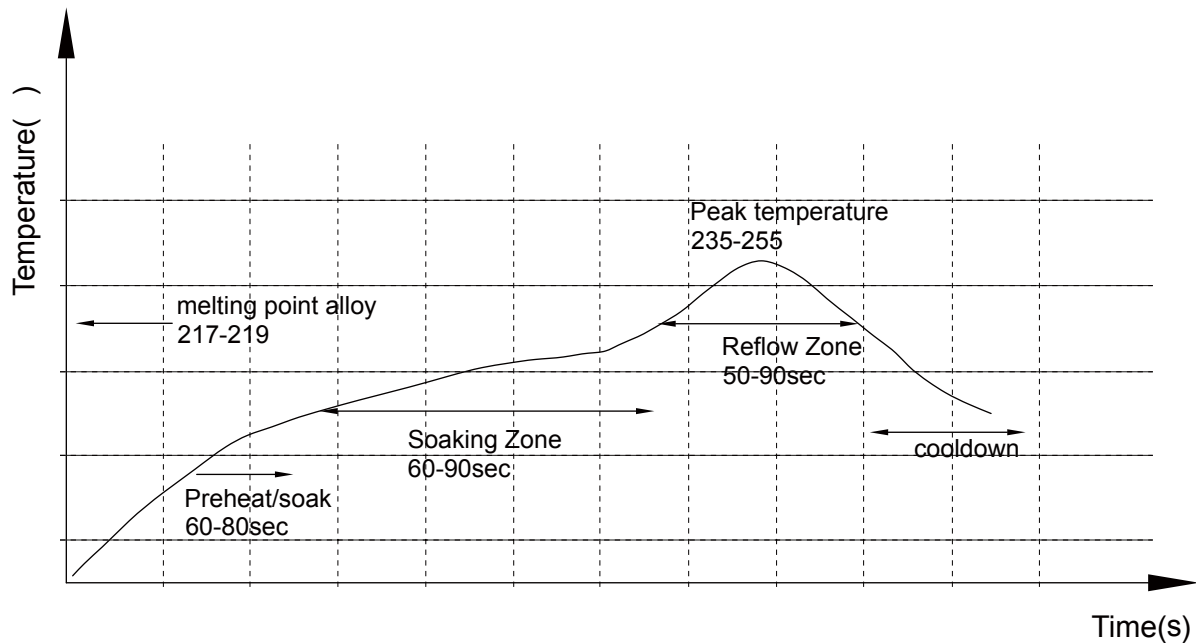

Yantel Corporation

Add : 3F, Building 3, Southern District 2 of Zhongguan Honghualing Industrial Park, Xili, Nanshan, Shenzhen, China
 Tel : 86-755-8355-1886 Fax : 86-755-8355-2533

For detailed performance specs & shopping online see Yantel web site : www.yantel-corp.com

Tape and Reel Drawing

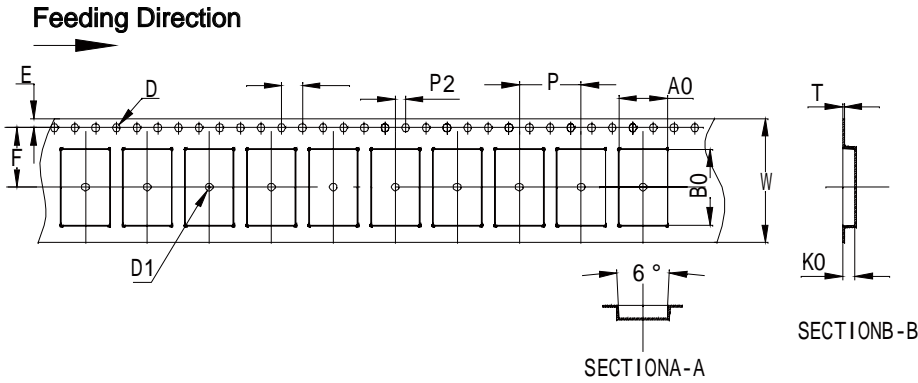

Notice:

- A. 10 Sprocket hole pitch cumulative tolerance is 0.2mm.
- B. Carrier camber shall be not more than 1mm per 100mm through a length of 250mm.
- C. All dimensions meet EIA-418-B requirements.
- D. A0 & B0 measured as indicated.
- E. K0 measured from a place on the inside bottom of the pocket to top surface of carrier.
- F. Material: PE 100
- G. Thickness: 0.30±0.05mm
- H. 2000 units (maximum) / T&R

ITEM	W	A0	B0	K0	P	F	E	D	D1	P0	P2	T	13"	
DIM(mm)	24.00	9.30	14.70	2.40	12.00	11.50	1.75	1.50	1.50	4.00	2.00	0.30	MR	P/R
TOLE	+0.30 -0.30	+0.10 -0.10	+0.10 -0.10	+0.10 -0.10	+0.10 -0.10	+0.10 -0.10	+0.10 -0.10	+0.10 -0.00	+0.10 -0.00	+0.10 -0.10	+0.10 -0.10	+0.05 -0.05	25.2MR	2000pcs

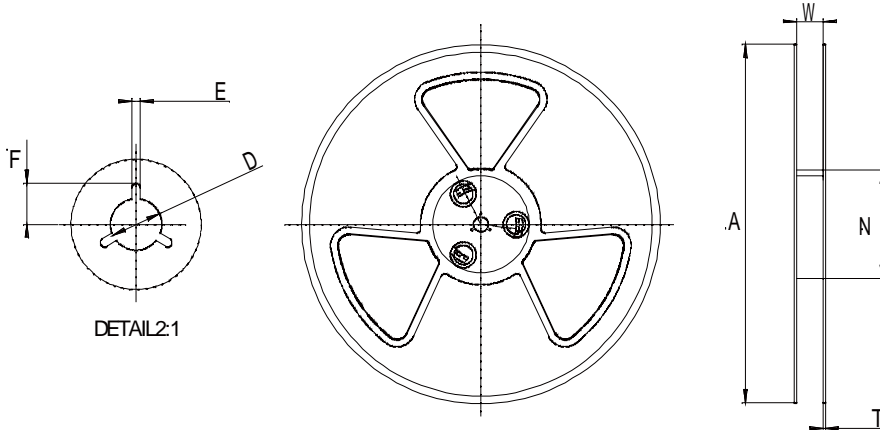

Symbol	Dimensions(mm)
W	24.5±0.4
A	330±0.5
N	100±0.3
T	1.8±0.2
E	2.1±0.3
F	10.75±0.3
D	13.5+0.5/-0.2

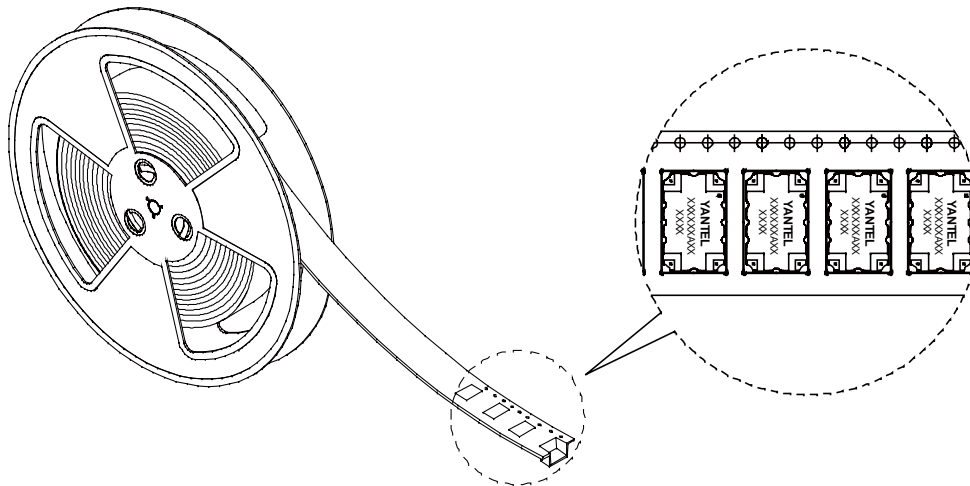

Yantel Corporation

Add : 3F, Building 3, Southern District 2 of Zhongguan Honghualing Industrial Park, Xili, Nanshan, Shenzhen, China
 Tel : 86-755-8355-1886 Fax : 86-755-8355-2533

For detailed performance specs & shopping online see Yantel web site : www.yantel-corp.com

Reliability Test Flow

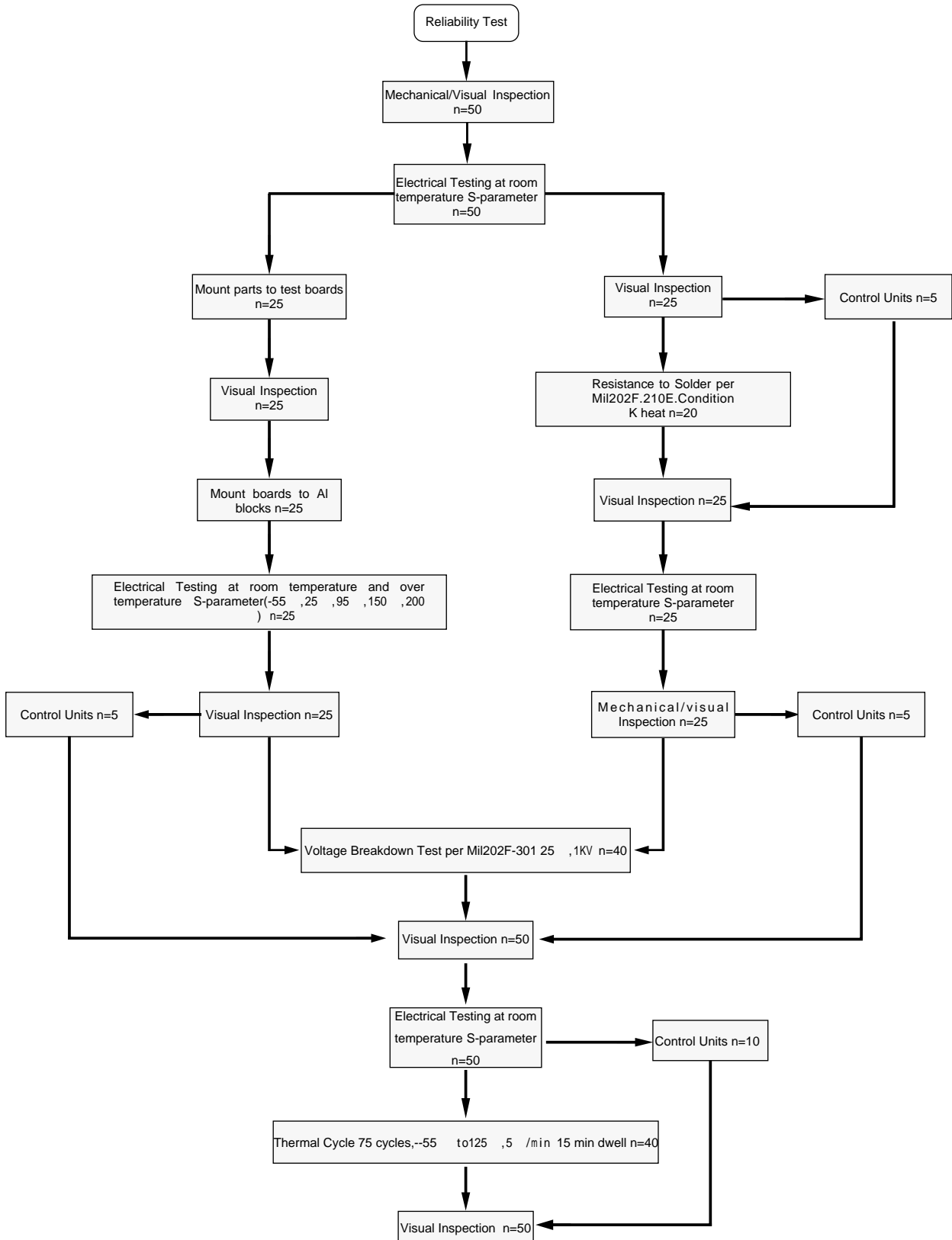

Reliability Test Flow

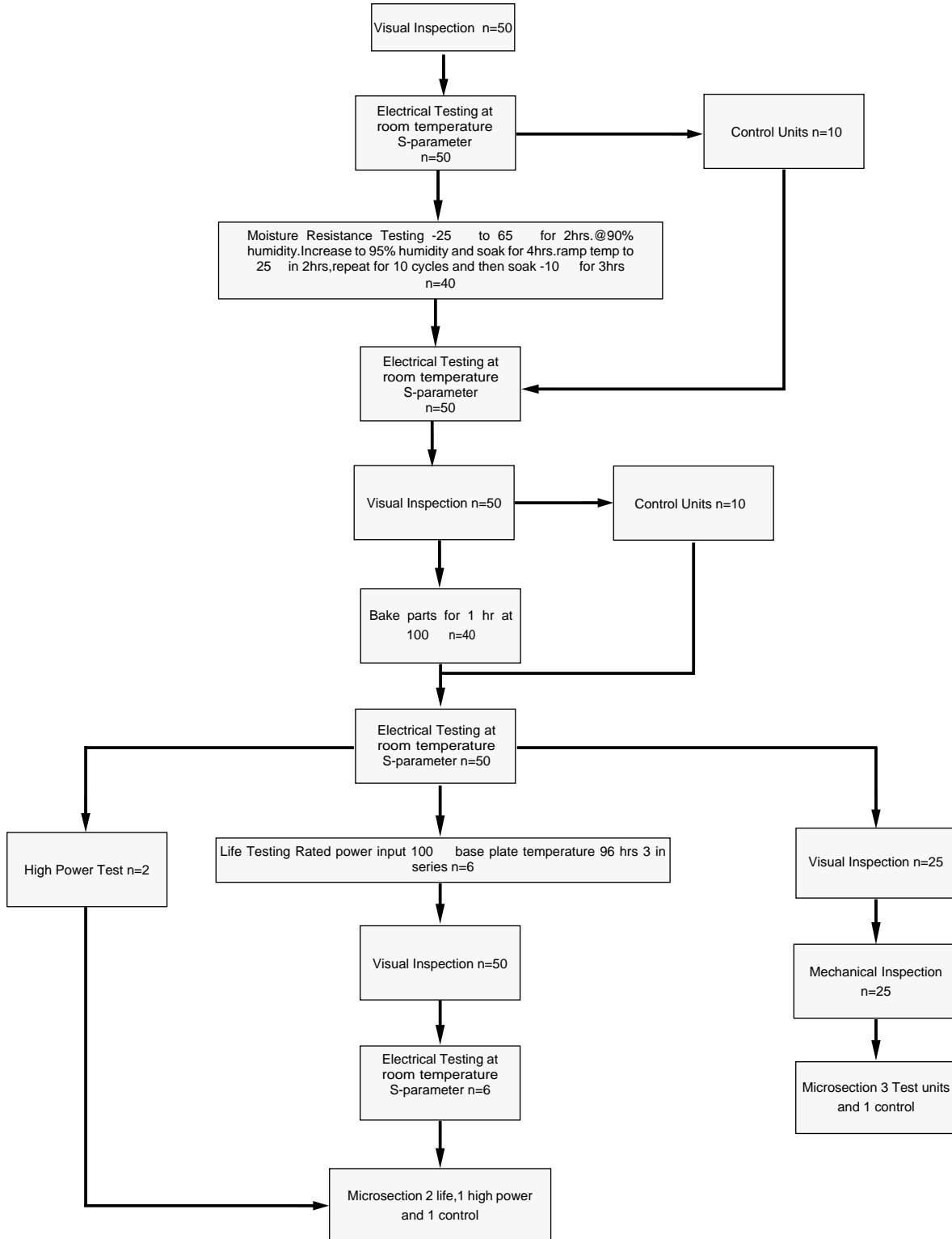



RoHS Test Report

SGS Job No. :SZ12995579
SGS Internal Reference No. :2.1
Tested sample information :HC1900A03
Client Reference Information :HC1900A03,;HC2100A03,;HC2500A03,HC0900E03,HC1900E03,
HC2100E03,HC2500E03
Date of Sample Received :MAR 09,2011
Testing Period :MAR 09,2011 TO MAR 14,2011
Test Requested :Selected test (s) with reference to EU COM(2008) 809/final as requested by client.
Test Method :Please refer to next page(s).
Test Result(s) :Please refer to next page(s).

A:RoHS Directive 2002/95/EC

Test Item(s)	Unit	Test Method (Reference)	Result	MDL	Limit
Cadmium (Cd)	mg/kg	IEC 62321 : 2008, ICP-OES	N.D.	2	100
Lead(Pb)	mg/kg	IEC 62321 : 2008, ICP-OES	7	2	1000
Mercury(Hg)	mg/kg	IEC 62321 : 2008, ICP-OES	N.D.	2	1000
Hexavalent Chromium (CrVI) by	mg/kg			2	1000
Sum OF PBBs	mg/kg	-	N.D.	-	1000
Sum OF PBDEs	mg/kg	-	N.D.	-	1000

B:HBCDD & Phthalate(s)

Test Item(s)	Unit	Test Method (Reference)	Result	MDL
Hexabromocyclododecane (HBCDD)	mg/kg	EPA 3550C:2007, GC-MS	N.D.	10
Dibutyl Phthalate (DBP)	%(W/W)	EN14372:2004, GC-MS	N.D.	0.003
Benzylbutyl Phthalate (BBP)	%(W/W)	EN14372:2004, GC-MS	N.D.	0.003
Di-(2-ethylhexyl) Phthalate (DEHP)	%(W/W)	EN14372:2004, GC-MS	N.D.	0.003

Note:

- 1.mg/kg=ppm,01%=1000ppm
- 2.N.D.=Not detected(<MDL)
- 3.MDL=Method Detection Limit
- 4."-"=Not regulated

Yantel Corporation

Add : 3F, Building 3, Southern District 2 of Zhongguan Honghualing Industrial Park, Xili, Nanshan, Shenzhen, China
Tel : 86-755-8355-1886 Fax : 86-755-8355-2533

For detailed performance specs & shopping online see Yantel web site : www.yantel-corp.com