

HCD-GNZ55D

SERVICE MANUAL

E Model

Ver. 1.1 2006. 10



- HCD-GNZ55D is the tuner, deck, DVD and amplifier section in MHC-GNZ55D.

DVD Section	Model Name Using Similar Mechanism	HCD-GNZ7D/GNZ8D/GNZ9D
	DVD Mechanism Type	CDM74HF-DVBU101//C
	Optical Pick-up Name	KHM-310CAB/C2NP
Tape Deck Section	Model Name Using Similar Machanism	NEW

SPECIFICATIONS

Amplifier section

The following measured at AC 120, 127, 220, 240 V, 50/60 Hz

DIN power output (rated)

40 W + 40 W
(4 ohms at 1 kHz, DIN)

Continuous RMS power output (reference)

60 W + 60 W
(4 ohms at 1 kHz, 10% THD)

Inputs

MIC (phone jack): Sensitivity 1 mV,
impedance 10 kilohms

Outputs

VIDEO OUT (phono jack):

max. output level
1 Vp-p, unbalanced, Sync
negative load impedance
75 ohms

PHONES (stereo mini jack):

Accepts headphones of
8 ohms or more

FRONT SPEAKER: Use only the supplied speakers

Disc player section

System Compact disc and digital
audio and video system

Laser Semiconductor laser
(DVD: $\lambda=650$ nm,
CD: $\lambda=790$ nm)

Emission duration:
continuous

Frequency response DVD (PCM 48 kHz):
2 Hz – 22 kHz (± 1 dB)
CD: 2 Hz – 20 kHz (± 0.5 dB)

Video color system format

Latin American model:
NTSC
Other models: NTSC, PAL

– Continued on next page –

DVD DECK RECEIVER

9-887-296-02

2006J04-1

© 2006. 10

Sony Corporation

Home Audio Division

Published by Sony Techno Create Corporation

SONY®

HCD-GNZ55D

Tape deck section

Recording system 4-track 2-channel stereo
Frequency response 50 – 13,000 Hz (± 3 dB),
using Sony TYPE I tape

Tuner section

FM stereo, FM/AM superheterodyne tuner

FM tuner section

Tuning range 87.5 – 108.0 MHz
(50-kHz step)
Antenna FM lead antenna
Antenna terminals 75 ohm unbalanced
Intermediate frequency 10.7 MHz

AM tuner section

Tuning range
Saudi Arabian model: 531 – 1,602 kHz (with the
interval set at 9 kHz)
Other models: 531 – 1,602 kHz (with the
interval set at 9 kHz)
530 – 1,710 kHz (with the
interval set at 10 kHz)
Antenna AM loop antenna
Antenna terminals External antenna terminal
Intermediate frequency 450 kHz

General

Power requirements
Saudi Arabian model: 120 – 127 V or 220 – 240 V AC,
50/60 Hz
Adjustable with voltage
selector
Thai model: 220 V AC, 50/60 Hz
Other models: 120 V or 220 – 240 V AC,
50/60 Hz
Adjustable with voltage
selector

Power consumption 45 watts

Dimensions (w/h/d) (Approx.)
280 × 326 × 385.5 mm

Mass (Approx.) 6.4 kg

*Design and specifications are subject to change without
notice.*

SAFETY-RELATED COMPONENT WARNING!!

COMPONENTS IDENTIFIED BY MARK \triangle OR DOTTED LINE
WITH MARK \triangle ON THE SCHEMATIC DIAGRAMS AND IN
THE PARTS LIST ARE CRITICAL TO SAFE OPERATION.
REPLACE THESE COMPONENTS WITH SONY PARTS WHOSE
PART NUMBERS APPEAR AS SHOWN IN THIS MANUAL OR
IN SUPPLEMENTS PUBLISHED BY SONY.

Notes on Chip Component Replacement

- Never reuse a disconnected chip component.
- Notice that the minus side of a tantalum capacitor may be damaged by heat.

Flexible Circuit Board Repairing

- Keep the temperature of soldering iron around 270°C during repairing.
- Do not touch the soldering iron on the same conductor of the circuit board (within 3 times).
- Be careful not to apply force on the conductor when soldering or unsoldering.

UNLEADED SOLDER

Boards requiring use of unleaded solder are printed with the lead free mark (LF) indicating the solder contains no lead.

(Caution: Some printed circuit boards may not come printed with the lead free mark due to their particular size)

LF: LEAD FREE MARK

Unleaded solder has the following characteristics.

- Unleaded solder melts at a temperature about 40 °C higher than ordinary solder.

Ordinary soldering irons can be used but the iron tip has to be applied to the solder joint for a slightly longer time.

Soldering irons using a temperature regulator should be set to about 350 °C.

Caution: The printed pattern (copper foil) may peel away if the heated tip is applied for too long, so be careful!

- Strong viscosity

Unleaded solder is more viscous (sticky, less prone to flow) than ordinary solder so use caution not to let solder bridges occur such as on IC pins, etc.

- Usable with ordinary solder

It is best to use only unleaded solder but unleaded solder may also be added to ordinary solder.

CAUTION

Use of controls or adjustments or performance of procedures other than those specified herein may result in hazardous radiation exposure.

NOTES ON HANDLING THE OPTICAL PICK-UP BLOCK OR BASE UNIT

The laser diode in the optical pick-up block may suffer electrostatic breakdown because of the potential difference generated by the charged electrostatic load, etc. on clothing and the human body. During repair, pay attention to electrostatic break-down and also use the procedure in the printed matter which is included in the repair parts.

The flexible board is easily damaged and should be handled with care.

NOTES ON LASER DIODE EMISSION CHECK

The laser beam on this model is concentrated so as to be focused on the disc reflective surface by the objective lens in the optical pick-up block. Therefore, when checking the laser diode emission, observe from more than 30 cm away from the objective lens.

Laser component in this product is capable of emitting radiation exceeding the limit for Class 1.

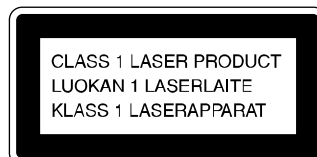

This appliance is classified as a CLASS 1 LASER product. This label is located on the rear exterior.

NOTE ON REPLACEMENT OF DMB15 BOARD

New part of EEPROM (IC103) on the DMB15 board cannot be used. Therefore, if the mounted DMB15 board (A-1167-778-A, etc.) is replaced, exchange new EEPROM (IC103) with that used before the replacement.

HCD-GNZ55D

MODEL IDENTIFICATION

– BACK PANEL –

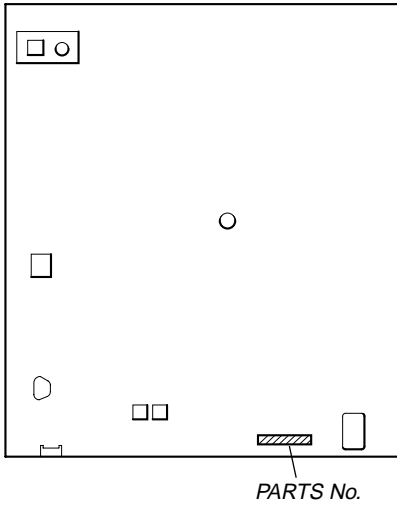

- Abbreviation

- E3 : 240 V AC area in E model
- E12 : 220-240 V AC area in E model
- E13 : 220-230 V AC area in E model
- E15 : Iran model
- EA : Saudi arabia model
- PH : Philippine model
- SP : Singapore model
- TH : Thai model
- MY : Malaysia model

MODEL	PARTS No.
E3, E15 models	2-663-832-0□
EA model	2-663-832-1□
MY, SP models	2-663-832-2□
E12, E13 models	2-663-832-3□
PH model	2-663-832-5□
TH model	2-663-832-6□

TABLE OF CONTENTS

1. GENERAL	
Main Unit	6
Remote Control	8
2. DISASSEMBLY	
2-1. Cabinet Steel Case	10
2-2. Loading Panel	10
2-3. Front Panel Section	11
2-4. DVD Block Section	11
2-5. Back Panel Section	12
2-6. Main Board, ADC Board	12
2-7. Speaker Board, S-Master Board	13
2-8. Power Unit	13
2-9. Tape Mechanism Deck	14
2-10. Holder TC-R Assy, Holder TC-L Assy	14
2-11. Mic Board	15
2-12. Video Board	15
2-13. DMB15 Board	16
2-14. Sensor Board	16
2-15. Motor (TB) Board	17
2-16. Motor (LD) Board	17
2-17. Pick-Up Unit	18
2-18. SW Board, Driver Board	18
3. TEST MODE	19
4. MECHANICAL ADJUSTMENTS	23
5. ELECTRICAL ADJUSTMENTS	24
6. DIAGRAMS	
6-1. Block Diagram — RF/Servo Section —	27
6-2. Block Diagram — Video Section —	28
6-3. Block Diagram — Main Section —	29
6-4. Block Diagram — Audio Section —	30
6-5. Block Diagram — Function/Power Section —	31
6-6. Circuit Boards Location	32
6-7. Printed Wiring Boards — Driver Section —	34
6-8. Schematic Diagram — Driver Section —	35
6-9. Printed Wiring Board — DMB15 Section —	36
6-10. Schematic Diagram — DMB15 Section (1/5) —	38
6-11. Schematic Diagram — DMB15 Section (2/5) —	39
6-12. Schematic Diagram — DMB15 Section (3/5) —	40
6-13. Schematic Diagram — DMB15 Section (4/5) —	41
6-14. Schematic Diagram — DMB15 Section (5/5) —	42
6-15. Printed Wiring Board — Main Section —	43
6-16. Schematic Diagram — Main Section (1/4) —	44
6-17. Schematic Diagram — Main Section (2/4) —	45
6-18. Schematic Diagram — Main Section (3/4) —	46
6-19. Schematic Diagram — Main Section (4/4) —	47
6-20. Printed Wiring Board — S-Master Section —	48
6-21. Schematic Diagram — S-Master Section (1/2) —	50
6-22. Schematic Diagram — S-Master Section (2/2) —	51
6-23. Printed Wiring Board — ADC Section —	52
6-24. Schematic Diagram — ADC Section —	53
6-25. Printed Wiring Boards — Panel Section —	54
6-26. Printed Wiring Board — Volume Section —	55
6-27. Schematic Diagram — Panel Section —	56
6-28. Printed Wiring Board — Mic Section —	57
6-29. Schematic Diagram — Mic Section —	58
6-30. Printed Wiring Board — Video Section —	59
6-31. Schematic Diagram — Video Section —	60
6-32. Printed Wiring Board — Speaker Section —	61
6-33. Schematic Diagram — Speaker Section —	62
7. EXPLODED VIEWS	
7-1. Main Section	75
7-2. Front Panel Section (1)	76
7-3. Front Panel Section (2)	77
7-4. Front Panel Section (3)	78
7-5. Chassis Section	79
7-6. DVD Block Section	80
7-7. DVD Mechanism Deck Section (1)	81
7-8. DVD Mechanism Deck Section (2)	82
8. ELECTRICAL PARTS LIST	83

SECTION 1 GENERAL

This section is extracted
from instruction manual.

List of button locations and reference pages

How to use page 104 to 106



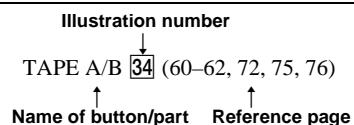







Use this page to find the location of buttons and other parts of the unit and remote that are mentioned in the text.















Unit

ALPHABETICAL ORDER













A — D

CD SYNC  (61)
Deck A  (60)
Deck B  (60–62, 75)
DIRECTION  (60–62, 73, 75)
DISC 1 ~ 3  (25, 28, 29)
DISC SKIP/EX-CHANGE  (11)
(18, 23, 25)
Disc tray  (18, 19, 23, 26–29,
33–36, 38, 69–71, 86, 87, 91)
DISPLAY  (21, 76, 77)
Display  (77)
DVD  (18, 19, 21, 24, 25, 61,
62, 67, 72, 76, 88)











E — O

ECHO LEVEL¹⁾  (67)
EQ BAND/MEMORY  (64)
GROOVE  (63)
ILLUMINATION  (58, 77, 90)
IR Receptor  (17, 85)
MASTER VOLUME  (24, 56,
74, 77, 85)
MIC²⁾ (jack)  (67, 72, 85, 94)
MIC 1¹⁾ (jack)  (67, 72, 85, 94)
MIC 2¹⁾ (jack)  (67, 72, 85, 94)
MIC LEVEL²⁾  (67, 72, 85)
MIC 1 LEVEL¹⁾  (67, 72, 85)
MIC 2 LEVEL¹⁾  (67, 72, 85)

P — Z

PHONES (jack)  (85, 94)
Power illuminator  (77)
PRESET EQ  (63, 64)
REC PAUSE/START  (61, 62,
72)
SOUND FIELD  (65, 83)
SUB WOOFER ON/OFF³⁾  (67)
TAPE A/B  (60–62, 72, 75, 76)
Tape lid  (60)
TUNER/BAND  (57–59, 76)
TUNING +/-  (57–59)
TV/SAT¹⁾  (62, 76, 84, 86)
VIDEO¹⁾  (62, 76, 84)
VIDEO INPUT¹⁾ (jacks)  (83,
94)

SYMBOLS

I/⏻ (on/standby)  (16, 18, 58,
84, 90)
▲ OPEN/CLOSE  (18, 19, 23,
25, 86)
◀▶ (play)  (24–27, 31, 33,
35, 36, 38, 48, 51, 60–62, 73,
75, 85, 87)
◀◀ OPERATION DIAL ▶▶
(go backward/forward)  (1)
(24, 32, 34, 39, 59, 62, 64, 65)
◀◀▶▶ (rewind/fast forward)
 (24, 60, 88)
◀▶▶▶  (25)
⏸ (pause)  (16)
■ (stop)  (61–62, 73, 86, 87,
90)
▲ PUSH (Eject A)  (60)
▲ PUSH (Eject B)  (60)

¹⁾Except for MHC-GNZ55D.

²⁾MHC-GNZ55D only.

³⁾MHC-GN999D/
MHC-GN999DS only.

Top view

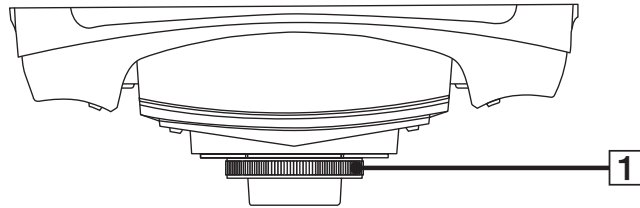

Front view

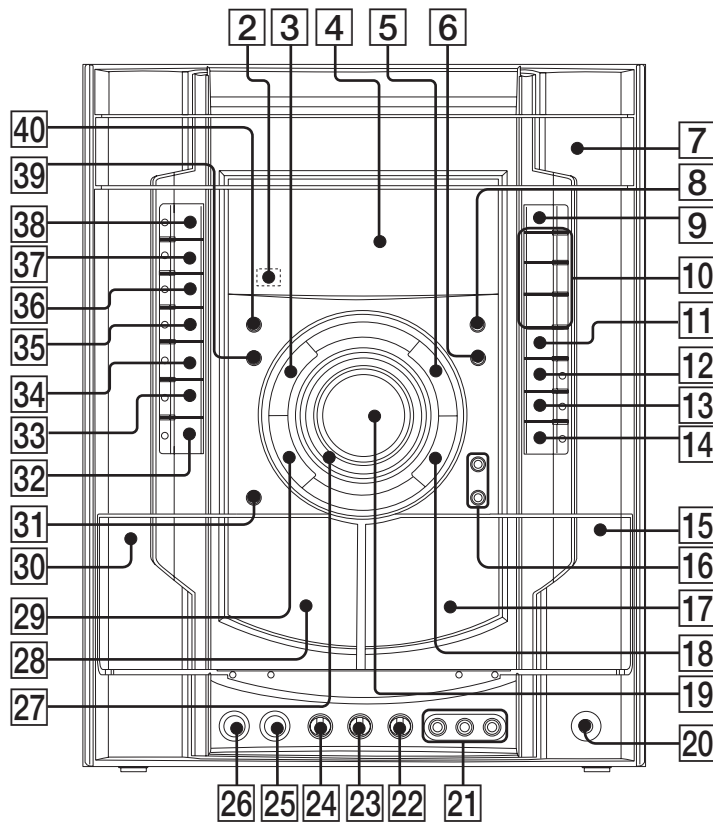

Additional Information

continued

105^{GB}

Remote control

ALPHABETICAL ORDER

A – L

- ADVANCE **▶▶▶** **24** (25)
- ALBUM +/- **11** (20, 24)
- ANGLE **10** (44)
- AUDIO **8** (34, 43, 67, 70, 83)
- CLEAR **28** (20, 27–30, 35, 41, 53)
- DISC SKIP **3** (25, 28, 29)
- DISPLAY **33** (21, 76, 77)
- ENTER **26** (18–20, 27–31, 34, 36–39, 40, 42, 45–50, 53, 56–59, 68–71, 74–76, 90)
- FM MODE **7** (59, 89)
- FUNCTION +/- **4** (19, 24, 57–60, 67, 75, 84, 88)
- KARAOKE MODE **31** (68, 88)
- KARAOKE PON **30** (68)
- KEY CONTROL **#/b** **32** (69)

M – S

- MENU **12** (30, 32, 34–36, 39, 57, 58)
- Numeric Buttons¹⁾²⁾ **29** (17, 20, 21, 24, 30, 31, 41, 46–50, 59)
- PICTURE NAVI **6** (35, 36, 41)
- PRESET + **16** (57–59)
- PRESET – **23** (57–59)
- REPEAT **7** (30)
- REPLAY **◀•** **24** (25)
- SCORE³⁾ **5** (72)
- SLEEP **35** (20, 74)
- SLOW **▶▶** **17** (25)
- SLOW **◀◀** **22** (25)
- SOUND FIELD **5⁴⁾** **13³⁾** (65, 83)
- STEP **▶▶▶** **24** (25)
- SUBTITLE **9** (44)

T – Z

- THEATRE SYNC **1** (21)
- TIMER MENU **36** (18, 74–76)
- TIME/TEXT **34** (77–79)
- TOP MENU **27** (30)
- TUNING + **17** (57–59)
- TUNING – **22** (57–59)
- TV²⁾ **20** (17)
- TV CH +²⁾ **16** (17)
- TV CH –²⁾ **23** (17)
- TV/VIDEO²⁾ **35** (17)
- TV VOL +/-¹⁾²⁾ **14** (17)
- TV **I/⏻** (on/standby)²⁾ **2** (17)
- VOLUME +/-¹⁾ **14** (24, 56, 74, 77, 85)

NUMBERS AND SYMBOLS

- I/⏻** (on/standby) **2** (16, 18, 74, 75, 85)
- (stop) **18** (24, 26, 32, 34–36, 39, 45, 58, 60, 75, 86, 87)
- ||** (pause) **19** (24, 60)
- ▷¹⁾** (play) **21** (24–27, 31, 33, 35, 36, 38, 48, 51, 60, 75, 85, 87)
- ▶▶▶** (go forward) **16** (21, 24, 32, 34, 39)
- ◀◀◀** (go backward) **23** (24, 32, 34, 39)
- ▶▶▶▶** (fast forward) **17** (24, 60, 88)
- ◀◀◀◀** (rewind) **22** (24, 60, 88)
- ↕/↔/↔/↔** **26** (18, 19, 27–31, 33–42, 45–50, 56, 65, 68–72, 74–76, 90)
- 10/0²⁾ **29**
- ./-²⁾ **28** (17)
- ↶** RETURN **25** (31, 34, 39, 42)
- ☒** DISPLAY **15** (9, 20, 26–31, 36, 37, 40–42, 45, 47, 49, 56, 68–72, 80, 90)
- ◀||** STEP **24** (25)

- 1) The numeric button 5, TV VOL +, VOLUME + and ▷ buttons have a tactile dot. Use the tactile dot as a reference when operating the system.
- 2) This button is used to operate a Sony TV. For details, see “Operating a Sony TV with the remote” on page 17.
- 3) MHC-GN999D/MHC-GN999DS/
MHC-GNZ88D/MHC-GNZ77D only.
- 4) MHC-GNZ55D only.

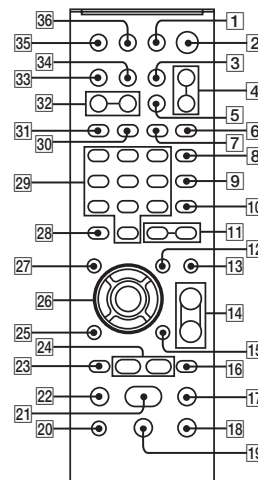

SECTION 2 DISASSEMBLY

Note : Disassemble the unit in the order as shown below.

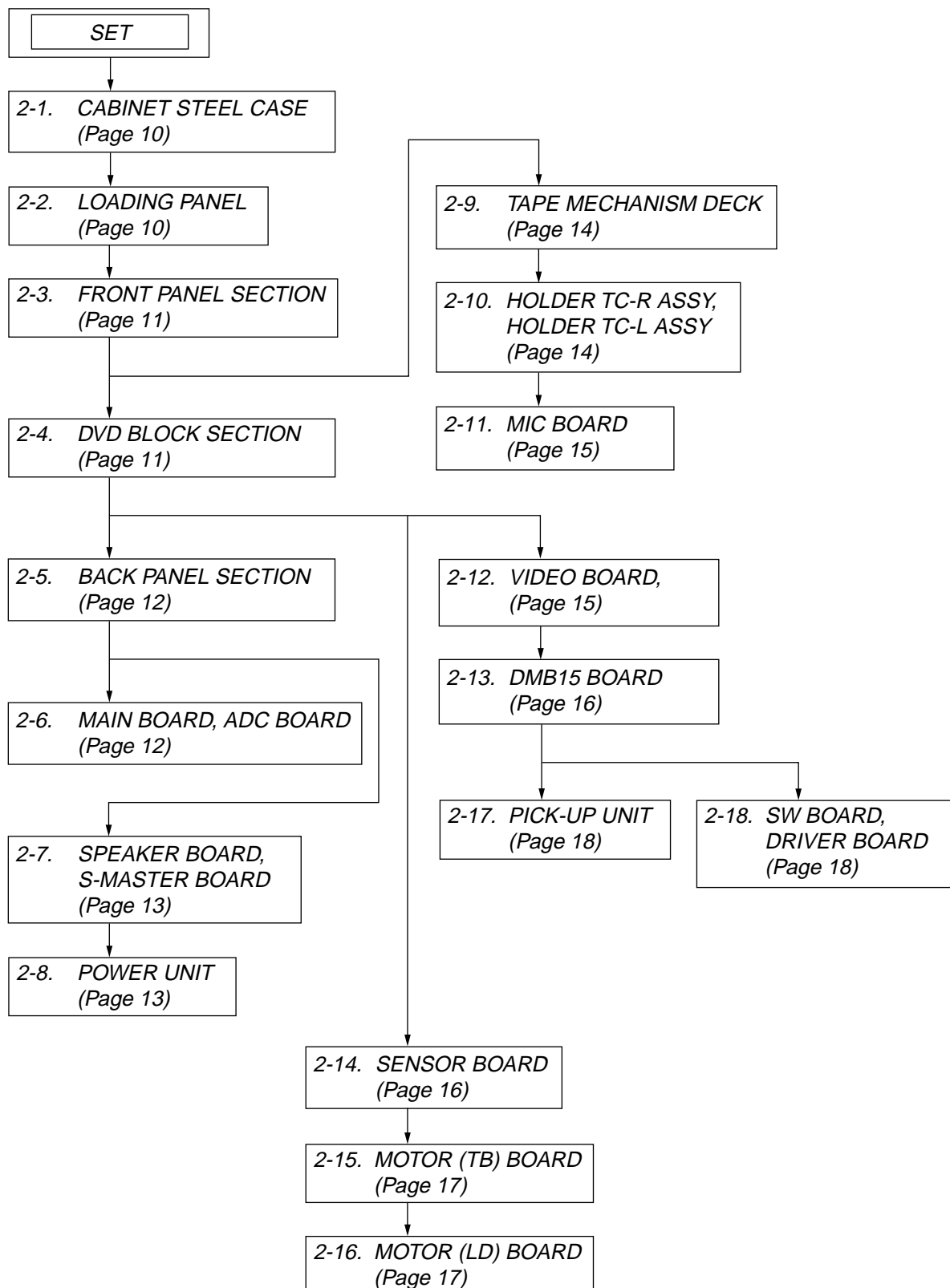

HCD-GNZ55D

Note : Follow the disassembly procedure in the numerical order given.

2-1. CABINET STEEL CASE

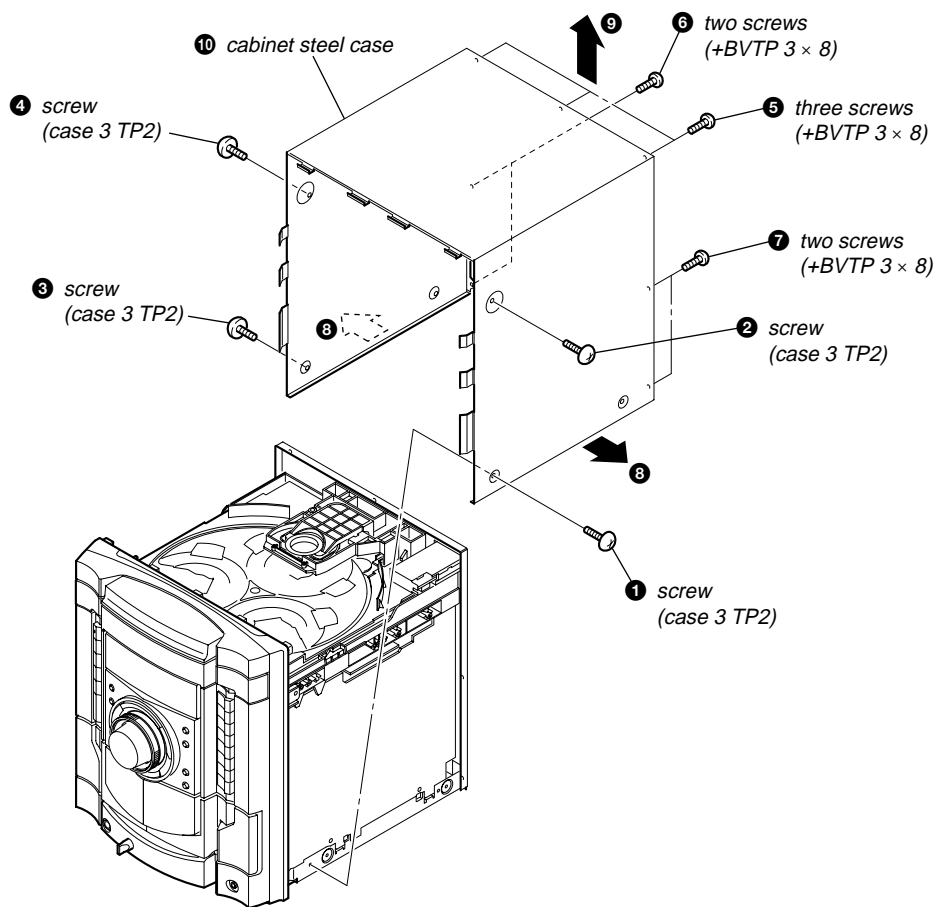

2-2. LOADING PANEL

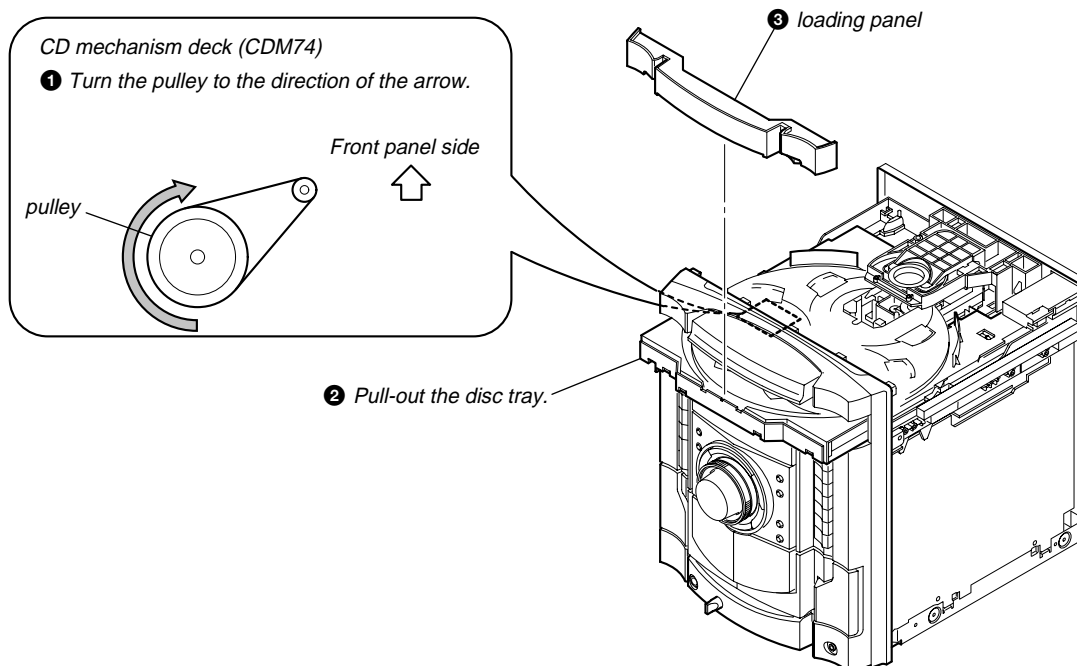

2-3. FRONT PANEL SECTION

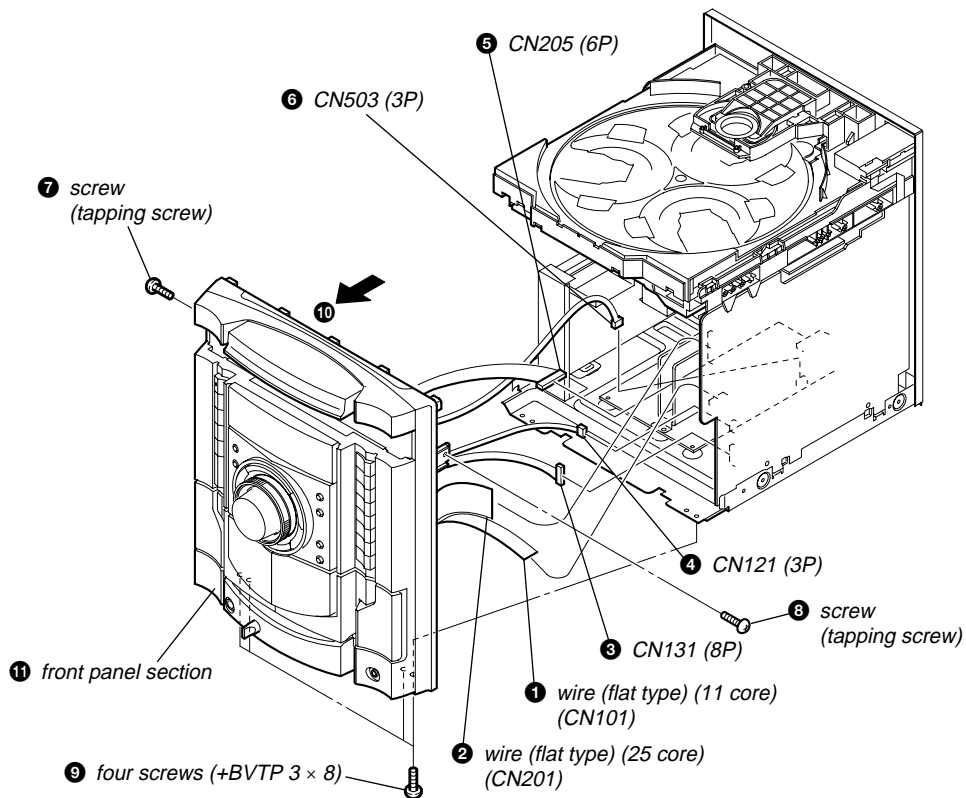

2-4. DVD BLOCK SECTION

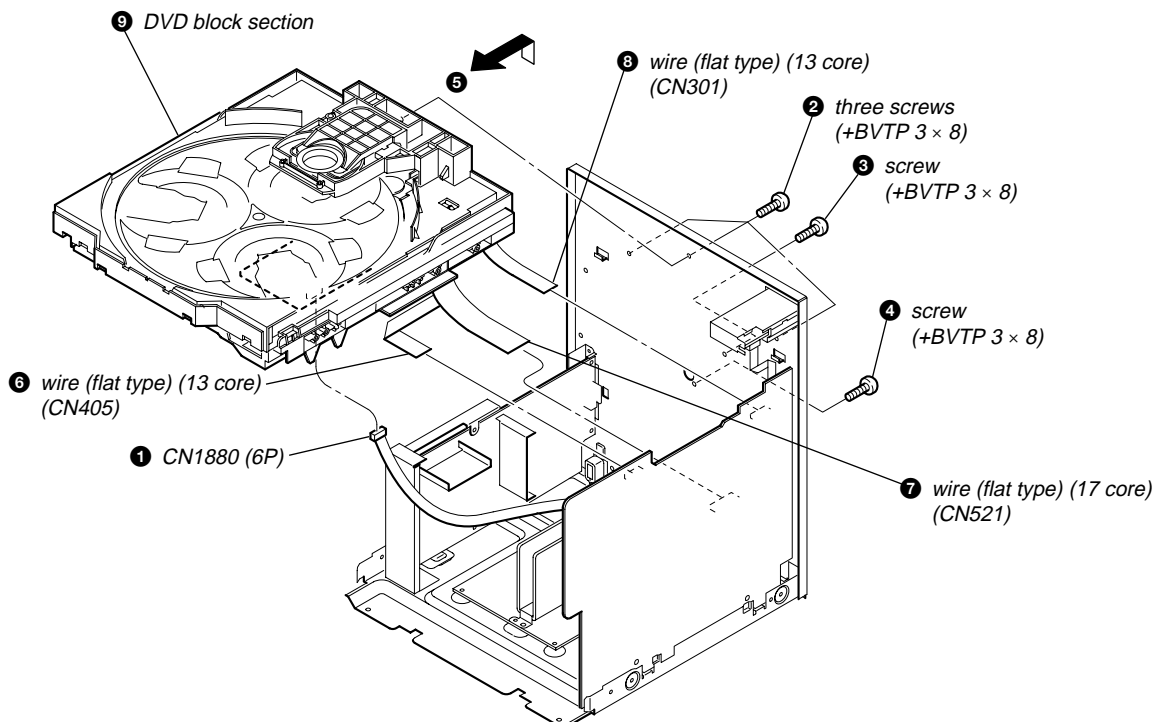

2-5. BACK PANEL SECTION

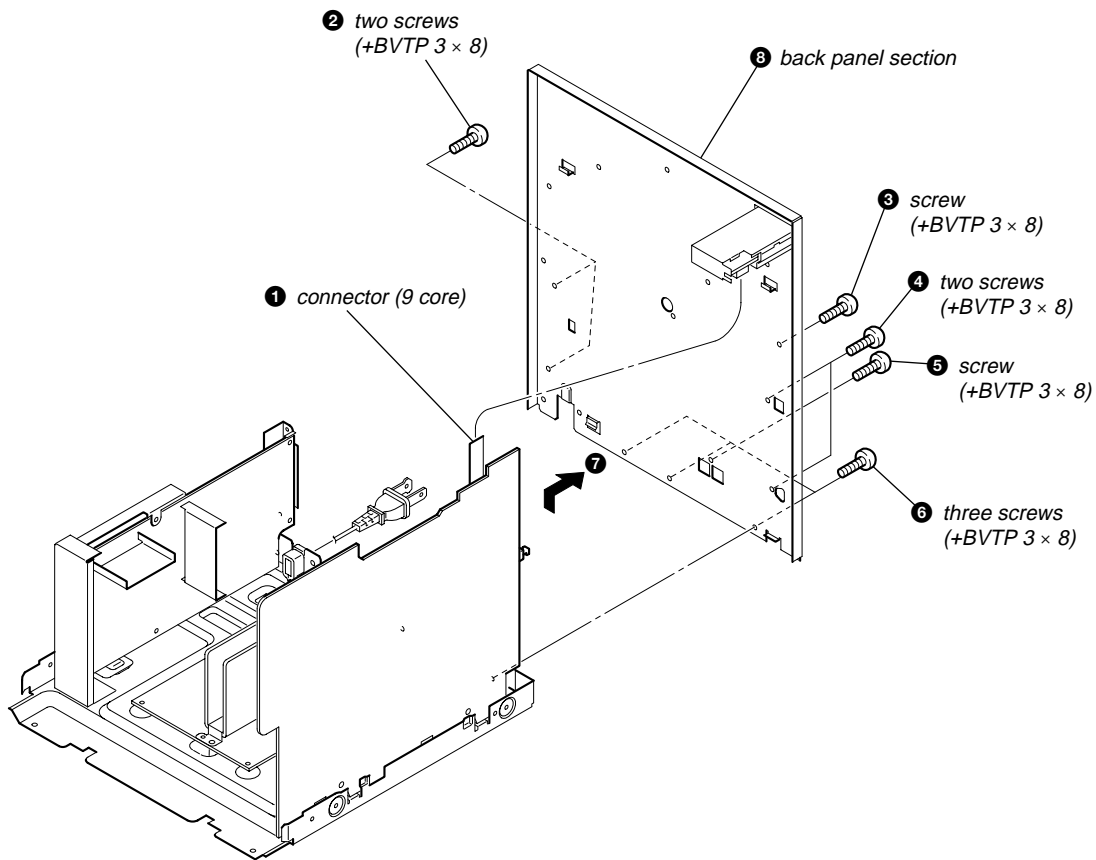

2-6. MAIN BOARD, ADC BOARD

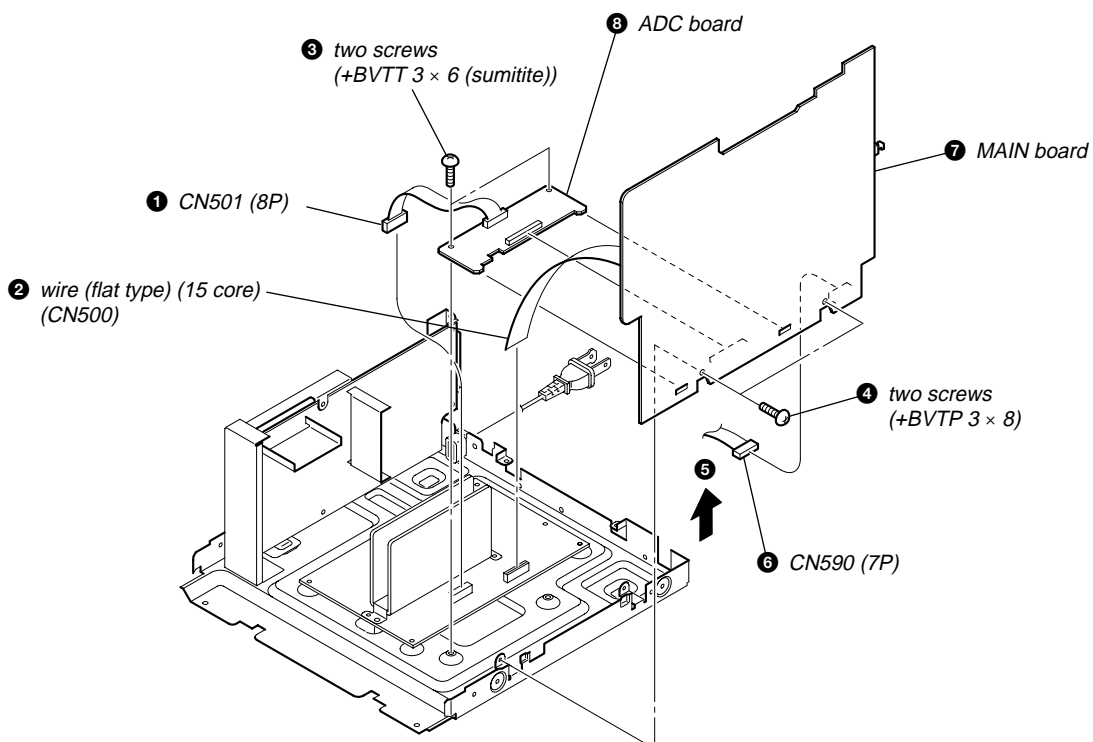

2-7. SPEAKER BOARD, S-MASTER BOARD

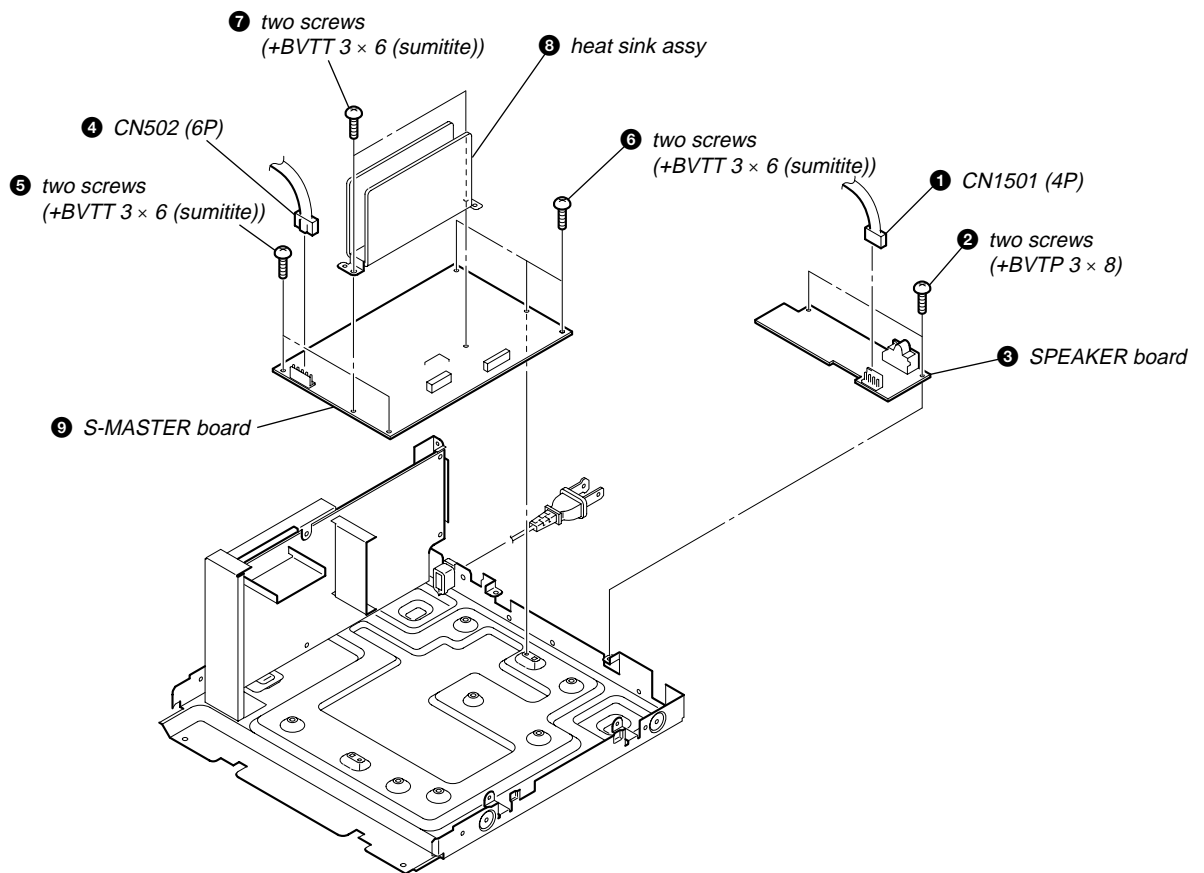

2-8. POWER UNIT

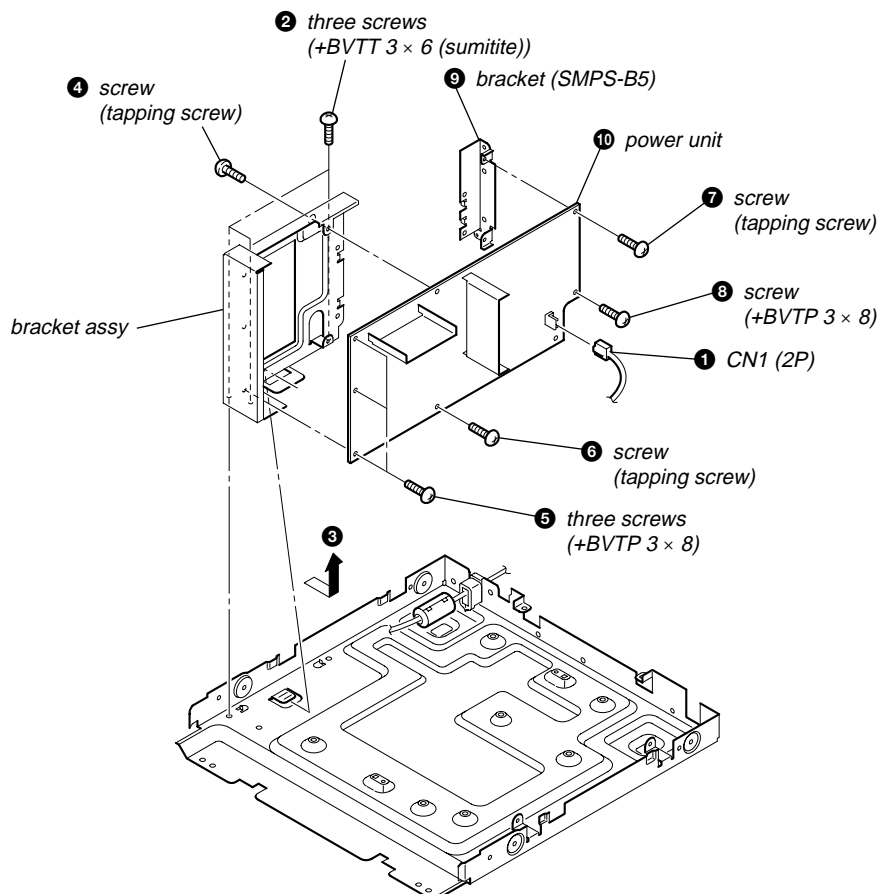

2-9. TAPE MECHANISM DECK

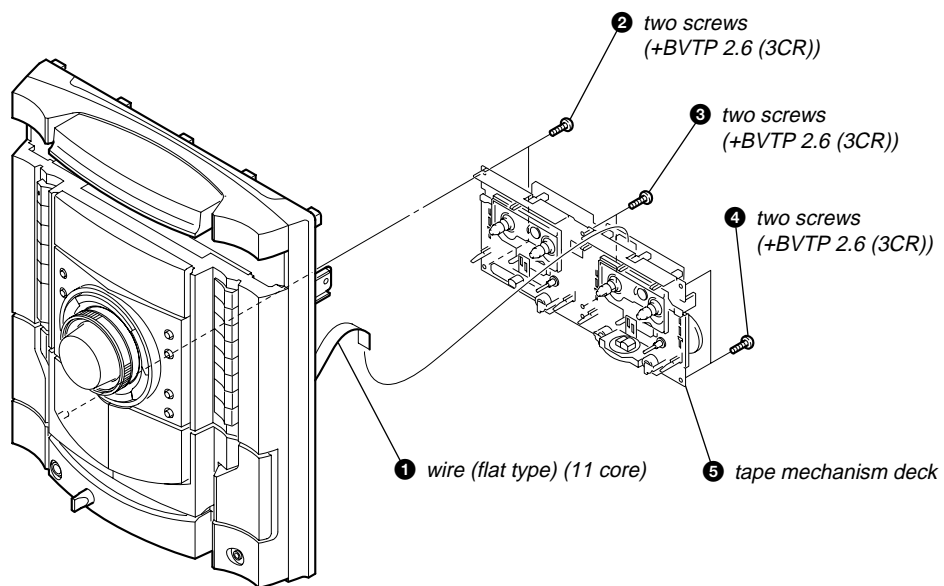

2-10. HOLDER TC-R ASSY, HOLDER TC-L ASSY

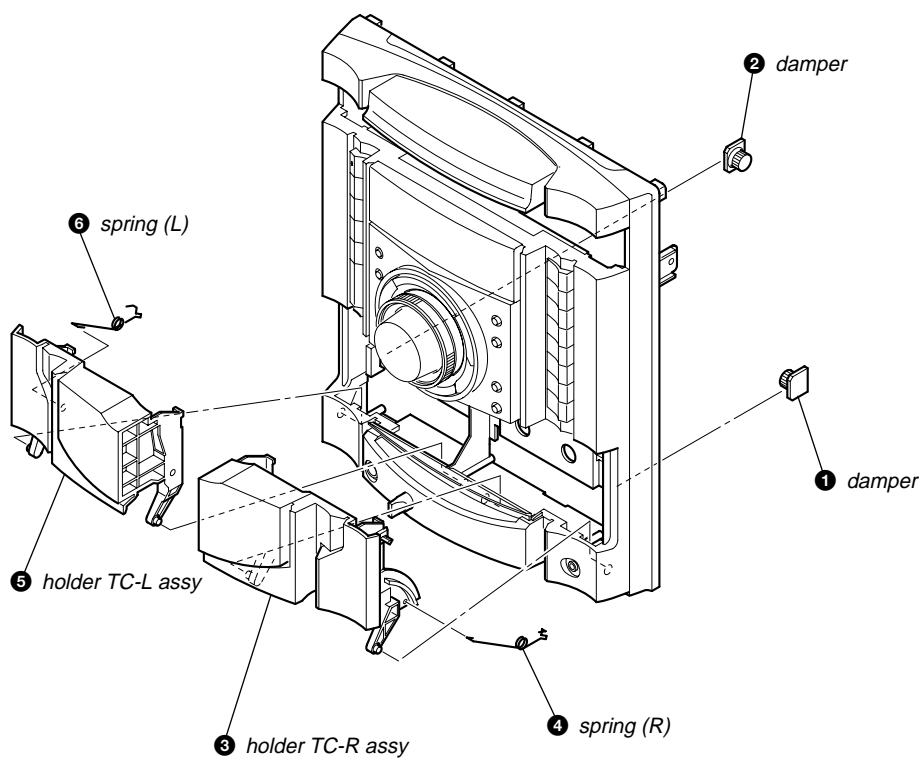

2-11. MIC BOARD

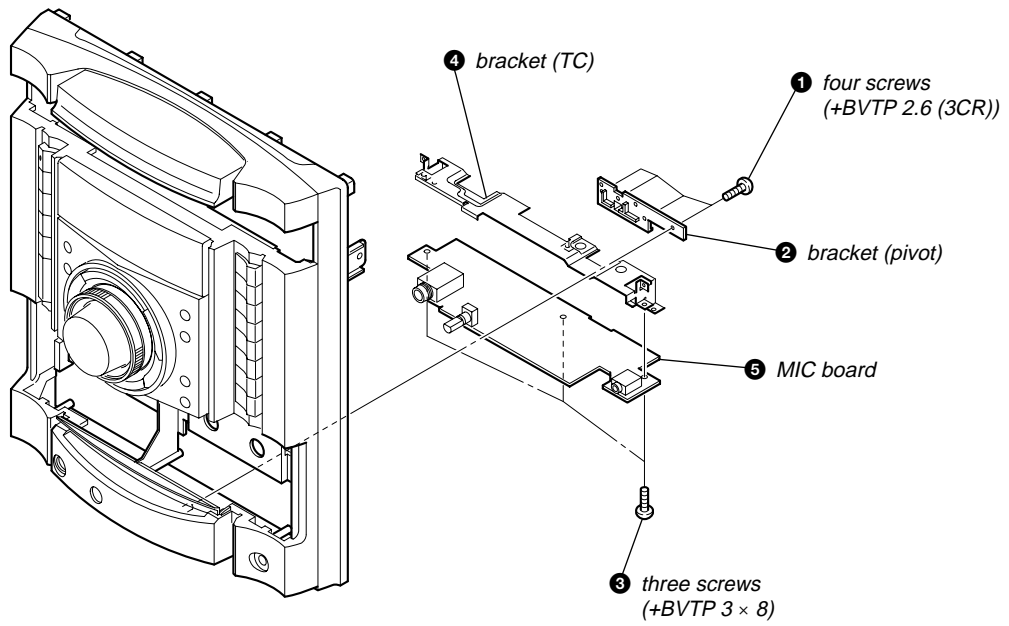

2-12. VIDEO BOARD

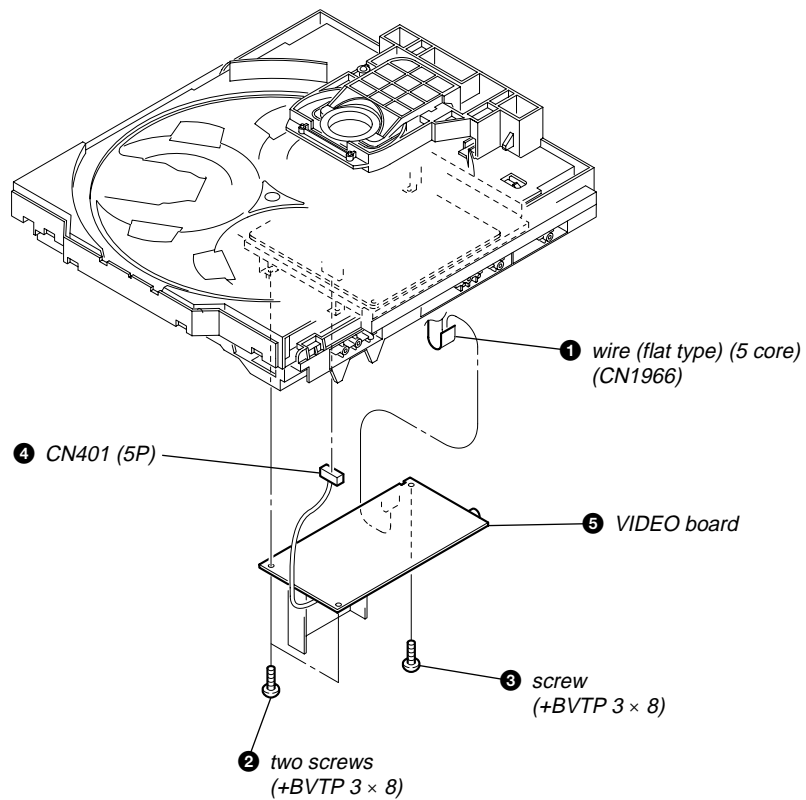

2-13. DMB15 BOARD

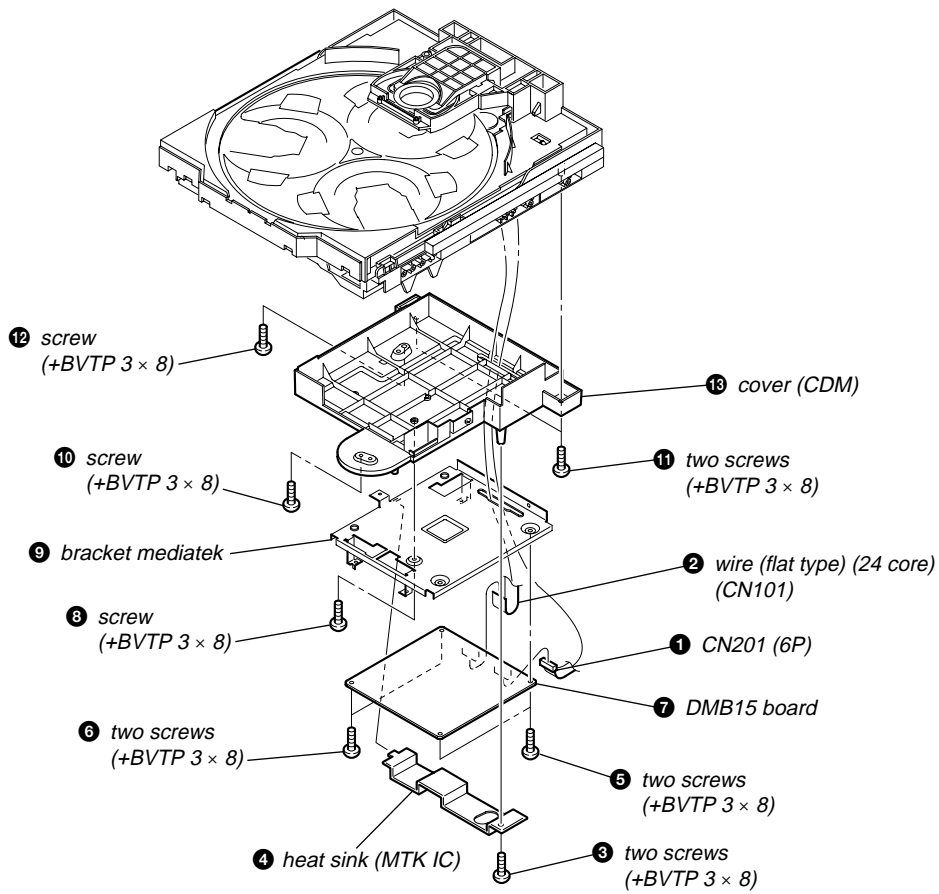

2-14. SENSOR BOARD

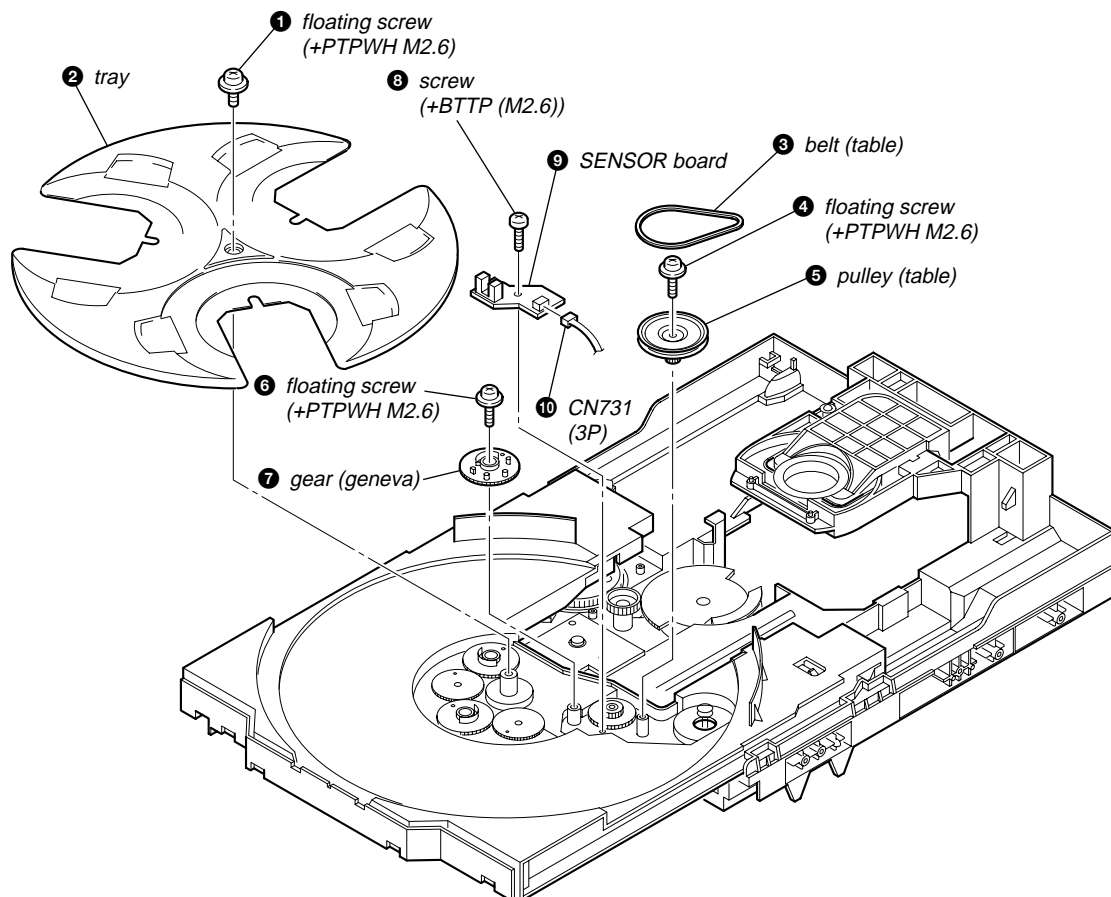

2-15. MOTOR (TB) BOARD

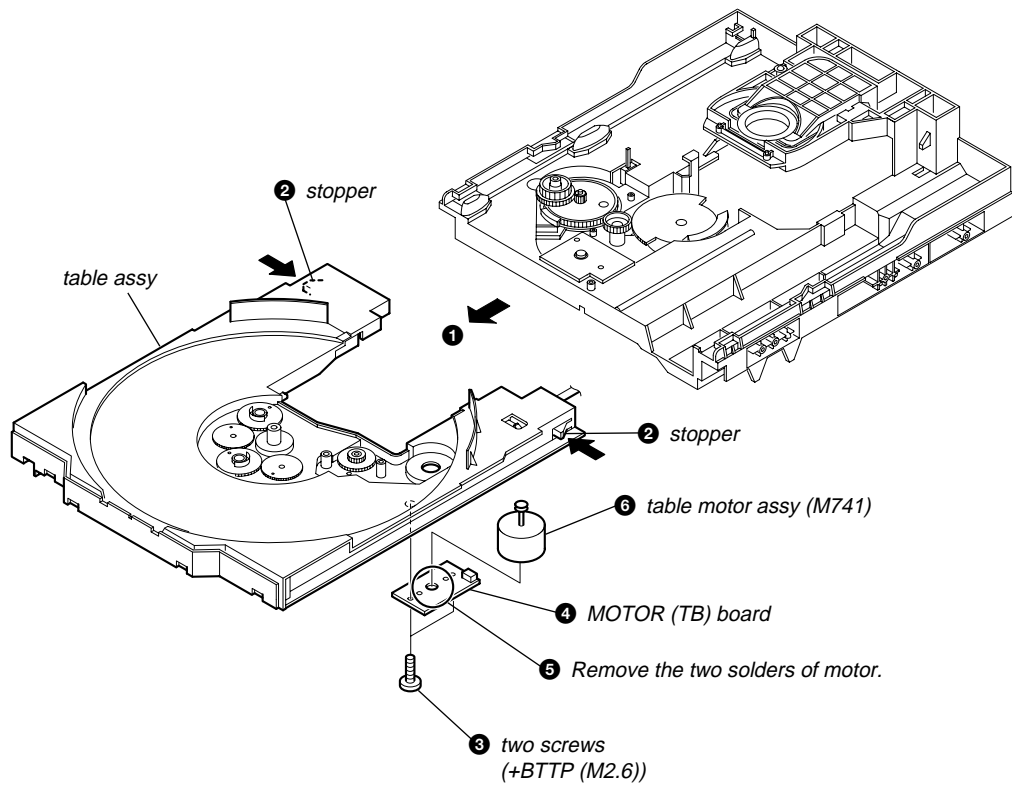

2-16. MOTOR (LD) BOARD

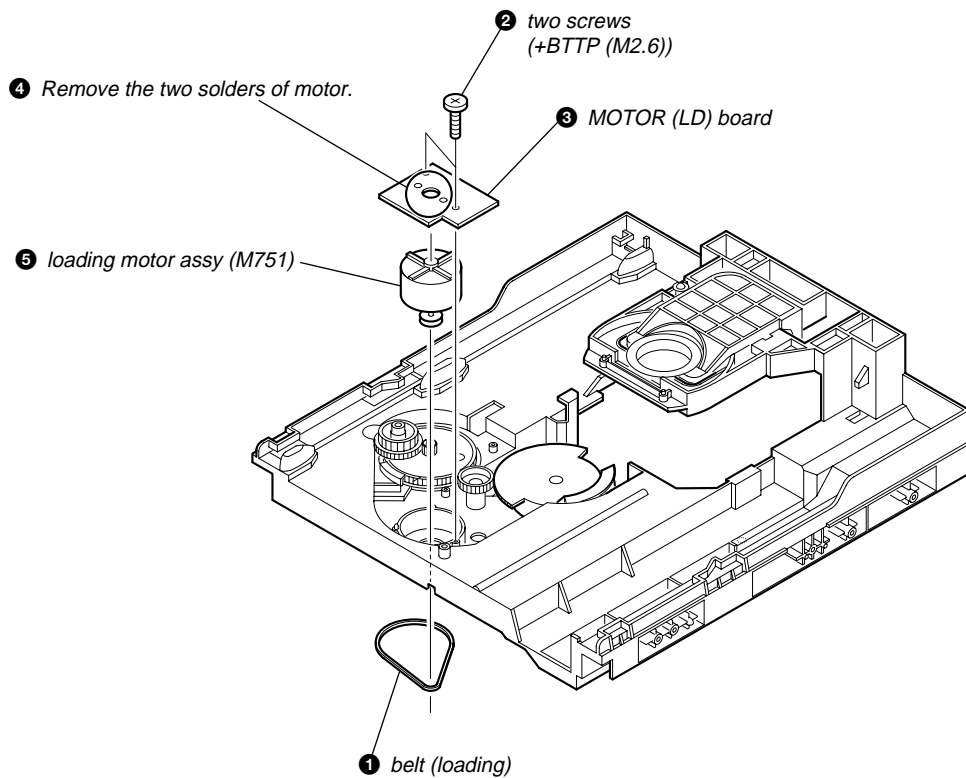

2-17. PICK-UP UNIT

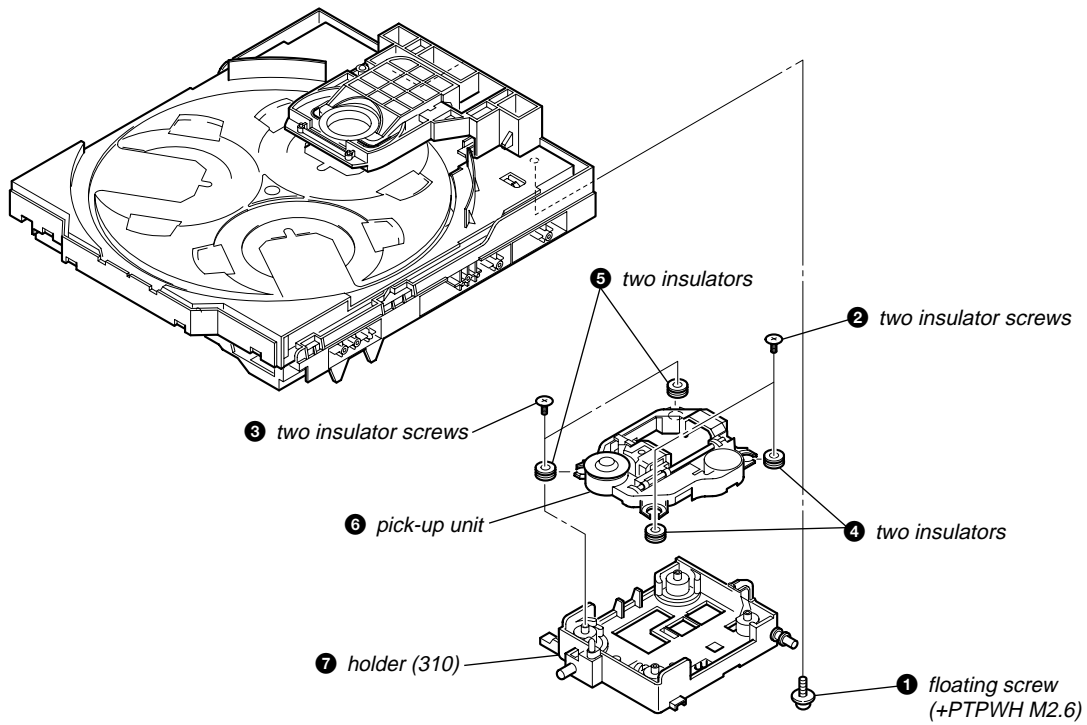

2-18. SW BOARD, DRIVER BOARD

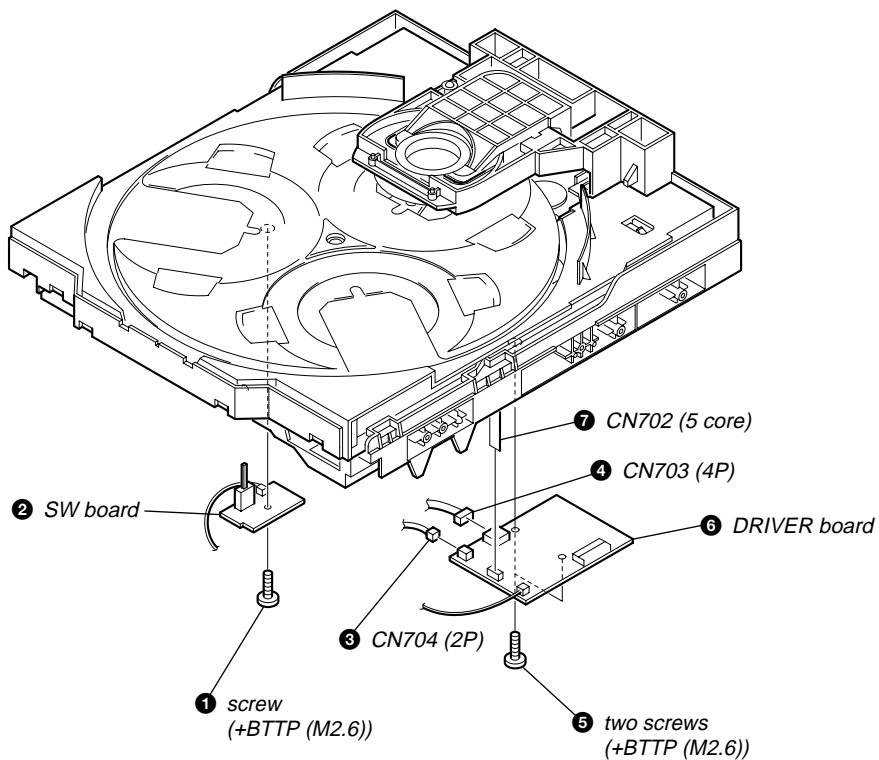

SECTION 3 TEST MODE

[PANEL TEST MODE]

- This mode is used to check the fluorescent indicator tube, LEDs, keys, VOLUME jog, model, destination, software version and VACS level.

Procedure:

- Press **[■]** button, **[ILLUMINATION]** button and **[DISC 2]** button simultaneously.
- All LEDs and segments in fluorescent indicator tube are lighted up.
- When you want to enter to the software version display mode, press **[DISC 1]** button. The model information appears on the fluorescent indicator tube. Press **[DISC 1]** button again to view the destination information.
- Each time **[DISC 1]** button is pressed, the display changes from MC version, SYS version, UI version, DVD version, CDMA version, CDMB version, ST version, TA version, TM version, TC version in this order, and returns to the model version display.
- When **[DISC 3]** button is pressed while the version numbers are being displayed except model and destination, the date of the software creation appears. When **[DISC 3]** button is pressed again, the display returns to the software version display. When **[DISC 1]** button is pressed while the date of the software creation is being displayed, the date of the software creation is displayed in the same order of software version display.
- Press **[DISC 2]** button, the key check mode is activated.
- In the key check mode, the fluorescent indicator tube displays "K 0 V0".
Turn the **[OPERATIONAL DIAL]** clockwise; "K" value increases by one. Turn the **[OPERATIONAL DIAL]** counterclockwise; "K" value increases by one. Each time a button is pressed, "K" value increases. Press other keys on main unit to check whether the key is detected. However, once a button has been pressed, it is no longer taken into account.
"V" value increases in the manner of 0, 1, 2, 3 ... if **[VOLUME]** knob is turned clockwise, or it decreases in the manner of 0, 9, 8, 7 ... if **[VOLUME]** knob is turned counterclockwise.
- When **[DISC 3]** button is pressed after all LEDs and segments in fluorescent indicator tube light up, the fluorescent indicator tube displays "VACS A". A is VACS level which is triggered by signal level.
- When **[DISC SKIP/EX-CHANGE]** button is pressed after all LEDs and segments in fluorescent indicator tube light up, alternate segments in fluorescent indicator tube would light up. If you press **[DISC SKIP/EX-CHANGE]** button again, another half of alternate segments in fluorescent indicator tube would light up. When **[DISC SKIP/EX-CHANGE]** button is pressed again, all segments lights off. Press **[DISC SKIP/EX-CHANGE]** button again would cause all segments lights up.
- To release from this mode, press three buttons in the same manner as step 1, or disconnect the power cord.

[COMMON TEST MODE]

- This mode is used to check operations of the respective sections of Amplifier and Tape.

Procedure:

- To enter Common Test Mode
- Press **[■]** button, **[ILLUMINATION]** button and **[DISC 3]** button simultaneously.
 - The DVD ring indicators and the line below DVD ring indicator flash synchronously on the fluorescent indicator tube.

• Check of Amplifier

- Press **[EQ BAND/MEMORY]** button repeatedly until a message "GEQ MAX" appears on the fluorescent indicator tube. GEQ increases to its maximum.
- Press **[EQ BAND/MEMORY]** button repeatedly until a message "GEQ MIN" appears on the fluorescent indicator tube. GEQ decreases to its minimum.
- Press **[EQ BAND/MEMORY]** button repeatedly until a message "GEQ FLAT" appears on the fluorescent indicator tube. GEQ is set to flat.
- When the **[VOLUME]** knob is turned clockwise even slightly, the sound volume increases to its maximum and a message "VOLUME MAX" appears on the fluorescent indicator tube.
- When the **[VOLUME]** knob is turned counterclockwise even slightly, the sound volume decreases to its minimum and a message "VOLUME MIN" appears on the fluorescent indicator tube.

• Tape function

- When a tape is inserted in Deck B and recording is started, the function is change to DVD automatically when a tape is inserted in Deck B and recording is started. When **[CD SYNC]** button is pressed during recording in function, ALC (Automatic Logic Control) is turned on.
- During recording, press **[◀▶]** button will stop the recording and the function is changed to TAPE B and rewind the tape in Deck B until the recording start position and playback of the tape in Deck B is started. If the **[REC PAUSE/START]** button is pressed for a pause and pressed again to resume recording during recording time, when the tape is rewind, the tape will be rewind until the position where the pause is applied.

• To release from Common Test mode

- To release from this mode, press **[I/⏻]** button.
- The cold reset is enforced at the same time.

[COLD RESET]

- The cold reset clears all data including preset data stored in the RAM to initial conditions. Execute this mode when returning the set to the customer.

Procedure:

- Press **[I/⏻]** button to turn on the system.
- Press **[■]** button, **[ILLUMINATION]** button, and **[I/⏻]** button simultaneously.
- The message "COLD RESET" appears on the fluorescent indicator tube. Then, the fluorescent indicator tube becomes blank for a while, and the system is reset.

[VACS ON/OFF]

- This mode is used to switch on and off the VACS (Variable Attenuation Control System).

Procedure:

- Press **[I/⏻]** button to turn on the system.
- Press **[■]** button, **[DIRECTION]** button and **[DISC 1]** simultaneously. The message "VACS OFF" or "VACS ON" appears on the fluorescent indicator tube.

[TUNER STEP CHANGE]

- The step interval of AM channels can be toggled between 9 kHz and 10 kHz. This mode is not available for Saudi Arabia and Russia models.

Procedure:

1. Press **I/⏻** button to turn on the system.
2. Press **TUNER/BAND** button repeatedly to select the "AM".
3. Press **I/⏻** button to turn off the system.
4. Press **ILLUMINATION** button and **I/⏻** button simultaneously. The system will turn on automatically. The message "AM 9K STEP" or "AM 10K STEP" appears on the fluorescent indicator tube and thus the channel step is changed.

[DVD SHIP MODE (WITH MEMORY CLEAR)]

- This mode moves the optical pick-up to the position durable to vibration and clears all data including preset data stored in the RAM to initial conditions. Use this mode when returning the set to the customer after repair.

Procedure:

1. Press **I/⏻** button to turn on the system.
2. Select DVD function.
3. Press **■** button, **DIRECTION** button and **I/⏻** button simultaneously during "DVD NO DISC" condition. The system will turn off automatically.
4. After the "STANDBY" blinking display finishes, a message "MECHA LOCK" appears on the fluorescent indicator tube and the DVD ship mode is set.

[DVD SHIP MODE (WITHOUT MEMORY CLEAR)]

- This mode moves the optical pick-up to the position durable to vibration. Use this mode when returning the set to the customer after repair.

Procedure:

1. Press **I/⏻** button to turn on the system.
2. Select DVD function.
3. Press **DVD** button and **I/⏻** button simultaneously during "DVD NO DISC" condition. The system will turn off automatically.
4. After the "STANDBY" blinking display finishes, a message "MECHA LOCK" appears on the fluorescent indicator tube and the DVD ship mode is set.

[DVD TRAY LOCK MODE]

- This mode let you lock the disc tray. When this mode is activated, the disc tray will not open when **OPEN/CLOSE** button or **DISC SKIP/EX-CHANGE** button is pressed. The message "LOCKED" will appears on the fluorescent indicator tube.

Procedure:

1. Press **I/⏻** button to turn on the system.
2. Select DVD function.
3. Press **■** button and **OPEN/CLOSE** button simultaneously and hold down until "LOCKED" or "UNLOCKED" appears on the fluorescent indicator tube (around 5 seconds).

[TCM OFFLINE MODE]

- This mode prevents the system from turning off automatically when TCM is not connected. Therefore, measurements can be done even when TCM is not connected during production.

Procedure:

1. When the system is turned off, press **EQ BAND/MEMORY** button, **TAPE A/B** button and **I/⏻** button simultaneously. The system will turn on automatically.
2. The message "TCM OFFLINE" will appears on the fluorescent indicator tube.

- To release from TCM Offline Mode

To release from this mode, perform "COLD RESET" or turn off the power supply.

[DVD COLOR SYSTEM]

- This mode let you change the color system of the video output from PAL to NTSC or vice-versa. This mode is not available for Latin American and Russian models.

Procedure:

1. Press **I/⏻** button to turn on the system.
2. Select DVD function.
3. Press **I/⏻** button again to turn off the system.
4. Press **■** button and **I/⏻** button simultaneously. The system will turn on automatically. The message "COLOR PAL" or "COLOR NTSC" appears on the fluorescent indicator tube.

[REMOTE DISABLE MODE]

- This mode let you disable the remote commander reception. When this mode is activated, the system will not response if the button on the remote commander is pressed. The message "RM DISABLE" appears on the fluorescent indicator tube. This mode is essential for conducting test and repairing when no interruption from the other remote commander is expected. This mode is cancelled automatically when the system is turned off.

Procedure:

1. Press **I/⏻** button to turn on the system.
2. Press **■** button, **DIRECTION** button and **DISC 3** button simultaneously until "SIRCS ON" or "SIRCS OFF" appears on the fluorescent indicator tube.

[MTK FIRMWARE DISPLAY]

- This mode is used to display the MTK firmware version.

Procedure:

1. Press **I/⏻** button to turn on the system.
2. Press **DVD** button to switch to DVD function.
3. Press **I/⏻** button again to turn off the system.
4. Press **■** button and **I/⏻** button. The system turns on automatically.
5. The version of MTK firmware appears on the TV screen.

[DVD SERVICE MODE]

- This mode let you make diagnosis and adjustment easily by using the remote commander and the TV. The instructions, diagnostic results, etc. are given on the on-screen display.

• TEST DISC LIST

Be sure to use the DVD disc that matches the signal standards of your region.

• CD

YEDS-18 (Part No.: 3-702-101-01)

PATD-012 (Part No.: 4-225-203-01)

• DVD SL (Single Layer)

NTSC : HLX-503 (Part No.: J-6090-069-A)

HLX-504 (Part No.: J-6090-088-A)

PAL : HLX-506 (Part No.: J-6090-077-A)

• DVD DL (Dual Layer)

NTSC : HLX-501 (Part No.: J-6090-071-A)

HLX-505 (Part No.: J-6090-089-A)

PAL : HLX-507 (Part No.: J-6090-078-A)

• Procedure to enter to DVD Service Mode:

1. Press **[I/⏻]** button to turn on the system.
2. Select DVD function.
3. Press **[■]** button and **[OPEN/CLOSE]** button simultaneously and then turn the **[VOLUME]** knob clockwise.
4. The message "SERVICE IN" appears on the fluorescent indicator tube and the Top Menu of Remocon Diagnosis Menu appears on the on-screen display on the TV. The model name and revision number is displayed at the bottom of the on-screen display.

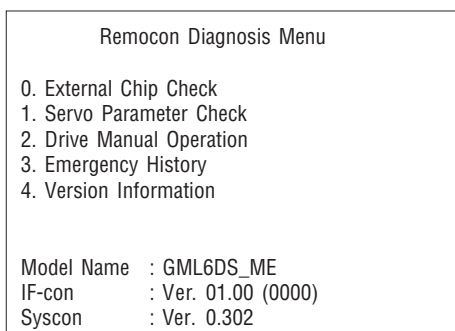

5. To execute each function, press its number by using numeric button on the remote commander.
6. To release from this mode, press **[I/⏻]** button to turn off the system.

• Execute IOP Measurement

In order to execute mirror time adjustment, the following standard procedures must be followed.

1. From the Top Menu of Remocon Diagnosis Menu, select "2. Drive Manual Operation" by pressing the **[2]** button on the remote commander. The following screen appears on the on-screen display.

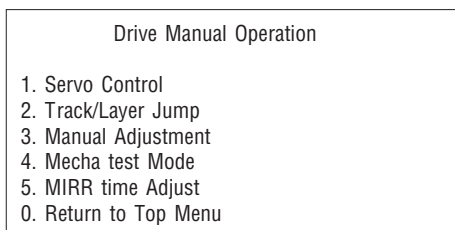

2. Select "3. Manual Adjustment" by pressing the **[3]** button on the remote commander. The following screen appears on the on-screen display.

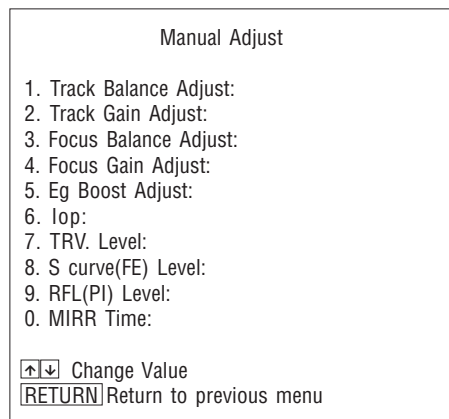

3. Select "6. Iop:" by pressing **[6]** button on the remote commander.
4. Wait until a hexadecimal number appears in the on-screen display as below:

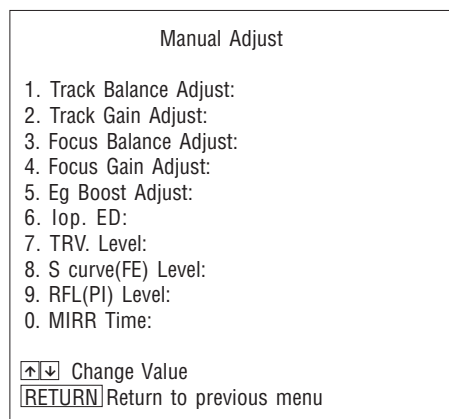

5. Convert data from hexadecimal to decimal by using conversion table.
6. Press **[RETURN]** button on the remote commander to return to previous menu.
7. Press **[0]** button on the remote commander to return to the Top Menu of Remocon Diagnosis Menu.
8. Press **[I/⏻]** button to turn off the system.

• Check Emergency History

To check the emergency history, please follow the following procedure.

1. From the Top Menu of Remocon Diagnosis Menu, select "3. Emergency History" by pressing the **[3]** button on the remote commander. The following screen appears on the on-screen display.

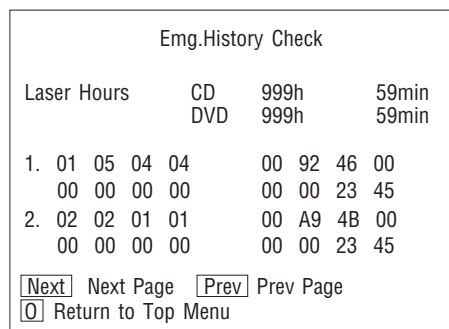

- You can check the total time when the laser is turned on during playback of DVD and CD from the above menu. The maximum time, which can be displayed are 999h 59min.
- You can check the error code of latest 10 emergency history from the above menu. To view the previous or next page of emergency history, press **◀** or **▶** on the remote commander. The error code consists of

- Error Code**

Example of Error code							
1.	01	05	04	04	00	92	46 00
	00	00	00	00	00	00	23 45

The meaning of error code is as below:

- 01: Communication error (No reply from syscon)
- 02: Syscon hung up
- 03: Power OFF request when syscon hung up
- 19: Thermal shutdown
- 24: MoveSledHome error
- 25: Mechanical move error (5 Changer)
- 26: Mechanical move stack error
- 30: DC motor adjustment error
- 31: DPD offset adjustment error
- 32: TE balance adjustment error
- 33: TE sensor adjustment error
- 34: TE loop gain adjustment error
- 35: FE loop gain adjustment error
- 36: Bad jitter after adjustment
- 40: Focus NG
- 42: Focus layer jump NG
- 52: Open kick spindle error
- 51: Spindle stop error
- 60: Focus on error
- 61: Seek fail error
- 62: Read Q data/ID error
- 70: Lead in data read fail
- 71: TOC read time out (CD)
- 80: Can't buffering
- 81: Unknown media type

- Parameter of error code**

This is the detail of error code.

Example of Error code							
1.	01	05	04	04	00	92	46 00
	00	00	00	00	00	00	23 45

- Time of error code**

This is the laser time when an error occurred.

Example of Error code							
1.	01	05	04	04	00	92	46 00
	00	00	00	00	00	00	23 45

To clear the Laser Hour

Press **DISPLAY** button and then press **CLEAR** button. The data for both CD and DVD data are reset.

Emg.History Check							
Laser Hours	CD	DVD	0h	0h	0min	0min	
1.	01	05	04	04	00	92	46 00
	00	00	00	00	00	00	23 45
2.	02	02	01	01	00	A9	4B 00
	00	00	00	00	00	00	23 45

Next Page
 Prev Page
 Return to Top Menu

To clear the Emergency History

Press **MENU** button and then press **CLEAR** button. The error code for all emergency history would be reset.

Emg.History Check							
Laser Hours	CD	DVD	999h	999h	59min	59min	
1.	00	00	00	00	00	00	00 00
	00	00	00	00	00	00	00 00
2.	00	00	00	00	00	00	00 00
	00	00	00	00	00	00	00 00

Next Page
 Prev Page
 Return to Top Menu

To return to the Top Menu of Remocon Diagnosis Menu

Press **0** button on the remote commander.

- Check Version Information**

To check the version information, please follow the following procedure.

- From the Top Menu of Remocon Diagnosis Menu, select "4. Version Information" by pressing the **4** button on the remote commander. The following screen appears on the on-screen display.

Version information	
Firm (Main) :	Ver. xxxxx
Firm (Sub) :	xxxxx
RISC :	xxxxx
8032 :	xxxxx
Audio DSP :	xxxxx
Servo DSP :	xxxxx

Return to Top Menu

To return to the Top Menu of Remocon Diagnosis Menu, press **0** on the remote commander.

SECTION 4 MECHANICAL ADJUSTMENTS

Precaution

1. Clean the following parts with a denatured alcohol-moistened swab:

record/playback heads	pinch rollers
erase head	rubber belts
capstan	idlers
2. Demagnetize the record/playback head with a head demagnetizer.
3. Do not use a magnetized screwdriver for the adjustments.
4. After the adjustments, apply suitable locking compound to the parts adjusted.
5. The adjustments should be performed with the rated power supply voltage unless otherwise noted.

Torque Measurement

Mode	Torque meter	Meter reading
FWD	CQ-102C	3.06 N • m to 6.96 N • m 31 to 71 g • cm (0.43 – 0.98 oz • inch)
FWD back tension	CQ-102C	0.19 N • m to 0.58 N • m 2 to 6 g • cm (0.02 – 0.08 oz • inch)
REV	CQ-102RC	3.06 N • m to 6.96 N • m 31 to 71 g • cm (0.43 – 0.98 oz • inch)
REV back tension	CQ-102RC	0.19 N • m to 0.58 N • m 2 to 6 g • cm (0.02 – 0.08 oz • inch)
FF/REW	CQ-201B	6.96 N • m to 14.02 N • m 71 to 143 g • cm (0.98 – 1.99 oz • inch)
FWD tension	CQ-403A	9.80 N • m 100 g or more (3.53 oz or more)
REV tension	CQ-403R	9.80 N • m 100 g or more (3.53 oz or more)

SECTION 5 ELECTRICAL ADJUSTMENTS

DVD SECTION

When the base unit is replaced, perform the adjustment and the measurement as shown below in this order.

- 1) MIRROR TIME ADJUSTMENT (See page 22)
- 2) EXECUTING IOP MEASUREMENT (See page 24)

[TEST DISC LIST]

Be sure to use the DVD disc that matches the signal standards of your region.

- CD
 - YEDS-18 (Part No.: 3-702-101-01)
 - PATD-012 (Part No.: 4-225-203-01)
- DVD SL (Single Layer)
 - NTSC : HLX-503 (Part No.: J-6090-069-A)
 - HLX-504 (Part No.: J-6090-088-A)
 - PAL : HLX-506 (Part No.: J-6090-077-A)
- DVD DL (Dual Layer)
 - NTSC : HLX-501 (Part No.: J-6090-071-A)
 - HLX-505 (Part No.: J-6090-089-A)
 - PAL : HLX-507 (Part No.: J-6090-078-A)

[RFMON Level Check]

Connection:

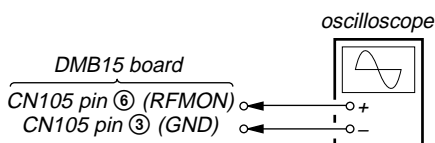

Procedure:

1. Connect an oscilloscope to CN105 pin ⑥ (RFMON) and CN105 pin ③ (GND) on the DMB15 board.
2. Turn the power on.
3. Set the test disc (refer to the TEST DISC LIST) on the tray and press button to playback.
4. Confirm that oscilloscope waveform is clear and check RFMON signal level is correct or not.

Note: A clear RFMON signal waveform means that the shape “∩” can be clearly distinguished at the center of the waveform.

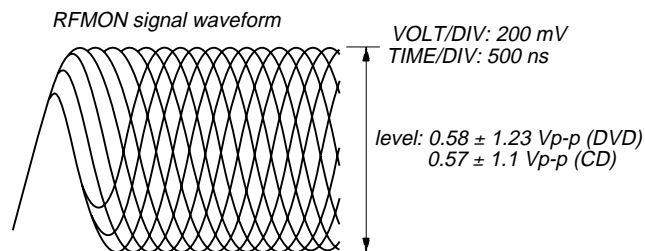

Checking Location: DMB15 board (Side A)

【DMB15 BOARD】(SIDE A)

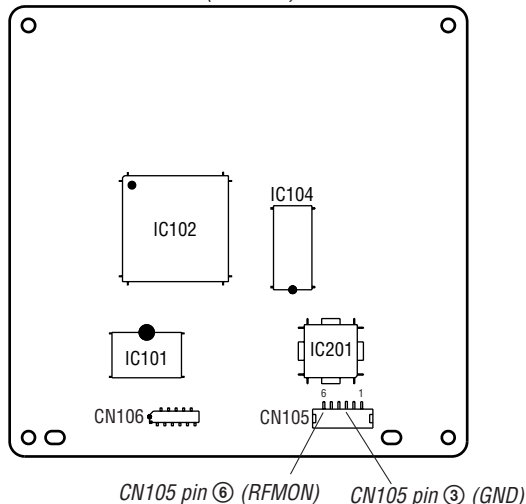

VIDEO SECTION

Video Level Check (VIDEO BOARD)

Purpose

This adjustment is made to satisfy the NTSC standard, and if not adjusted correctly, the brightness will be too large or small.

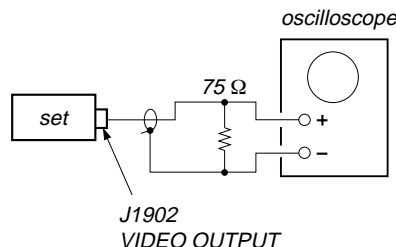

Procedure:

1. Connect oscilloscope to VIDEO output.
2. Load a DVD reference disc playback.
3. Check the video signal level is $1.00 \pm 0.07 V_{p-p}$.



DECK SECTION

0 dB=0.775 V

1. Demagnetize the record/playback head with a head demagnetizer.
2. Do not use a magnetized screwdriver for the adjustments.
3. After the adjustments, apply suitable locking compound to the parts adjust.
4. The adjustments should be performed with the rated power supply voltage unless otherwise noted.
5. The adjustments should be performed in the order given in this service manual. (As a general rule, playback circuit adjustment should be completed before performing recording circuit adjustment.)
6. The adjustments should be performed for both L-CH and R-CH.
7. Switches and controls should be set as follows unless otherwise specified.

• Test Tape

Tape	Signal	Used for
P-4-A063	6.3 kHz, -10 dB	Azimuth Adjustment

Record/Playback Head Azimuth Adjustment

DECK A

DECK B

Note: Perform this adjustments for both decks

Procedure:

1. Mode: Playback

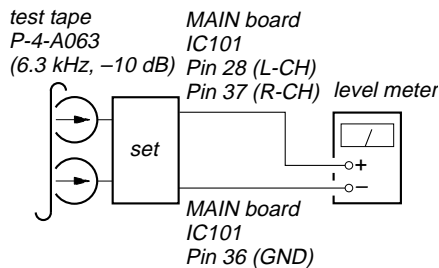

2. Turn the adjustment screw and check output peaks. If the peaks do not match for L-CH and R-CH, turn the adjustment screw so that outputs match within 1dB of peak.

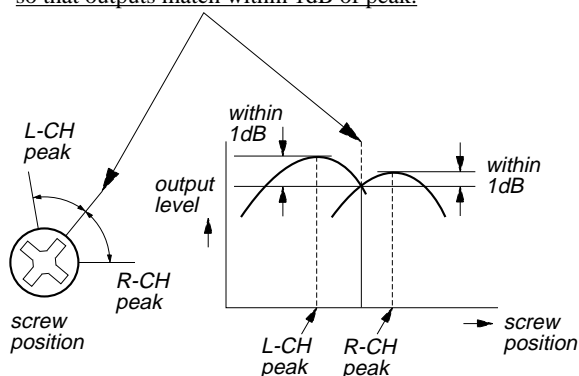

3. Mode: Playback

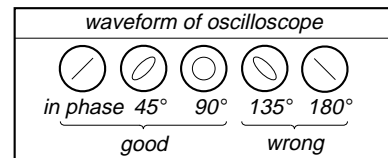
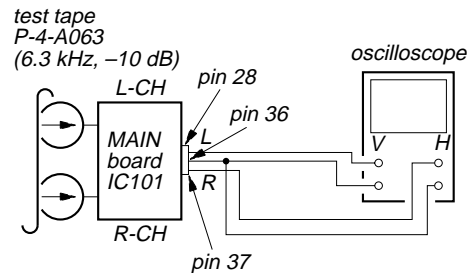

4. After the adjustments, apply suitable locking compound to the parts adjusted.

Adjustment Location: Playback Head (Deck A).

Record/Playback/Erase Head (Deck B).

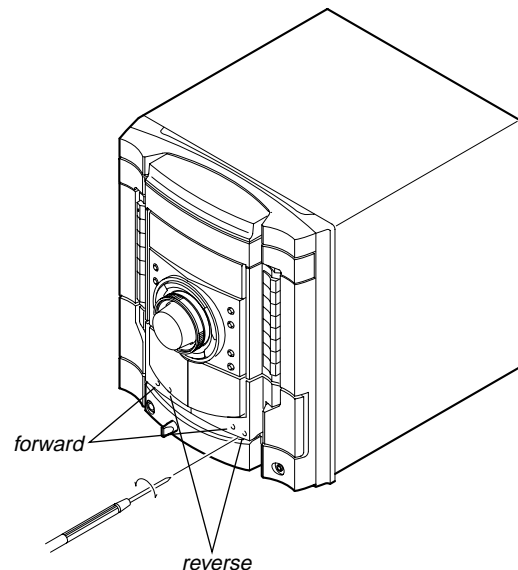

MEMO

SECTION 6 DIAGRAMS

6-1. BLOCK DIAGRAM — RF/SERVO SECTION —

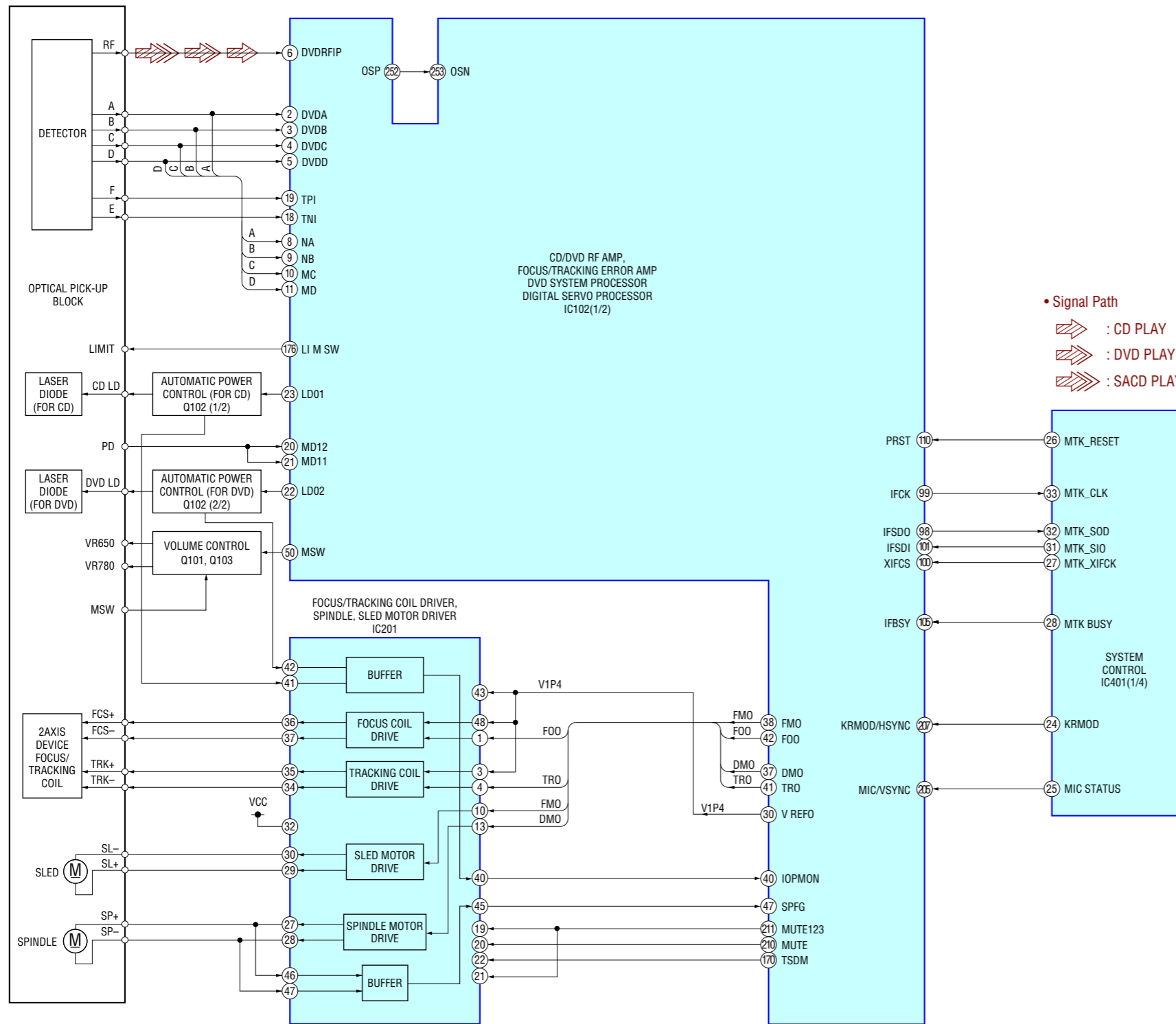

6-2. BLOCK DIAGRAM — VIDEO SECTION —

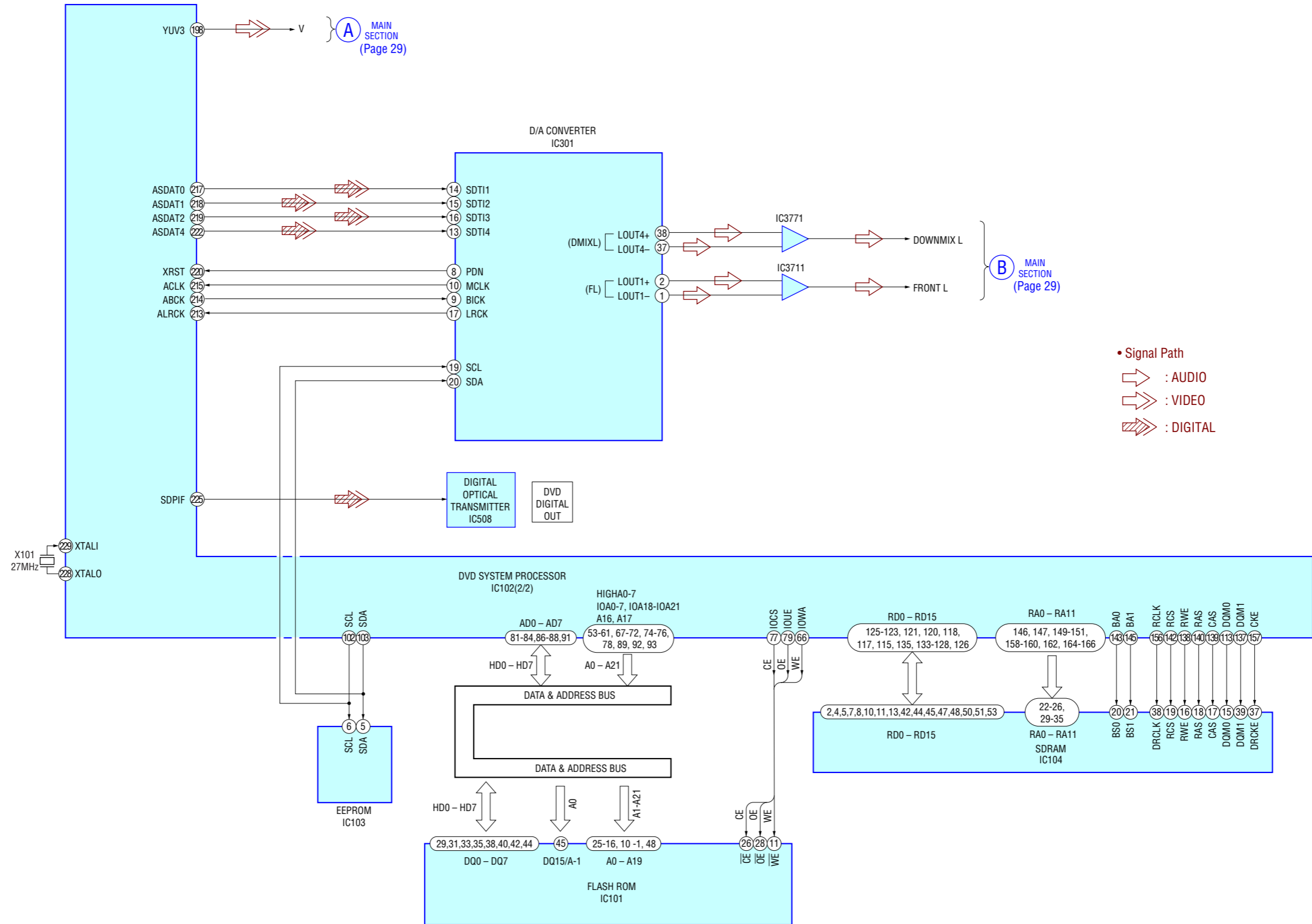

6-3. BLOCK DIAGRAM — MAIN SECTION —

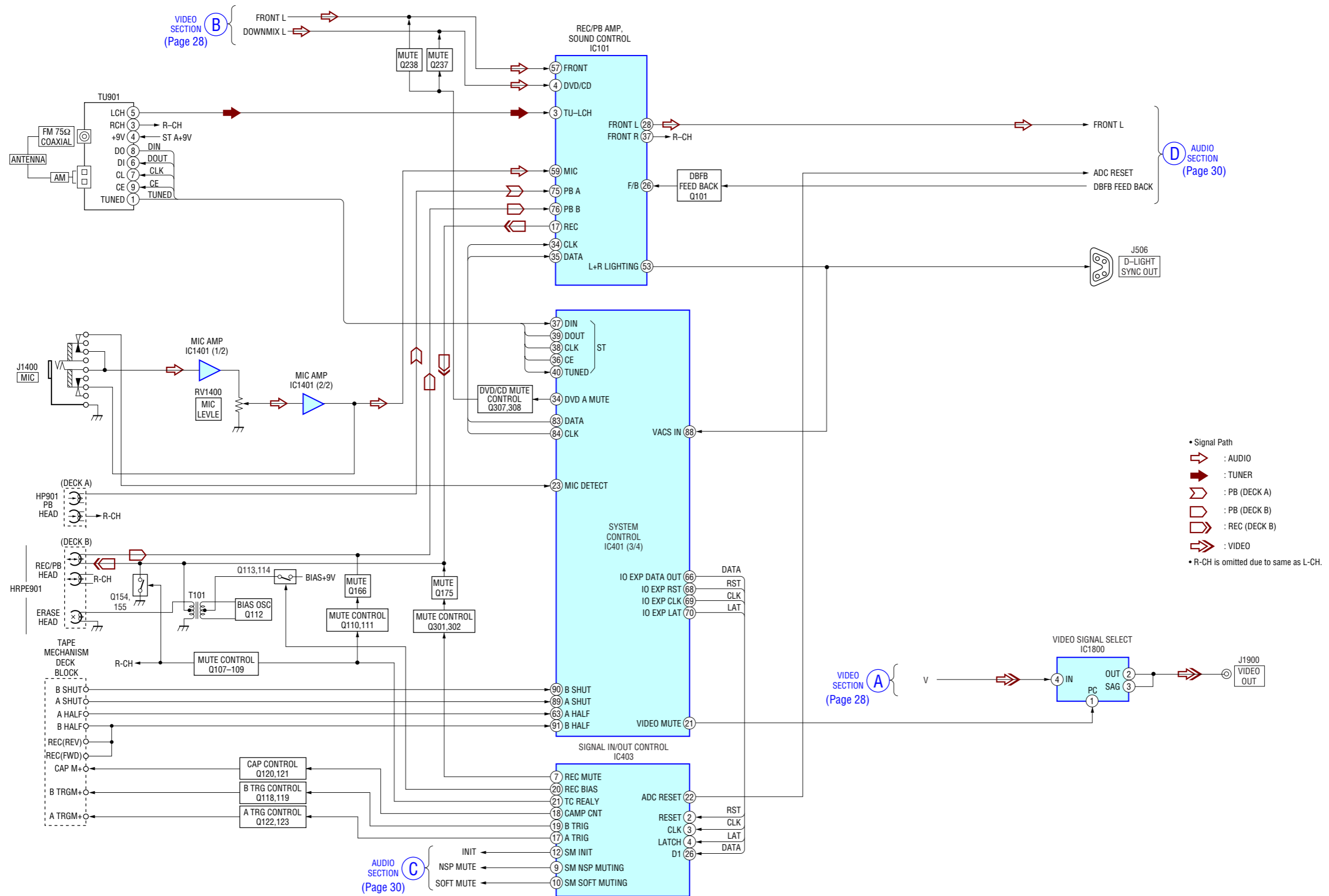

6-4. BLOCK DIAGRAM — AUDIO SECTION —

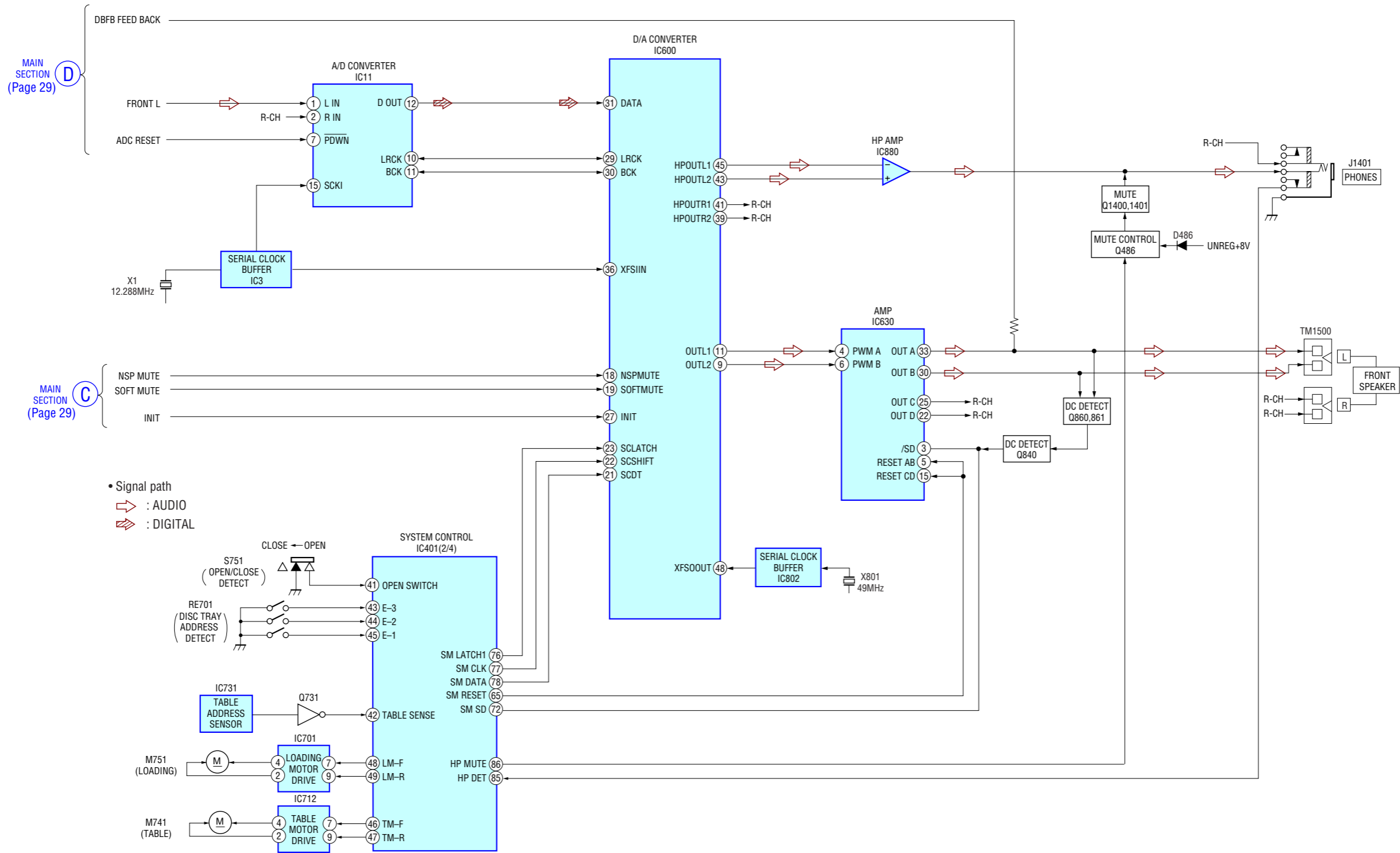

6-5. BLOCK DIAGRAM — FUNCTION/POWER SECTION —

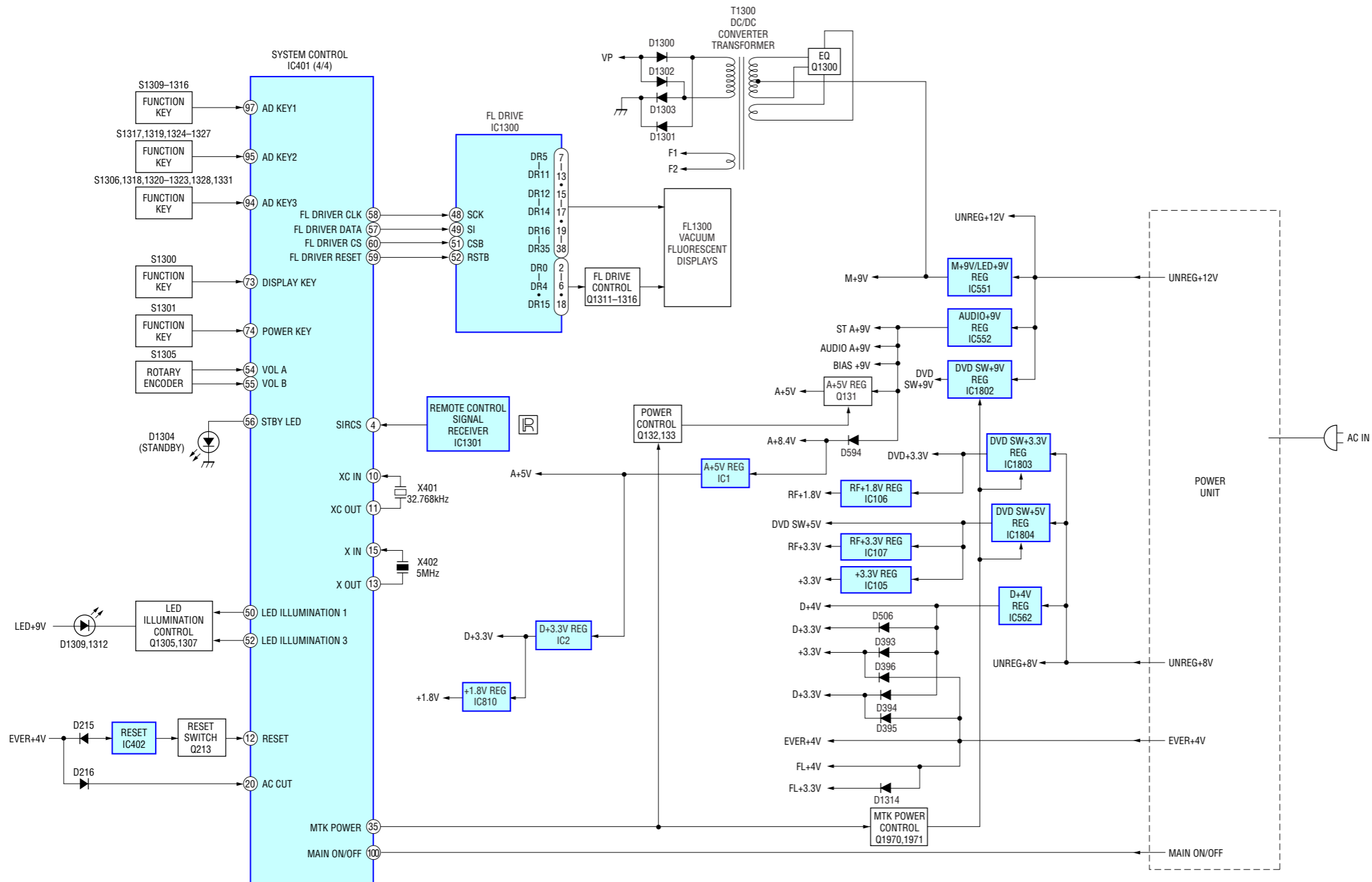

6-6. CIRCUIT BOARDS LOCATION

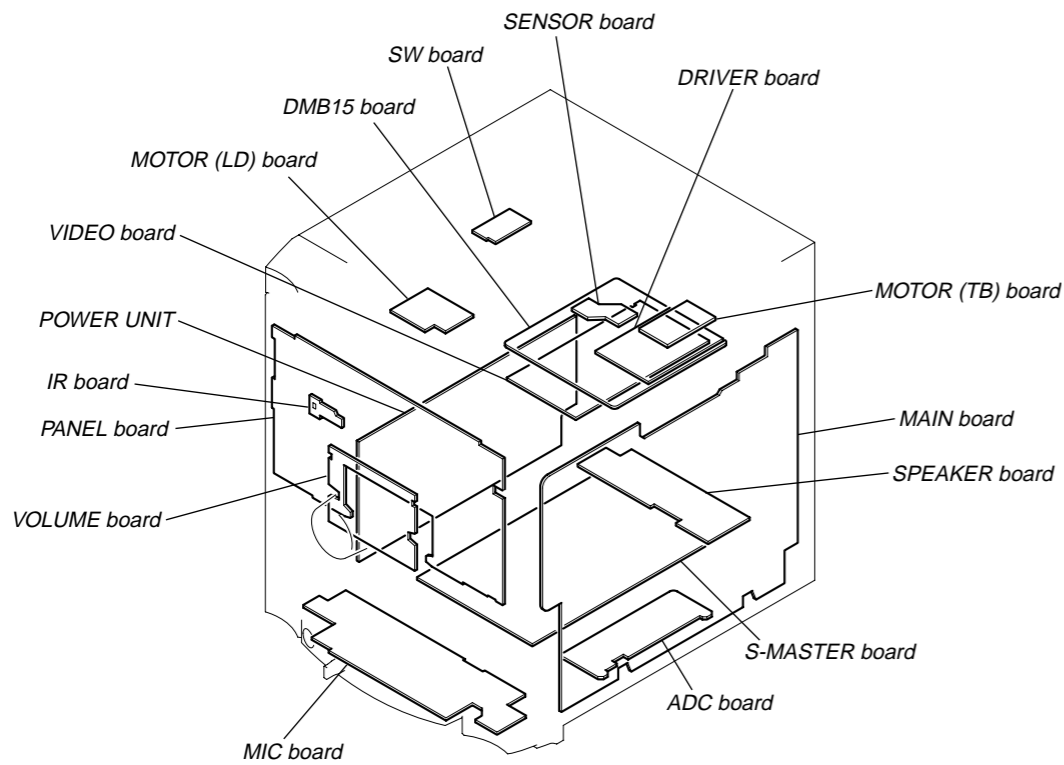

• Note For Printed Wiring Boards And Schematic Diagrams

Note on Printed Wiring Board:

- : parts extracted from the component side.
- : parts extracted from the conductor side.
- : Pattern from the side which enables seeing. (The other layer's patterns are not indicated.)

Caution:
 Pattern face side: Parts on the pattern face side seen from (Conductor Side) the pattern face are indicated.
 Parts face side: Parts on the parts face side seen from (Component Side) the parts face are indicated.

- Indication of transistor.

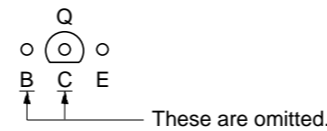
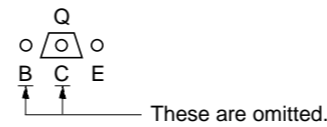
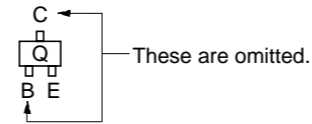

UNLEADED SOLDER

Boards requiring use of unleaded solder are printed with the lead free mark (LF) indicating the solder contains no lead. (Caution: Some printed circuit boards may not come printed with the lead free mark due to their particular size)

LF : LEAD FREE MARK

Unleaded solder has the following characteristics.

- Unleaded solder melts at a temperature about 40 °C higher than ordinary solder.
 Ordinary soldering irons can be used but the iron tip has to be applied to the solder joint for a slightly longer time.
 Soldering irons using a temperature regulator should be set to about 350 °C.
 Caution: The printed pattern (copper foil) may peel away if the heated tip is applied for too long, so be careful!
- Strong viscosity
 Unleaded solder is more viscous (sticky, less prone to flow) than ordinary solder so use caution not to let solder bridges occur such as on IC pins, etc.
- Usable with ordinary solder
 It is best to use only unleaded solder but unleaded solder may also be added to ordinary solder.

Note on Schematic Diagram:

- All capacitors are in μF unless otherwise noted. (p: pF) 50 WV or less are not indicated except for electrolytics and tantalums.
- All resistors are in Ω and $1/4\text{ W}$ or less unless otherwise specified.
- : nonflammable resistor.
- : panel designation.

Note: The components identified by mark \triangle or dotted line with mark \triangle are critical for safety. Replace only with part number specified.

- : B+ Line.
- : B- Line.
- Voltage and waveforms are dc with respect to ground under no-signal (detuned) conditions.
 no mark : FM
 * : Impossible to measure
- Voltages are taken with a VOM (Input impedance 10 M Ω). Voltage variations may be noted due to normal production tolerances.
- Waveforms are taken with an oscilloscope. Voltage variations may be noted due to normal production tolerances.
- Circled numbers refer to waveforms.
- Signal path.
 : AUDIO
 : TUNER
 : VIDEO (COMPONENT)
 : VIDEO (COMPOSITE)
 : TAPE PLAY (DECK A)
 : TAPE PLAY (DECK B)
 : TAPE REC (DECK B)
 : DVD (AUDIO)
 : DVD (RF)
 : DVD (DIGITAL)
- Abbreviation
 E3 : 240 V AC area in E model
 E12 : 220-240 V AC area in E model
 E13 : 220-230 V AC area in E model
 E15 : Iran model
 EA : Saudi arabia model
 MY : Malaysia model
 PH : Philippine model
 SP : Singapore model
 TH : Thai model

• Waveforms

— DMB15 BOARD —

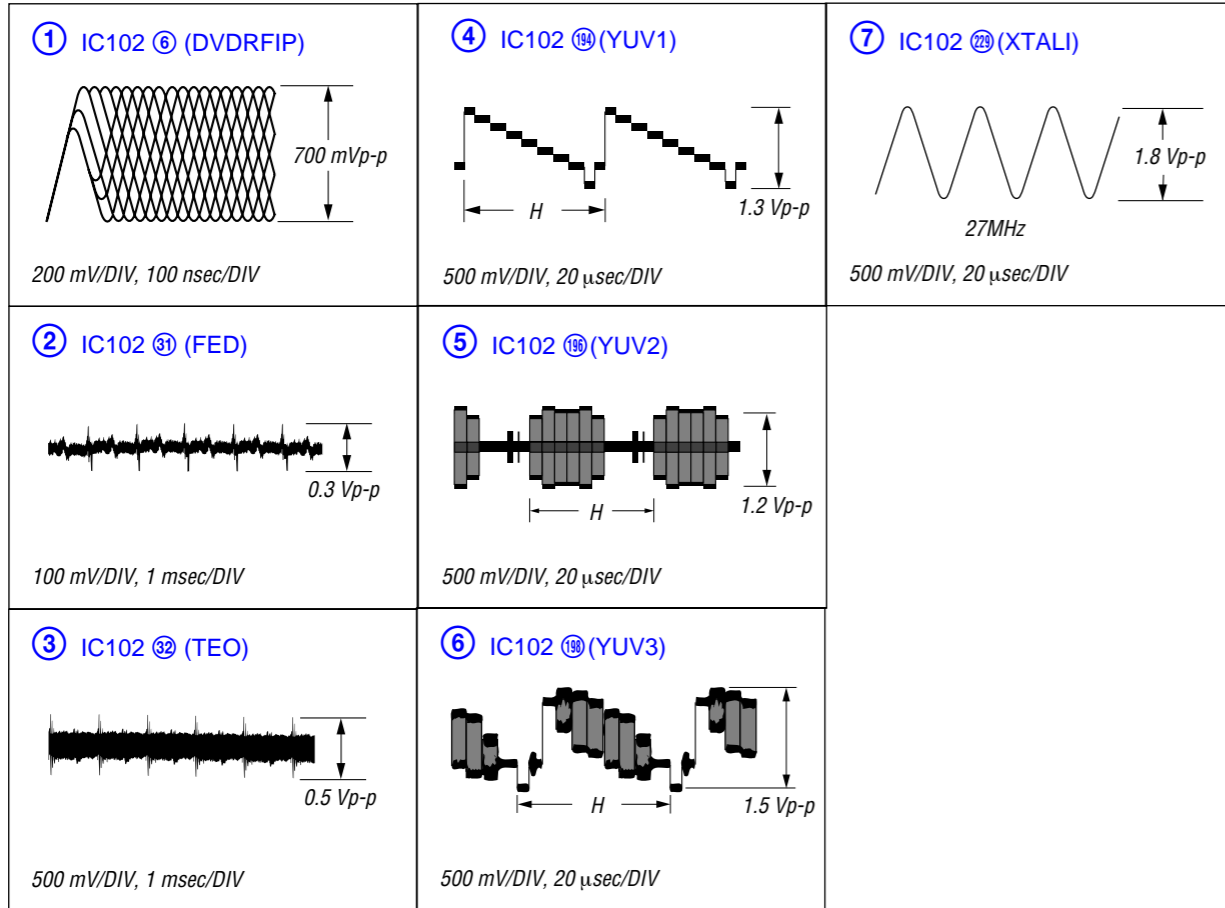

— S-MASTER BOARD —

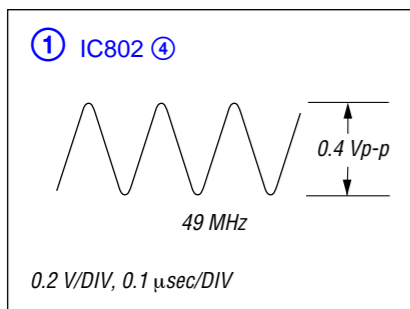

— MAIN BOARD —

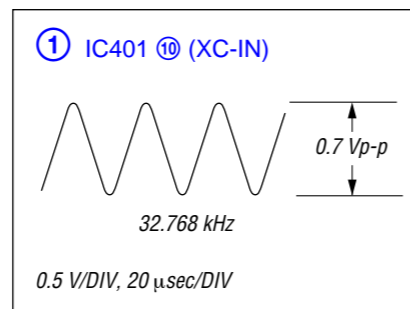

— ADC BOARD —

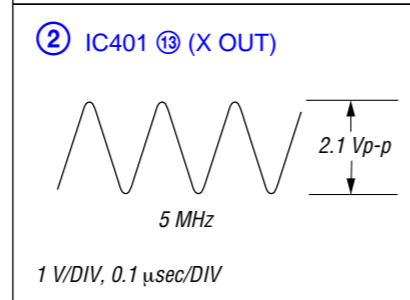
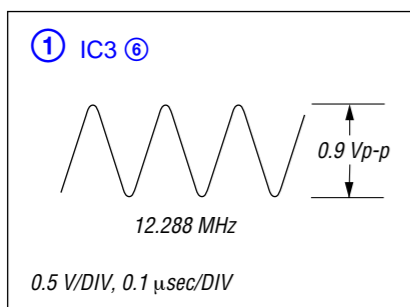

6-7. PRINTED WIRING BOARDS — DRIVER SECTION — • Refer to page 32 for Circuit Boards Location.  : Uses unleaded solder.

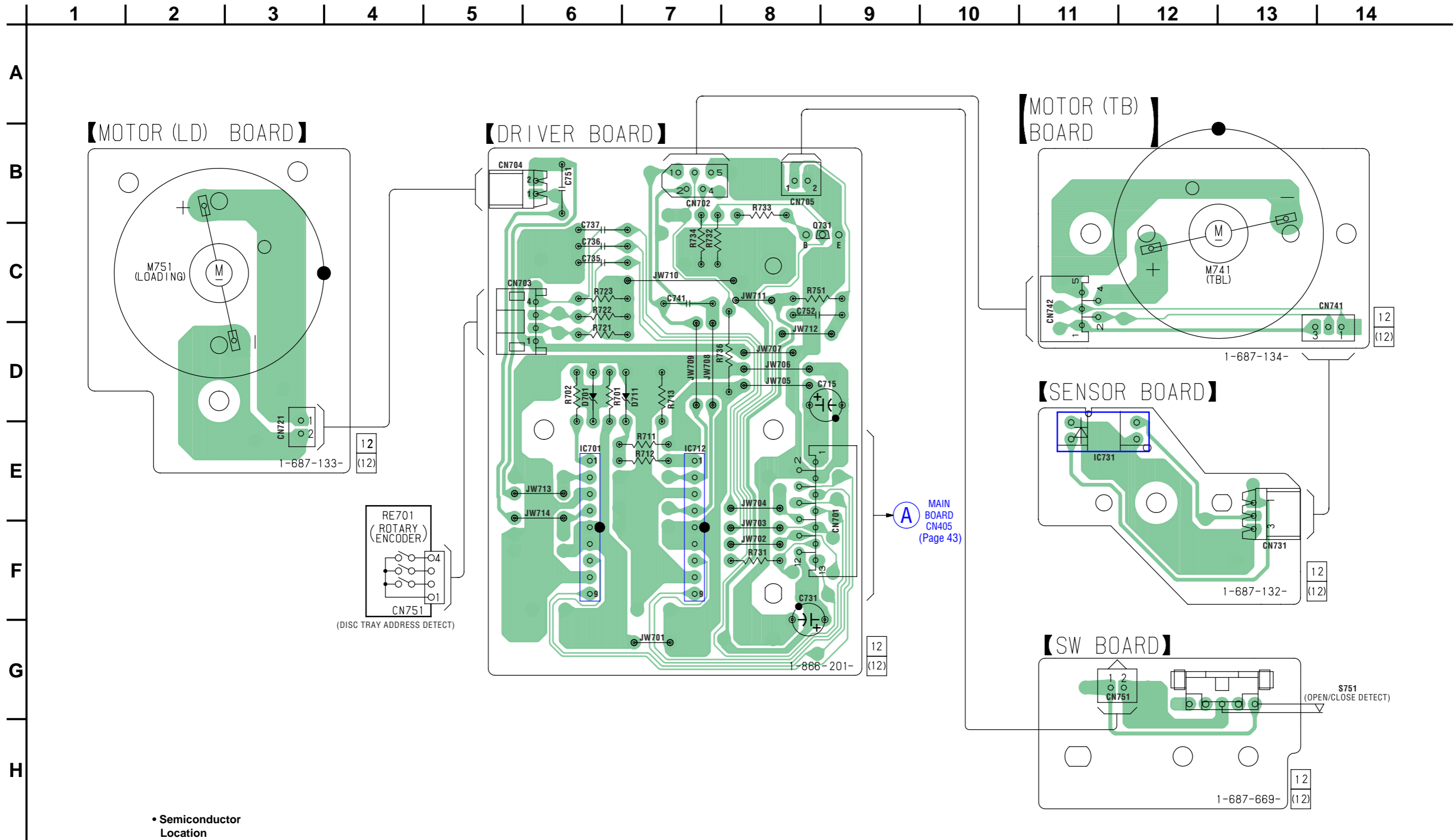

• Semiconductor Location

Ref. No.	Location
D701	D-6
D711	D-7
IC701	E-6
IC712	E-7
IC731	E-11
Q731	B-8

6-8. SCHEMATIC DIAGRAM — DRIVER SECTION — • Refer to page 63 for IC Block Diagrams.

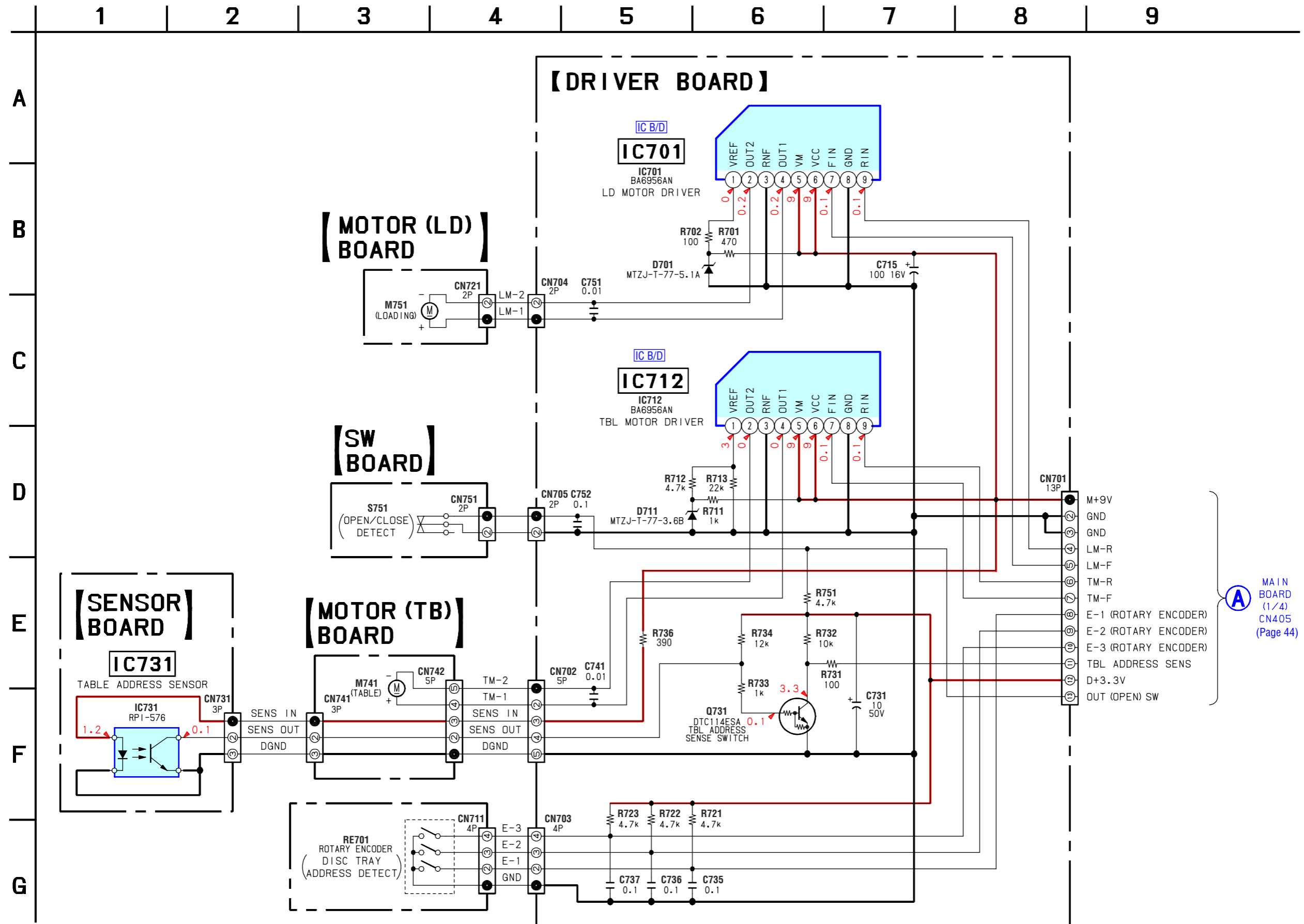

A MAIN BOARD (1/4) CN405 (Page 44)

6-9. PRINTED WIRING BOARD — DMB15 SECTION — • Refer to page 32 for Circuit Boards Location.  : Uses unleaded solder.

☆ New part of EEPROM (IC103) on the DMB15 board cannot be used. Therefore, if the mounted DMB15 board (A-1167-778-A, etc.) is replaced, exchange new EEPROM (IC103) with that used before the replacement.

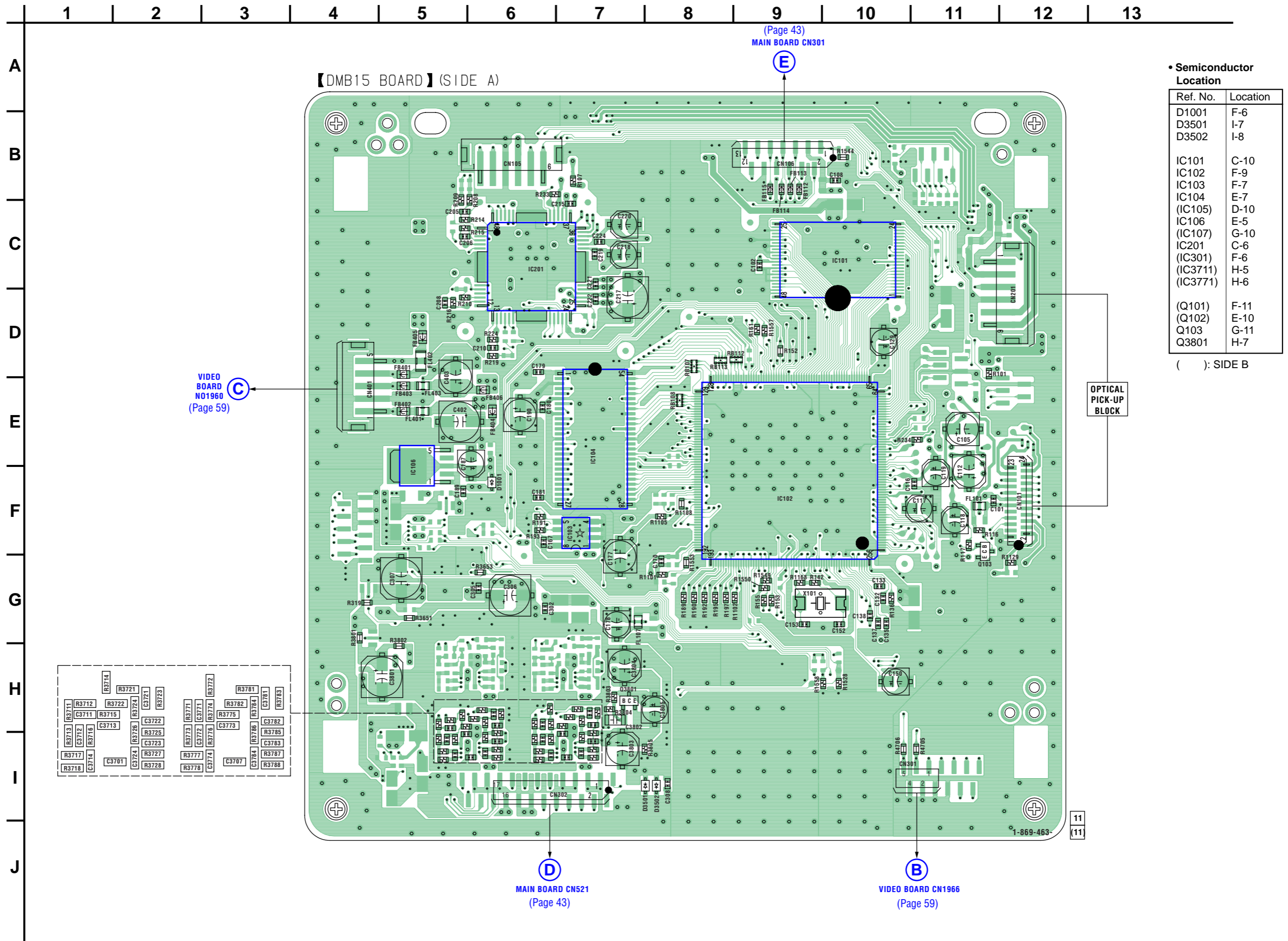

• Semiconductor Location

Ref. No.	Location
D1001	F-6
D3501	I-7
D3502	I-8
IC101	C-10
IC102	F-9
IC103	F-7
IC104	E-7
(IC105)	D-10
IC106	E-5
(IC107)	G-10
IC201	C-6
(IC301)	F-6
(IC3711)	H-5
(IC3771)	H-6
(Q101)	F-11
(Q102)	E-10
Q103	G-11
Q3801	H-7

() : SIDE B

R3714	R3721	R3723	R3781	R3783
R3711	R3712	R3722	R3724	R3725
R3713	R3715	R3726	R3727	R3728
R3717	R3718	R3719	R3720	R3721
R3722	R3723	R3724	R3725	R3726
R3727	R3728	R3729	R3730	R3731
R3732	R3733	R3734	R3735	R3736
R3737	R3738	R3739	R3740	R3741
R3742	R3743	R3744	R3745	R3746
R3747	R3748	R3749	R3750	R3751
R3752	R3753	R3754	R3755	R3756
R3757	R3758	R3759	R3760	R3761
R3762	R3763	R3764	R3765	R3766
R3767	R3768	R3769	R3770	R3771
R3772	R3773	R3774	R3775	R3776
R3777	R3778	R3779	R3780	R3781
R3782	R3783	R3784	R3785	R3786
R3787	R3788	R3789	R3790	R3791
R3792	R3793	R3794	R3795	R3796
R3797	R3798	R3799	R3800	R3801

6-11. SCHEMATIC DIAGRAM — DMB15 SECTION (2/5) — • Refer to page 63 for IC Block Diagrams.

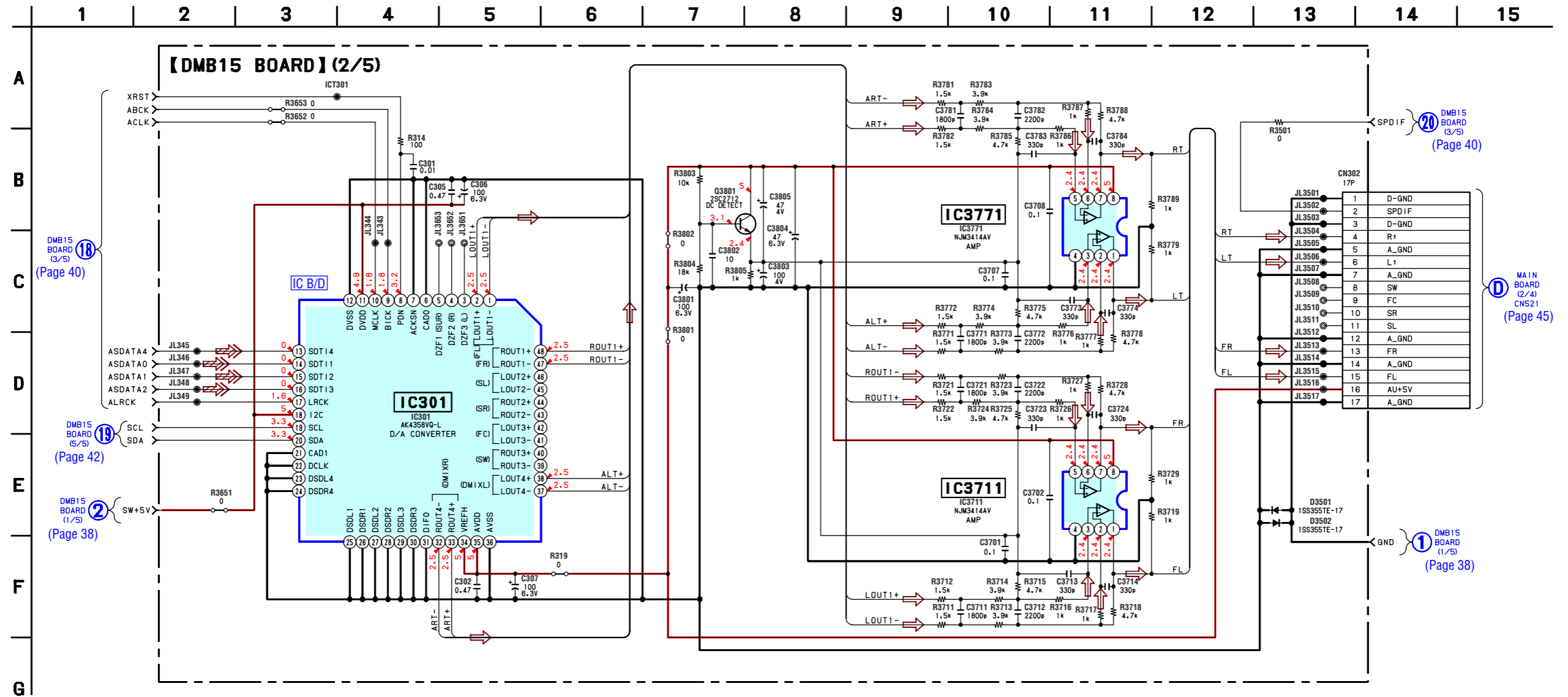

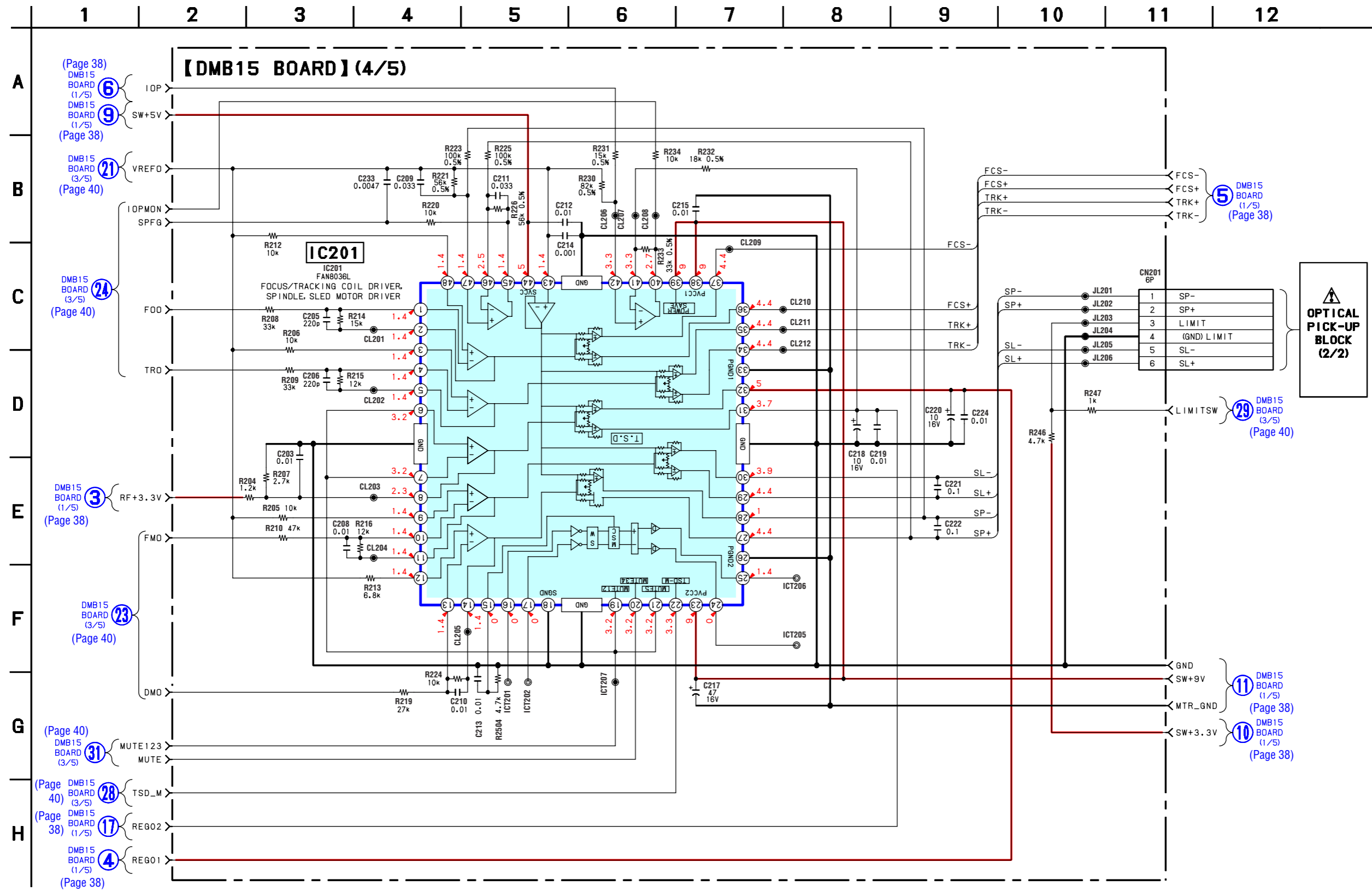

6-13. SCHEMATIC DIAGRAM — DMB15 SECTION (4/5) —

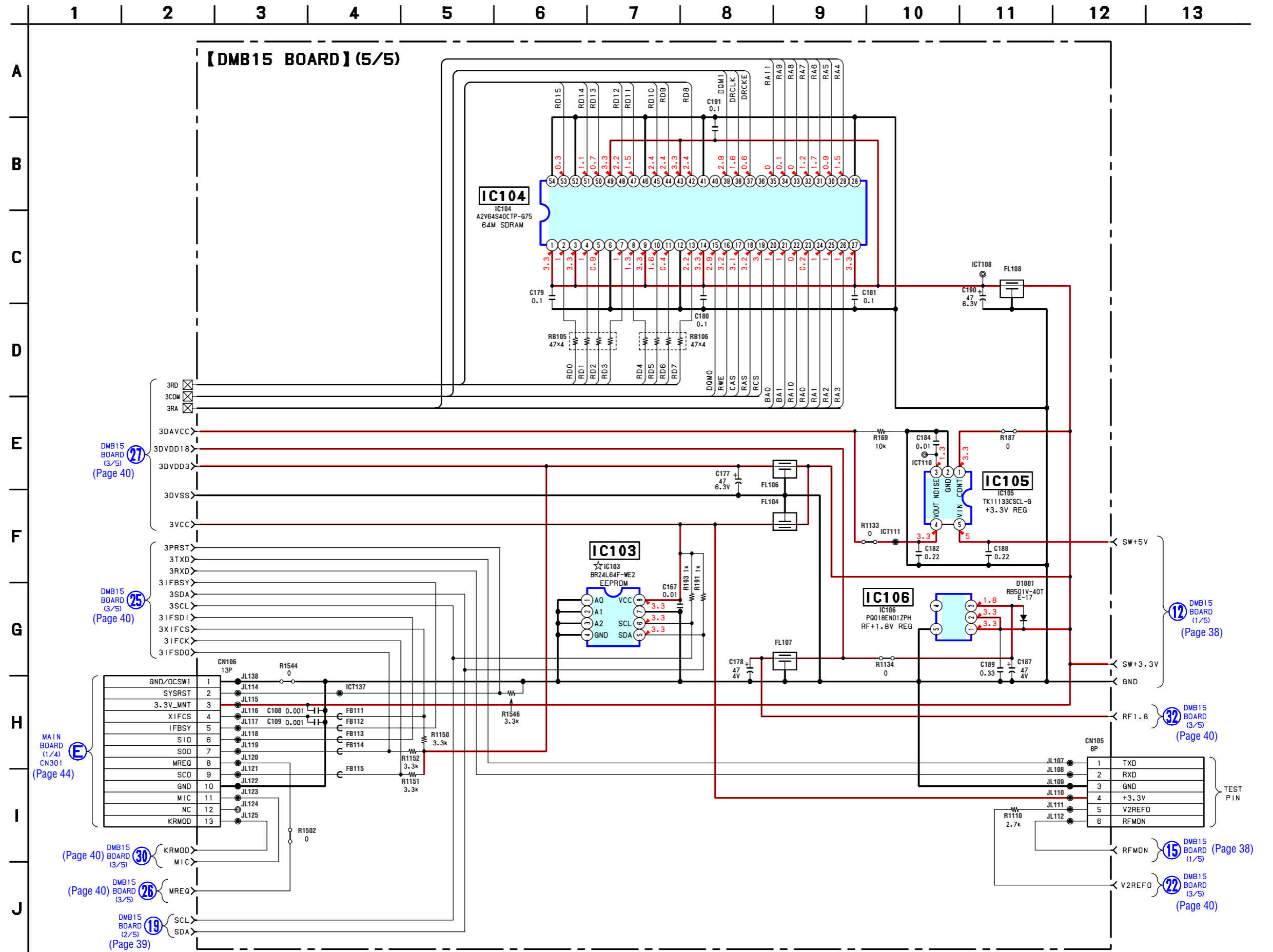

☆ New part of EEPROM (IC103) on the DMB15 board cannot be used. Therefore, if the mounted DMB15 board (A-1167-778-A, etc.) is replaced, exchange new EEPROM (IC103) with that used before the replacement.

6-14. SCHEMATIC DIAGRAM — DMB15 SECTION (5/5) —



6-15. PRINTED WIRING BOARD — MAIN SECTION — • Refer to page 32 for Circuit Boards Location.  : Uses unleaded solder.

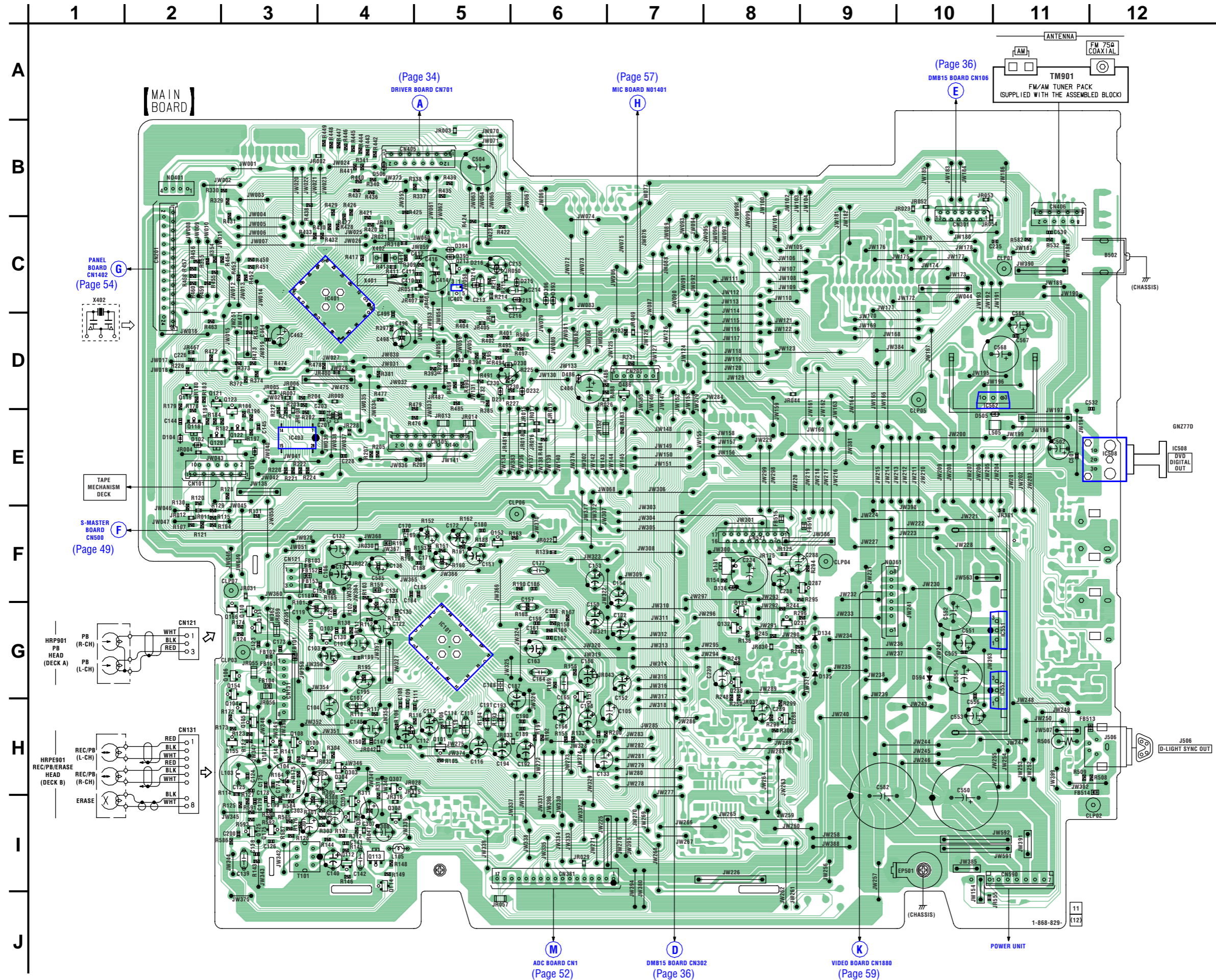

• Semiconductor Location

Ref. No.	Location
D101	E-3
D102	E-2
D104	E-2
D134	G-9
D135	G-9
D136	F-8
D213	C-6
D214	C-5
D215	C-6
D216	C-5
D230	D-5
D231	D-5
D232	D-6
D393	C-6
D394	C-5
D395	C-5
D396	C-6
D486	D-6
D505	E-10
D506	B-4
D583	G-11
D594	G-10
IC101	G-5
IC401	C-4
IC402	C-5
IC403	E-3
IC508	E-12
IC551	G-11
IC552	G-11
IC562	D-10
Q101	H-5
Q103	G-4
Q104	H-3
Q105	H-3
Q106	G-3
Q107	H-3
Q108	H-3
Q109	H-3
Q110	G-3
Q111	G-3
Q112	I-4
Q113	I-4
Q114	I-4
Q118	E-2
Q119	D-2
Q120	E-2
Q122	E-3
Q123	E-3
Q125	I-3
Q131	F-8
Q132	G-8
Q133	G-8
Q151	G-6
Q153	F-5
Q154	G-3
Q155	H-3
Q166	G-3
Q175	I-3
Q213	C-5
Q237	G-8
Q238	G-8
Q287	F-9
Q288	H-8
Q301	I-4
Q302	I-4
Q303	H-4
Q304	H-4
Q307	H-4
Q308	I-4
Q486	D-7
Q584	G-12

• Refer to page 33 for Waveforms.

6-16. SCHEMATIC DIAGRAM — MAIN SECTION (1/4) — • Refer to page 71 for IC Pin Description of IC401.

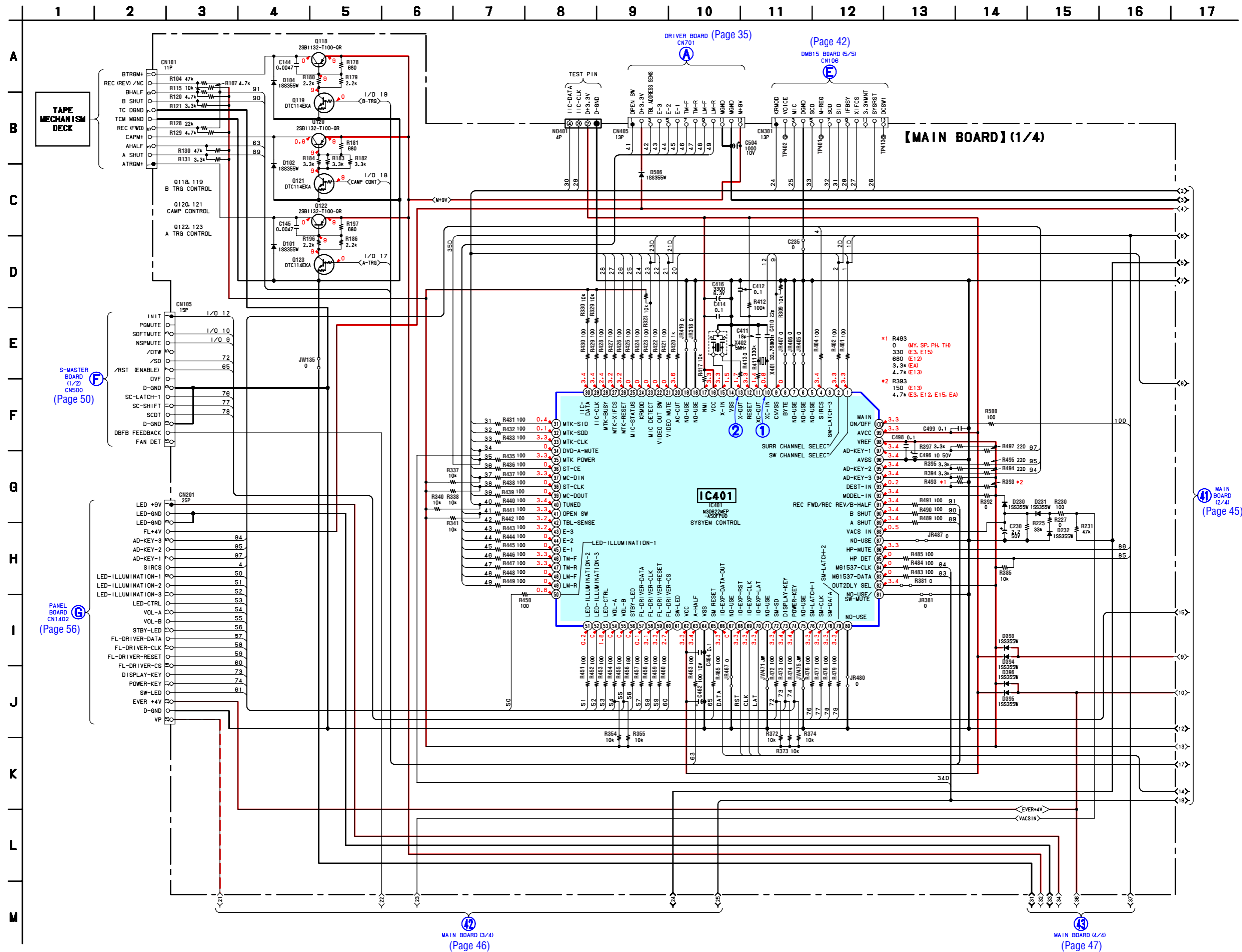

6-18. SCHEMATIC DIAGRAM — MAIN SECTION (3/4) —

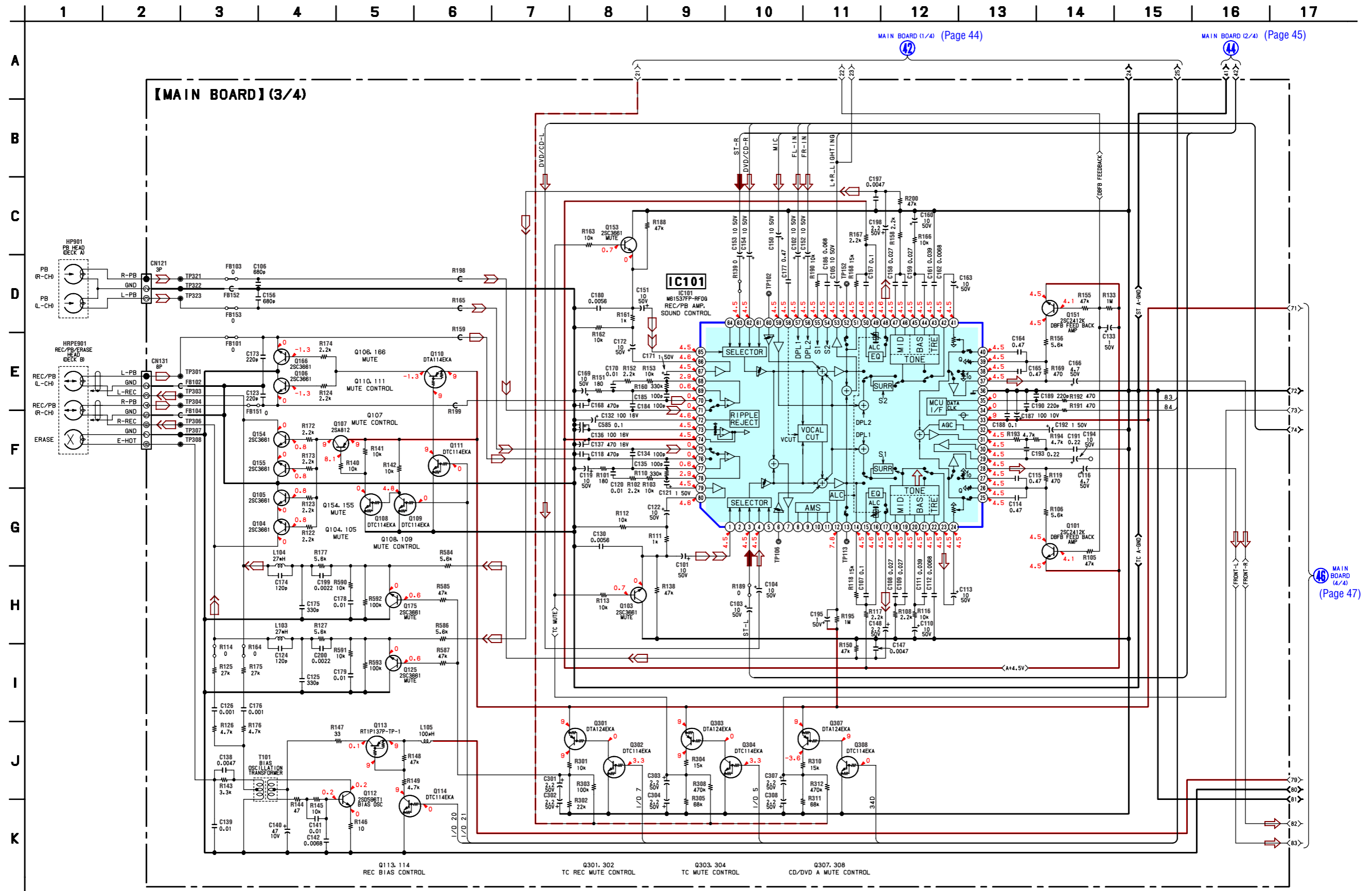

6-19. SCHEMATIC DIAGRAM — MAIN SECTION (4/4) —

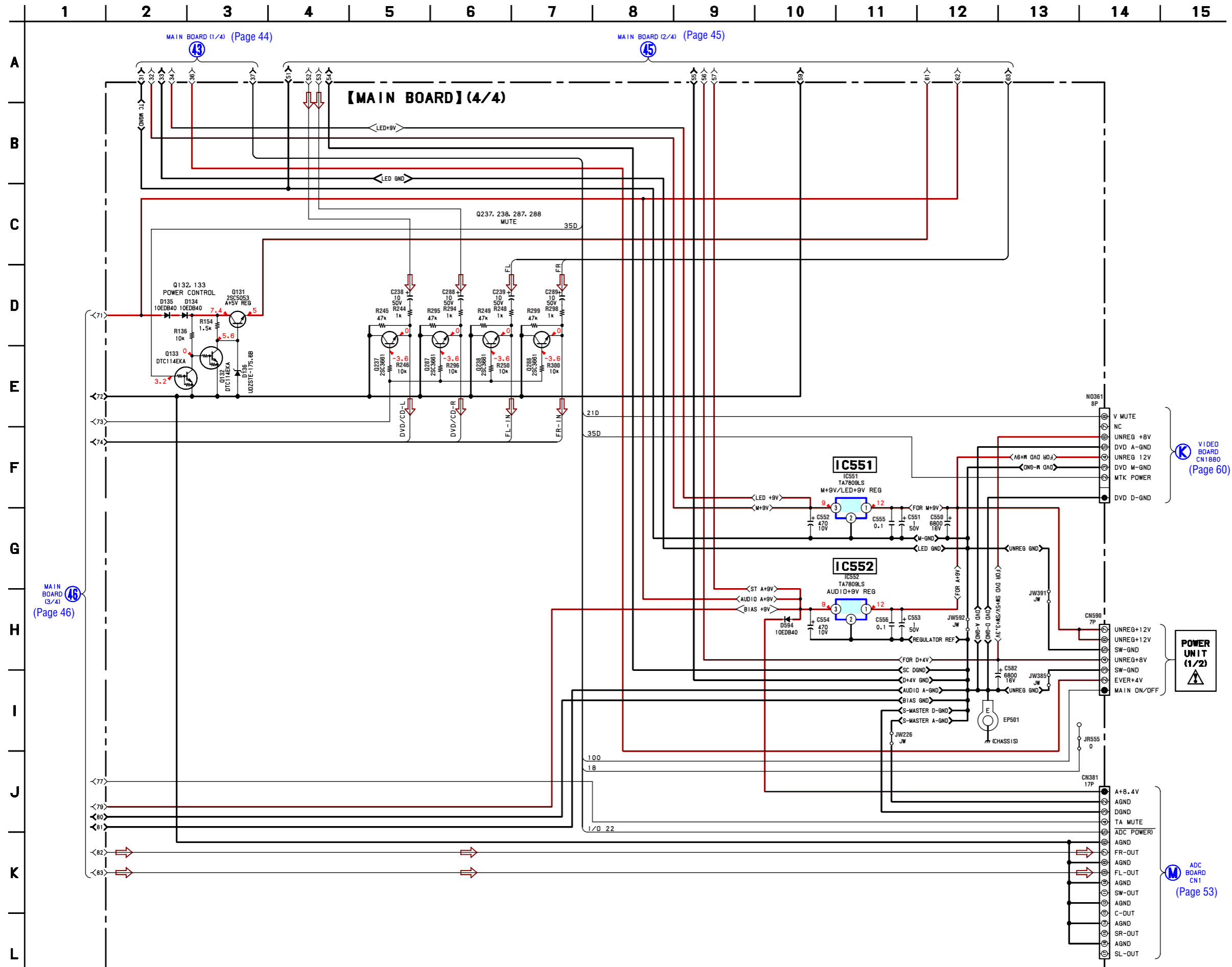

6-20. PRINTED WIRING BOARD — S-MASTER SECTION — • Refer to page 32 for Circuit Boards Location.  : Uses unleaded solder.

12 | 11 | 10 | 9 | 8 | 7 | 6 | 5 | 4 | 3 | 2 | 1

【S-MASTER BOARD】(SIDE A)

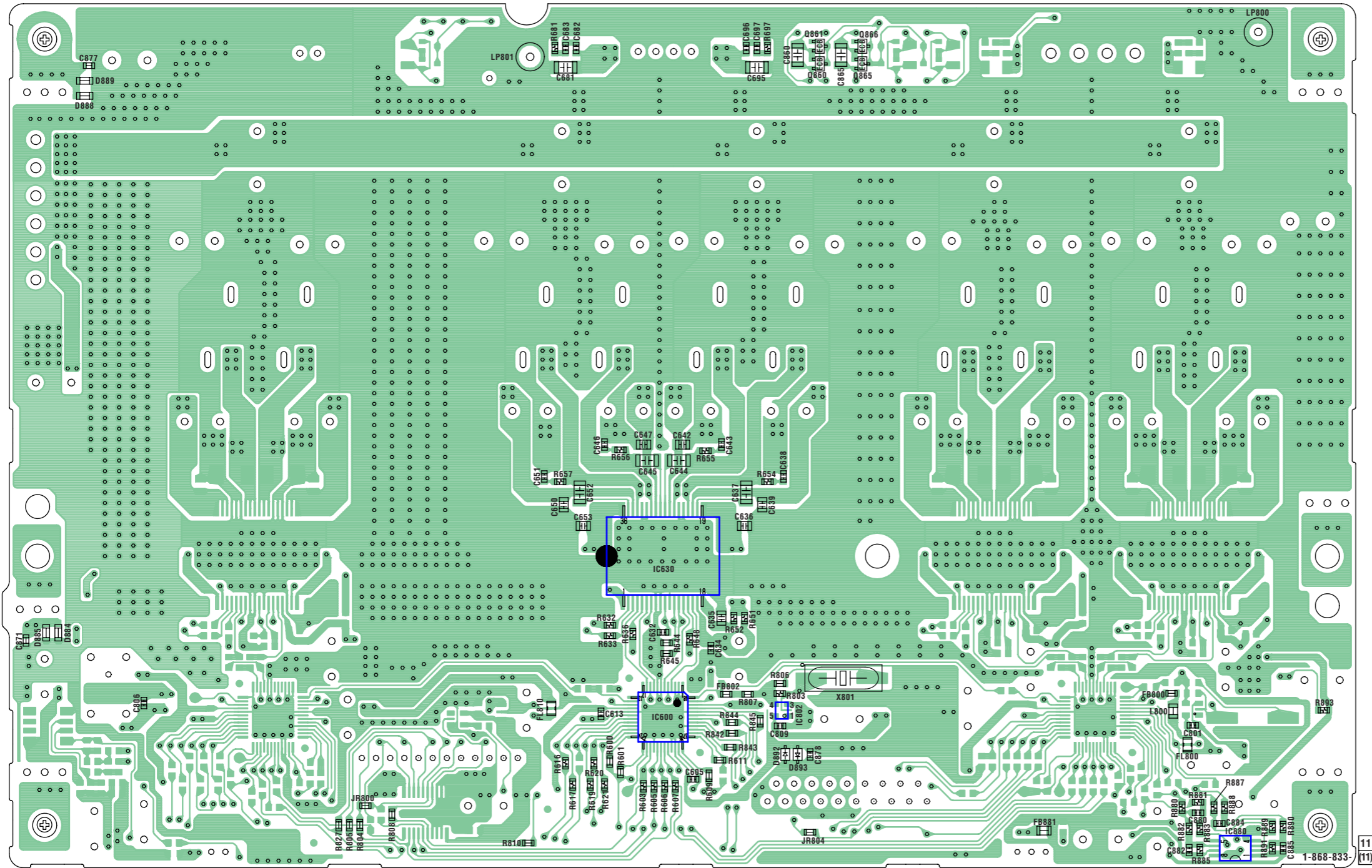

• Semiconductor Location

Ref. No.	Location
(D651)	E-7
(D652)	F-7
(D653)	F-7
(D654)	E-7
(D820)	C-2
(D880)	H-12
(D881)	H-12
(D882)	H-1
(D883)	H-1
D892	H-6
D893	H-6
IC600	G-7
IC630	F-7
IC802	G-6
(IC810)	G-12
IC880	H-2
(Q840)	B-8
Q860	B-6
Q861	B-6
Q865	B-5
Q866	B-5

() : SIDE B

A
B
C
D
E
F
G
H
I

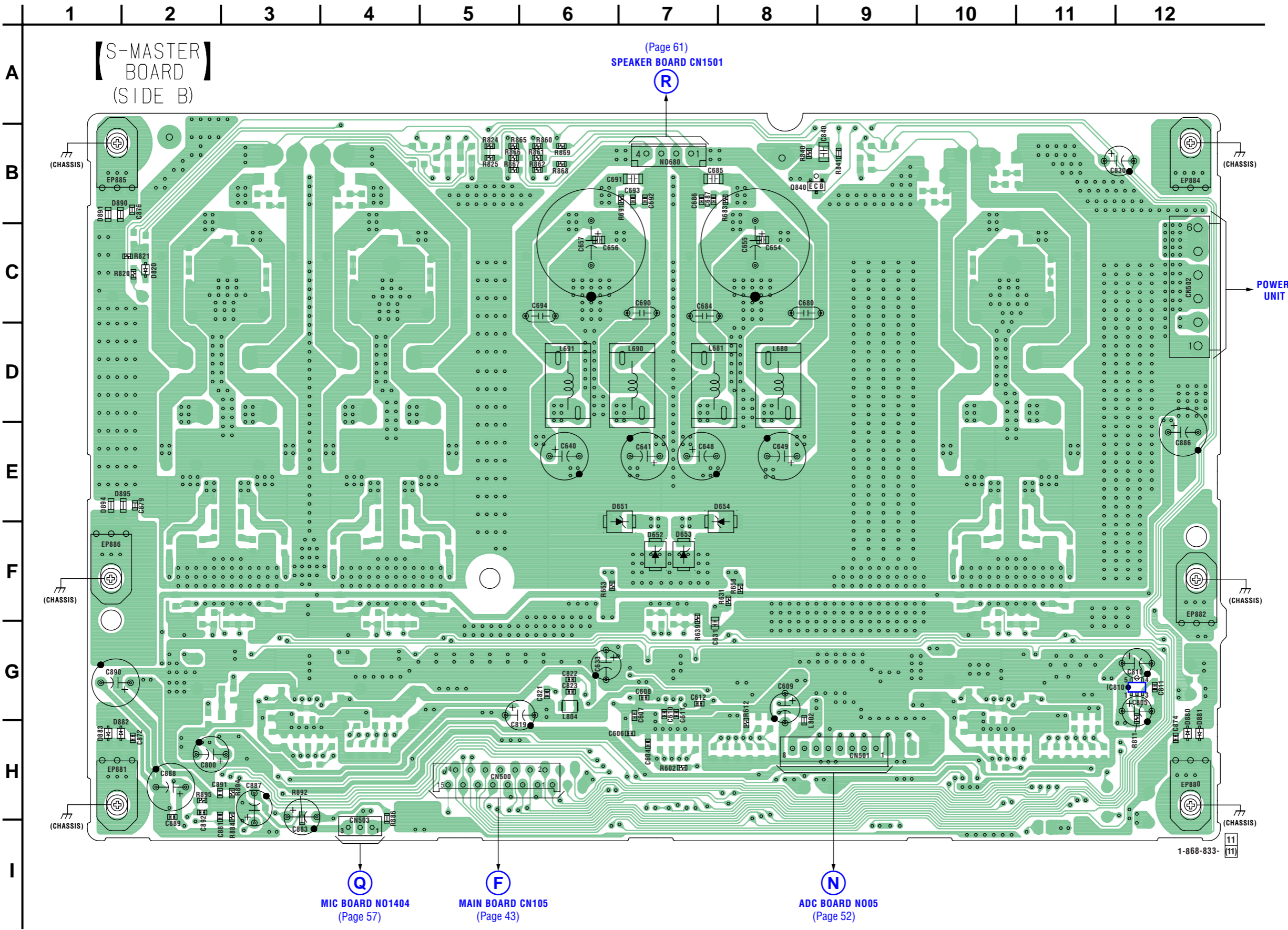

• Refer to page 33 for Waveforms.

6-21. SCHEMATIC DIAGRAM — S-MASTER SECTION (1/2) — • Refer to page 64 for IC Block Diagrams.

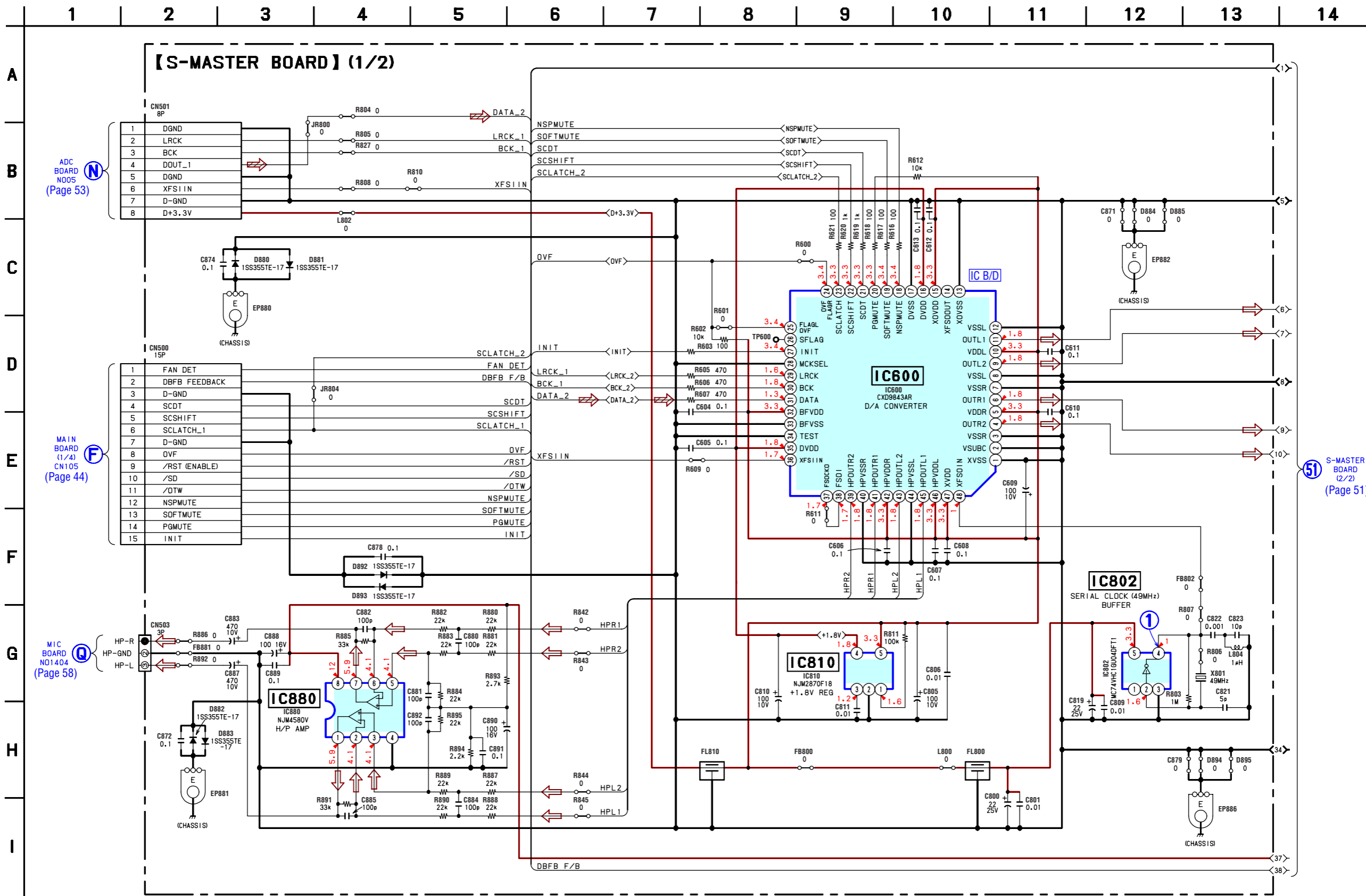

• Refer to page 33 for Waveforms.

6-24. SCHEMATIC DIAGRAM — ADC SECTION — • Refer to page 64 for IC Block Diagrams.

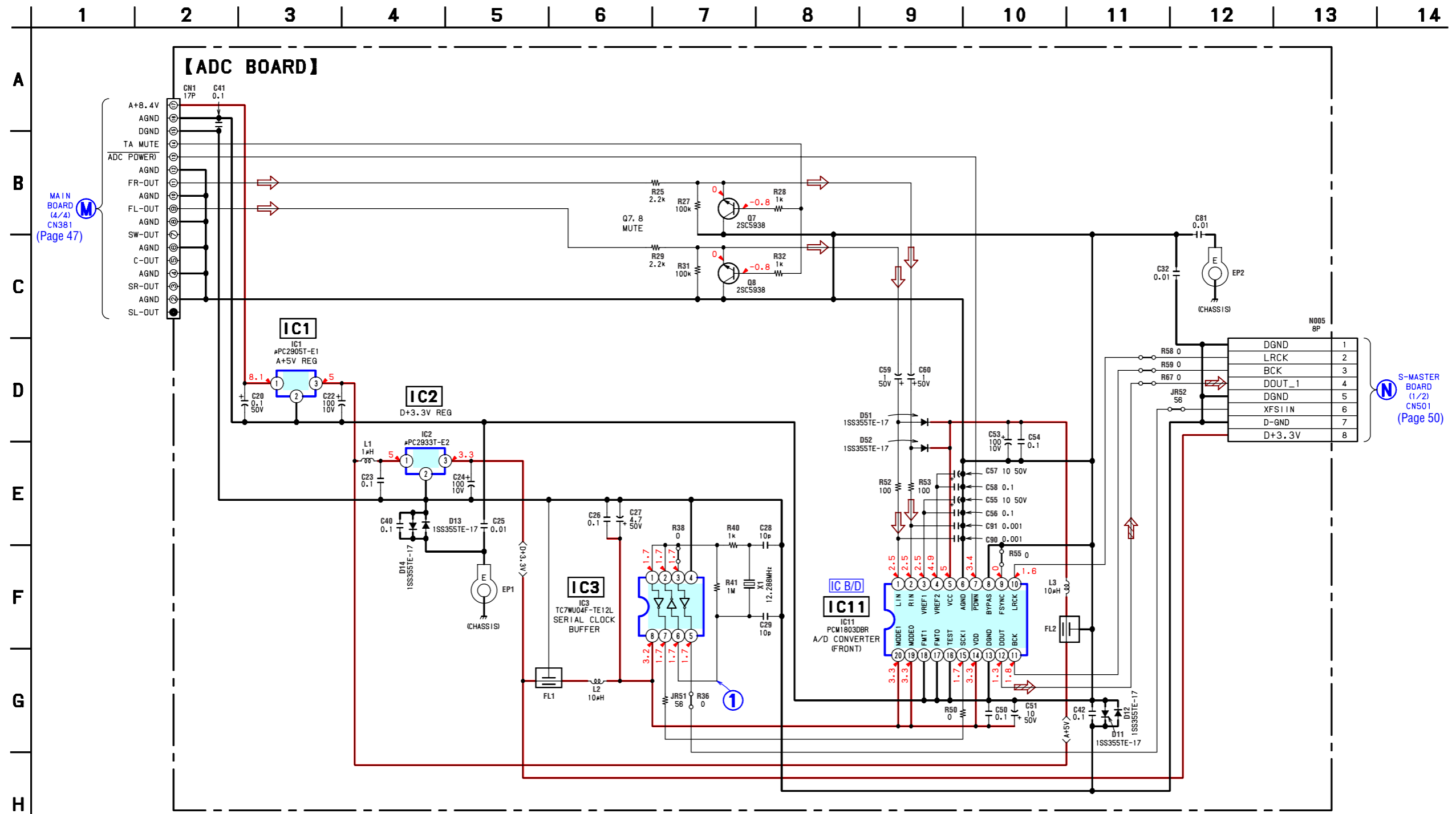

6-25. PRINTED WIRING BOARDS — PANEL SECTION — • Refer to page 32 for Circuit Boards Location.  : Uses unleaded solder.

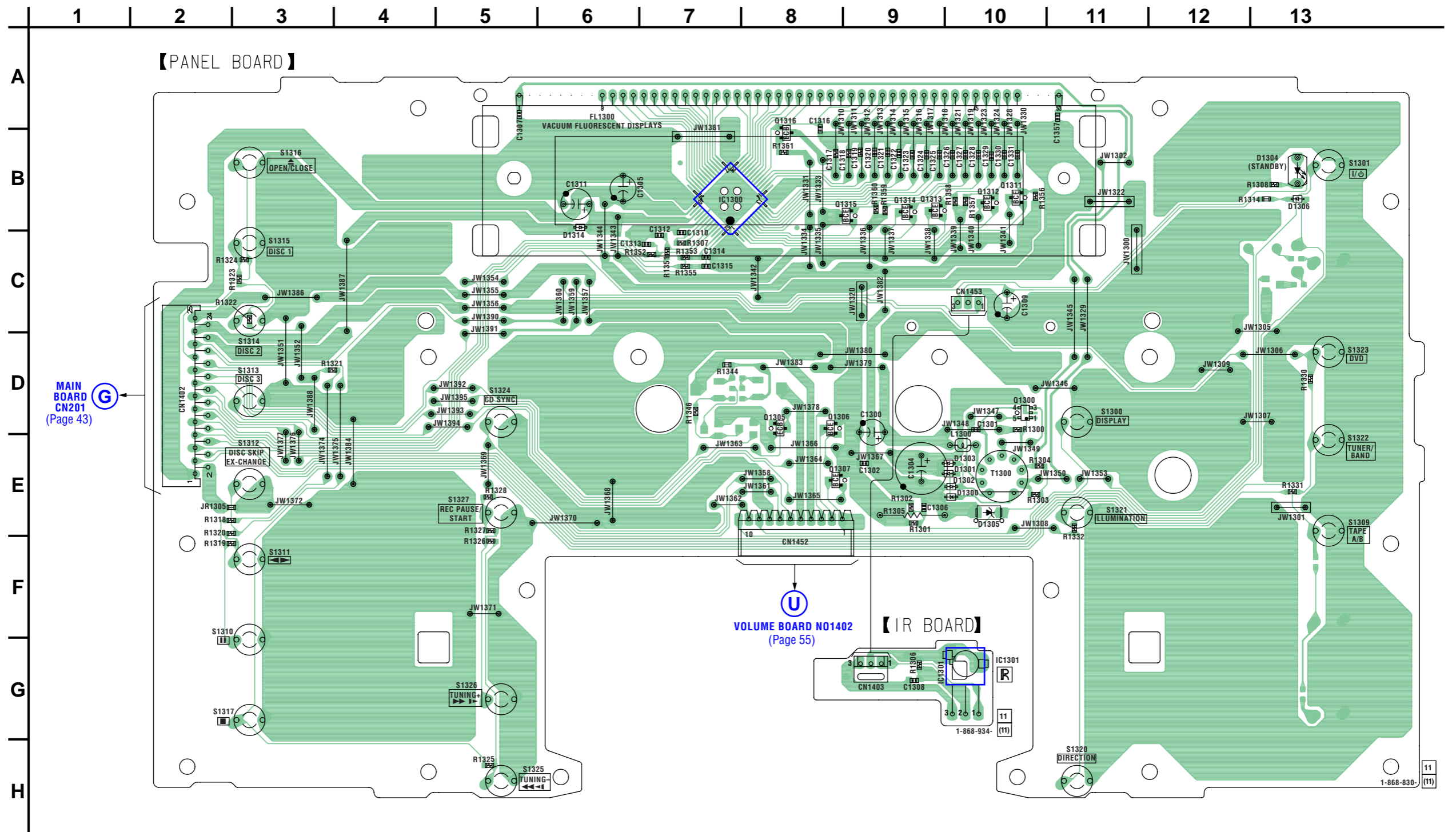

• Semiconductor Location

Ref. No.	Location	Ref. No.	Location
D1300	E-10	Q1300	D-10
D1301	E-10	Q1305	D-8
D1302	E-10	Q1307	E-8
D1303	E-10	Q1311	B-10
D1304	B-13	Q1312	B-10
D1305	E-10	Q1313	B-9
D1306	B-13	Q1314	B-9
D1314	B-6	Q1315	B-9
		Q1316	A-8
IC1300	B-7		
IC1301	G-10		

6-26. PRINTED WIRING BOARD — VOLUME SECTION — • Refer to page 32 for Circuit Boards Location.  : Uses unleaded solder.

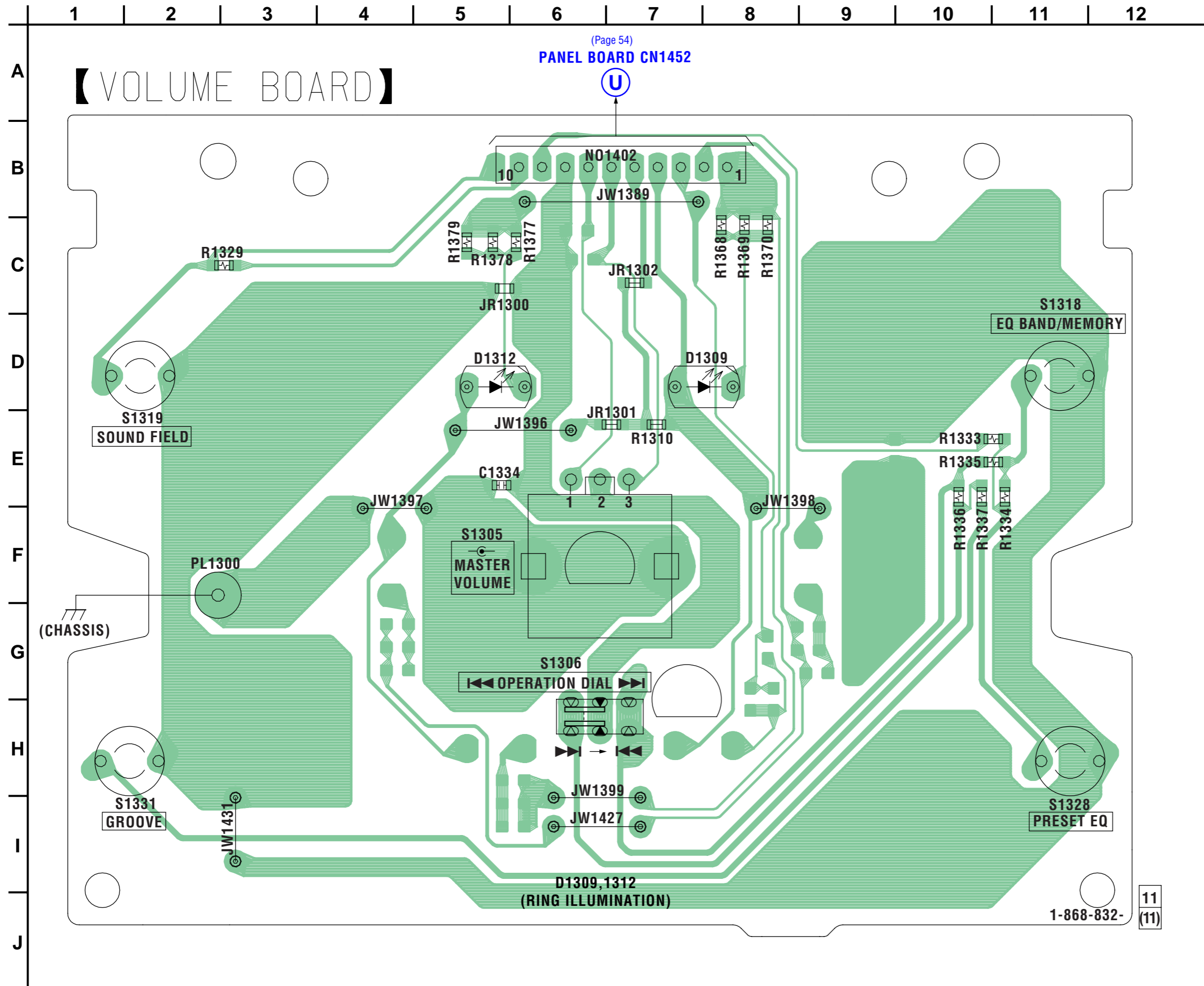

6-27. SCHEMATIC DIAGRAM — PANEL SECTION —

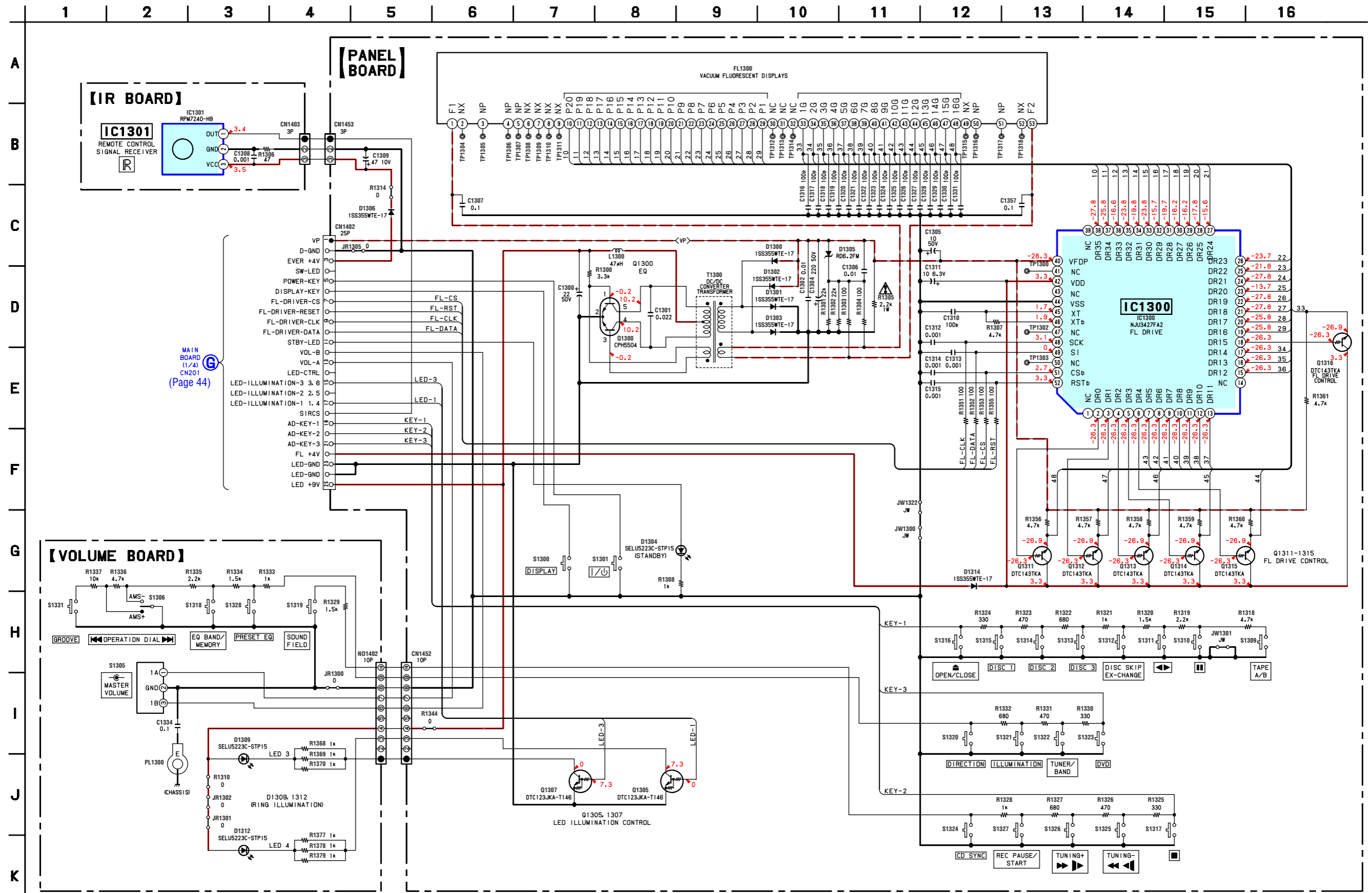

6-28. PRINTED WIRING BOARD — MIC SECTION — • Refer to page 32 for Circuit Boards Location.  : Uses unleaded solder.

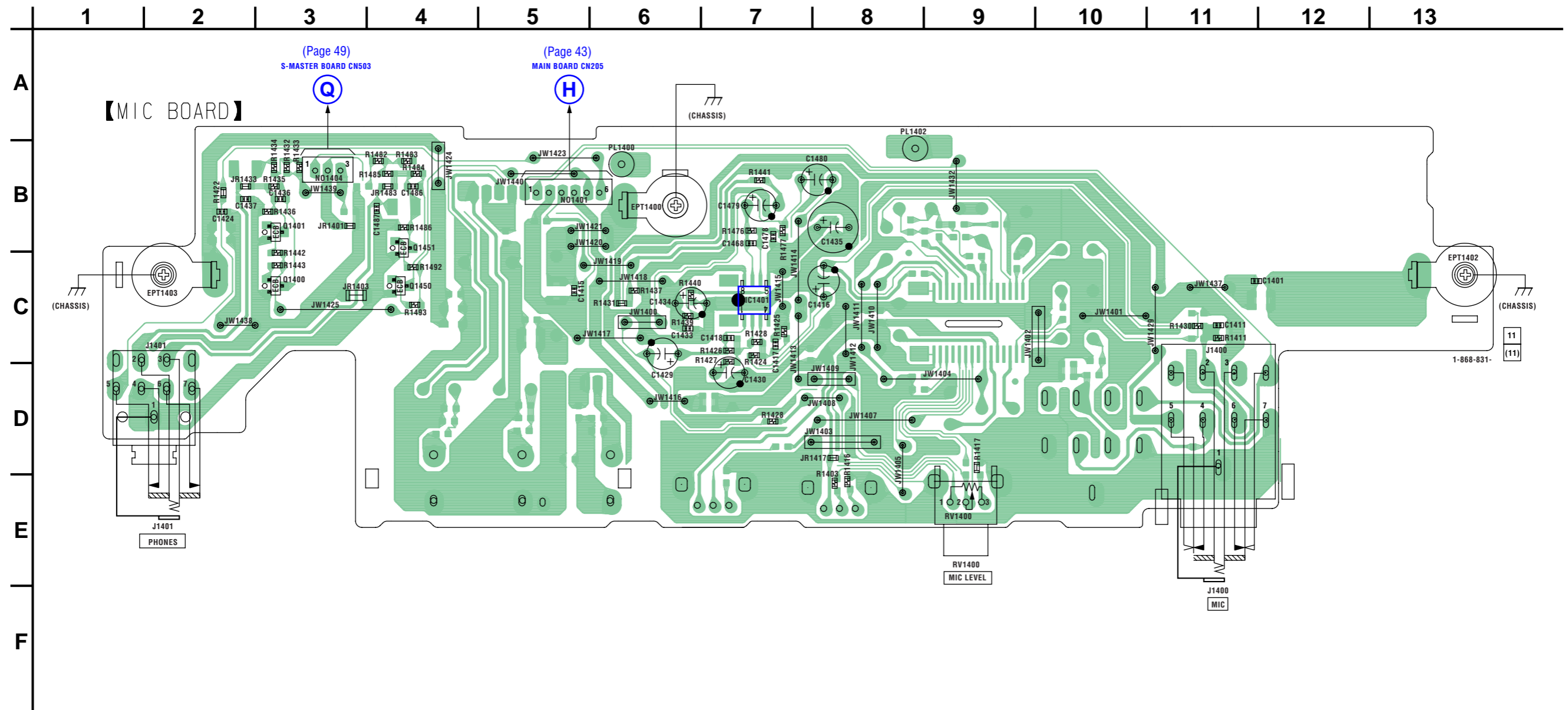

• Semiconductor Location

Ref. No.	Location
IC1401	C-7
Q1400	C-3
Q1401	B-3
Q1450	C-4
Q1451	B-4

6-29. SCHEMATIC DIAGRAM — MIC SECTION —

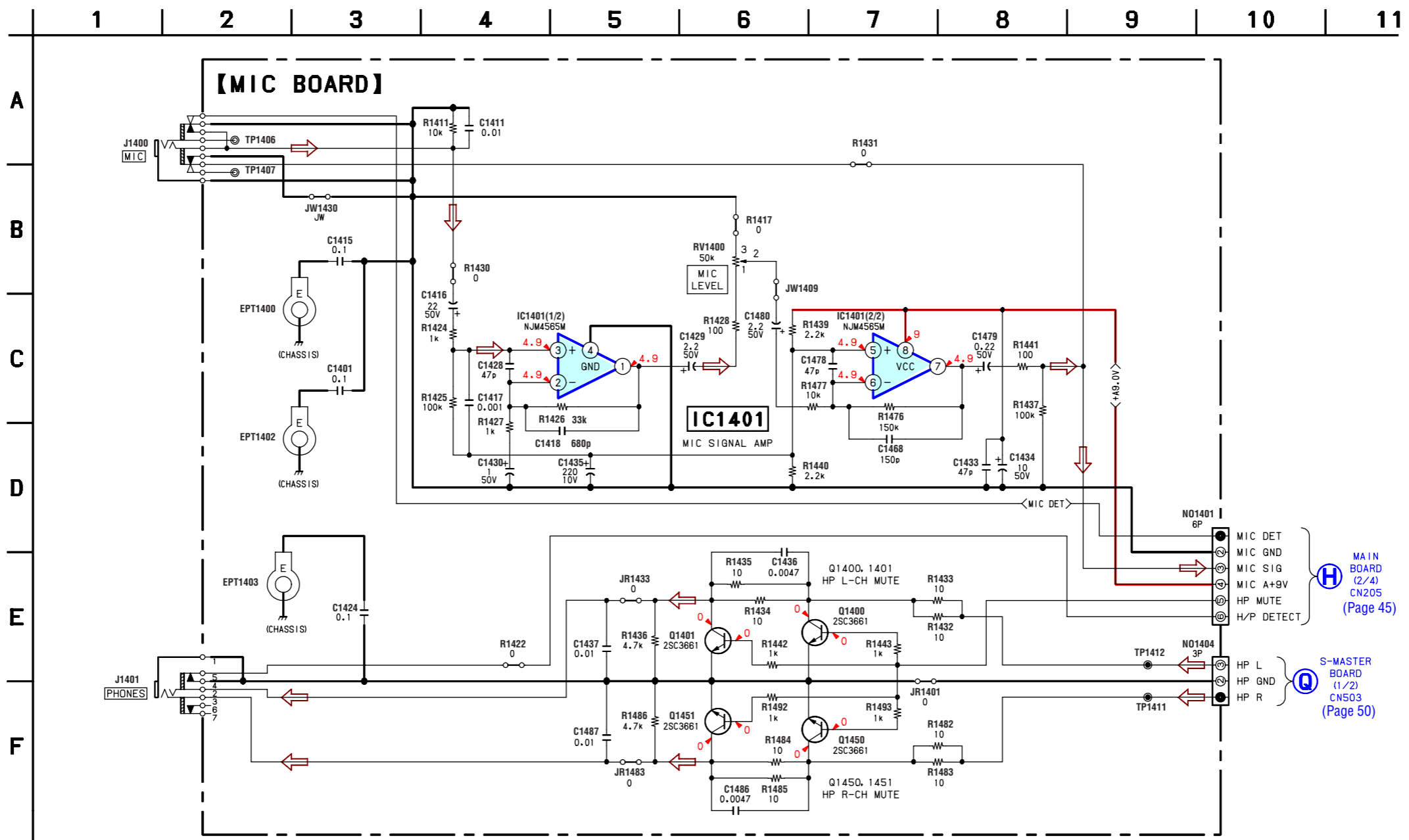

6-31. SCHEMATIC DIAGRAM — VIDEO SECTION —

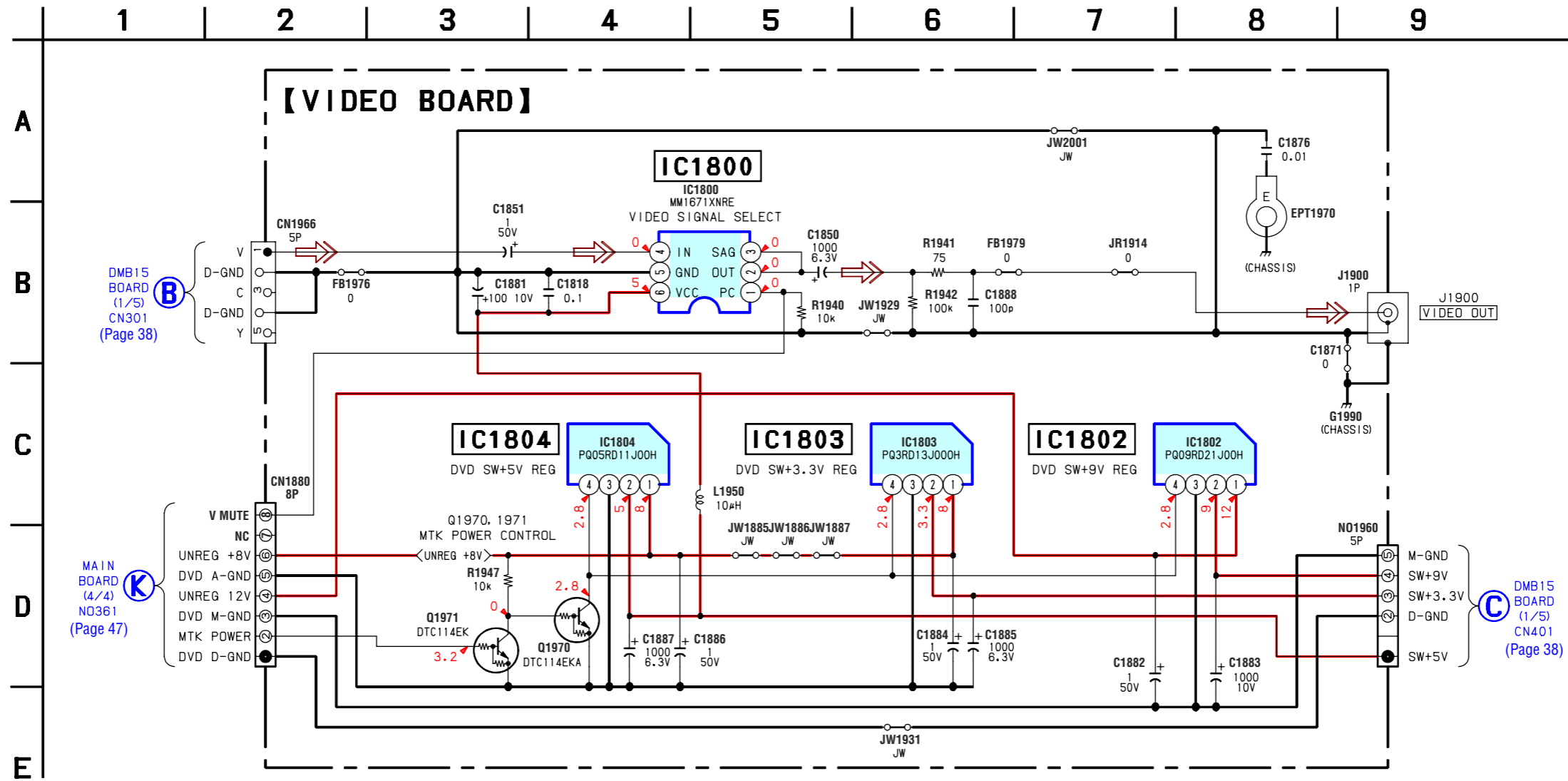

6-32. PRINTED WIRING BOARD — SPEAKER SECTION — • Refer to page 32 for Circuit Boards Location.  : Uses unleaded solder.

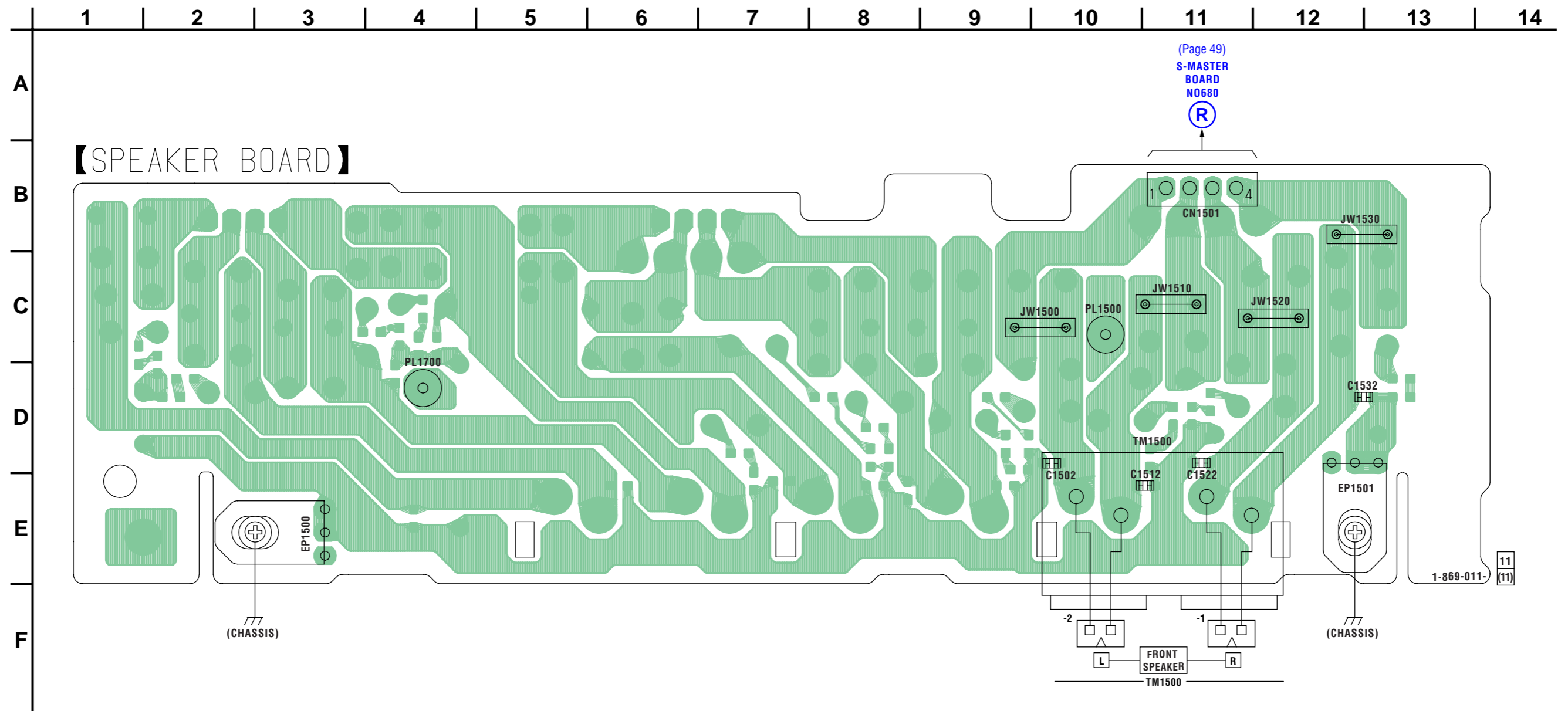

6-33. SCHEMATIC DIAGRAM — SPEAKER SECTION —

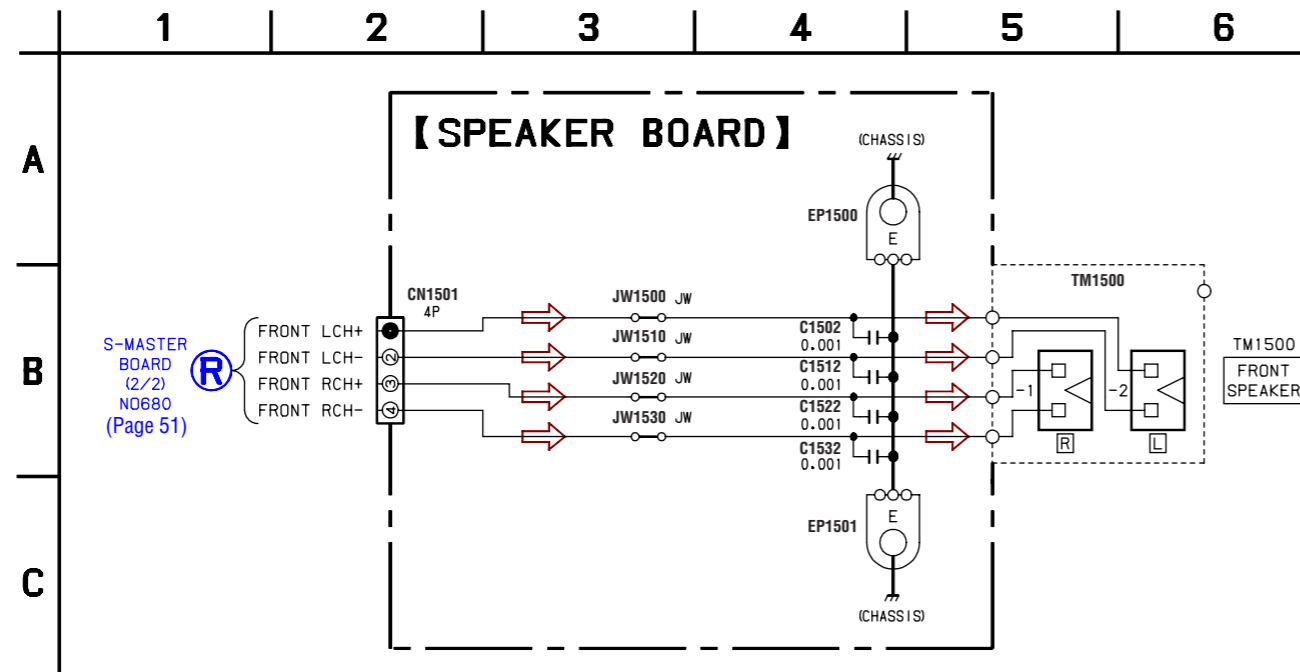

• IC Block Diagrams

IC701 BA6956AN (DRIVER Board)
 IC712 BA6956AN (DRIVER Board)

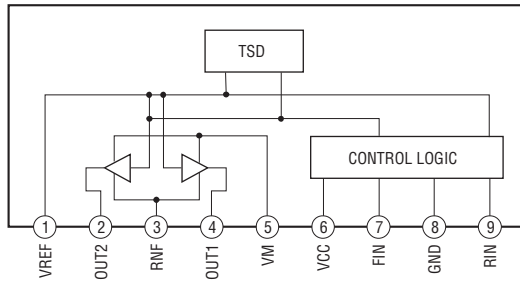

IC301 AK4358VQ-L (DMB15 Board (2/5))

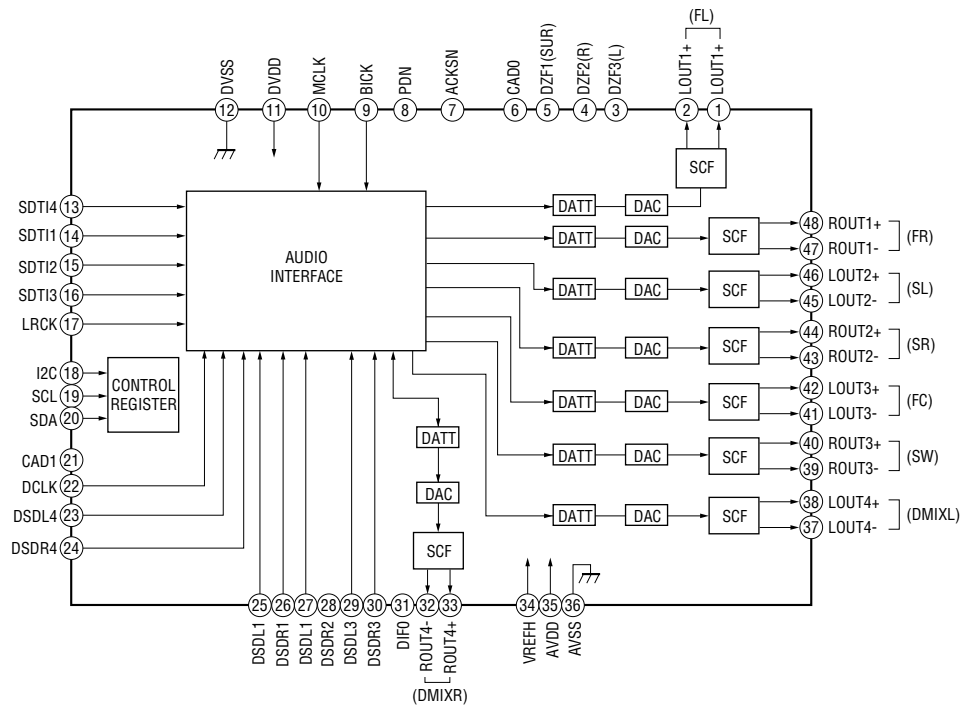

IC600 CXD9843AR (S-MASTER Board (1/2))

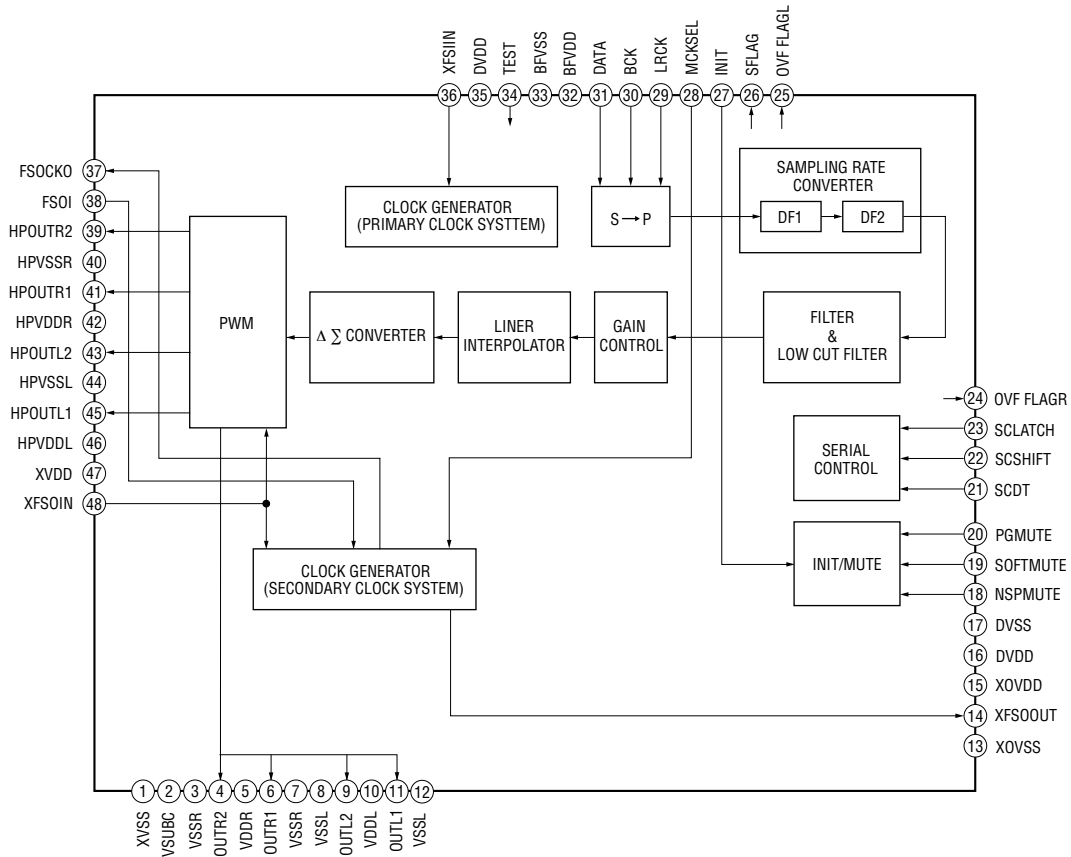

IC11 PCM1803DBR (ADC Board)

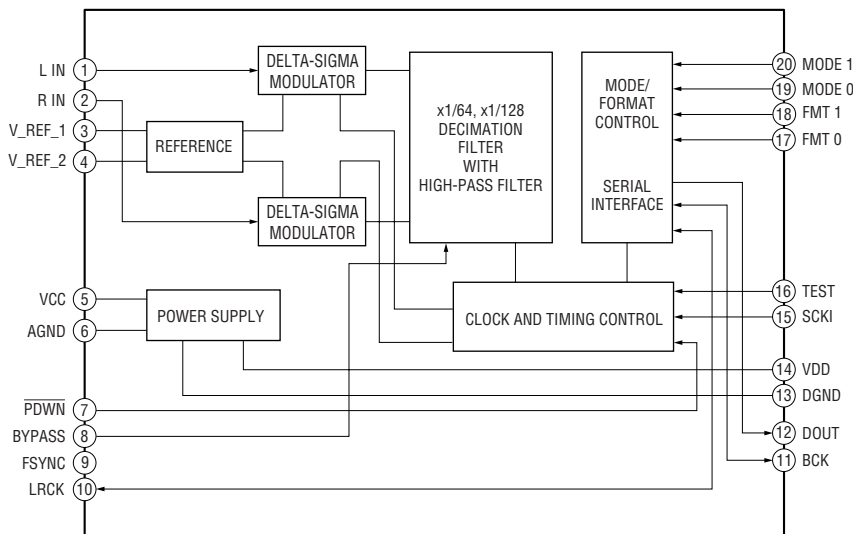

IC630 CXD9845M (S-MASTER Board (2/2))

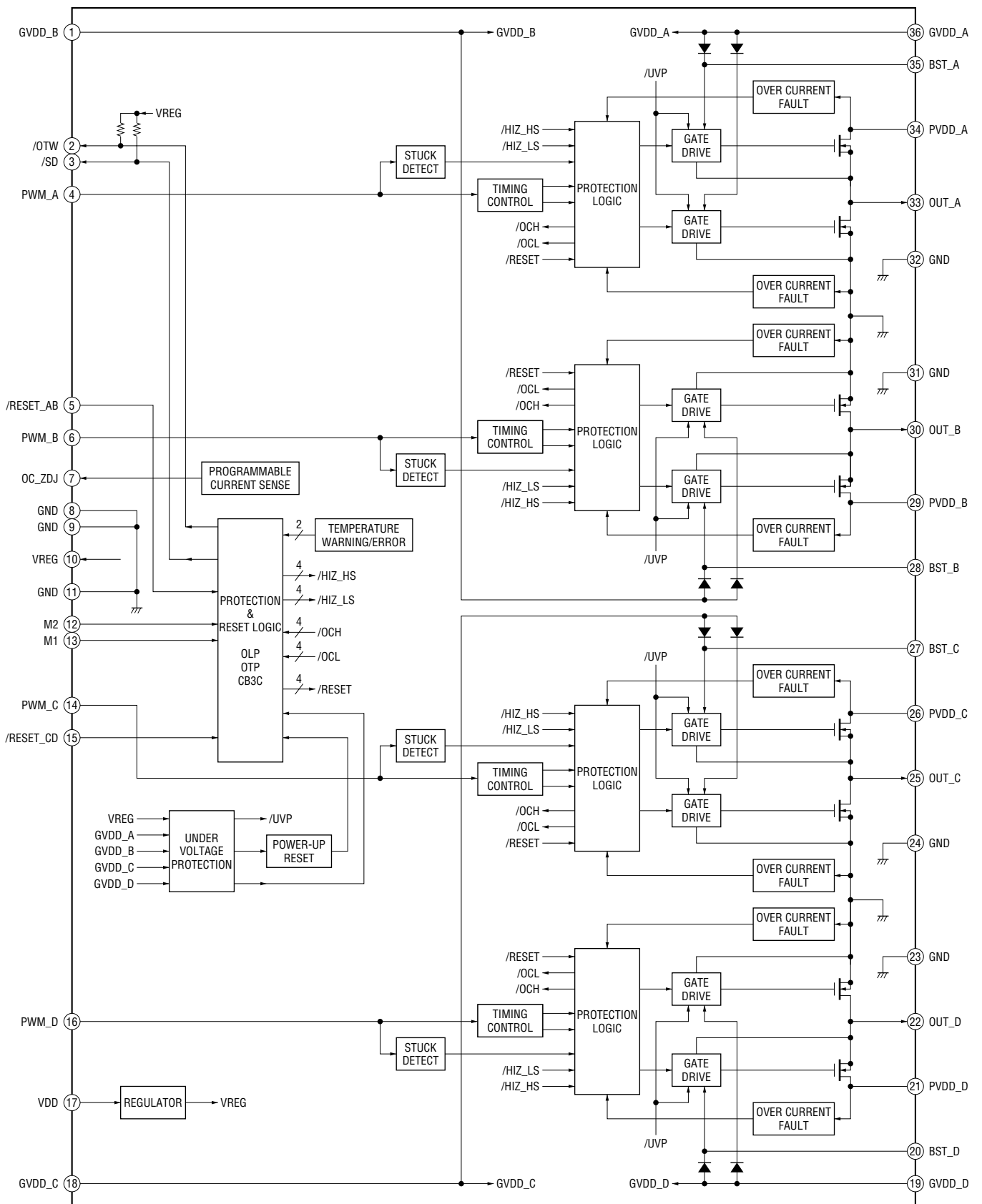

• IC Pin Descriptions

IC102 CXD9849R (CD/DVD RF AMP, FOCUS/TRACKING ERROR AMP, DVD SYSTEM PROCESSOR, DIGITAL SERVO PROCESSOR) (DMB15 BOARD (3/5))

Pin No.	Pin Name	I/O	Pin Description
1	AGND	—	Ground pin
2	DVDA	I	AC coupled input path A
3	DVDB	I	AC coupled input path B
4	DVDC	I	AC coupled input path C
5	DVDD	I	AC coupled input path D
6	DVDRFIP	I	AC coupled DVD RF signal input RFIP
7	DVDRFIN	I	AC coupled DVD RF signal input RFIN Not used in this set. (Open)
8	NA	I	DC coupled main-beam RF signal input A
9	NB	I	DC coupled main-beam RF signal input B
10	MC	I	DC coupled main-beam RF signal input C
11	MD	I	DC coupled main-beam RF signal input D
12	SA	I	DC coupled sub-beam RF signal input A Not used in this set. (Open)
13	SB	I	DC coupled sub-beam RF signal input B Not used in this set. (Open)
14	SC	I	DC coupled sub-beam RF signal input C Not used in this set. (Open)
15	SD	I	DC coupled sub-beam RF signal input D Not used in this set. (Open)
16	CDFON	I	CD focusing error negative input Not used in this set. (Open)
17	CDFOP	I	CD focusing error positive input Not used in this set. (Open)
18	TNI	I	3 beam satellite PD signal negative input
19	TPI	I	3 beam satellite PD signal positive input
20	MDI1	I	Laser power PD monitor signal input
21	MDI2	I	Laser power PD monitor signal input
22	LDO2	O	Laser drive signal output
23	LDO1	O	Laser drive signal output
24	SVDD3	—	Power Supply pin (+3.3 V)
25	CSD	O	Central servo, Positive main beam summing signal output Not used in this set. (Open)
26	RFLVL	O	RFRP low pass, or Positive main beam summing signal output Not used in this set. (Open)
27	SGND	—	Ground pin
28	V2REFO	O	Reference voltage 2.8 V
29	V2O	O	Reference voltage 2.0 V
30	VREFO	O	Reference voltage 1.4 V
31	FEO	O	Focus error monitor signal output Not used in this set. (Open)
32	TEO	O	Tracking error monitor signal output Not used in this set. (Open)
33	TEZISLV	O	TE Slicing Level Not used in this set.
34	OPOUT	O	Op amp output Not used in this set. (Open)
35	OPIN	I	Op amp negative input Not used in this set. (Open)
36	OPIN	I	Op amp positive input Not used in this set. (Open)
37	DMO	O	Disk motor control signal output. PWM signal output
38	FMO	O	Feed motor signal control. PWM signal output
39	TROPENPWM	O	Tray PWM output/Tray open signal output.
40	IOPMON	I	General PWM signal input
41	TRO	O	Tracking servo signal output
42	FOO	O	Focus servo signal output
43	DVSS	—	Ground pin
44	NC	—	Not used. (Open)
45	NC	—	Not used. (Open)
46	DVDD3	—	Power Supply pin (+3.3 V)
47	SPFG	I	Motor Hall sensor signal input
48	DSEL	O	Select signal output

Pin No.	Pin Name	I/O	Pin Description
49	WIDE	I	Wide signal output Not used in this set. (Open)
50	MSW	O	Volume control signal output
51	MAMUTE	O	MAMUTE signal output to System Controller Not used in this set. (Open)
52	DVDD18	—	Power Supply pin (+1.8 V)
53 to 58	IOA 2 to 7	O	Address bus 2 to 7 output to PROM
59	HIGHA0	O	Address bus 8 output to PROM
60, 61	IOA18, 19	O	Address bus 18, 19 output to PROM
62	DVSS	—	Ground pin
63	APLLCAP	I	APLL External Capacitance connection
64	APLLVSS	—	Ground pin
65	VDD3	—	Power Supply pin (+3.3 V)
66	IOWA	O	WE signal output to PROM
67	A16	O	Address bus 16 output to PROM
68 to 72	HIGHA 7 to 3	O	Address bus 15 to 11 output to PROM
73	DVDD3	—	Power Supply pin (+3.3 V)
74, 75	HIGHA 2, 1	O	Address bus 10, 9 output to PROM
76	IOA20	O	Address bus 20 output to PROM
77	IOCS	O	CE signal output to PROM
78	IOA1	O	Address bus 1 output to PROM
79	IOOE	O	OE signal output to PROM
80	DVDD3	—	Power Supply pin (+3.3 V)
81 to 84	AD 0 to 3	I	Data bus 0 to 3 input from PROM
85	DVSS	—	Ground pin
86 to 88	AD 4 to 6	I	Data bus 4 to 6 input from PROM
89	IOA21	O	Address bus 21 output to PROM
90	ALE	O	Address latch enable Not used in this set. (Open)
91	AD7	I	Data bus 7 input from PROM
92	A17	O	Address bus 17 output to PROM
93	IOA0	O	Address bus 0 output to PROM
94	DVSS	—	Ground pin
95	UWA	I	System Controller write strobe Not used in this set. (Open)
96	URD	I	System Controller read strobe Not used in this set. (Open)
97	DVDD18	—	Power Supply pin (+1.8 V)
98	IFSDO	I	DVD SDO signal input from System Controller
99	IFCK	O	DVD SCO signal output to System Controller
100	XIFCS	I	DVD XIFCS signal input from System Controller
101	IFSDI	I	VIFBUSY signal output from System Controller
102	SCL	O	SCL signal output to EEPROM
103	SDA	O	SDA signal output to EEPROM
104	TRG-SW	O	RS232 RXD signal output Not used in this set. (Open)
105	IFBSY	I	RS232 TXD signal input from System Controller
106	RXD	I	RD232 RXD clock
107	TXD	I	RD232 TXD data
108	DVDD3	—	Power Supply pin (+3.3 V)
109	ICE	I	ICE mode enable Not used in this set. (Open)
110	PRST	I	MTRST signal input from System Controller
111	IR	I	IR control signal input Not used in this set. (Open)
112	INT0	I	External interrupt 0 Not used in this set. (Open)
113	DQMO	O	DQMO signal output to SD-RAM
114	MREQ	I	DQM signal input
115	RD7	I	Data bus 7 from SD-RAM
116	DVSS	—	Ground pin
117, 118	RD 6, 5	I	Data bus 6, 5 from SD-RAM

HCD-GNZ55D

Pin No.	Pin Name	I/O	Pin Description
119	DVSS	—	Ground pin
120, 121	RD 4, 3	I	Data bus 4, 3 from SD-RAM
122	DVDD18	—	Power Supply pin (+1.8 V)
123 to 125	RD 2 to 0	I	Data bus 2 to 0 from SD-RAM
126	RD15	I	Data bus 15 from SD-RAM
127	DVDD3	—	Power Supply pin (+3.3 V)
128	RD 14	I	Data bus 14 from SD-RAM
129 to 133	RD 13 to 9	I	Data bus 13 to 9 from SD-RAM
134	DVSS	—	Ground pin
135	RD8	I	Data bus 8 from SD-RAM
136	GPI0	—	Not used in this set. (Open)
137	DQM1	O	DQM1 signal output to SD-RAM
138	RWE	O	WE signal output to SD-RAM
139	CAS	O	CAS signal output to SD-RAM
140	RAS	O	RAS signal output to SD-RAM
141	DVDD3	—	Power Supply pin (+3.3 V)
142	RCS	O	RCS signal output to SD-RAM
143	BA0	O	BA0 signal output to SD-RAM
144	DVSS	—	Ground pin
145	BA1	O	BA1 signal output to SD-RAM
146	RA10	O	Address bus 10 output to SD-RAM
147	RA0	O	Address bus 0 output to SD-RAM
148	DVSS	—	Ground pin
149 to 151	RA 1 to 3	O	Address bus 1 to 3 output to SD-RAM
152	DVDD18	—	Power Supply pin (+1.8 V)
153	NC	—	Not used. (Open)
154	NC	—	Not used. (Open)
155	DVDD3	—	Power Supply pin (+3.3 V)
156	RCLK	O	CLK signal output to SD-RAM
157	CKE	O	CKE signal output to SD-RAM
158 to 160	RA 11 to 8	O	Address bus 11 to 8 output to SD-RAM
161	DVSS	—	Ground pin
162	RA7	O	Address bus 7 output to SD-RAM
163	DVSS	—	Ground pin
164 to 166	RA 6 to 4	O	Address bus 6 to 4 output to SD-RAM
167	DVDD3	—	Power Supply pin (+3.3 V)
168	DISC/X	—	Not used in this set. (Open)
169	RGB	O	RGB control signal output Not used in this set. (Open)
170	TSD M	O	TSDM signal output
171	NC	—	Not used in this set. (Open)
172	NC	—	Not used in this set. (Open)
173	DVDD18	—	Power Supply pin (+1.8 V)
174	FWD	—	Not used in this set. (Open)
175	NC	—	Not used. (Open)
176	LIMSW	O	LIMSW signal output to Optical pick-up
177	OCSW	I	SEN signal input from System Controller/OCSW signal input Not used. (Open)
178	REW	—	Not used in this set. (Open)
179	CKSW	I	CKSW signal input Not used in this set. (Open)
180	NC	—	Not used in this set. (Open)
181	NC	—	Not used in this set. (Open)
182	DVDD3	—	Power Supply pin (+3.3 V)
183	NC	—	Not used in this set. (Open)
184	NC	—	Not used in this set. (Open)

Pin No.	Pin Name	I/O	Pin Description
185	NC	—	Not used in this set. (Open)
186	NC	—	Not used in this set. (Open)
187	NC	—	Not used in this set. (Open)
188	NC	—	Not used in this set. (Open)
189	DAVCC	—	Power Supply pin (+3.3 V)
190	VREF	I	Bandgap reference voltage Not used in this set. (Open)
191	FS	O	Full scale adjustment (pull down)
192	YUV0	—	Not used in this set. (Open)
193	DAVSS	—	Ground pin
194	YUV1	O	Y signal output to VIDEO AMP
195	DAVDD	—	Power Supply pin (+3.3 V)
196	YUV2	O	CHROMA signal output to VIDEO AMP
197	DAVSS	—	Ground pin
198	YUV3	O	VIDEO signal output to VIDEO AMP
199	DAVDD	—	Power Supply pin (+3.3 V)
200	YUV4	O	Not used in this set. (Connect to VCC.)
201	DAVSS	—	Ground pin
202	YUV5	O	Not used in this set. (Connect to VCC.)
203	YUV6	O	Not used in this set. (Connect to VCC.)
204	DVDD3	—	Power Supply pin (+3.3 V)
205	MIC/VSYN	I	Microphone status signal input
206	VOICE/YUV7	I	Not used in this set. (Connect to VCC.)
207	KRMOB/HSYN	O	Karaoke mode detection signal output
208	SMSCK	I	Not used in this set. (Open)
209	SPDATA/SMSDI	I	Audio data of SPDIF input Not used in this set. (Connect to VCC.)
210	MUTE	O	Mute signal output
211	MUTE123	O	Mute signal output
212	DVDD3	—	Power Supply pin (+3.3 V)
213	ALRCK	I	Audio left/right channel clock signal input
214	ABCK	O	Audio bit clock signal output
215	ACLK	I	Audio DAC master clock signal input
216	DVSS	—	Ground pin
217	ASDATA0	O	Audio serial data signal output
218	ASDATA1	O	Audio serial data signal output
219	ASDATA2	O	Audio serial data signal output
220	XRST	O	Reset signal output
221	DVDD18	—	Power Supply pin (+1.8 V)
222	ASDATA4	O	Audio serial data signal output
223	DVSS	—	Ground pin
224	DWIDE	—	Not used in this set. (Open)
225	SDPIF	O	SPDIF signal output
226	RFGND18	—	Ground pin
227	RFVDD18	—	Power Supply pin (+1.8 V)
228	ZTALO	O	Oscillator signal output (27 MHz)
229	ZTALI	I	Oscillator signal input (27 MHz)
230	JITFO	O	RF jitter meter output
231	JITFN	I	Negative input of operation amplifier for RF jitter meter
232	PLLVSS	—	Ground pin
233	IDAC	—	Not Used.
234	PLLVDD3	—	Power Supply pin (+3.3 V)
235	LPFON	O	Negative output of loop filter amplifier
236	LPFIP	I	Positive input of loop filter amplifier
237	LPFIN	I	Negative input of loop filter amplifier

HCD-GNZ55D

Pin No.	Pin Name	I/O	Pin Description
238	LPFOP	O	Positive output of loop filter amplifier
239	VDD3	I	Power Supply pin (+3.3 V)
240	NC	—	Not used. (Open)
241	VSS	—	Ground pin
242	NC	—	Not used. (Open)
243	NC	—	Not used. (Open)
244	RFVDD3	—	Power Supply pin (+3.3 V)
245	RFRPDC	I	RFRP signal input
246	RFRPAC	I	RFRP signal input
247	HRFZC	I	High frequency RF ripple zero crossing
248	CRTPLP	O	Defect level filter capacitor connecting
249	RFGND	—	Ground pin
250	NC	—	Not used. (Open)
251	NC	—	Not used. (Open)
252	OSP	O	RF offset cancellation capacitor connecting
253	OSN	I	RF offset cancellation capacitor connecting
254	RFGC	O	RF offset loop capacitor connecting for DVD-ROM
255	IREF	I	Current reference input
256	AVDD3	—	Power Supply pin (+3.3 V)

IC401 M30622MEP-A50FPU0 (SYSTEM CONTROL) (MAIN BOARD (1/4))

Pin No.	Pin Name	I/O	Pin Description
1	SW CHANNEL SELECT	O	Signal path selection signal for sub woofer channel “L”: LFE, “H”: Subwoofer out from M61537 Not used in this set. (Open)
2	SURR CHANNEL SELECT	O	Signal path selection signal for surround channel “L”: SL/FR (MTK), “H”: Tone out from M61537 Not used in this set. (Open)
3	SM LATCH 3	O	Serial data latch pulse output to the S-Master Processor
4	SIRCS	I	Remote control signal input
5	NO USE	I	Not used. (Connect to ground.)
6	NO USE	I	Not used. (Connect to ground.)
7	NO USE	I	Not used. (Connect to ground.)
8	BYTE	—	Ground pin
9	CNVSS	—	Ground pin
10	XC IN	I	Sub system clock input (32.768 kHz)
11	XC OUT	O	Sub system clock output (32.768 kHz)
12	RESET	I	System reset signal input from the reset signal IC “L”: reset After the power supply rises, “L” is input for several hundreds msec and then change to “H”.
13	X OUT	O	Main system clock output (5 MHz)
14	VSS	—	Ground pin
15	X IN	I	Main system clock input (5 MHz)
16	VCC	—	Power supply pin (+3.3 V)
17	NMI	I	Non-maskable interrupt input
18	NO USE	I	Not used. (Connect to ground.)
19	NO USE	I	Not used. (Connect to ground.)
20	AC CUT	I	AC off detection signal input from the reset signal IC “L”: AC Cut detected
21	VIDEO MUTE	O	Video muting on/off control signal output “L”: muting on
22	VIDEO OUT SW	O	Composite video output switching output control “L”: DVD VIDEO output, “H”: VIDEO VIDEO input
23	MIC DETECT	I	Microphone connection detection signal input “L”: headphone connected
24	KRMOD	I	Karaoke Mode detection signal input
25	MIC STATUS	O	Microphone status output to DVD Motherboard “L”: Microphone is not connected, “H”: Microphone is connected
26	MTK RESET	O	Reset signal output to DVD Motherboard “L”: reset
27	MTK XIFCS	I	Communication Initialization Request Acknowledgement Signal from DVD Motherboard
28	MTK BUSY	O	Communication Initialization Request Signal to DVD Motherboard
29	IIC CLK	I/O	Clock signal for IIC communication between the microcomputer and the IIC checker
30	IIC DATA	I/O	Data signal for IIC communication between the microcomputer and the IIC checker
31	MTK SIO	O	Serial data output signal to DVD Motherboard
32	MTK SOD	I	Serial data input signal from DVD Motherboard
33	MTK CLK	I	Serial data clock signal to DVD Motherboard
34	DVD A MUTE	O	DVD analog signal muting on/off control signal output “H”: muting on
35	MTK POWER	O	Power supply control signal to DVD Motherboard “H”: Power supply on
36	ST CE	O	PLL chip enable signal output to the tuner unit
37	MC DIN	I	PLL serial data input from the tuner unit
38	ST CLK	O	PLL serial data transfer clock signal output to the tuner unit
39	MC DOUT	O	PLL serial data output to the tuner unit
40	TUNED	I	Tuning detection signal input from the tuner unit “L”: tuned
41	OPEN SW	I	Eject detection signal input from CDM
42	TBL SENSE	I	Disc tray position detection signal input from CDM
43	E3	I	Disc tray status detection signal input from CDM
44	E2	I	Disc tray status detection signal input from CDM
45	E1	I	Disc tray status detection signal input from CDM
46	TM F	O	CDM turning motor control signal output

HCD-GNZ55D

Pin No.	Pin Name	I/O	Pin Description
47	TM R	O	CDM turning motor control signal output
48	LM F	O	CDM loading motor control signal output
49	LM R	O	CDM loading motor control signal output
50	LED ILLUMINATION 1	O	Dynamic LED drive signal output to the ILLUMINATION 1st indicator and 2nd indicator "H": LED on
51	LED ILLUMINATION 2	O	Dynamic LED drive signal output to the ILLUMINATION 3rd indicator and 4th indicator "H": LED on
52	LED ILLUMINATION 3	O	Dynamic LED drive signal output to the ILLUMINATION 5th indicator and 6th indicator "H": LED on
53	LED CTRL	O	Dynamic LED drive select signal output
54	VOL A	I	Jog dial pulse input from the VOLUME rotary encoder (A phase input)
55	VOL B	I	Jog dial pulse input from the VOLUME rotary encoder (B phase input)
56	STBY LED	O	LED drive signal output of POWER indicator "H": LED is turned on
57	FL DRIVER DATA	O	Serial data output signal to FL Driver, NJU3427
58	FL DRIVER CLK	O	Serial data clock signal to FL Driver, NJU3427
59	FL DRIVER RESET	O	Serial data reset signal to FL Driver, NJU3427
60	FL DRIVER CS	O	Serial data chip select signal to FL Driver, NJU3427
61	SW LED	O	LED drive signal output of SUB WOOFER ON indicator "H": LED ON
62	VCC	—	Power supply pin (+3.3 V)
63	A HALF	I	Deck A cassette detection signal input "H": cassette detected
64	VSS	—	Ground pin
65	SM RESET	O	Reset signal output to the S-Master Power IC
66	IO EXP DATA OUT	O	Serial data output signal to I/O expander, BH2210V
67	NO USE	I	Not used. (Connect to ground.)
68	IO EXP RST	O	Reset signal output to the I/O expander, BH2210V
69	IO EXP CLK	O	Serial data clock signal to I/O expander, BH2210V
70	IO EXP LAT	O	Serial data latch signal to I/O expander, BH2210V
71	NO USE	I	Not used. (Connect to ground.)
72	SM SD	I	Shutdown (protector) detection signal from the S-Master power IC
73	DISPLAY KEY	I	DISPLAY key press detection signal (Interrupt input)
74	POWER KEY	I	POWER key press detection signal (Interrupt input)
75	NO USE	I	Not used. (Connect to ground.)
76	SM LATCH 1	O	Serial data latch pulse output to the S-Master Processor
77	SM CLK	O	Serial data transfer clock signal to the S-Master Processor IC (CXD9843)
78	SM DATA	O	Serial data output signal to the S-Master Processor IC (CXD9843)
79	SM LATCH 2	O	Serial data latch pulse output to the S-Master Processor
80	NO USE	I	Not used. (Connect to ground.)
81	NO USE	O	Not used. (Connect to ground.)
82	OUT2DLY SEL	I	PWM Mode selection signal "L": PWM Mode 3, "H": PWM Mode 4
83	M61537 DATA	O	Serial data output to audio signal processor, M61537FP
84	M61537 CLK	O	Serial data transfer clock signal output to audio signal processor, M61537FP
85	HP DET	I	Headphone connection detection signal input "H": headphone connected
86	HP MUTE	O	Headphone muting on/off control signal "H": muting on
87	NO USE	I	Not used. (Connect to ground.)
88	VACS IN	I	VACS level detection signal
89	A SHUT	I	Shut off detection signal input from deck A side reel pulse detector (A/D input)
90	B SHUT	I	Shut off detection signal input from deck B side reel pulse detector (A/D input)
91	B HALF	I	Deck B cassette detection and forward side recording tab detection signal input (A/D input)
92	MODEL IN	I	Model setting (A/D input)
93	DEST IN	I	Destination setting (A/D input)
94	AD KEY 3	I	Key signal input (A/D input)
95	AD KEY 2	I	Key signal input (A/D input)

Pin No.	Pin Name	I/O	Pin Description
96	AVSS	—	Ground pin
97	AD KEY 1	I	Key signal input (A/D input)
98	VREF	I	A/D Converter reference voltage input (+3.3 V)
99	AVCC	—	Power supply pin (+3.3 V) (for A/D conversion)
100	MAIN ON/OFF	O	Main power on/off control signal output “H”: power on

IC403 BH2210FV-E2 (SIGNAL IN/OUT CONTROL) (MAIN BOARD (2/4))

Pin No.	Pin Name	I/O	Pin Description
1	CTLIO	I	IN/OUT control port (Fixed at "H" in this set.)
2	RESET	I	Reset signal input
3	CLK	I	Serial data clock signal input
4	LATCH	I	Serial data latch signal input
5	TC-MUTE	O	Tape playback muting on/off control signal output "H": muting on
6	NO USE	O	Not used. (Open)
7	REC MUTE	O	Recording muting on/off control signal output "L": muting on
8	NO USE	O	Not used. (Open)
9	SM-NSP-MUTING	O	S master processor IC PWM 50% duty muting on/off control signal output "L": muting on
10	SM-SOFT-MUTING	O	S master processor IC soft muting on/off control signal output "L": muting on
11	SM-PG-MUTE	O	S master processor IC PWM muting on/off control signal output "L": muting on
12	SM-INIT	O	Initialization signal to the S master processor IC
13	LATCHO	O	Serial data latch output signal Not used. (Open)
14	CLKO	O	Serial data clock signal output Not used. (Open)
15	DO1	O	Serial data signal output 1 Not used. (Open)
16	DI2	I	Serial data signal input 2 Not used. (Connect to ground.)
17	A-TRIG	O	Deck A side trigger plunger drive signal output "H": plunger on
18	CAMP-CNT	O	Capstan motor drive signal output
19	B-TRIG	O	Deck B side trigger plunger drive signal output "H": plunger on
20	REC BIAS	O	Recording bias on/off control signal output "H": bias on
21	TC RELAY	O	Recording/playback selection signal output "H": recording, "L": playback
22	ADC RESET	O	Power down control signal to analog to digital converter "L": power down
23	NO USE	O	Not used. (Open)
24	FAN CTRL	O	Fan driving signal output "L": fan on Not used in this set. (Open)
25	DO2	O	Not used. (Open)
26	DI1	I	Serial data signal input
27	VSS	—	Ground pin
28	VDD	—	Power supply pin (+3 V)

SECTION 7 EXPLODED VIEWS

NOTE:

- The mechanical parts with no reference number in the exploded views are not supplied.
- Items marked “*” are not stocked since they are seldom required for routine service. Some delay should be anticipated when ordering these items.
- -XX and -X mean standardized parts, so they may have some difference from the original one.
- Accessories are given in the last of this parts list.

- Abbreviation
 E3 : 240 V AC area in E model
 E12 : 220-240 V AC area in E model
 E13 : 220-230 V AC area in E model
 E15 : Iran model
 EA : Saudi Arabia model
 MY : Malaysia model
 PH : Philippine model
 SP : Singapore model
 TH : Thai model

The components identified by mark Δ or dotted line with mark Δ are critical for safety. Replace only with part number specified.

7-1. MAIN SECTION

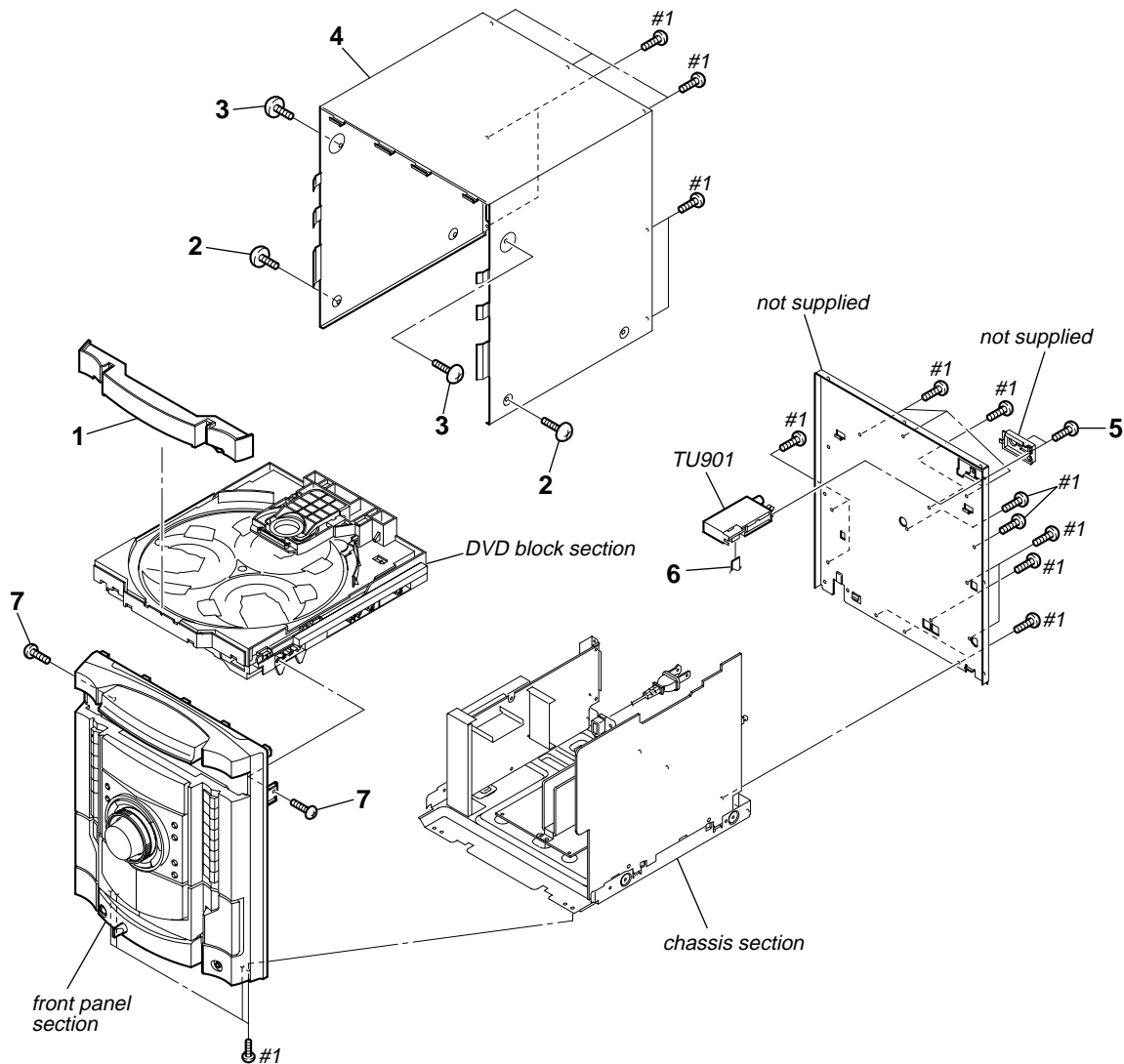

Ref. No.	Part No.	Description	Remark	Ref. No.	Part No.	Description	Remark
1	2-658-345-21	PANEL, LOADING		6	1-828-955-11	WIRE (FLAT TYPE) (9 CORE)	
2	3-363-099-02	SCREW (CASE 3 TP2)		7	3-703-136-12	SCREW, TAPPING	
3	3-363-099-32	SCREW (CASE 3 TP2)		TU901	1-693-702-11	TUNER (FM/AM) (TM10SE)	
4	4-248-760-71	CASE, CABINET STEEL		#1	7-685-646-79	SCREW +BVTP 3X8 TYPE2 TT (B)	
5	2-630-050-01	+BVTT 3X6 (SUMITITE)					

7-2. FRONT PANEL SECTION (1)

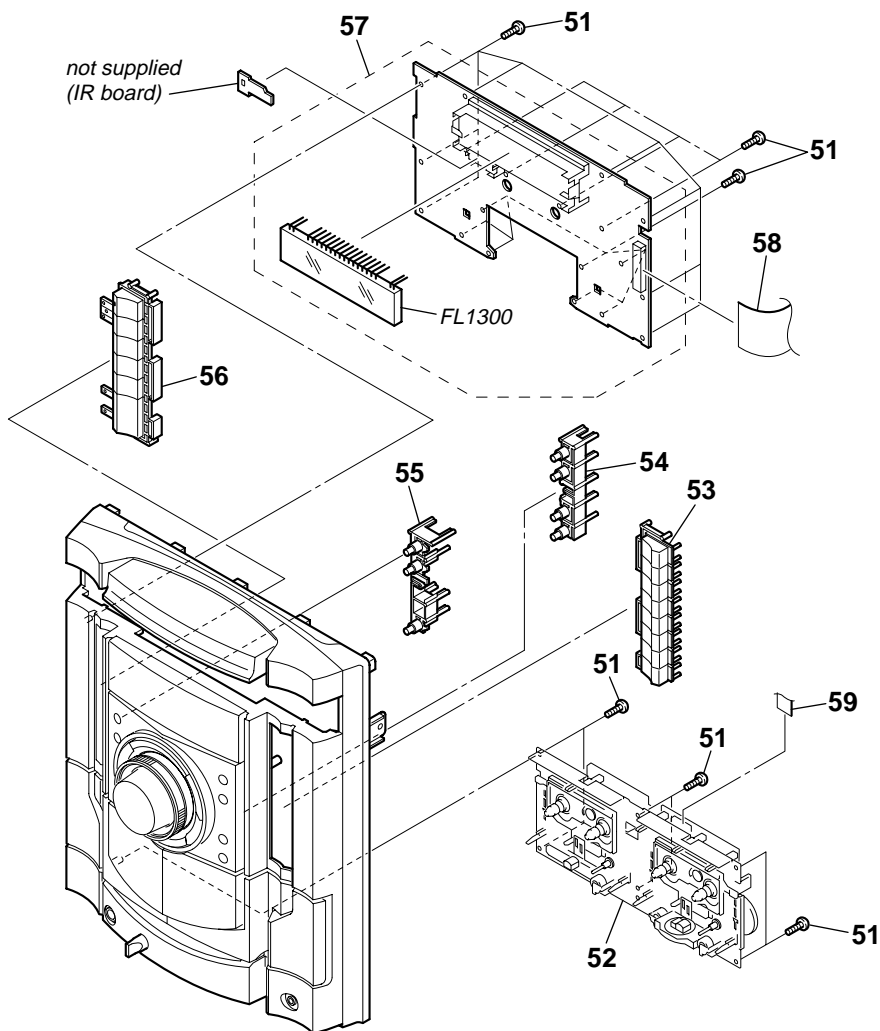

Ref. No.	Part No.	Description	Remark	Ref. No.	Part No.	Description	Remark
51	3-087-053-01	+BVTP 2.6 (3CR)		56	X-2103-444-1	BUTTON (FUNCTION) ASSY	
52	1-417-657-11	MECHA DECK		57	A-1167-723-A	PANEL BOARD, COMPLETE	
53	2-658-347-11	BUTTON (DISC)		58	1-829-030-11	WIRE (FLAT TYPE) (25 CORE)	
54	2-658-348-11	BUTTON (REC)		59	1-827-720-11	WIRE (FLAT TYPE) (11 CORE)	
55	2-658-349-11	BUTTON (DISPLAY)		FL1300	1-519-859-11	VACUUM FLUORESCENT DISPLAY	

7-3. FRONT PANEL SECTION (2)

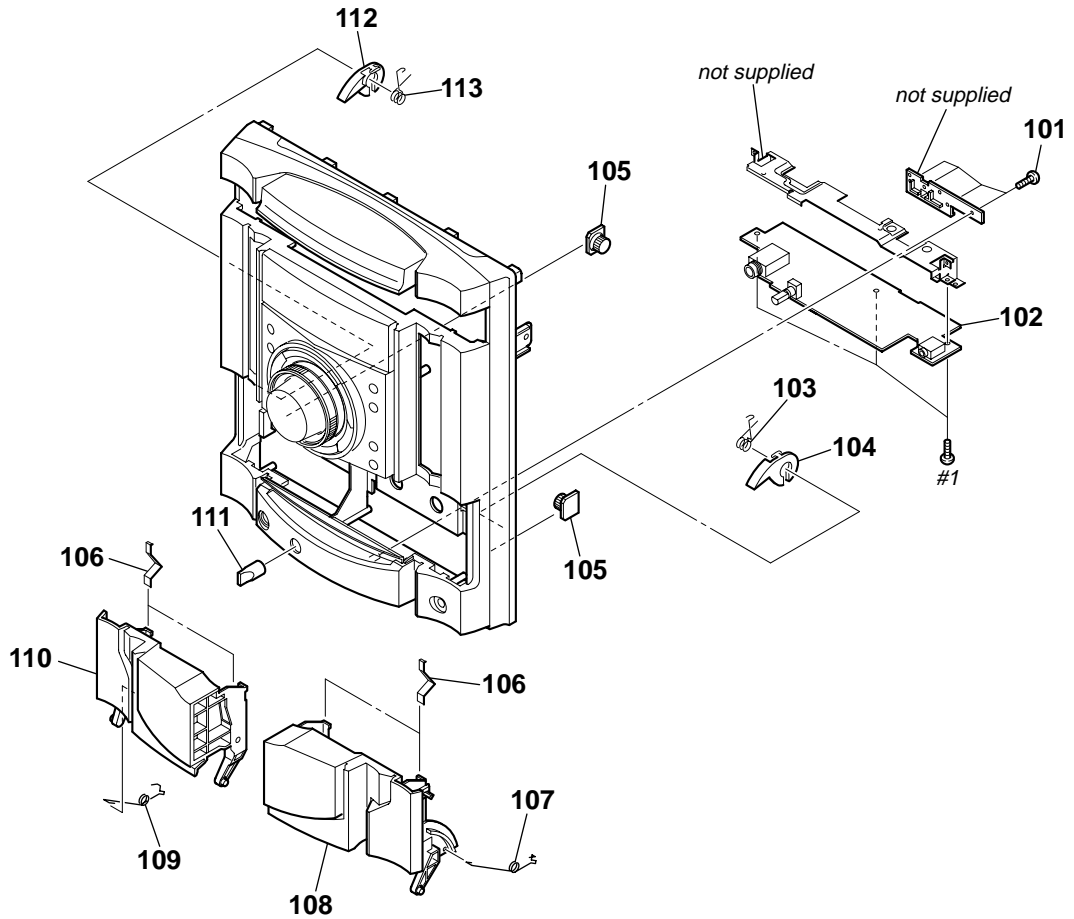

Ref. No.	Part No.	Description	Remark	Ref. No.	Part No.	Description	Remark
101	3-087-053-01	+BVTP 2.6 (3CR)		108	2-658-356-11	HOLDER (TC-R)	
102	A-1167-725-A	MIC BOARD, COMPLETE		109	2-658-367-01	SPRING (L)	
103	4-231-841-01	SPRING (HEART CAM-B)		110	2-658-355-11	HOLDER (TC-L)	
104	4-231-825-01	CAM (B), HEART		111	4-238-628-31	KNOB (MIC)	
105	4-224-104-41	DAMPERS		112	4-231-824-01	CAM (A), HEART	
106	4-238-631-01	SPRING, TAPE		113	4-231-836-01	SPRING (HEART CAM-A)	
107	2-658-368-01	SPRING (R)		#1	7-685-646-79	SCREW +BVTP 3X8 TYPE2 TT (B)	

7-4. FRONT PANEL SECTION (3)

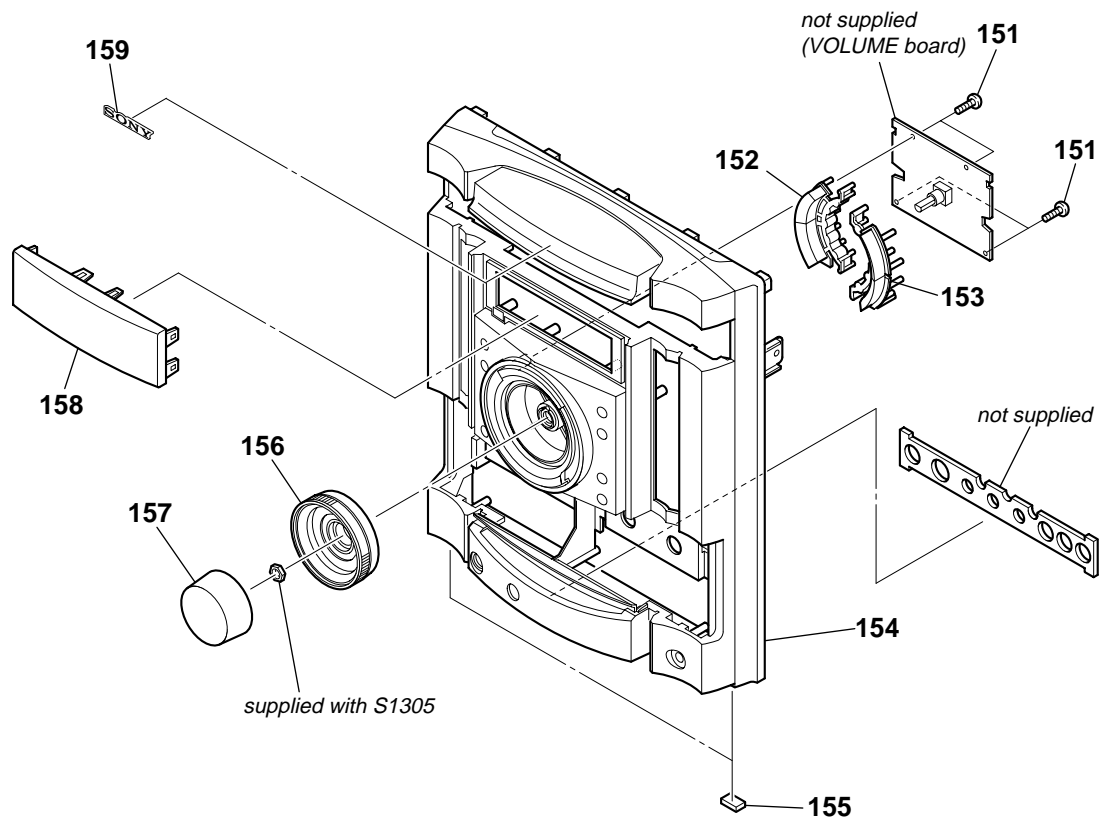

Ref. No.	Part No.	Description	Remark	Ref. No.	Part No.	Description	Remark
151	3-087-053-01	+BVTP 2.6 (3CR)		156	X-2103-595-1	KNOB JOG ASSY	
152	2-658-354-01	BUTTON (EQ)		157	2-590-671-01	KNOB (VOL)	
153	2-659-548-11	BUTTON (EQ2)		158	2-658-350-01	WINDOW (FL)	
154	2-658-343-21	PANEL, FRONT		159	4-217-485-21	EMBLEM (5-A), SONY	
155	4-225-252-01	CUSHION (FOOT)					

7-5. CHASSIS SECTION

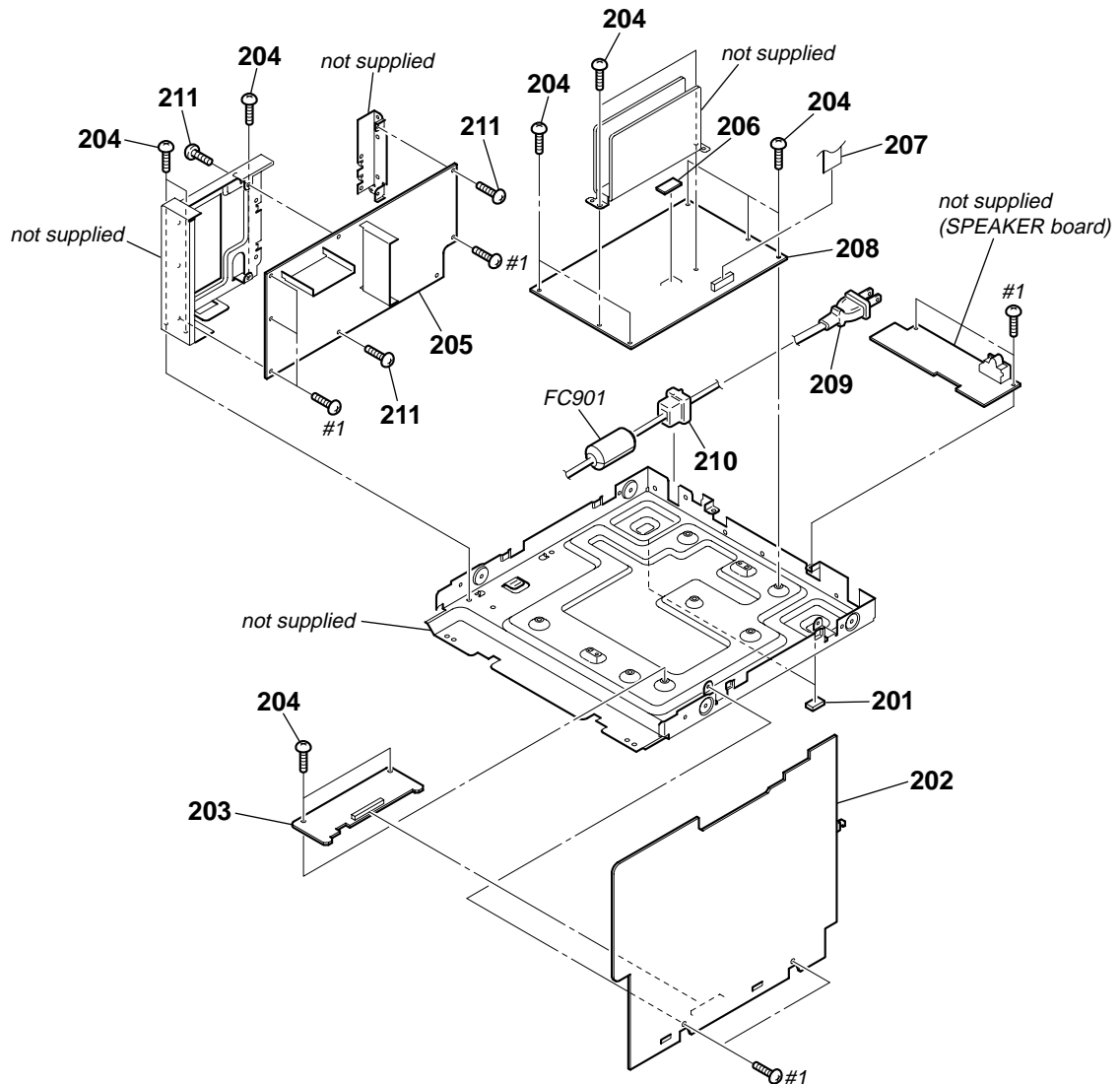

Ref. No.	Part No.	Description	Remark	Ref. No.	Part No.	Description	Remark
201	4-225-252-01	CUSHION (FOOT)		△ 205	1-479-627-11	POWER UNIT	
202	A-1159-563-A	MAIN BOARD, COMPLETE (E3)		206	2-597-972-31	SHEET, RADIATION	
202	A-1189-052-A	MAIN BOARD, COMPLETE (PH)		207	1-828-985-11	WIRE (FLAT TYPE) (15 CORE)	
202	A-1189-055-A	MAIN BOARD, COMPLETE (MY,SP)		208	A-1164-101-A	S-MASTER BOARD, COMPLETE	
202	A-1189-058-A	MAIN BOARD, COMPLETE (EA)		△ 209	1-824-642-21	CORD, POWER (WITH CONNECTOR) (TH)	
202	A-1189-061-A	MAIN BOARD, COMPLETE (E12)		△ 209	1-830-188-11	CORD, POWER (EXCEPT TH)	
202	A-1189-064-A	MAIN BOARD, COMPLETE (E15)		210	3-703-244-00	BUSHING (2104), CORD	
202	A-1189-067-A	MAIN BOARD, COMPLETE (E13)		211	3-703-136-12	SCREW, TAPPING	
202	A-1189-077-A	MAIN BOARD, COMPLETE (TH)		FC901	1-500-497-11	FILTER, CLAMP (FERRITE CORE)	
203	A-1164-103-A	ADC BOARD, COMPLETE		#1	7-685-646-79	SCREW +BVTP 3X8 TYPE2 TT (B)	
204	2-630-050-01	+BVTT 3X6 (SUMITITE)					

7-6. DVD BLOCK SECTION

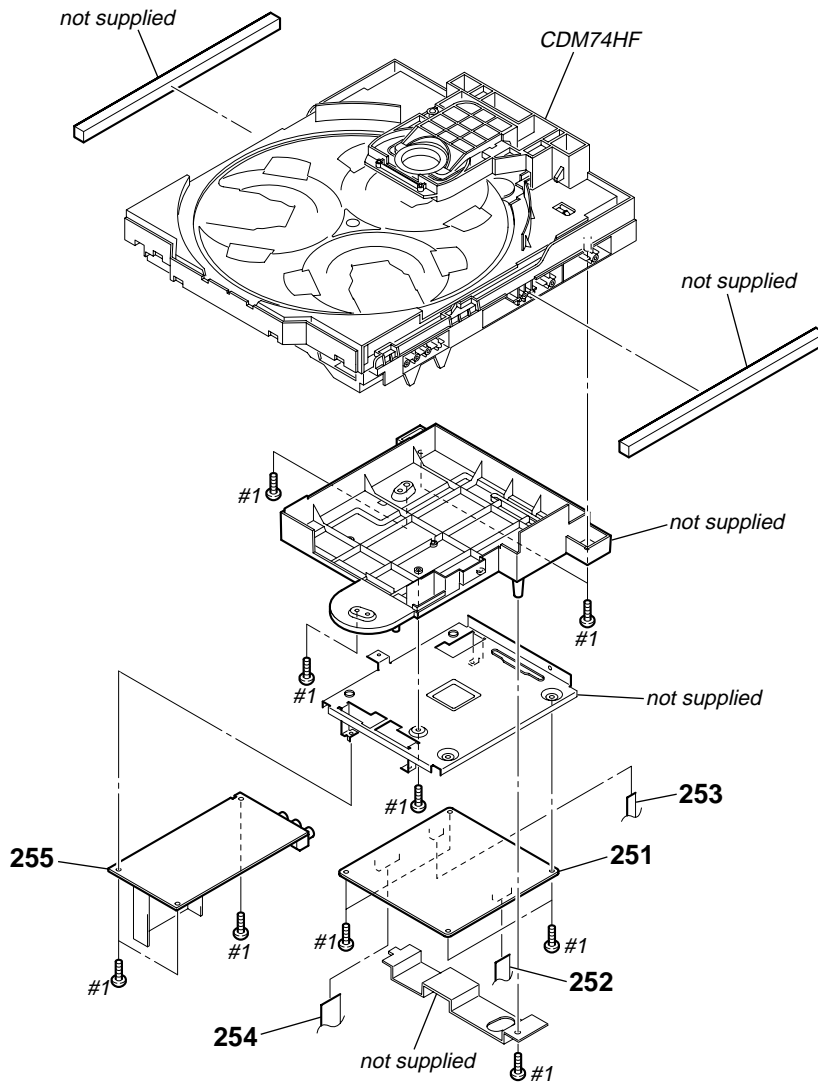

Ref. No.	Part No.	Description	Remark	Ref. No.	Part No.	Description	Remark
☆ 251	A-1167-778-A	DMB15 BOARD, COMPLETE (E3,E12,E13,E15,EA)		253	1-828-286-11	WIRE (FLAT TYPE) (5 CORE)	
☆ 251	A-1188-857-A	DMB15 BOARD, COMPLETE (MY,SP,PH,TH)		254	1-828-614-11	WIRE (FLAT TYPE) (17 CORE)	
252	1-828-589-11	WIRE (FLAT TYPE) (13 CORE)		255	A-1164-023-A	VIDEO BOARD, COMPLETE	
				#1	7-685-646-79	SCREW +BVTP 3X8 TYPE2 TT (B)	

☆ New part of EEPROM (IC103) on the DMB15 board cannot be used. Therefore, if the mounted DMB15 board (A-1167-778-A, etc.) is replaced, exchange new EEPROM (IC103) with that used before the replacement.

7-7. DVD MECHANISM DECK SECTION (1)

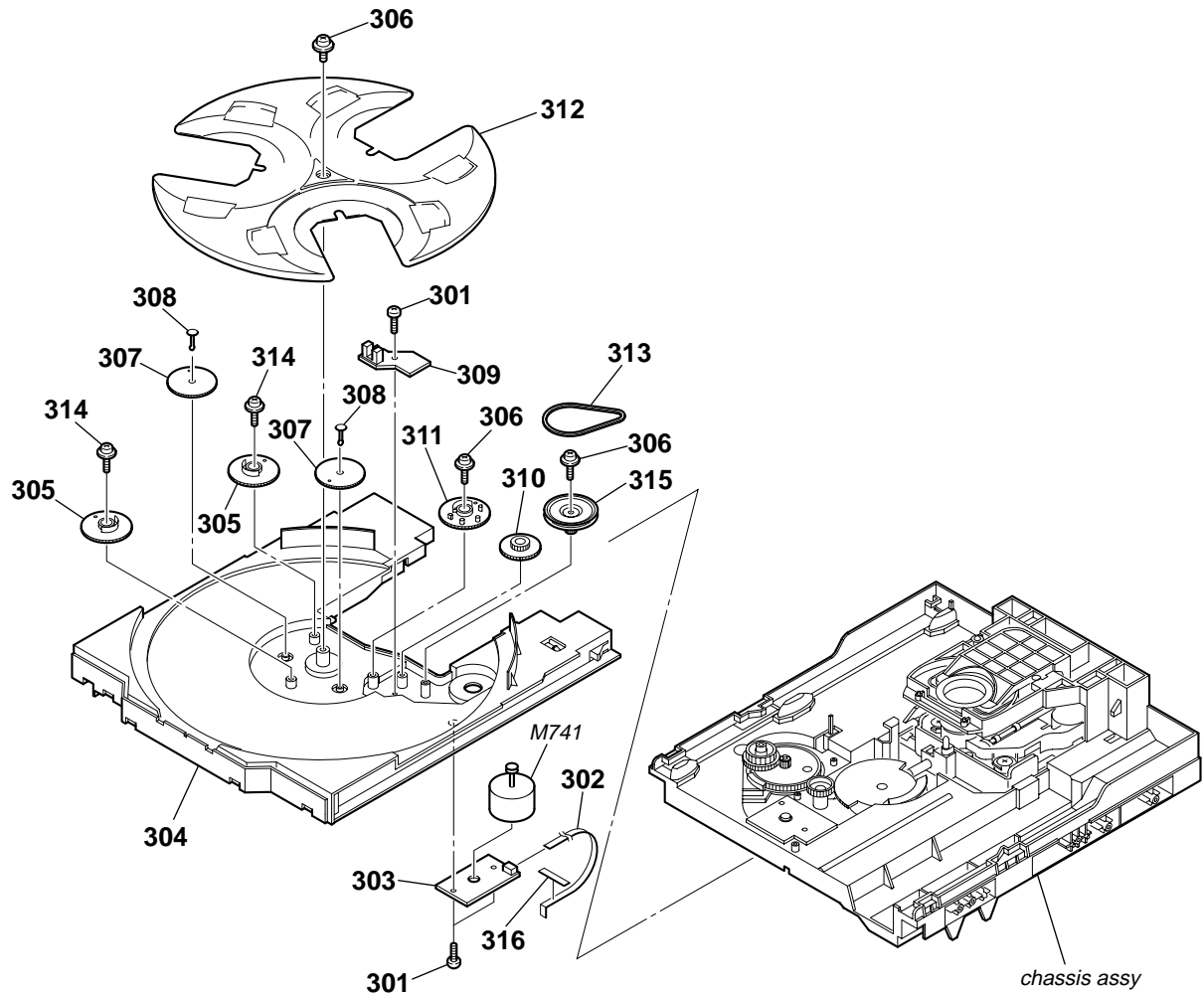

Ref. No.	Part No.	Description	Remark	Ref. No.	Part No.	Description	Remark
301	4-218-253-62	SCREW (M2.6), +BTTP		310	4-243-820-01	GEAR (TABLE)	
302	1-776-182-11	WIRE (FLAT TYPE) (5 CORE)		311	4-243-819-01	GEAR (GENEVA)	
303	1-687-134-12	MOTOR (TB) BOARD		312	4-243-816-21	TRAY	
304	4-243-815-11	TABLE (LOADING)		313	4-243-823-01	BELT (TABLE)	
305	4-245-571-02	GEAR (STOPPER)		314	4-985-672-01	SCREW (+PTPWH M2.6), FLOATING	
306	4-218-252-61	SCREW (+PTPWH M2.6), FLOATING		315	4-243-821-01	PULLEY (TABLE)	
307	4-245-570-01	GEAR (JOINT)		316	3-231-598-01	SHEET (BA)	
308	4-245-572-01	BUSHING (GEAR)		M741	A-1108-965-A	MOTOR ASSY, TABLE (TABLE)	
309	1-687-132-12	SENSOR BOARD					

7-8. DVD MECHANISM DECK SECTION (2)

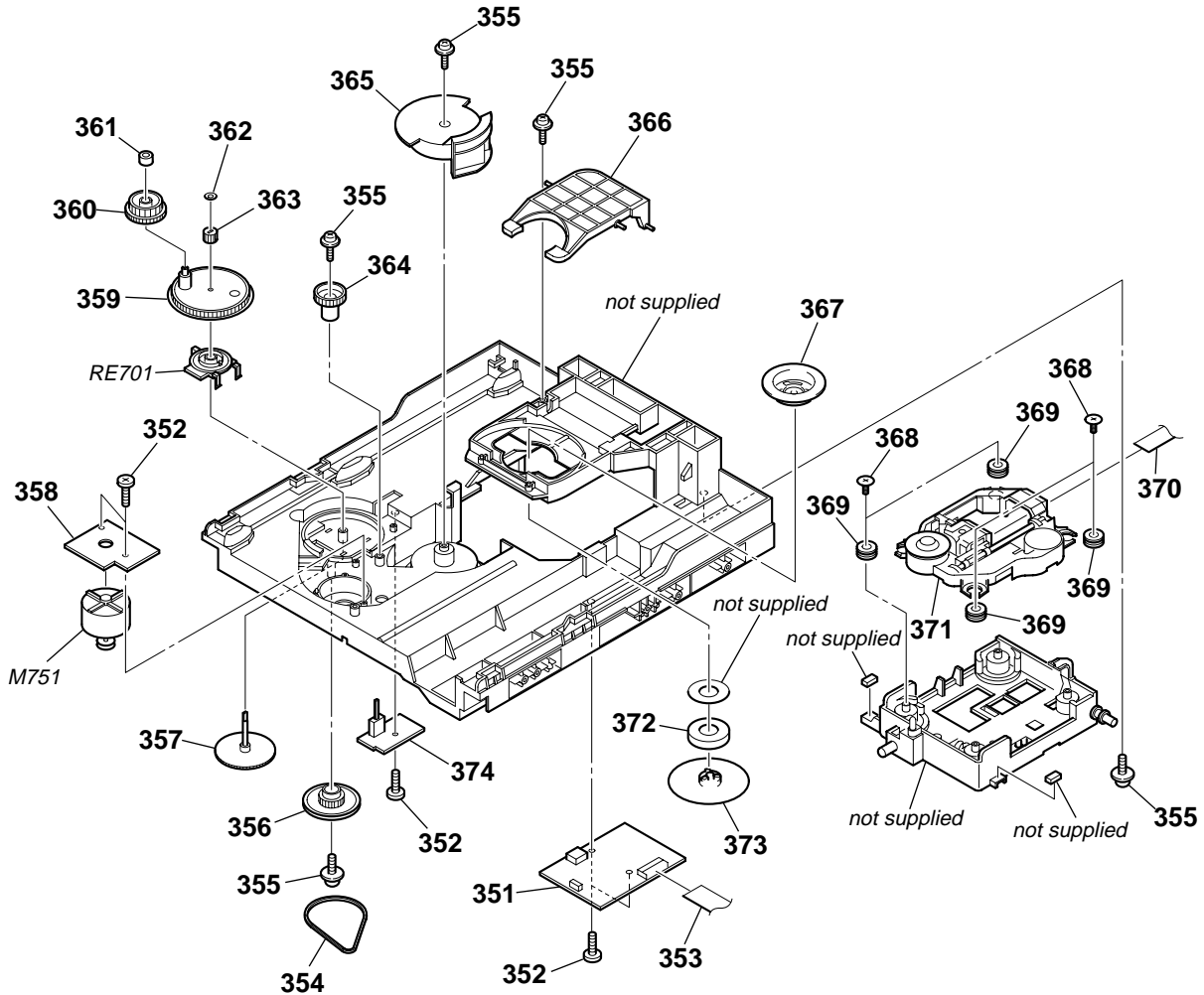

Ref. No.	Part No.	Description	Remark	Ref. No.	Part No.	Description	Remark
351	A-1103-756-B	DRIVER BOARD, COMPLETE		365	4-243-818-01	GEAR (U/D)	
352	4-218-253-52	SCREW (M2.6), +BTTP		366	2-541-918-01	LEVER (LIFTER (H))	
353	1-828-973-11	WIRE (FLAT TYPE) (13 CORE)		367	2-345-983-01	PULLEY B (310), CHUCKING	
354	4-244-034-01	BELT (LOADING)		368	3-087-599-01	SCREW, INSULATOR	
355	4-985-672-01	SCREW (+PTPWH M2.6), FLOATING		369	2-634-618-01	INSULATOR	
356	4-225-844-01	GEAR (LOADING A)		370	1-828-252-51	WIRE (FLAT TYPE) (24 CORE)	
357	4-224-613-01	GEAR (SHAFT)		△371	8-820-291-02	OPTICAL PICK-UP (KHM-310CAB/C2RP)	
358	1-687-133-12	MOTOR (LD) BOARD		372	4-251-923-01	YOKE (310)	
359	4-244-108-01	GEAR, SWING		373	2-345-982-01	PULLEY A (310), CHUCKING	
360	4-224-609-01	GEAR (LOADING C)		374	1-687-669-12	SW BOARD	
361	4-224-608-01	COLLAR, SWING		M751	A-1108-966-A	MOTOR ASSY, LOADING (LOADING)	
362	3-016-533-11	WASHER (FR), STOPPER		RE701	1-477-680-12	ENCODER, ROTARY (DISC TRAY ADDRESS DETECT)	
363	4-224-611-01	GEAR (LOADING B)					
364	4-224-606-01	GEAR (RV)					

SECTION 8 ELECTRICAL PARTS LIST

ADC

NOTE:

- Due to standardization, replacements in the parts list may be different from the parts specified in the diagrams or the components used on the set.
- -XX and -X mean standardized parts, so they may have some difference from the original one.
- RESISTORS
All resistors are in ohms.
METAL: Metal-film resistor.
METAL OXIDE: Metal oxide-film resistor.
F: nonflammable
- Items marked "*" are not stocked since they are seldom required for routine service. Some delay should be anticipated when ordering these items.

- SEMICONDUCTORS
In each case, μ : μ , for example:
uA.. : μ A.. uPA.. : μ PA..
uPB.. : μ PB.. uPC.. : μ PC.. uPD.. : μ PD..
- CAPACITORS
uF : μ F
- COILS
uH : μ H

The components identified by mark Δ or dotted line with mark Δ are critical for safety.
Replace only with part number specified.

When indicating parts by reference number, please include the board.

- Abbreviation
E3 : 240 V AC area in E model
E12 : 220-240 V AC area in E model
E13 : 220-230 V AC area in E model
E15 : Iran model
EA : Saudi Arabia model
MY : Malaysia model
PH : Philippine model
SP : Singapore model
TH : Thai model

Ref. No.	Part No.	Description	Remark	Ref. No.	Part No.	Description	Remark
	A-1164-103-A	ADC BOARD, COMPLETE *****				< GROUND TERMINAL >	
		< CAPACITOR >					
C20	1-126-956-11	ELECT	0.1uF 20% 50V			< FILTER >	
C22	1-104-658-11	ELECT	100uF 20% 10V				
C23	1-107-826-11	CERAMIC CHIP	0.1uF 10% 16V				
C24	1-104-658-11	ELECT	100uF 20% 10V	FL1	1-234-177-21	FILTER, CHIP EMI	
C25	1-107-726-11	CERAMIC CHIP	0.01uF 10% 16V	FL2	1-234-177-21	FILTER, CHIP EMI	
						< IC >	
C26	1-107-826-11	CERAMIC CHIP	0.1uF 10% 16V	IC1	8-759-473-95	IC uPC2905T-E1	
C27	1-126-963-11	ELECT	4.7uF 20% 50V	IC2	8-759-583-47	IC uPC2933T-E2	
C28	1-162-915-11	CERAMIC CHIP	10PF 0.5PF 50V	IC3	8-759-387-77	IC TC7WU04F(TE12R)	
C29	1-162-915-11	CERAMIC CHIP	10PF 0.5PF 50V	IC11	6-707-608-01	IC PCM1803DBR	
C32	1-107-726-11	CERAMIC CHIP	0.01uF 10% 16V			< JUMPER RESISTOR >	
C40	1-164-156-11	CERAMIC CHIP	0.1uF 25V				
C41	1-164-156-11	CERAMIC CHIP	0.1uF 25V	JR51	1-216-806-11	METAL CHIP 56 5% 1/10W	
C42	1-164-156-11	CERAMIC CHIP	0.1uF 25V	JR52	1-216-806-11	METAL CHIP 56 5% 1/10W	
C50	1-164-156-11	CERAMIC CHIP	0.1uF 25V			< COIL >	
C51	1-126-964-11	ELECT	10uF 20% 50V				
C53	1-104-658-11	ELECT	100uF 20% 10V	L1	1-412-939-11	INDUCTOR 1uH	
C54	1-164-156-11	CERAMIC CHIP	0.1uF 25V	L2	1-412-951-11	INDUCTOR 10uH	
C55	1-126-964-11	ELECT	10uF 20% 50V	L3	1-412-951-11	INDUCTOR 10uH	
C56	1-164-156-11	CERAMIC CHIP	0.1uF 25V			< TRANSISTOR >	
C57	1-126-964-11	ELECT	10uF 20% 50V				
C58	1-164-156-11	CERAMIC CHIP	0.1uF 25V	Q7	6-550-889-01	TRANSISTOR 2SC5938-T112-1B	
C59	1-126-960-11	ELECT	1uF 20% 50V	Q8	6-550-889-01	TRANSISTOR 2SC5938-T112-1B	
C60	1-126-960-11	ELECT	1uF 20% 50V			< RESISTOR >	
C81	1-107-726-11	CERAMIC CHIP	0.01uF 10% 16V				
C90	1-162-964-11	CERAMIC CHIP	0.001uF 10% 50V	R25	1-216-825-11	METAL CHIP 2.2K 5% 1/10W	
C91	1-162-964-11	CERAMIC CHIP	0.001uF 10% 50V	R27	1-216-845-11	METAL CHIP 100K 5% 1/10W	
		< CONNECTOR >		R28	1-216-821-11	METAL CHIP 1K 5% 1/10W	
CN1	1-766-720-41	CONNECTOR, BOARD TO BOARD 17P		R29	1-216-825-11	METAL CHIP 2.2K 5% 1/10W	
		< DIODE >		R31	1-216-845-11	METAL CHIP 100K 5% 1/10W	
D11	8-719-988-61	DIODE 1SS355TE-17		R32	1-216-821-11	METAL CHIP 1K 5% 1/10W	
D12	8-719-988-61	DIODE 1SS355TE-17		R36	1-216-864-11	SHORT CHIP 0	
D13	8-719-988-61	DIODE 1SS355TE-17		R38	1-216-864-11	SHORT CHIP 0	
D14	8-719-988-61	DIODE 1SS355TE-17		R40	1-216-821-11	METAL CHIP 1K 5% 1/10W	
D51	8-719-988-61	DIODE 1SS355TE-17		R41	1-216-857-11	METAL CHIP 1M 5% 1/10W	
D52	8-719-988-61	DIODE 1SS355TE-17		R50	1-216-864-11	SHORT CHIP 0	
				R52	1-216-809-11	METAL CHIP 100 5% 1/10W	
				R53	1-216-809-11	METAL CHIP 100 5% 1/10W	
				R55	1-216-864-11	SHORT CHIP 0	
				R58	1-216-864-11	SHORT CHIP 0	

HCD-GNZ55D

Ver. 1.1

ADC DMB15

Ref. No.	Part No.	Description	Remark	Ref. No.	Part No.	Description	Remark
R59	1-216-864-11	SHORT CHIP	0	C156	1-162-970-11	CERAMIC CHIP	0.01uF 10% 25V
R67	1-216-864-11	SHORT CHIP	0	C158	1-162-970-11	CERAMIC CHIP	0.01uF 10% 25V
		< VIBRATOR >		C159	1-162-970-11	CERAMIC CHIP	0.01uF 10% 25V
X1	1-795-843-11	VIBRATOR, CRYSTAL (12.288MHz)		C160	1-162-970-11	CERAMIC CHIP	0.01uF 10% 25V
*****				C161	1-162-970-11	CERAMIC CHIP	0.01uF 10% 25V
☆	A-1167-778-A	DMB15 BOARD, COMPLETE		C162	1-162-970-11	CERAMIC CHIP	0.01uF 10% 25V
		(E3,E12,E13,E15,EA)		C163	1-162-970-11	CERAMIC CHIP	0.01uF 10% 25V
☆	A-1188-857-A	DMB15 BOARD, COMPLETE (MY,SP,PH,TH)		C164	1-162-970-11	CERAMIC CHIP	0.01uF 10% 25V
		*****		C167	1-162-970-11	CERAMIC CHIP	0.01uF 10% 25V
		< CAPACITOR >		C170	1-162-970-11	CERAMIC CHIP	0.01uF 10% 25V
C101	1-162-970-11	CERAMIC CHIP	0.01uF 10% 25V	C171	1-162-970-11	CERAMIC CHIP	0.01uF 10% 25V
C102	1-125-837-11	CERAMIC CHIP	1uF 10% 6.3V	C172	1-162-970-11	CERAMIC CHIP	0.01uF 10% 25V
C105	1-126-205-11	ELECT CHIP	47uF 20% 6.3V	C173	1-162-970-11	CERAMIC CHIP	0.01uF 10% 25V
C106	1-162-970-11	CERAMIC CHIP	0.01uF 10% 25V	C174	1-162-970-11	CERAMIC CHIP	0.01uF 10% 25V
C108	1-162-964-11	CERAMIC CHIP	0.001uF 10% 50V	C175	1-162-970-11	CERAMIC CHIP	0.01uF 10% 25V
C109	1-162-964-11	CERAMIC CHIP	0.001uF 10% 50V	C176	1-162-970-11	CERAMIC CHIP	0.01uF 10% 25V
C112	1-126-205-11	ELECT CHIP	47uF 20% 6.3V	C177	1-126-205-11	ELECT CHIP	47uF 20% 6.3V
C113	1-162-970-11	CERAMIC CHIP	0.01uF 10% 25V	C178	1-126-208-21	ELECT CHIP	47uF 20% 4V
C114	1-107-826-11	CERAMIC CHIP	0.1uF 10% 16V	C179	1-107-826-11	CERAMIC CHIP	0.1uF 10% 16V
C115	1-107-826-11	CERAMIC CHIP	0.1uF 10% 16V	C180	1-107-826-11	CERAMIC CHIP	0.1uF 10% 16V
C116	1-107-826-11	CERAMIC CHIP	0.1uF 10% 16V	C181	1-107-826-11	CERAMIC CHIP	0.1uF 10% 16V
C117	1-124-779-00	ELECT CHIP	10uF 20% 16V	C182	1-127-715-11	CERAMIC CHIP	0.22uF 10% 16V
C118	1-124-779-00	ELECT CHIP	10uF 20% 16V	C184	1-162-970-11	CERAMIC CHIP	0.01uF 10% 25V
C119	1-124-779-00	ELECT CHIP	10uF 20% 16V	C187	1-126-208-21	ELECT CHIP	47uF 20% 4V
C120	1-165-908-11	CERAMIC CHIP	1uF 10% 10V	C188	1-127-715-11	CERAMIC CHIP	0.22uF 10% 16V
C121	1-165-908-11	CERAMIC CHIP	1uF 10% 10V	C189	1-128-934-11	CERAMIC CHIP	0.33uF 20% 10V
C122	1-165-908-11	CERAMIC CHIP	1uF 10% 10V	C190	1-126-205-11	ELECT CHIP	47uF 20% 6.3V
C123	1-165-908-11	CERAMIC CHIP	1uF 10% 10V	C191	1-107-826-11	CERAMIC CHIP	0.1uF 10% 16V
C124	1-165-908-11	CERAMIC CHIP	1uF 10% 10V	C192	1-162-970-11	CERAMIC CHIP	0.01uF 10% 25V
C125	1-107-826-11	CERAMIC CHIP	0.1uF 10% 16V	C193	1-127-715-11	CERAMIC CHIP	0.22uF 10% 16V
C126	1-107-826-11	CERAMIC CHIP	0.1uF 10% 16V	C195	1-127-715-11	CERAMIC CHIP	0.22uF 10% 16V
C127	1-162-970-11	CERAMIC CHIP	0.01uF 10% 25V	C196	1-162-968-11	CERAMIC CHIP	0.0047uF 10% 50V
C128	1-162-965-11	CERAMIC CHIP	0.0015uF 10% 50V	C203	1-162-970-11	CERAMIC CHIP	0.01uF 10% 25V
C129	1-124-779-00	ELECT CHIP	10uF 20% 16V	C205	1-164-230-11	CERAMIC CHIP	220PF 5% 50V
C130	1-107-826-11	CERAMIC CHIP	0.1uF 10% 16V	C206	1-164-230-11	CERAMIC CHIP	220PF 5% 50V
C131	1-125-838-11	CERAMIC CHIP	2.2uF 10% 6.3V	C208	1-162-970-11	CERAMIC CHIP	0.01uF 10% 25V
C132	1-107-826-11	CERAMIC CHIP	0.1uF 10% 16V	C209	1-164-677-11	CERAMIC CHIP	0.033uF 10% 16V
C133	1-107-826-11	CERAMIC CHIP	0.1uF 10% 16V	C210	1-162-970-11	CERAMIC CHIP	0.01uF 10% 25V
C135	1-164-677-11	CERAMIC CHIP	0.033uF 10% 16V	C211	1-164-677-11	CERAMIC CHIP	0.033uF 10% 16V
C136	1-162-970-11	CERAMIC CHIP	0.01uF 10% 25V	C212	1-162-970-11	CERAMIC CHIP	0.01uF 10% 25V
C137	1-107-826-11	CERAMIC CHIP	0.1uF 10% 16V	C213	1-162-970-11	CERAMIC CHIP	0.01uF 10% 25V
C138	1-162-964-11	CERAMIC CHIP	0.001uF 10% 50V	C214	1-162-964-11	CERAMIC CHIP	0.001uF 10% 50V
C139	1-162-919-11	CERAMIC CHIP	22PF 5% 50V	C215	1-162-970-11	CERAMIC CHIP	0.01uF 10% 25V
C140	1-107-826-11	CERAMIC CHIP	0.1uF 10% 16V	C217	1-126-204-11	ELECT CHIP	47uF 20% 16V
C144	1-162-970-11	CERAMIC CHIP	0.01uF 10% 25V	C218	1-124-779-00	ELECT CHIP	10uF 20% 16V
C146	1-107-826-11	CERAMIC CHIP	0.1uF 10% 16V	C219	1-162-970-11	CERAMIC CHIP	0.01uF 10% 25V
C147	1-165-176-11	CERAMIC CHIP	0.047uF 10% 16V	C220	1-124-779-00	ELECT CHIP	10uF 20% 16V
C148	1-165-176-11	CERAMIC CHIP	0.047uF 10% 16V	C221	1-107-826-11	CERAMIC CHIP	0.1uF 10% 16V
C149	1-107-826-11	CERAMIC CHIP	0.1uF 10% 16V	C222	1-107-826-11	CERAMIC CHIP	0.1uF 10% 16V
C150	1-124-779-00	ELECT CHIP	10uF 20% 16V	C224	1-162-970-11	CERAMIC CHIP	0.01uF 10% 25V
C151	1-115-416-11	CERAMIC CHIP	0.001uF 5% 25V	C233	1-162-968-11	CERAMIC CHIP	0.0047uF 10% 50V
C152	1-162-916-11	CERAMIC CHIP	12PF 5% 50V	C301	1-162-970-11	CERAMIC CHIP	0.01uF 10% 25V
C153	1-162-916-11	CERAMIC CHIP	12PF 5% 50V	C302	1-125-891-11	CERAMIC CHIP	0.47uF 10% 10V
C154	1-107-826-11	CERAMIC CHIP	0.1uF 10% 16V	C305	1-125-891-11	CERAMIC CHIP	0.47uF 10% 10V
C155	1-162-970-11	CERAMIC CHIP	0.01uF 10% 25V	C306	1-126-206-11	ELECT CHIP	100uF 20% 6.3V
				C307	1-126-206-11	ELECT CHIP	100uF 20% 6.3V
				C308	1-107-725-11	CERAMIC CHIP	0.1uF 10% 16V
				C402	1-126-204-11	ELECT CHIP	47uF 20% 16V

☆ New part of EEPROM (IC103) on the DMB15 board cannot be used. Therefore, if the mounted DMB15 board (A-1167-778-A, etc.) is replaced, exchange new EEPROM (IC103) with that used before the replacement.

Ref. No.	Part No.	Description	Remark	Ref. No.	Part No.	Description	Remark
C403	1-126-205-11	ELECT CHIP	47uF 20% 6.3V	FL105	1-234-177-21	FILTER, CHIP EMI	
C3701	1-107-826-11	CERAMIC CHIP	0.1uF 10% 16V	FL106	1-234-177-21	FILTER, CHIP EMI	
C3702	1-107-826-11	CERAMIC CHIP	0.1uF 10% 16V	FL107	1-234-177-21	FILTER, CHIP EMI	
C3707	1-107-826-11	CERAMIC CHIP	0.1uF 10% 16V	FL108	1-234-177-21	FILTER, CHIP EMI	
C3708	1-107-826-11	CERAMIC CHIP	0.1uF 10% 16V	FL401	1-234-177-21	FILTER, CHIP EMI	
C3711	1-162-977-11	CERAMIC CHIP	0.0018uF 10% 50V	FL402	1-233-893-21	FILTER, CHIP EMI	
C3712	1-162-966-11	CERAMIC CHIP	0.0022uF 10% 50V	FL403	1-234-177-21	FILTER, CHIP EMI	
C3713	1-162-961-11	CERAMIC CHIP	330PF 10% 50V			< IC >	
C3714	1-162-961-11	CERAMIC CHIP	330PF 10% 50V	IC101	6-806-351-01	IC MX29LV320CBTC70-CBA4-0601CE	
C3721	1-162-977-11	CERAMIC CHIP	0.0018uF 10% 50V			(E3,E12,E13,E15,EA)	
C3722	1-162-966-11	CERAMIC CHIP	0.0022uF 10% 50V	IC101	6-806-352-01	IC MX29LV320CBTC70-CBA4-0601GA	
C3723	1-162-961-11	CERAMIC CHIP	330PF 10% 50V			(MY,SP,PH,TH)	
C3724	1-162-961-11	CERAMIC CHIP	330PF 10% 50V	IC102	6-707-535-01	IC CXD9849R	
C3771	1-162-977-11	CERAMIC CHIP	0.0018uF 10% 50V	☆IC103	not supplied	IC BR24L64F-WE2	
C3772	1-162-966-11	CERAMIC CHIP	0.0022uF 10% 50V	IC104	6-709-370-01	IC A2V64S40CTP-G75	
C3773	1-162-961-11	CERAMIC CHIP	330PF 10% 50V	IC105	6-702-302-01	IC TK11133CSCL-G	
C3774	1-162-961-11	CERAMIC CHIP	330PF 10% 50V	IC106	6-708-153-01	IC PQ018EN01ZPH	
C3781	1-162-977-11	CERAMIC CHIP	0.0018uF 10% 50V	IC107	6-702-302-01	IC TK11133CSCL-G	
C3782	1-162-966-11	CERAMIC CHIP	0.0022uF 10% 50V	IC201	6-704-524-01	IC FAN8036L	
C3783	1-162-961-11	CERAMIC CHIP	330PF 10% 50V	IC301	6-704-222-01	IC AK4358VQ-L	
C3784	1-162-961-11	CERAMIC CHIP	330PF 10% 50V	IC3711	8-759-359-49	IC NJM3414AV(TE2)	
C3801	1-126-206-11	ELECT CHIP	100uF 20% 6.3V	IC3771	8-759-359-49	IC NJM3414AV(TE2)	
C3802	1-117-370-11	CERAMIC CHIP	10uF 10V			< TRANSISTOR >	
C3803	1-126-209-11	ELECT CHIP	100uF 20% 4V	Q101	6-550-008-01	TRANSISTOR UM6K1N-TN	
C3804	1-126-205-11	ELECT CHIP	47uF 20% 6.3V	Q102	6-550-653-01	TRANSISTOR QST8TR	
C3805	1-126-208-21	ELECT CHIP	47uF 20% 4V	Q103	8-729-027-52	TRANSISTOR DTC124EKA-T146	
		< CONNECTOR >		Q3801	8-729-230-49	TRANSISTOR 2SC2712-YG	
CN101	1-815-763-32	CONNECTOR, FFC/FPC 24P				< RESISTOR >	
* CN105	1-770-470-21	PIN, CONNECTOR (PC BOARD) 6P		R101	1-216-809-11	METAL CHIP 100 5% 1/10W	
CN106	1-793-989-21	CONNECTOR, FFC/FPC 13P		R104	1-216-864-11	SHORT CHIP 0	
* CN201	1-770-470-21	PIN, CONNECTOR (PC BOARD) 6P		R105	1-216-833-11	METAL CHIP 10K 5% 1/10W	
CN301	1-784-365-21	CONNECTOR, FFC/FPC 5P		R106	1-216-833-11	METAL CHIP 10K 5% 1/10W	
CN302	1-784-376-11	CONNECTOR, FFC/FPC 17P		R107	1-216-833-11	METAL CHIP 10K 5% 1/10W	
CN401	1-779-993-11	PIN, CONNECTOR (PWB) 5P		R108	1-216-857-11	METAL CHIP 1M 5% 1/10W	
		< DIODE >		R109	1-216-864-11	SHORT CHIP 0	
D1001	8-719-058-24	DIODE RB501V-40TE-17		R110	1-216-841-11	METAL CHIP 47K 5% 1/10W	
D3501	8-719-988-61	DIODE 1SS355TE-17		R111	1-216-809-11	METAL CHIP 100 5% 1/10W	
D3502	8-719-988-61	DIODE 1SS355TE-17		R112	1-211-977-11	METAL CHIP 22 0.5% 1/10W	
		< FERRITE BEAD >		R113	1-211-977-11	METAL CHIP 22 0.5% 1/10W	
FB111	1-414-226-21	INDUCTOR, FERRITE BEAD		R114	1-216-845-11	METAL CHIP 100K 5% 1/10W	
FB112	1-414-226-21	INDUCTOR, FERRITE BEAD		R115	1-211-977-11	METAL CHIP 22 0.5% 1/10W	
FB113	1-414-226-21	INDUCTOR, FERRITE BEAD		R116	1-216-821-11	METAL CHIP 1K 5% 1/10W	
FB114	1-414-226-21	INDUCTOR, FERRITE BEAD		R117	1-216-841-11	METAL CHIP 47K 5% 1/10W	
FB115	1-414-226-21	INDUCTOR, FERRITE BEAD		R118	1-216-801-11	METAL CHIP 22 5% 1/10W	
FB401	1-469-324-21	FERRITE, EMI (SMD) (2012)		R120	1-216-801-11	METAL CHIP 22 5% 1/10W	
FB402	1-469-324-21	FERRITE, EMI (SMD) (2012)		R121	1-216-801-11	METAL CHIP 22 5% 1/10W	
FB403	1-469-324-21	FERRITE, EMI (SMD) (2012)		R123	1-216-864-11	SHORT CHIP 0	
FB404	1-469-324-21	FERRITE, EMI (SMD) (2012)		R124	1-216-841-11	METAL CHIP 47K 5% 1/10W	
FB405	1-469-324-21	FERRITE, EMI (SMD) (2012)		R126	1-216-864-11	SHORT CHIP 0	
FB406	1-469-324-21	FERRITE, EMI (SMD) (2012)		R127	1-216-809-11	METAL CHIP 100 5% 1/10W	
		< FILTER >		R136	1-216-835-11	METAL CHIP 15K 5% 1/10W	
FL101	1-234-177-21	FILTER, CHIP EMI		R138	1-216-845-11	METAL CHIP 100K 5% 1/10W	
FL104	1-234-177-21	FILTER, CHIP EMI		R141	1-218-916-11	METAL CHIP 750K 0.5% 1/10W	
				R142	1-216-845-11	METAL CHIP 100K 5% 1/10W	
				R143	1-216-809-11	METAL CHIP 100 5% 1/10W	

☆ New part of EEPROM (IC103) on the DMB15 board cannot be used.
Therefore, if the mounted DMB15 board (A-1167-778-A, etc.) is replaced,
exchange new EEPROM (IC103) with that used before the replacement.

HCD-GNZ55D

DMB15

Ref. No.	Part No.	Description	Quantity	Percentage	Remark	Ref. No.	Part No.	Description	Quantity	Percentage	Remark
R146	1-216-805-11	METAL CHIP	47	5%	1/10W	R1133	1-216-864-11	SHORT CHIP	0		
R151	1-216-805-11	METAL CHIP	47	5%	1/10W	R1134	1-216-864-11	SHORT CHIP	0		
R152	1-216-864-11	SHORT CHIP	0			R1150	1-216-827-11	METAL CHIP	3.3K	5%	1/10W
R153	1-216-805-11	METAL CHIP	47	5%	1/10W	R1151	1-216-827-11	METAL CHIP	3.3K	5%	1/10W
R155	1-216-805-11	METAL CHIP	47	5%	1/10W	R1152	1-216-827-11	METAL CHIP	3.3K	5%	1/10W
R160	1-216-805-11	METAL CHIP	47	5%	1/10W	R1168	1-216-817-11	METAL CHIP	470	5%	1/10W
R161	1-216-809-11	METAL CHIP	100	5%	1/10W	R1502	1-216-864-11	SHORT CHIP	0		
R164	1-216-809-11	METAL CHIP	100	5%	1/10W	R1504	1-400-244-11	BEAD, FERRITE (CHIP) (1608)			
R169	1-216-833-11	METAL CHIP	10K	5%	1/10W	R1524	1-414-226-21	INDUCTOR, FERRITE BEAD			
R187	1-216-864-11	SHORT CHIP	0			R1526	1-414-226-21	INDUCTOR, FERRITE BEAD			
R189	1-218-827-11	METAL CHIP	150	0.5%	1/10W	R1528	1-216-833-11	METAL CHIP	10K	5%	1/10W
R190	1-218-827-11	METAL CHIP	150	0.5%	1/10W	R1530	1-216-864-11	SHORT CHIP	0		
R191	1-216-821-11	METAL CHIP	1K	5%	1/10W	R1531	1-216-864-11	SHORT CHIP	0		
R192	1-216-827-11	METAL CHIP	150	0.5%	1/10W	R1540	1-216-829-11	METAL CHIP	4.7K	5%	1/10W
R193	1-216-821-11	METAL CHIP	1K	5%	1/10W	R1542	1-216-833-11	METAL CHIP	10K	5%	1/10W
R195	1-218-827-11	METAL CHIP	150	0.5%	1/10W	R1544	1-216-864-11	SHORT CHIP	0		
R196	1-216-864-11	SHORT CHIP	0			R1546	1-216-827-11	METAL CHIP	3.3K	5%	1/10W
R197	1-218-827-11	METAL CHIP	150	0.5%	1/10W	R1547	1-216-829-11	METAL CHIP	4.7K	5%	1/10W
R204	1-216-822-11	METAL CHIP	1.2K	5%	1/10W	R1548	1-216-829-11	METAL CHIP	4.7K	5%	1/10W
R205	1-216-833-11	METAL CHIP	10K	5%	1/10W	R1549	1-216-829-11	METAL CHIP	4.7K	5%	1/10W
R206	1-216-833-11	METAL CHIP	10K	5%	1/10W	R1550	1-216-829-11	METAL CHIP	4.7K	5%	1/10W
R207	1-216-826-11	METAL CHIP	2.7K	5%	1/10W	R1551	1-216-829-11	METAL CHIP	4.7K	5%	1/10W
R208	1-216-839-11	METAL CHIP	33K	5%	1/10W	R1552	1-216-833-11	METAL CHIP	10K	5%	1/10W
R209	1-216-839-11	METAL CHIP	33K	5%	1/10W	R1553	1-216-864-11	SHORT CHIP	0		
R210	1-216-841-11	METAL CHIP	47K	5%	1/10W	R1554	1-216-829-11	METAL CHIP	4.7K	5%	1/10W
R212	1-216-833-11	METAL CHIP	10K	5%	1/10W	R1557	1-216-809-11	METAL CHIP	100	5%	1/10W
R213	1-218-867-11	METAL CHIP	6.8K	0.5%	1/10W	R1558	1-216-833-11	METAL CHIP	10K	5%	1/10W
R214	1-216-835-11	METAL CHIP	15K	5%	1/10W	R2504	1-216-829-11	METAL CHIP	4.7K	5%	1/10W
R215	1-216-834-11	METAL CHIP	12K	5%	1/10W	R3501	1-216-864-11	SHORT CHIP	0		
R216	1-216-834-11	METAL CHIP	12K	5%	1/10W	R3651	1-216-864-11	SHORT CHIP	0		
R219	1-216-838-11	METAL CHIP	27K	5%	1/10W	R3652	1-216-864-11	SHORT CHIP	0		
R220	1-216-833-11	METAL CHIP	10K	5%	1/10W	R3653	1-216-864-11	SHORT CHIP	0		
R221	1-218-889-11	METAL CHIP	56K	0.5%	1/10W	R3711	1-216-823-11	METAL CHIP	1.5K	5%	1/10W
R223	1-218-895-11	METAL CHIP	100K	0.5%	1/10W	R3712	1-216-823-11	METAL CHIP	1.5K	5%	1/10W
R224	1-216-833-11	METAL CHIP	10K	5%	1/10W	R3713	1-216-828-11	METAL CHIP	3.9K	5%	1/10W
R225	1-218-895-11	METAL CHIP	100K	0.5%	1/10W	R3714	1-216-828-11	METAL CHIP	3.9K	5%	1/10W
R226	1-218-889-11	METAL CHIP	56K	0.5%	1/10W	R3715	1-216-829-11	METAL CHIP	4.7K	5%	1/10W
R230	1-218-893-11	METAL CHIP	82K	0.5%	1/10W	R3716	1-216-821-11	METAL CHIP	1K	5%	1/10W
R231	1-218-875-11	METAL CHIP	15K	0.5%	1/10W	R3717	1-216-821-11	METAL CHIP	1K	5%	1/10W
R232	1-218-877-11	METAL CHIP	18K	0.5%	1/10W	R3718	1-216-829-11	METAL CHIP	4.7K	5%	1/10W
R233	1-218-883-11	METAL CHIP	33K	0.5%	1/10W	R3719	1-216-821-11	METAL CHIP	1K	5%	1/10W
R234	1-216-833-11	METAL CHIP	10K	5%	1/10W	R3721	1-216-823-11	METAL CHIP	1.5K	5%	1/10W
R246	1-216-829-11	METAL CHIP	4.7K	5%	1/10W	R3722	1-216-823-11	METAL CHIP	1.5K	5%	1/10W
R247	1-216-821-11	METAL CHIP	1K	5%	1/10W	R3723	1-216-828-11	METAL CHIP	3.9K	5%	1/10W
R314	1-216-809-11	METAL CHIP	100	5%	1/10W	R3724	1-216-828-11	METAL CHIP	3.9K	5%	1/10W
R319	1-216-864-11	SHORT CHIP	0			R3725	1-216-829-11	METAL CHIP	4.7K	5%	1/10W
R1101	1-216-825-11	METAL CHIP	2.2K	5%	1/10W	R3726	1-216-821-11	METAL CHIP	1K	5%	1/10W
R1102	1-218-827-11	METAL CHIP	150	0.5%	1/10W	R3727	1-216-821-11	METAL CHIP	1K	5%	1/10W
R1103	1-216-833-11	METAL CHIP	10K	5%	1/10W	R3728	1-216-829-11	METAL CHIP	4.7K	5%	1/10W
R1104	1-216-833-11	METAL CHIP	10K	5%	1/10W	R3729	1-216-821-11	METAL CHIP	1K	5%	1/10W
R1105	1-216-833-11	METAL CHIP	10K	5%	1/10W	R3771	1-216-823-11	METAL CHIP	1.5K	5%	1/10W
R1108	1-216-864-11	SHORT CHIP	0			R3772	1-216-823-11	METAL CHIP	1.5K	5%	1/10W
R1109	1-216-864-11	SHORT CHIP	0			R3773	1-216-828-11	METAL CHIP	3.9K	5%	1/10W
R1110	1-216-826-11	METAL CHIP	2.7K	5%	1/10W	R3774	1-216-828-11	METAL CHIP	3.9K	5%	1/10W
R1123	1-216-864-11	SHORT CHIP	0			R3775	1-216-829-11	METAL CHIP	4.7K	5%	1/10W
R1124	1-216-864-11	SHORT CHIP	0			R3776	1-216-821-11	METAL CHIP	1K	5%	1/10W
R1125	1-216-864-11	SHORT CHIP	0			R3777	1-216-821-11	METAL CHIP	1K	5%	1/10W
R1129	1-216-845-11	METAL CHIP	100K	5%	1/10W	R3778	1-216-829-11	METAL CHIP	4.7K	5%	1/10W

Ref. No.	Part No.	Description	Remark	Ref. No.	Part No.	Description	Remark
R3779	1-216-821-11	METAL CHIP	1K 5% 1/10W	D711	8-719-109-69	DIODE RD3.6ESB2	
R3781	1-216-823-11	METAL CHIP	1.5K 5% 1/10W			< IC >	
R3782	1-216-823-11	METAL CHIP	1.5K 5% 1/10W	IC701	8-759-598-69	IC BA6956AN	
R3783	1-216-828-11	METAL CHIP	3.9K 5% 1/10W	IC712	8-759-598-69	IC BA6956AN	
R3784	1-216-828-11	METAL CHIP	3.9K 5% 1/10W			< TRANSISTOR >	
R3785	1-216-829-11	METAL CHIP	4.7K 5% 1/10W	Q731	8-729-029-66	TRANSISTOR DTC114ESA	
R3786	1-216-821-11	METAL CHIP	1K 5% 1/10W			< RESISTOR >	
R3787	1-216-821-11	METAL CHIP	1K 5% 1/10W	R701	1-249-413-11	CARBON 470 5% 1/4W	
R3788	1-216-829-11	METAL CHIP	4.7K 5% 1/10W	R702	1-247-807-31	CARBON 100 5% 1/4W	
R3789	1-216-821-11	METAL CHIP	1K 5% 1/10W	R711	1-249-417-11	CARBON 1K 5% 1/4W	
R3801	1-216-864-11	SHORT CHIP	0	R712	1-249-425-11	CARBON 4.7K 5% 1/4W	
R3802	1-216-864-11	SHORT CHIP	0	R713	1-249-433-11	CARBON 22K 5% 1/4W	
R3803	1-216-833-11	METAL CHIP	10K 5% 1/10W	R721	1-249-425-11	CARBON 4.7K 5% 1/4W	
R3804	1-216-836-11	METAL CHIP	18K 5% 1/10W	R722	1-249-425-11	CARBON 4.7K 5% 1/4W	
R3805	1-216-821-11	METAL CHIP	1K 5% 1/10W	R723	1-249-425-11	CARBON 4.7K 5% 1/4W	
R4704	1-216-864-11	SHORT CHIP	0	R731	1-247-807-31	CARBON 100 5% 1/4W	
R4705	1-216-864-11	SHORT CHIP	0	R732	1-249-429-11	CARBON 10K 5% 1/4W	
R4706	1-216-864-11	SHORT CHIP	0	R733	1-249-417-11	CARBON 1K 5% 1/4W	
R5001	1-216-864-11	SHORT CHIP	0	R734	1-249-430-11	CARBON 12K 5% 1/4W	
R5012	1-216-864-11	SHORT CHIP	0	R736	1-249-412-11	CARBON 390 5% 1/4W	
R5016	1-216-864-11	SHORT CHIP	0	R751	1-249-425-11	CARBON 4.7K 5% 1/4W	
		< NETWORK RESISTOR >		*****			
RB103	1-234-795-21	RES, NETWORK 0X4 (2010)				IR BOARD	
RB104	1-234-795-21	RES, NETWORK 0X4 (2010)				*****	
RB105	1-234-371-21	RES, NETWORK 47X4 (1005)				< CAPACITOR >	
RB106	1-234-371-21	RES, NETWORK 47X4 (1005)		C1308	1-115-416-11	CERAMIC CHIP 0.001uF 5% 25V	
RB107	1-234-370-21	RES, NETWORK 22X4 (1005)				< CONNECTOR >	
RB108	1-234-370-21	RES, NETWORK 22X4 (1005)		CN1403	1-816-423-11	SOCKET, CONNECTOR 3P	
RB111	1-234-795-21	RES, NETWORK 0X4 (2010)				< IC >	
RB112	1-234-370-21	RES, NETWORK 22X4 (1005)		IC1301	6-600-309-01	IC RPM7240-H9 (IR)	
RB113	1-234-370-21	RES, NETWORK 22X4 (1005)				< RESISTOR >	
		< VIBRATOR >		R1306	1-216-805-11	METAL CHIP 47 5% 1/10W	
X101	1-781-867-21	VIBRATOR, CRYSTAL (27MHz)		*****			
		*****				A-1159-563-A MAIN BOARD, COMPLETE (E3)	
	A-1103-756-B	DRIVER BOARD, COMPLETE				A-1189-052-A MAIN BOARD, COMPLETE (PH)	
		*****				A-1189-055-A MAIN BOARD, COMPLETE (MY,SP)	
		< CAPACITOR >				A-1189-058-A MAIN BOARD, COMPLETE (EA)	
C715	1-126-933-11	ELECT 100uF 20% 16V				A-1189-061-A MAIN BOARD, COMPLETE (E12)	
C731	1-126-964-11	ELECT 10uF 20% 50V				A-1189-064-A MAIN BOARD, COMPLETE (E15)	
C735	1-164-159-21	CERAMIC 0.1uF 50V				A-1189-067-A MAIN BOARD, COMPLETE (E13)	
C736	1-164-159-21	CERAMIC 0.1uF 50V				A-1189-077-A MAIN BOARD, COMPLETE (TH)	
C737	1-164-159-21	CERAMIC 0.1uF 50V				*****	
C741	1-162-306-11	CERAMIC 0.01uF 20% 16V				7-685-646-79 SCREW +BVTP 3X8 TYPE2 TT (B)	
C751	1-162-306-11	CERAMIC 0.01uF 20% 16V				< CAPACITOR >	
C752	1-164-159-21	CERAMIC 0.1uF 50V				C101	1-126-964-11 ELECT 10uF 20% 50V
		< CONNECTOR >				C102	1-126-964-11 ELECT 10uF 20% 50V
CN701	1-784-735-11	CONNECTOR, FFC 13P				C103	1-126-964-11 ELECT 10uF 20% 50V
CN702	1-784-766-11	CONNECTOR, FFC 5P					
* CN703	1-564-720-11	PIN, CONNECTOR (SMALL TYPE) 4P					
CN704	1-785-328-11	PIN, CONNECTOR (LIGHT ANGLE) 2P					
		< DIODE >					
D701	8-719-921-42	DIODE MTZJ-5.1A					

HCD-GNZ55D

MAIN

Ref. No.	Part No.	Description			Remark	Ref. No.	Part No.	Description			Remark
C104	1-126-964-11	ELECT	10uF	20%	50V	C172	1-126-964-11	ELECT	10uF	20%	50V
C105	1-126-964-11	ELECT	10uF	20%	50V	C173	1-162-957-11	CERAMIC CHIP	220PF	5%	50V
C106	1-115-412-11	CERAMIC CHIP	680PF	5%	25V	C174	1-162-928-11	CERAMIC CHIP	120PF	5%	50V
C107	1-136-497-81	FILM	0.1uF	5%	50V	C175	1-162-959-11	CERAMIC CHIP	330PF	5%	50V
C108	1-104-700-11	CERAMIC CHIP	0.027uF	10%	16V	C176	1-162-964-11	CERAMIC CHIP	0.001uF	10%	50V
C109	1-104-700-11	CERAMIC CHIP	0.027uF	10%	16V	C177	1-137-194-81	FILM	0.47uF	5%	50V
C110	1-126-964-11	ELECT	10uF	20%	50V	C178	1-162-970-11	CERAMIC CHIP	0.01uF	10%	25V
C111	1-135-995-11	CERAMIC CHIP	0.039uF	10%	25V	C179	1-162-970-11	CERAMIC CHIP	0.01uF	10%	25V
C112	1-162-969-11	CERAMIC CHIP	0.0068uF	10%	25V	C180	1-164-172-11	CERAMIC CHIP	0.0056uF	10%	25V
C113	1-126-964-11	ELECT	10uF	20%	50V	C184	1-162-927-11	CERAMIC CHIP	100PF	5%	50V
C114	1-137-194-81	FILM	0.47uF	5%	50V	C185	1-162-927-11	CERAMIC CHIP	100PF	5%	50V
C115	1-137-194-81	FILM	0.47uF	5%	50V	C186	1-110-563-11	CERAMIC CHIP	0.068uF	10%	16V
C116	1-126-963-11	ELECT	4.7uF	20%	50V	C187	1-104-658-11	ELECT	100uF	20%	10V
C118	1-162-962-11	CERAMIC CHIP	470PF	10%	50V	C188	1-163-077-00	CERAMIC CHIP	0.1uF	10%	25V
C119	1-126-964-11	ELECT	10uF	20%	50V	C189	1-162-957-11	CERAMIC CHIP	220PF	5%	50V
C120	1-162-970-11	CERAMIC CHIP	0.01uF	10%	25V	C190	1-162-957-11	CERAMIC CHIP	220PF	5%	50V
C121	1-126-960-11	ELECT	1uF	20%	50V	C191	1-137-190-11	FILM	0.22uF	5%	50V
C122	1-126-964-11	ELECT	10uF	20%	50V	C192	1-126-960-11	ELECT	1uF	20%	50V
C123	1-162-957-11	CERAMIC CHIP	220PF	5%	50V	C193	1-137-190-11	FILM	0.22uF	5%	50V
C124	1-162-928-11	CERAMIC CHIP	120PF	5%	50V	C194	1-126-964-11	ELECT	10uF	20%	50V
C125	1-162-959-11	CERAMIC CHIP	330PF	5%	50V	C195	1-126-960-11	ELECT	1uF	20%	50V
C126	1-162-964-11	CERAMIC CHIP	0.001uF	10%	50V	C197	1-162-968-11	CERAMIC CHIP	0.0047uF	10%	50V
C130	1-164-172-11	CERAMIC CHIP	0.0056uF	10%	25V	C198	1-126-961-11	ELECT	2.2uF	20%	50V
C132	1-126-933-11	ELECT	100uF	20%	16V	C199	1-162-966-11	CERAMIC CHIP	0.0022uF	10%	50V
C133	1-126-960-11	ELECT	1uF	20%	50V	C200	1-162-966-11	CERAMIC CHIP	0.0022uF	10%	50V
C134	1-162-927-11	CERAMIC CHIP	100PF	5%	50V	C201	1-162-953-11	CERAMIC CHIP	100PF	5%	50V
C135	1-162-927-11	CERAMIC CHIP	100PF	5%	50V	C202	1-162-970-11	CERAMIC CHIP	0.01uF	10%	25V
C136	1-126-933-11	ELECT	100uF	20%	16V	C203	1-162-953-11	CERAMIC CHIP	100PF	5%	50V
C137	1-126-935-11	ELECT	470uF	20%	16V	C204	1-162-953-11	CERAMIC CHIP	100PF	5%	50V
C138	1-162-968-11	CERAMIC CHIP	0.0047uF	10%	50V	C213	1-136-497-81	FILM	0.1uF	5%	50V
C139	1-137-150-11	FILM	0.01uF	5%	100V	C214	1-136-497-81	FILM	0.1uF	5%	50V
C140	1-126-947-11	ELECT	47uF	20%	35V	C215	1-126-964-11	ELECT	10uF	20%	50V
C141	1-162-970-11	CERAMIC CHIP	0.01uF	10%	25V	C216	1-136-497-81	FILM	0.1uF	5%	50V
C142	1-130-481-00	MYLAR	0.0068uF	5%	50V	C226	1-162-953-11	CERAMIC CHIP	100PF	5%	50V
C144	1-162-968-11	CERAMIC CHIP	0.0047uF	10%	50V	C228	1-162-953-11	CERAMIC CHIP	100PF	5%	50V
C145	1-162-968-11	CERAMIC CHIP	0.0047uF	10%	50V	C230	1-126-961-11	ELECT	2.2uF	20%	50V
C147	1-162-968-11	CERAMIC CHIP	0.0047uF	10%	50V	C234	1-126-926-11	ELECT	1000uF	20%	10V
C148	1-126-961-11	ELECT	2.2uF	20%	50V	C235	1-216-864-11	SHORT CHIP	0		
C150	1-126-964-11	ELECT	10uF	20%	50V	C238	1-126-964-11	ELECT	10uF	20%	50V
C151	1-126-964-11	ELECT	10uF	20%	50V	C239	1-126-964-11	ELECT	10uF	20%	50V
C152	1-126-964-11	ELECT	10uF	20%	50V	C288	1-126-964-11	ELECT	10uF	20%	50V
C153	1-126-964-11	ELECT	10uF	20%	50V	C289	1-126-964-11	ELECT	10uF	20%	50V
C154	1-126-964-11	ELECT	10uF	20%	50V	C301	1-126-965-11	ELECT	22uF	20%	50V
C156	1-115-412-11	CERAMIC CHIP	680PF	5%	25V	C302	1-126-965-11	ELECT	22uF	20%	50V
C157	1-136-497-81	FILM	0.1uF	5%	50V	C303	1-126-961-11	ELECT	2.2uF	20%	50V
C158	1-104-700-11	CERAMIC CHIP	0.027uF	10%	16V	C304	1-126-961-11	ELECT	2.2uF	20%	50V
C159	1-104-700-11	CERAMIC CHIP	0.027uF	10%	16V	C307	1-126-961-11	ELECT	2.2uF	20%	50V
C160	1-126-964-11	ELECT	10uF	20%	50V	C308	1-126-961-11	ELECT	2.2uF	20%	50V
C161	1-135-995-11	CERAMIC CHIP	0.039uF	10%	25V	C410	1-162-919-11	CERAMIC CHIP	22PF	5%	50V
C162	1-162-969-11	CERAMIC CHIP	0.0068uF	10%	25V	C411	1-162-918-11	CERAMIC CHIP	18PF	5%	50V
C163	1-126-964-11	ELECT	10uF	20%	50V	C412	1-164-156-11	CERAMIC CHIP	0.1uF		25V
C164	1-137-194-81	FILM	0.47uF	5%	50V	C414	1-164-156-11	CERAMIC CHIP	0.1uF		25V
C165	1-137-194-81	FILM	0.47uF	5%	50V	C416	1-126-917-11	ELECT	3300uF	20%	6.3V
C166	1-126-963-11	ELECT	4.7uF	20%	50V	C462	1-104-658-11	ELECT	100uF	20%	10V
C168	1-162-962-11	CERAMIC CHIP	470PF	10%	50V	C464	1-164-156-11	CERAMIC CHIP	0.1uF		25V
C169	1-126-964-11	ELECT	10uF	20%	50V	C486	1-126-935-11	ELECT	470uF	20%	16V
C170	1-162-970-11	CERAMIC CHIP	0.01uF	10%	25V	C496	1-126-964-11	ELECT	10uF	20%	50V
C171	1-126-960-11	ELECT	1uF	20%	50V	C498	1-164-156-11	CERAMIC CHIP	0.1uF		25V

Ref. No.	Part No.	Description	Remark	Ref. No.	Part No.	Description	Remark
C499	1-164-156-11	CERAMIC CHIP	0.1uF	25V		< FERRITE BEAD >	
C501	1-164-156-11	CERAMIC CHIP	0.1uF	25V			
C502	1-104-658-11	ELECT	100uF	20%	10V		
C504	1-126-926-11	ELECT	1000uF	20%	10V		
C532	1-107-826-11	CERAMIC CHIP	0.1uF	10%	16V		
C539	1-164-156-11	CERAMIC CHIP	0.1uF	25V			
C550	1-128-547-11	ELECT	6800uF	20%	16V		
C551	1-126-960-11	ELECT	1uF	20%	50V		
C552	1-126-925-11	ELECT	470uF	20%	10V		
C553	1-126-960-11	ELECT	1uF	20%	50V		
C554	1-126-925-11	ELECT	470uF	20%	10V		
C555	1-107-826-11	CERAMIC CHIP	0.1uF	10%	16V		
C556	1-107-826-11	CERAMIC CHIP	0.1uF	10%	16V		
C566	1-126-960-11	ELECT	1uF	20%	50V		
C567	1-107-826-11	CERAMIC CHIP	0.1uF	10%	16V		
C568	1-126-916-11	ELECT	1000uF	20%	6.3V		
C582	1-128-547-11	ELECT	6800uF	20%	16V		
C585	1-164-156-11	CERAMIC CHIP	0.1uF	25V			
		< CONNECTOR >					
CN101	1-568-830-11	CONNECTOR, FFC 11P					
CN105	1-784-776-11	CONNECTOR, FFC 15P					
CN121	1-564-705-11	PIN, CONNECTOR (SMALL TYPE) 3P					
* CN131	1-564-710-11	PIN, CONNECTOR (SMALL TYPE) 8P					
CN201	1-784-786-11	CONNECTOR, FFC 25P					
CN205	1-785-318-11	PIN, CONNECTOR (STRAIGHT) 6P					
CN301	1-779-281-11	CONNECTOR, FFC (LIF(NON-ZIF)) 13P					
* CN381	1-766-718-21	CONNECTOR, BOARD TO BOARD 17P					
CN405	1-784-774-11	CONNECTOR, FFC 13P					
CN406	1-568-828-11	CONNECTOR, FFC 9P					
CN521	1-779-285-11	CONNECTOR, FFC (LIF(NON-ZIF)) 17P					
* CN590	1-564-510-11	PLUG, CONNECTOR 7P					
		< DIODE >					
D101	6-501-193-01	DIODE 1SS355WTE-17					
D102	6-501-193-01	DIODE 1SS355WTE-17					
D104	6-501-193-01	DIODE 1SS355WTE-17					
D134	6-500-522-21	DIODE 10EDB40-TB3					
D135	6-500-522-21	DIODE 10EDB40-TB3					
D136	8-719-069-55	DIODE UDZSTE-175.6B					
D213	6-501-193-01	DIODE 1SS355WTE-17					
D214	6-501-193-01	DIODE 1SS355WTE-17					
D215	6-501-193-01	DIODE 1SS355WTE-17					
D216	6-501-193-01	DIODE 1SS355WTE-17					
D230	6-501-193-01	DIODE 1SS355WTE-17					
D231	6-501-193-01	DIODE 1SS355WTE-17					
D232	6-501-193-01	DIODE 1SS355WTE-17					
D393	6-501-193-01	DIODE 1SS355WTE-17					
D394	6-501-193-01	DIODE 1SS355WTE-17					
D395	6-501-193-01	DIODE 1SS355WTE-17					
D396	6-501-193-01	DIODE 1SS355WTE-17					
D486	6-501-193-01	DIODE 1SS355WTE-17					
D505	6-501-193-01	DIODE 1SS355WTE-17					
D506	6-501-193-01	DIODE 1SS355WTE-17					
D583	8-719-978-33	DIODE DTZ-TT11-6.8B					
D594	6-500-522-21	DIODE 10EDB40-TB3					
FB101	1-216-864-11	SHORT CHIP	0				
FB102	1-469-125-21	FERRITE, EMI (SMD) (1608)					
FB103	1-216-864-11	SHORT CHIP	0				
FB104	1-469-125-21	FERRITE, EMI (SMD) (1608)					
FB151	1-216-864-11	SHORT CHIP	0				
FB152	1-469-125-21	FERRITE, EMI (SMD) (1608)					
FB153	1-216-864-11	SHORT CHIP	0				
FB513	1-414-235-22	INDUCTOR, FERRITE BEAD					
FB514	1-414-235-22	INDUCTOR, FERRITE BEAD					
FB515	1-414-235-22	INDUCTOR, FERRITE BEAD					
FB516	1-216-864-11	SHORT CHIP	0				
		< IC >					
IC101	6-705-667-01	IC M61537FP-RF0G					
IC401	6-806-202-01	IC M30622MEP-A50FPU0					
IC402	6-701-680-01	IC PST3629NR					
IC403	6-707-095-01	IC BH2210FV-E2					
IC508	6-600-465-11	IC TOTX147 (DVD DIGITAL OUT)					
IC551	6-703-550-01	IC TA7809LS					
IC552	6-703-550-01	IC TA7809LS					
IC562	6-703-546-01	IC TA7804LS					
		< CONNECTOR >					
J506	1-820-048-11	CONNECTOR (LIGHTING) (D-LIGHT SYNC OUT)					
		< JUMPER RESISTOR >					
JR001	1-216-296-11	SHORT CHIP	0				
JR002	1-216-864-11	SHORT CHIP	0				
JR003	1-216-864-11	SHORT CHIP	0				
JR004	1-216-864-11	SHORT CHIP	0				
JR005	1-216-864-11	SHORT CHIP	0				
JR006	1-216-864-11	SHORT CHIP	0				
JR007	1-216-864-11	SHORT CHIP	0				
JR008	1-216-864-11	SHORT CHIP	0				
JR009	1-216-864-11	SHORT CHIP	0				
JR011	1-216-864-11	SHORT CHIP	0				
JR012	1-216-864-11	SHORT CHIP	0				
JR013	1-216-296-11	SHORT CHIP	0				
JR014	1-216-296-11	SHORT CHIP	0				
JR015	1-216-864-11	SHORT CHIP	0				
JR016	1-216-864-11	SHORT CHIP	0				
JR017	1-216-864-11	SHORT CHIP	0				
JR018	1-216-864-11	SHORT CHIP	0				
JR019	1-216-864-11	SHORT CHIP	0				
JR021	1-216-296-11	SHORT CHIP	0				
JR022	1-216-864-11	SHORT CHIP	0				
JR023	1-216-864-11	SHORT CHIP	0				
JR026	1-216-864-11	SHORT CHIP	0				
JR027	1-216-864-11	SHORT CHIP	0				
JR028	1-216-864-11	SHORT CHIP	0				
JR029	1-216-864-11	SHORT CHIP	0				
JR030	1-216-864-11	SHORT CHIP	0				
JR031	1-216-864-11	SHORT CHIP	0				
JR032	1-216-864-11	SHORT CHIP	0				
JR033	1-216-864-11	SHORT CHIP	0				
JR036	1-216-864-11	SHORT CHIP	0				

HCD-GNZ55D

MAIN

Ref. No.	Part No.	Description	Remark	Ref. No.	Part No.	Description	Remark
JR037	1-216-864-11	SHORT CHIP	0	Q122	8-729-903-46	TRANSISTOR 2SB1132-P	
JR042	1-216-864-11	SHORT CHIP	0	Q123	8-729-027-43	TRANSISTOR DTC114EKA-T146	
JR043	1-216-864-11	SHORT CHIP	0	Q125	8-729-802-80	TRANSISTOR 2SC3661	
JR044	1-216-864-11	SHORT CHIP	0	Q131	8-729-056-46	TRANSISTOR 2SC5053T100Q	
JR047	1-216-864-11	SHORT CHIP	0	Q132	8-729-027-43	TRANSISTOR DTC114EKA-T146	
JR049	1-216-864-11	SHORT CHIP	0	Q133	8-729-027-43	TRANSISTOR DTC114EKA-T146	
JR050	1-216-864-11	SHORT CHIP	0	Q151	8-729-901-81	TRANSISTOR 2SC2412K-T-146-R	
JR051	1-216-864-11	SHORT CHIP	0	Q153	8-729-802-80	TRANSISTOR 2SC3661	
JR052	1-216-864-11	SHORT CHIP	0	Q154	8-729-802-80	TRANSISTOR 2SC3661	
JR053	1-216-864-11	SHORT CHIP	0	Q155	8-729-802-80	TRANSISTOR 2SC3661	
JR054	1-216-864-11	SHORT CHIP	0	Q166	8-729-802-80	TRANSISTOR 2SC3661	
JR055	1-216-296-11	SHORT CHIP	0	Q175	8-729-802-80	TRANSISTOR 2SC3661	
JR056	1-216-296-11	SHORT CHIP	0	Q213	8-729-901-00	TRANSISTOR DTC124EK	
JR057	1-216-296-11	SHORT CHIP	0	Q237	8-729-802-80	TRANSISTOR 2SC3661	
JR059	1-216-296-11	SHORT CHIP	0	Q238	8-729-802-80	TRANSISTOR 2SC3661	
JR125	1-216-864-11	SHORT CHIP	0	Q287	8-729-802-80	TRANSISTOR 2SC3661	
JR152	1-216-296-11	SHORT CHIP	0	Q288	8-729-802-80	TRANSISTOR 2SC3661	
JR175	1-216-864-11	SHORT CHIP	0	Q301	8-729-027-31	TRANSISTOR DTA124EKA-T146	
JR228	1-216-864-11	SHORT CHIP	0	Q302	8-729-027-43	TRANSISTOR DTC114EKA-T146	
JR315	1-216-864-11	SHORT CHIP	0	Q303	8-729-027-31	TRANSISTOR DTA124EKA-T146	
JR316	1-216-864-11	SHORT CHIP	0	Q304	8-729-027-43	TRANSISTOR DTC114EKA-T146	
JR318	1-216-864-11	SHORT CHIP	0	Q307	8-729-027-31	TRANSISTOR DTA124EKA-T146	
JR381	1-216-864-11	SHORT CHIP	0	Q308	8-729-027-43	TRANSISTOR DTC114EKA-T146	
JR405	1-216-864-11	SHORT CHIP	0	Q486	8-729-027-43	TRANSISTOR DTC114EKA-T146	
JR406	1-216-864-11	SHORT CHIP	0	Q584	8-729-027-43	TRANSISTOR DTC114EKA-T146	
JR407	1-216-864-11	SHORT CHIP	0	< RESISTOR >			
JR408	1-216-864-11	SHORT CHIP	0	R101	1-216-812-11	METAL CHIP 180 5%	1/10W
JR419	1-216-864-11	SHORT CHIP	0	R102	1-216-825-11	METAL CHIP 2.2K 5%	1/10W
JR467	1-216-864-11	SHORT CHIP	0	R103	1-216-833-11	METAL CHIP 10K 5%	1/10W
JR480	1-216-864-11	SHORT CHIP	0	R104	1-216-841-11	METAL CHIP 47K 5%	1/10W
JR481	1-216-864-11	SHORT CHIP	0	R105	1-216-841-11	METAL CHIP 47K 5%	1/10W
JR487	1-216-864-11	SHORT CHIP	0	R106	1-216-830-11	METAL CHIP 5.6K 5%	1/10W
JR555	1-216-864-11	SHORT CHIP	0	R107	1-216-829-11	METAL CHIP 4.7K 5%	1/10W
		< COIL >		R108	1-216-825-11	METAL CHIP 2.2K 5%	1/10W
L103	1-410-780-11	INDUCTOR 27mH		R110	1-216-851-11	METAL CHIP 330K 5%	1/10W
L104	1-410-780-11	INDUCTOR 27mH		R111	1-216-821-11	METAL CHIP 1K 5%	1/10W
L105	1-414-189-31	INDUCTOR 100uH		R112	1-216-833-11	METAL CHIP 10K 5%	1/10W
L505	1-412-064-11	INDUCTOR 100uH		R113	1-216-833-11	METAL CHIP 10K 5%	1/10W
		< TRANSISTOR >		R114	1-216-864-11	SHORT CHIP 0	
Q101	8-729-901-81	TRANSISTOR 2SC2412K-T-146-R		R115	1-216-833-11	METAL CHIP 10K 5%	1/10W
Q103	8-729-802-80	TRANSISTOR 2SC3661		R116	1-216-833-11	METAL CHIP 10K 5%	1/10W
Q104	8-729-802-80	TRANSISTOR 2SC3661		R117	1-216-825-11	METAL CHIP 2.2K 5%	1/10W
Q105	8-729-802-80	TRANSISTOR 2SC3661		R118	1-216-835-11	METAL CHIP 15K 5%	1/10W
Q106	8-729-802-80	TRANSISTOR 2SC3661		R119	1-216-817-11	METAL CHIP 470 5%	1/10W
Q107	8-729-216-22	TRANSISTOR 2SA1162-G		R120	1-216-829-11	METAL CHIP 4.7K 5%	1/10W
Q108	8-729-027-43	TRANSISTOR DTC114EKA-T146		R121	1-216-827-11	METAL CHIP 3.3K 5%	1/10W
Q109	8-729-027-43	TRANSISTOR DTC114EKA-T146		R122	1-216-825-11	METAL CHIP 2.2K 5%	1/10W
Q110	8-729-027-23	TRANSISTOR DTA114EKA-T146		R123	1-216-825-11	METAL CHIP 2.2K 5%	1/10W
Q111	8-729-027-43	TRANSISTOR DTC114EKA-T146		R124	1-216-825-11	METAL CHIP 2.2K 5%	1/10W
Q112	8-729-141-75	TRANSISTOR 2SD596DV345		R125	1-216-838-11	METAL CHIP 27K 5%	1/10W
Q113	6-550-185-01	TRANSISTOR RT1P137P-TP-1		R126	1-216-829-11	METAL CHIP 4.7K 5%	1/10W
Q114	8-729-027-43	TRANSISTOR DTC114EKA-T146		R127	1-216-830-11	METAL CHIP 5.6K 5%	1/10W
Q118	8-729-903-46	TRANSISTOR 2SB1132-P		R128	1-216-837-11	METAL CHIP 22K 5%	1/10W
Q119	8-729-027-43	TRANSISTOR DTC114EKA-T146		R129	1-216-829-11	METAL CHIP 4.7K 5%	1/10W
Q120	8-729-903-46	TRANSISTOR 2SB1132-P		R130	1-216-841-11	METAL CHIP 47K 5%	1/10W
Q121	8-729-027-43	TRANSISTOR DTC114EKA-T146		R131	1-216-827-11	METAL CHIP 3.3K 5%	1/10W
				R133	1-216-857-11	METAL CHIP 1M 5%	1/10W

Ref. No.	Part No.	Description			Remark	Ref. No.	Part No.	Description			Remark
R136	1-216-833-11	METAL CHIP	10K	5%	1/10W	R200	1-216-841-11	METAL CHIP	47K	5%	1/10W
R138	1-216-841-11	METAL CHIP	47K	5%	1/10W	R202	1-216-809-11	METAL CHIP	100	5%	1/10W
R139	1-216-864-11	SHORT CHIP	0			R203	1-216-809-11	METAL CHIP	100	5%	1/10W
R140	1-216-833-11	METAL CHIP	10K	5%	1/10W	R204	1-216-809-11	METAL CHIP	100	5%	1/10W
R141	1-216-833-11	METAL CHIP	10K	5%	1/10W	R205	1-216-809-11	METAL CHIP	100	5%	1/10W
R142	1-216-833-11	METAL CHIP	10K	5%	1/10W	R207	1-216-809-11	METAL CHIP	100	5%	1/10W
R143	1-216-827-11	METAL CHIP	3.3K	5%	1/10W	R209	1-216-809-11	METAL CHIP	100	5%	1/10W
R144	1-216-805-11	METAL CHIP	47	5%	1/10W	R210	1-216-809-11	METAL CHIP	100	5%	1/10W
R145	1-216-833-11	METAL CHIP	10K	5%	1/10W	R212	1-216-809-11	METAL CHIP	100	5%	1/10W
R146	1-216-797-11	METAL CHIP	10	5%	1/10W	R214	1-216-864-11	SHORT CHIP	0		
R147	1-216-803-11	METAL CHIP	33	5%	1/10W	R215	1-216-821-11	METAL CHIP	1K	5%	1/10W
R148	1-216-841-11	METAL CHIP	47K	5%	1/10W	R216	1-216-813-11	METAL CHIP	220	5%	1/10W
R149	1-216-829-11	METAL CHIP	4.7K	5%	1/10W	R220	1-216-809-11	METAL CHIP	100	5%	1/10W
R150	1-216-841-11	METAL CHIP	47K	5%	1/10W	R221	1-216-809-11	METAL CHIP	100	5%	1/10W
R151	1-216-812-11	METAL CHIP	180	5%	1/10W	R222	1-216-809-11	METAL CHIP	100	5%	1/10W
R152	1-216-825-11	METAL CHIP	2.2K	5%	1/10W	R224	1-216-809-11	METAL CHIP	100	5%	1/10W
R153	1-216-833-11	METAL CHIP	10K	5%	1/10W	R225	1-216-839-11	METAL CHIP	33K	5%	1/10W
R154	1-216-823-11	METAL CHIP	1.5K	5%	1/10W	R226	1-216-809-11	METAL CHIP	100	5%	1/10W
R155	1-216-841-11	METAL CHIP	47K	5%	1/10W	R227	1-216-864-11	SHORT CHIP	0		
R156	1-216-830-11	METAL CHIP	5.6K	5%	1/10W	R230	1-216-809-11	METAL CHIP	100	5%	1/10W
R158	1-216-825-11	METAL CHIP	2.2K	5%	1/10W	R231	1-216-841-11	METAL CHIP	47K	5%	1/10W
R159	1-469-125-21	FERRITE, EMI (SMD) (1608)				R244	1-216-821-11	METAL CHIP	1K	5%	1/10W
R160	1-216-851-11	METAL CHIP	330K	5%	1/10W	R245	1-216-841-11	METAL CHIP	47K	5%	1/10W
R161	1-216-821-11	METAL CHIP	1K	5%	1/10W	R246	1-216-833-11	METAL CHIP	10K	5%	1/10W
R162	1-216-833-11	METAL CHIP	10K	5%	1/10W	R248	1-216-821-11	METAL CHIP	1K	5%	1/10W
R163	1-216-833-11	METAL CHIP	10K	5%	1/10W	R249	1-216-841-11	METAL CHIP	47K	5%	1/10W
R164	1-216-864-11	SHORT CHIP	0			R250	1-216-833-11	METAL CHIP	10K	5%	1/10W
R165	1-469-125-21	FERRITE, EMI (SMD) (1608)				R294	1-216-821-11	METAL CHIP	1K	5%	1/10W
R166	1-216-833-11	METAL CHIP	10K	5%	1/10W	R295	1-216-841-11	METAL CHIP	47K	5%	1/10W
R167	1-216-825-11	METAL CHIP	2.2K	5%	1/10W	R296	1-216-833-11	METAL CHIP	10K	5%	1/10W
R168	1-216-835-11	METAL CHIP	15K	5%	1/10W	R298	1-216-821-11	METAL CHIP	1K	5%	1/10W
R169	1-216-817-11	METAL CHIP	470	5%	1/10W	R299	1-216-841-11	METAL CHIP	47K	5%	1/10W
R172	1-216-825-11	METAL CHIP	2.2K	5%	1/10W	R300	1-216-833-11	METAL CHIP	10K	5%	1/10W
R173	1-216-825-11	METAL CHIP	2.2K	5%	1/10W	R301	1-216-833-11	METAL CHIP	10K	5%	1/10W
R174	1-216-825-11	METAL CHIP	2.2K	5%	1/10W	R302	1-216-837-11	METAL CHIP	22K	5%	1/10W
R175	1-216-838-11	METAL CHIP	27K	5%	1/10W	R303	1-216-845-11	METAL CHIP	100K	5%	1/10W
R176	1-216-829-11	METAL CHIP	4.7K	5%	1/10W	R304	1-216-835-11	METAL CHIP	15K	5%	1/10W
R177	1-216-830-11	METAL CHIP	5.6K	5%	1/10W	R305	1-216-843-11	METAL CHIP	68K	5%	1/10W
R178	1-216-819-11	METAL CHIP	680	5%	1/10W	R308	1-216-853-11	METAL CHIP	470K	5%	1/10W
R179	1-216-825-11	METAL CHIP	2.2K	5%	1/10W	R309	1-216-833-11	METAL CHIP	10K	5%	1/10W
R180	1-216-825-11	METAL CHIP	2.2K	5%	1/10W	R310	1-216-835-11	METAL CHIP	15K	5%	1/10W
R181	1-216-819-11	METAL CHIP	680	5%	1/10W	R311	1-216-843-11	METAL CHIP	68K	5%	1/10W
R182	1-216-827-11	METAL CHIP	3.3K	5%	1/10W	R312	1-216-853-11	METAL CHIP	470K	5%	1/10W
R183	1-216-827-11	METAL CHIP	3.3K	5%	1/10W	R323	1-216-833-11	METAL CHIP	10K	5%	1/10W
R184	1-216-827-11	METAL CHIP	3.3K	5%	1/10W	R329	1-216-833-11	METAL CHIP	10K	5%	1/10W
R186	1-216-825-11	METAL CHIP	2.2K	5%	1/10W	R330	1-216-833-11	METAL CHIP	10K	5%	1/10W
R188	1-216-841-11	METAL CHIP	47K	5%	1/10W	R337	1-216-833-11	METAL CHIP	10K	5%	1/10W
R189	1-216-864-11	SHORT CHIP	0			R338	1-216-833-11	METAL CHIP	10K	5%	1/10W
R190	1-216-833-11	METAL CHIP	10K	5%	1/10W	R340	1-216-833-11	METAL CHIP	10K	5%	1/10W
R191	1-216-817-11	METAL CHIP	470	5%	1/10W	R341	1-216-833-11	METAL CHIP	10K	5%	1/10W
R192	1-216-817-11	METAL CHIP	470	5%	1/10W	R354	1-216-833-11	METAL CHIP	10K	5%	1/10W
R193	1-216-829-11	METAL CHIP	4.7K	5%	1/10W	R355	1-216-833-11	METAL CHIP	10K	5%	1/10W
R194	1-216-829-11	METAL CHIP	4.7K	5%	1/10W	R372	1-216-833-11	METAL CHIP	10K	5%	1/10W
R195	1-216-857-11	METAL CHIP	1M	5%	1/10W	R373	1-216-833-11	METAL CHIP	10K	5%	1/10W
R196	1-216-825-11	METAL CHIP	2.2K	5%	1/10W	R374	1-216-833-11	METAL CHIP	10K	5%	1/10W
R197	1-216-819-11	METAL CHIP	680	5%	1/10W	R381	1-216-864-11	SHORT CHIP	0		
R198	1-469-125-21	FERRITE, EMI (SMD) (1608)				R385	1-216-833-11	METAL CHIP	10K	5%	1/10W
R199	1-469-125-21	FERRITE, EMI (SMD) (1608)				R392	1-216-864-11	SHORT CHIP	0		

HCD-GNZ55D

MAIN **MIC**

Ref. No.	Part No.	Description	Remark
R393	1-216-811-11	METAL CHIP	150 5% 1/10W (E13)
R393	1-216-829-11	METAL CHIP	4.7K 5% 1/10W (E3,E12,E15,EA)
R394	1-216-827-11	METAL CHIP	3.3K 5% 1/10W
R395	1-216-827-11	METAL CHIP	3.3K 5% 1/10W
R397	1-216-827-11	METAL CHIP	3.3K 5% 1/10W
R401	1-216-809-11	METAL CHIP	100 5% 1/10W
R402	1-216-809-11	METAL CHIP	100 5% 1/10W
R404	1-216-809-11	METAL CHIP	100 5% 1/10W
R411	1-216-851-11	METAL CHIP	330K 5% 1/10W
R412	1-216-845-11	METAL CHIP	100K 5% 1/10W
R413	1-216-864-11	SHORT CHIP	0
R417	1-216-833-11	METAL CHIP	10K 5% 1/10W
R420	1-216-821-11	METAL CHIP	1K 5% 1/10W
R421	1-216-809-11	METAL CHIP	100 5% 1/10W
R422	1-216-809-11	METAL CHIP	100 5% 1/10W
R423	1-216-809-11	METAL CHIP	100 5% 1/10W
R424	1-216-809-11	METAL CHIP	100 5% 1/10W
R425	1-216-809-11	METAL CHIP	100 5% 1/10W
R426	1-216-809-11	METAL CHIP	100 5% 1/10W
R427	1-216-809-11	METAL CHIP	100 5% 1/10W
R428	1-216-809-11	METAL CHIP	100 5% 1/10W
R429	1-216-809-11	METAL CHIP	100 5% 1/10W
R430	1-216-809-11	METAL CHIP	100 5% 1/10W
R431	1-216-809-11	METAL CHIP	100 5% 1/10W
R432	1-216-809-11	METAL CHIP	100 5% 1/10W
R433	1-216-809-11	METAL CHIP	100 5% 1/10W
R435	1-216-809-11	METAL CHIP	100 5% 1/10W
R436	1-216-809-11	METAL CHIP	100 5% 1/10W
R437	1-216-809-11	METAL CHIP	100 5% 1/10W
R438	1-216-809-11	METAL CHIP	100 5% 1/10W
R439	1-216-809-11	METAL CHIP	100 5% 1/10W
R440	1-216-809-11	METAL CHIP	100 5% 1/10W
R441	1-216-809-11	METAL CHIP	100 5% 1/10W
R442	1-216-809-11	METAL CHIP	100 5% 1/10W
R443	1-216-809-11	METAL CHIP	100 5% 1/10W
R444	1-216-809-11	METAL CHIP	100 5% 1/10W
R445	1-216-809-11	METAL CHIP	100 5% 1/10W
R446	1-216-809-11	METAL CHIP	100 5% 1/10W
R447	1-216-809-11	METAL CHIP	100 5% 1/10W
R448	1-216-809-11	METAL CHIP	100 5% 1/10W
R449	1-216-809-11	METAL CHIP	100 5% 1/10W
R450	1-216-809-11	METAL CHIP	100 5% 1/10W
R451	1-216-809-11	METAL CHIP	100 5% 1/10W
R452	1-216-809-11	METAL CHIP	100 5% 1/10W
R453	1-216-809-11	METAL CHIP	100 5% 1/10W
R454	1-216-809-11	METAL CHIP	100 5% 1/10W
R455	1-216-809-11	METAL CHIP	100 5% 1/10W
R456	1-216-812-11	METAL CHIP	180 5% 1/10W
R457	1-216-809-11	METAL CHIP	100 5% 1/10W
R458	1-216-809-11	METAL CHIP	100 5% 1/10W
R459	1-216-809-11	METAL CHIP	100 5% 1/10W
R460	1-216-809-11	METAL CHIP	100 5% 1/10W
R463	1-216-809-11	METAL CHIP	100 5% 1/10W
R465	1-216-809-11	METAL CHIP	100 5% 1/10W
R472	1-216-809-11	METAL CHIP	100 5% 1/10W
R473	1-216-809-11	METAL CHIP	100 5% 1/10W

Ref. No.	Part No.	Description	Remark
R474	1-216-809-11	METAL CHIP	100 5% 1/10W
R476	1-216-809-11	METAL CHIP	100 5% 1/10W
R477	1-216-809-11	METAL CHIP	100 5% 1/10W
R478	1-216-809-11	METAL CHIP	100 5% 1/10W
R479	1-216-809-11	METAL CHIP	100 5% 1/10W
R483	1-216-809-11	METAL CHIP	100 5% 1/10W
R484	1-216-809-11	METAL CHIP	100 5% 1/10W
R485	1-216-809-11	METAL CHIP	100 5% 1/10W
R486	1-216-825-11	METAL CHIP	2.2K 5% 1/10W
R488	1-216-825-11	METAL CHIP	2.2K 5% 1/10W
R489	1-216-809-11	METAL CHIP	100 5% 1/10W
R490	1-216-809-11	METAL CHIP	100 5% 1/10W
R491	1-216-809-11	METAL CHIP	100 5% 1/10W
R493	1-216-815-11	METAL CHIP	330 5% 1/10W (E3,E15)
R493	1-216-819-11	METAL CHIP	680 5% 1/10W (E12)
R493	1-216-827-11	METAL CHIP	3.3K 5% 1/10W (EA)
R493	1-216-829-11	METAL CHIP	4.7K 5% 1/10W (E13)
R493	1-216-864-11	SHORT CHIP	0 (MY,SP,PH,TH)
R494	1-216-813-11	METAL CHIP	220 5% 1/10W
R495	1-216-813-11	METAL CHIP	220 5% 1/10W
R497	1-216-813-11	METAL CHIP	220 5% 1/10W
R500	1-216-809-11	METAL CHIP	100 5% 1/10W
△R506	1-219-153-11	FUSIBLE	10 5% 1/4W F
R508	1-216-830-11	METAL CHIP	5.6K 5% 1/10W
R509	1-216-827-11	METAL CHIP	3.3K 5% 1/10W
R532	1-216-864-11	SHORT CHIP	0
R582	1-216-864-11	SHORT CHIP	0
R584	1-216-830-11	METAL CHIP	5.6K 5% 1/10W
R585	1-216-841-11	METAL CHIP	47K 5% 1/10W
R586	1-216-830-11	METAL CHIP	5.6K 5% 1/10W
R587	1-216-841-11	METAL CHIP	47K 5% 1/10W
R590	1-216-833-11	METAL CHIP	10K 5% 1/10W
R591	1-216-833-11	METAL CHIP	10K 5% 1/10W
R592	1-216-845-11	METAL CHIP	100K 5% 1/10W
R593	1-216-845-11	METAL CHIP	100K 5% 1/10W
< TRANSFORMER >			
T101	1-433-372-11	TRANSFORMER, BIAS OSCILLATION	
< VIBRATOR >			
X401	1-760-252-12	VIBRATOR, CRYSTAL (32.768kHz)	
X402	1-795-058-21	VIBRATOR, CERAMIC (5MHz)	

A-1167-725-A		MIC BOARD, COMPLETE	

< CAPACITOR >			
C1401	1-100-597-11	CERAMIC CHIP	0.1uF 10% 25V
C1411	1-162-970-11	CERAMIC CHIP	0.01uF 10% 25V
C1415	1-100-597-11	CERAMIC CHIP	0.1uF 10% 25V
C1416	1-124-257-00	ELECT	2.2uF 20% 50V
C1417	1-162-964-11	CERAMIC CHIP	0.001uF 10% 50V
C1418	1-162-963-11	CERAMIC CHIP	680PF 10% 50V
C1424	1-100-597-11	CERAMIC CHIP	0.1uF 10% 25V

MIC **MOTOR (LD)** **MOTOR (TB)** **PANEL**

Ref. No.	Part No.	Description	Remark
C1428	1-162-923-11	CERAMIC CHIP 47PF 5%	50V
C1429	1-124-257-00	ELECT 2.2uF 20%	50V
C1430	1-126-160-11	ELECT 1uF 20%	50V
C1433	1-162-923-11	CERAMIC CHIP 47PF 5%	50V
C1434	1-124-261-00	ELECT 10uF 20%	50V
C1435	1-126-176-11	ELECT 220uF 20%	10V
C1436	1-162-968-11	CERAMIC CHIP 0.0047uF 10%	50V
C1437	1-162-970-11	CERAMIC CHIP 0.01uF 10%	25V
C1468	1-164-217-11	CERAMIC CHIP 150PF 5%	50V
C1478	1-162-923-11	CERAMIC CHIP 47PF 5%	50V
C1479	1-124-464-11	ELECT 0.22uF 20%	50V
C1480	1-124-257-00	ELECT 2.2uF 20%	50V
C1486	1-162-968-11	CERAMIC CHIP 0.0047uF 10%	50V
C1487	1-162-970-11	CERAMIC CHIP 0.01uF 10%	25V
< IC >			
IC1401	8-759-710-97	IC NJM4565M-D	
< JACK >			
J1400	1-817-630-11	JACK (LARGE TYPE) (MIC)	
J1401	1-794-702-11	JACK, HEADPHONE (PHONES)	
< JUMPER RESISTOR >			
JR1401	1-216-864-11	SHORT CHIP 0	
JR1403	1-216-296-11	SHORT CHIP 0	
JR1433	1-216-864-11	SHORT CHIP 0	
JR1483	1-216-864-11	SHORT CHIP 0	
< TRANSISTOR >			
Q1400	8-729-802-80	TRANSISTOR 2SC3661	
Q1401	8-729-802-80	TRANSISTOR 2SC3661	
Q1450	8-729-802-80	TRANSISTOR 2SC3661	
Q1451	8-729-802-80	TRANSISTOR 2SC3661	
< RESISTOR >			
R1411	1-216-833-11	METAL CHIP 10K 5%	1/10W
R1417	1-216-864-11	SHORT CHIP 0	
R1422	1-216-864-11	SHORT CHIP 0	
R1424	1-216-821-11	METAL CHIP 1K 5%	1/10W
R1425	1-216-845-11	METAL CHIP 100K 5%	1/10W
R1426	1-216-839-11	METAL CHIP 33K 5%	1/10W
R1427	1-216-821-11	METAL CHIP 1K 5%	1/10W
R1428	1-216-809-11	METAL CHIP 100 5%	1/10W
R1430	1-216-864-11	SHORT CHIP 0	
R1431	1-216-864-11	SHORT CHIP 0	
R1432	1-216-797-11	METAL CHIP 10 5%	1/10W
R1433	1-216-797-11	METAL CHIP 10 5%	1/10W
R1434	1-216-797-11	METAL CHIP 10 5%	1/10W
R1435	1-216-797-11	METAL CHIP 10 5%	1/10W
R1436	1-216-829-11	METAL CHIP 4.7K 5%	1/10W
R1437	1-216-845-11	METAL CHIP 100K 5%	1/10W
R1439	1-216-825-11	METAL CHIP 2.2K 5%	1/10W
R1440	1-216-825-11	METAL CHIP 2.2K 5%	1/10W
R1441	1-216-809-11	METAL CHIP 100 5%	1/10W
R1442	1-216-821-11	METAL CHIP 1K 5%	1/10W
R1443	1-216-821-11	METAL CHIP 1K 5%	1/10W
R1476	1-216-847-11	METAL CHIP 150K 5%	1/10W
R1477	1-216-833-11	METAL CHIP 10K 5%	1/10W

Ref. No.	Part No.	Description	Remark
R1482	1-216-797-11	METAL CHIP 10 5%	1/10W
R1483	1-216-797-11	METAL CHIP 10 5%	1/10W
R1484	1-216-797-11	METAL CHIP 10 5%	1/10W
R1485	1-216-797-11	METAL CHIP 10 5%	1/10W
R1486	1-216-829-11	METAL CHIP 4.7K 5%	1/10W
R1492	1-216-821-11	METAL CHIP 1K 5%	1/10W
R1493	1-216-821-11	METAL CHIP 1K 5%	1/10W
< VARIABLE RESISTOR >			
RV1400	1-223-983-11	RES, VAR, CARBON 50K (MIC LEVEL)	

1-687-133-12 MOTOR (LD) BOARD			

1-687-134-12 MOTOR (TB) BOARD			

< CONNECTOR >			
CN742	1-784-727-11	CONNECTOR, FFC 5P	

A-1167-723-A PANEL BOARD, COMPLETE			

< CAPACITOR >			
C1300	1-128-131-11	ELECT 22uF 20%	50V
C1301	1-162-995-11	CERAMIC CHIP 0.022uF	50V
C1302	1-162-974-11	CERAMIC CHIP 0.01uF	50V
C1304	1-126-969-11	ELECT 220uF 20%	50V
C1305	1-124-261-00	ELECT 10uF 20%	50V
C1306	1-162-974-11	CERAMIC CHIP 0.01uF	50V
C1307	1-107-826-11	CERAMIC CHIP 0.1uF 10%	16V
C1309	1-124-589-11	ELECT 47uF 20%	16V
C1310	1-162-927-11	CERAMIC CHIP 100PF 5%	50V
C1311	1-126-157-11	ELECT 10uF 20%	16V
C1312	1-115-416-11	CERAMIC CHIP 0.001uF 5%	25V
C1313	1-115-416-11	CERAMIC CHIP 0.001uF 5%	25V
C1314	1-115-416-11	CERAMIC CHIP 0.001uF 5%	25V
C1315	1-115-416-11	CERAMIC CHIP 0.001uF 5%	25V
C1316	1-162-927-11	CERAMIC CHIP 100PF 5%	50V
C1317	1-162-927-11	CERAMIC CHIP 100PF 5%	50V
C1318	1-162-927-11	CERAMIC CHIP 100PF 5%	50V
C1319	1-162-927-11	CERAMIC CHIP 100PF 5%	50V
C1320	1-162-927-11	CERAMIC CHIP 100PF 5%	50V
C1321	1-162-927-11	CERAMIC CHIP 100PF 5%	50V
C1322	1-162-927-11	CERAMIC CHIP 100PF 5%	50V
C1323	1-162-927-11	CERAMIC CHIP 100PF 5%	50V
C1324	1-162-927-11	CERAMIC CHIP 100PF 5%	50V
C1325	1-162-927-11	CERAMIC CHIP 100PF 5%	50V
C1326	1-162-927-11	CERAMIC CHIP 100PF 5%	50V
C1327	1-162-927-11	CERAMIC CHIP 100PF 5%	50V
C1328	1-162-927-11	CERAMIC CHIP 100PF 5%	50V
C1329	1-162-927-11	CERAMIC CHIP 100PF 5%	50V
C1330	1-162-927-11	CERAMIC CHIP 100PF 5%	50V
C1331	1-162-927-11	CERAMIC CHIP 100PF 5%	50V
C1357	1-107-826-11	CERAMIC CHIP 0.1uF 10%	16V

HCD-GNZ55D

PANEL **SENSOR**

Ref. No.	Part No.	Description	Remark
< CONNECTOR >			
CN1402	1-784-747-11	CONNECTOR, FFC 25P	
CN1452	1-785-336-11	PIN, CONNECTOR (LIGHT ANGLE) 10P	
CN1453	1-818-282-11	PIN, CONNECTOR (PWB) 3P	
< DIODE >			
D1300	6-501-193-01	DIODE 1SS355WTE-17	
D1301	6-501-193-01	DIODE 1SS355WTE-17	
D1302	6-501-193-01	DIODE 1SS355WTE-17	
D1303	6-501-193-01	DIODE 1SS355WTE-17	
D1304	6-500-809-01	LED SELU5223C-STP15 (STANDBY)	
D1305	8-719-059-18	DIODE RD6.2FM-T1	
D1306	6-501-193-01	DIODE 1SS355WTE-17	
D1314	6-501-193-01	DIODE 1SS355WTE-17	
< VACUUM FLUORESCENT DISPLAY >			
FL1300	1-519-859-11	VACUUM FLUORESCENT DISPLAY	
< IC >			
IC1300	6-709-115-11	IC NJU3427FA2	
< JUMPER RESISTOR >			
JR1305	1-216-864-11	SHORT CHIP 0	
< COIL >			
L1300	1-410-671-31	INDUCTOR 47uH	
< TRANSISTOR >			
Q1300	6-550-065-01	FET CPH5504-TL-E	
Q1305	8-729-027-50	TRANSISTOR DTC123JKA-T146	
Q1307	8-729-027-50	TRANSISTOR DTC123JKA-T146	
Q1311	8-729-027-56	TRANSISTOR DTC143TKA-T146	
Q1312	8-729-027-56	TRANSISTOR DTC143TKA-T146	
Q1313	8-729-027-56	TRANSISTOR DTC143TKA-T146	
Q1314	8-729-027-56	TRANSISTOR DTC143TKA-T146	
Q1315	8-729-027-56	TRANSISTOR DTC143TKA-T146	
Q1316	8-729-027-56	TRANSISTOR DTC143TKA-T146	
< RESISTOR >			
R1300	1-216-827-11	METAL CHIP 3.3K 5% 1/10W	
R1301	1-216-837-11	METAL CHIP 22K 5% 1/10W	
R1302	1-216-837-11	METAL CHIP 22K 5% 1/10W	
R1303	1-216-809-11	METAL CHIP 100 5% 1/10W	
R1304	1-216-809-11	METAL CHIP 100 5% 1/10W	
△R1305	1-215-871-11	METAL OXIDE 2.2K 5% 1W F	
R1307	1-216-829-11	METAL CHIP 4.7K 5% 1/10W	
R1308	1-216-821-11	METAL CHIP 1K 5% 1/10W	
R1314	1-216-864-11	SHORT CHIP 0	
R1318	1-216-829-11	METAL CHIP 4.7K 5% 1/10W	
R1319	1-216-825-11	METAL CHIP 2.2K 5% 1/10W	
R1320	1-216-823-11	METAL CHIP 1.5K 5% 1/10W	
R1321	1-216-821-11	METAL CHIP 1K 5% 1/10W	
R1322	1-216-819-11	METAL CHIP 680 5% 1/10W	
R1323	1-216-817-11	METAL CHIP 470 5% 1/10W	
R1324	1-216-815-11	METAL CHIP 330 5% 1/10W	
R1325	1-216-815-11	METAL CHIP 330 5% 1/10W	

Ref. No.	Part No.	Description	Remark
R1326	1-216-817-11	METAL CHIP 470 5% 1/10W	
R1327	1-216-819-11	METAL CHIP 680 5% 1/10W	
R1328	1-216-821-11	METAL CHIP 1K 5% 1/10W	
R1330	1-216-815-11	METAL CHIP 330 5% 1/10W	
R1331	1-216-817-11	METAL CHIP 470 5% 1/10W	
R1332	1-216-819-11	METAL CHIP 680 5% 1/10W	
R1344	1-216-864-11	SHORT CHIP 0	
R1351	1-216-809-11	METAL CHIP 100 5% 1/10W	
R1352	1-216-809-11	METAL CHIP 100 5% 1/10W	
R1353	1-216-809-11	METAL CHIP 100 5% 1/10W	
R1355	1-216-809-11	METAL CHIP 100 5% 1/10W	
R1356	1-216-829-11	METAL CHIP 4.7K 5% 1/10W	
R1357	1-216-829-11	METAL CHIP 4.7K 5% 1/10W	
R1358	1-216-829-11	METAL CHIP 4.7K 5% 1/10W	
R1359	1-216-829-11	METAL CHIP 4.7K 5% 1/10W	
R1360	1-216-829-11	METAL CHIP 4.7K 5% 1/10W	
R1361	1-216-829-11	METAL CHIP 4.7K 5% 1/10W	
< SWITCH >			
S1300	1-762-875-21	SWITCH, KEYBOARD (DISPLAY)	
S1301	1-762-875-21	SWITCH, KEYBOARD (I/⏏)	
S1309	1-762-875-21	SWITCH, KEYBOARD (TAPE A/B)	
S1310	1-762-875-21	SWITCH, KEYBOARD (■)	
S1311	1-762-875-21	SWITCH, KEYBOARD (◀▶)	
S1312	1-762-875-21	SWITCH, KEYBOARD (DISC SKIP/EX-CHANGE)	
S1313	1-762-875-21	SWITCH, KEYBOARD (DISC 3)	
S1314	1-762-875-21	SWITCH, KEYBOARD (DISC 2)	
S1315	1-762-875-21	SWITCH, KEYBOARD (DISC 1)	
S1316	1-762-875-21	SWITCH, KEYBOARD (▲ OPEN/CLOSE)	
S1317	1-762-875-21	SWITCH, KEYBOARD (■)	
S1320	1-762-875-21	SWITCH, KEYBOARD (DIRECTION)	
S1321	1-762-875-21	SWITCH, KEYBOARD (ILLUMINATION)	
S1322	1-762-875-21	SWITCH, KEYBOARD (TUNER/BAND)	
S1323	1-762-875-21	SWITCH, KEYBOARD (DVD)	
S1324	1-762-875-21	SWITCH, KEYBOARD (CD SYNC)	
S1325	1-762-875-21	SWITCH, KEYBOARD (TUNING - ◀◀ ◀▶)	
S1326	1-762-875-21	SWITCH, KEYBOARD (TUNING + ▶▶ ▶▶)	
S1327	1-762-875-21	SWITCH, KEYBOARD (REC PAUSE/START)	
< TRANSFORMER >			
T1300	1-443-894-11	TRANSFORMER, DC/DC CONVERTER	

	1-687-132-12	SENSOR BOARD	

< CONNECTOR >			
CN731	1-785-329-21	PIN, CONNECTOR (LIGHT ANGLE) 3P	
< IC >			
IC731	6-600-022-01	IC RPI-576	

Ref. No.	Part No.	Description	Remark	Ref. No.	Part No.	Description	Remark
		SPEAKER BOARD *****		C647	1-115-339-11	CERAMIC CHIP 0.1uF 10%	50V
		< CAPACITOR >		C648	1-126-947-11	ELECT 47uF 20%	35V
C1502	1-162-964-11	CERAMIC CHIP 0.001uF 10%	50V	C649	1-126-947-11	ELECT 47uF 20%	35V
C1512	1-162-964-11	CERAMIC CHIP 0.001uF 10%	50V	C650	1-115-339-11	CERAMIC CHIP 0.1uF 10%	50V
C1522	1-162-964-11	CERAMIC CHIP 0.001uF 10%	50V	C651	1-162-961-11	CERAMIC CHIP 330PF 10%	50V
C1532	1-162-964-11	CERAMIC CHIP 0.001uF 10%	50V				
		< CONNECTOR >		C652	1-163-078-11	CERAMIC CHIP 0.033uF 10%	25V
CN1501	1-564-507-11	PLUG, CONNECTOR 4P		C653	1-127-573-11	CERAMIC CHIP 1uF 10%	16V
		< EARTH TERMINAL >		C654	1-115-339-11	CERAMIC CHIP 0.1uF 10%	50V
* EP1500	1-537-738-21	TERMINAL, EARTH		C655	1-126-953-11	ELECT 2200uF 20%	35V
* EP1501	1-537-738-21	TERMINAL, EARTH		C656	1-115-339-11	CERAMIC CHIP 0.1uF 10%	50V
		< TERMINAL BOARD >					
TM1500	1-820-067-11	TERMINAL BOARD (SPEAKER) (FRONT SPEAKER)		C657	1-126-953-11	ELECT 2200uF 20%	35V
*****				C680	1-136-177-00	FILM 1uF 5%	50V
	1-687-669-12	SW BOARD *****		C681	1-125-898-11	CERAMIC CHIP 0.22uF 10%	50V
		< SWITCH >		C682	1-162-966-11	CERAMIC CHIP 0.0022uF 10%	50V
S751	1-786-514-11	SWITCH, LEVER (SLIDE) (OPEN/CLOSE DETECT)		C683	1-162-966-11	CERAMIC CHIP 0.0022uF 10%	50V
*****				C684	1-136-177-00	FILM 1uF 5%	50V
A-1164-101-A		S-MASTER BOARD, COMPLETE *****		C685	1-125-898-11	CERAMIC CHIP 0.22uF 10%	50V
		< CAPACITOR >		C686	1-162-966-11	CERAMIC CHIP 0.0022uF 10%	50V
C604	1-107-826-11	CERAMIC CHIP 0.1uF 10%	16V	C687	1-162-966-11	CERAMIC CHIP 0.0022uF 10%	50V
C605	1-107-826-11	CERAMIC CHIP 0.1uF 10%	16V	C690	1-136-177-00	FILM 1uF 5%	50V
C606	1-107-826-11	CERAMIC CHIP 0.1uF 10%	16V				
C607	1-107-826-11	CERAMIC CHIP 0.1uF 10%	16V	C691	1-125-898-11	CERAMIC CHIP 0.22uF 10%	50V
C608	1-107-826-11	CERAMIC CHIP 0.1uF 10%	16V	C692	1-162-966-11	CERAMIC CHIP 0.0022uF 10%	50V
				C693	1-162-966-11	CERAMIC CHIP 0.0022uF 10%	50V
C609	1-104-658-11	ELECT 100uF 20%	10V	C694	1-136-177-00	FILM 1uF 5%	50V
C610	1-107-826-11	CERAMIC CHIP 0.1uF 10%	16V	C695	1-125-898-11	CERAMIC CHIP 0.22uF 10%	50V
C611	1-107-826-11	CERAMIC CHIP 0.1uF 10%	16V				
C612	1-107-826-11	CERAMIC CHIP 0.1uF 10%	16V	C696	1-162-966-11	CERAMIC CHIP 0.0022uF 10%	50V
C613	1-107-826-11	CERAMIC CHIP 0.1uF 10%	16V	C697	1-162-966-11	CERAMIC CHIP 0.0022uF 10%	50V
				C800	1-124-248-00	ELECT 22uF 20%	25V
C631	1-127-573-11	CERAMIC CHIP 1uF 10%	16V	C801	1-162-970-11	CERAMIC CHIP 0.01uF 10%	25V
C632	1-107-826-11	CERAMIC CHIP 0.1uF 10%	16V	C805	1-104-658-11	ELECT 100uF 20%	10V
C633	1-126-933-11	ELECT 100uF 20%	16V				
C634	1-107-826-11	CERAMIC CHIP 0.1uF 10%	16V	C806	1-162-970-11	CERAMIC CHIP 0.01uF 10%	25V
C635	1-127-573-11	CERAMIC CHIP 1uF 10%	16V	C809	1-162-970-11	CERAMIC CHIP 0.01uF 10%	25V
				C810	1-104-658-11	ELECT 100uF 20%	10V
C636	1-127-573-11	CERAMIC CHIP 1uF 10%	16V	C811	1-162-970-11	CERAMIC CHIP 0.01uF 10%	25V
C637	1-163-078-11	CERAMIC CHIP 0.033uF 10%	25V	C819	1-104-662-11	ELECT 22uF 20%	25V
C638	1-162-961-11	CERAMIC CHIP 330PF 10%	50V				
C639	1-115-339-11	CERAMIC CHIP 0.1uF 10%	50V	C821	1-162-910-11	CERAMIC CHIP 5PF 0.25PF	50V
C640	1-126-947-11	ELECT 47uF 20%	35V	C822	1-162-964-11	CERAMIC CHIP 0.001uF 10%	50V
				C823	1-162-915-11	CERAMIC CHIP 10PF 0.5PF	50V
C641	1-126-947-11	ELECT 47uF 20%	35V	C830	1-126-964-11	ELECT 10uF 20%	50V
C642	1-115-339-11	CERAMIC CHIP 0.1uF 10%	50V	C840	1-164-337-11	CERAMIC CHIP 2.2uF	16V
C643	1-162-961-11	CERAMIC CHIP 330PF 10%	50V				
C644	1-163-078-11	CERAMIC CHIP 0.033uF 10%	25V	C860	1-117-370-11	CERAMIC CHIP 10uF	10V
C645	1-163-078-11	CERAMIC CHIP 0.033uF 10%	25V	C865	1-117-370-11	CERAMIC CHIP 10uF	10V
				C871	1-216-864-11	SHORT CHIP 0	
C646	1-162-961-11	CERAMIC CHIP 330PF 10%	50V	C872	1-107-826-11	CERAMIC CHIP 0.1uF 10%	16V
				C874	1-107-826-11	CERAMIC CHIP 0.1uF 10%	16V
				C876	1-216-864-11	SHORT CHIP 0	
				C877	1-216-864-11	SHORT CHIP 0	
				C878	1-107-826-11	CERAMIC CHIP 0.1uF 10%	16V
				C879	1-216-864-11	SHORT CHIP 0	
				C880	1-162-927-11	CERAMIC CHIP 100PF 5%	50V
				C881	1-162-927-11	CERAMIC CHIP 100PF 5%	50V
				C882	1-162-927-11	CERAMIC CHIP 100PF 5%	50V
				C883	1-126-925-11	ELECT 470uF 20%	10V
				C884	1-162-927-11	CERAMIC CHIP 100PF 5%	50V
				C885	1-162-927-11	CERAMIC CHIP 100PF 5%	50V
				C886	1-126-935-11	ELECT 470uF 20%	16V
				C887	1-126-925-11	ELECT 470uF 20%	10V
				C888	1-119-774-11	ELECT 100uF 20%	16V

HCD-GNZ55D

S-MASTER

Ref. No.	Part No.	Description	Remark	Ref. No.	Part No.	Description	Remark
C889	1-107-826-11	CERAMIC CHIP 0.1uF 10%	16V	JR804	1-216-864-11	SHORT CHIP 0	
C890	1-119-774-11	ELECT 100uF 20%	16V			< COIL >	
C891	1-107-826-11	CERAMIC CHIP 0.1uF 10%	16V				
C892	1-162-927-11	CERAMIC CHIP 100PF 5%	50V				
		< CONNECTOR >					
CN500	1-784-776-11	CONNECTOR, FFC 15P		L680	1-457-235-11	COIL, CHOKE 10uH	
* CN501	1-564-710-11	PIN, CONNECTOR (SMALL TYPE) 8P		L681	1-457-235-11	COIL, CHOKE 10uH	
* CN502	1-564-243-11	PIN, CONNECTOR (3.96mm PITCH) 6P		L690	1-457-235-11	COIL, CHOKE 10uH	
CN503	1-564-705-11	PIN, CONNECTOR (SMALL TYPE) 3P		L691	1-457-235-11	COIL, CHOKE 10uH	
		< DIODE >		L800	1-216-295-11	SHORT CHIP 0	
D651	6-500-260-01	DIODE P6SMB39AT3					
D652	6-500-260-01	DIODE P6SMB39AT3		L802	1-216-295-11	SHORT CHIP 0	
D653	6-500-260-01	DIODE P6SMB39AT3		L804	1-412-939-11	INDUCTOR 1uH	
D654	6-500-260-01	DIODE P6SMB39AT3				< TRANSISTOR >	
D820	8-719-988-61	DIODE 1SS355TE-17		Q840	8-729-120-28	TRANSISTOR 2SC1623-L5L6	
D880	8-719-988-61	DIODE 1SS355TE-17		Q860	8-729-602-36	TRANSISTOR 2SA1602-F	
D881	8-719-988-61	DIODE 1SS355TE-17		Q861	8-729-602-36	TRANSISTOR 2SA1602-F	
D882	8-719-988-61	DIODE 1SS355TE-17		Q865	8-729-602-36	TRANSISTOR 2SA1602-F	
D883	8-719-988-61	DIODE 1SS355TE-17		Q866	8-729-602-36	TRANSISTOR 2SA1602-F	
D884	1-216-295-11	SHORT CHIP 0				< RESISTOR >	
D885	1-216-295-11	SHORT CHIP 0		R600	1-216-864-11	SHORT CHIP 0	
D888	1-216-295-11	SHORT CHIP 0		R601	1-216-864-11	SHORT CHIP 0	
D889	1-216-295-11	SHORT CHIP 0		R602	1-216-833-11	METAL CHIP 10K 5%	1/10W
D890	1-216-295-11	SHORT CHIP 0		R603	1-216-809-11	METAL CHIP 100 5%	1/10W
D891	1-216-295-11	SHORT CHIP 0		R605	1-216-817-11	METAL CHIP 470 5%	1/10W
D892	8-719-988-61	DIODE 1SS355TE-17		R606	1-216-817-11	METAL CHIP 470 5%	1/10W
D893	8-719-988-61	DIODE 1SS355TE-17		R607	1-216-817-11	METAL CHIP 470 5%	1/10W
D894	1-216-295-11	SHORT CHIP 0		R609	1-216-864-11	SHORT CHIP 0	
D895	1-216-295-11	SHORT CHIP 0		R611	1-216-864-11	SHORT CHIP 0	
		< GROUND TERMINAL >		R612	1-216-833-11	METAL CHIP 10K 5%	1/10W
EP880	1-537-738-21	TERMINAL, GROUND		R616	1-216-809-11	METAL CHIP 100 5%	1/10W
EP881	1-537-738-21	TERMINAL, GROUND		R617	1-216-809-11	METAL CHIP 100 5%	1/10W
EP882	1-537-738-21	TERMINAL, GROUND		R619	1-216-821-11	METAL CHIP 1K 5%	1/10W
EP884	1-537-738-21	TERMINAL, GROUND		R620	1-216-821-11	METAL CHIP 1K 5%	1/10W
EP885	1-537-738-21	TERMINAL, GROUND		R621	1-216-821-11	METAL CHIP 1K 5%	1/10W
EP886	1-537-738-21	TERMINAL, GROUND		R631	1-216-791-11	METAL CHIP 3.3 5%	1/10W
		< JUMPER RESISTOR >		R632	1-216-809-11	METAL CHIP 100 5%	1/10W
FB800	1-216-864-11	SHORT CHIP 0		R633	1-216-809-11	METAL CHIP 100 5%	1/10W
FB802	1-216-864-11	SHORT CHIP 0		R636	1-216-809-11	METAL CHIP 100 5%	1/10W
FB881	1-216-295-11	SHORT CHIP 0		R639	1-216-835-11	METAL CHIP 15K 5%	1/10W
		< FILTER >		R644	1-216-864-11	SHORT CHIP 0	
FL800	1-234-177-21	FILTER, CHIP EMI		R645	1-216-864-11	SHORT CHIP 0	
FL810	1-234-177-21	FILTER, CHIP EMI		R648	1-216-809-11	METAL CHIP 100 5%	1/10W
		< IC >		R651	1-216-791-11	METAL CHIP 3.3 5%	1/10W
IC600	6-707-939-01	IC CXD9843AR		R652	1-216-791-11	METAL CHIP 3.3 5%	1/10W
IC630	6-707-629-01	IC CXD9845M		R653	1-216-791-11	METAL CHIP 3.3 5%	1/10W
IC802	6-701-189-01	IC MC74VHC1GU04DFT1		R654	1-216-800-11	METAL CHIP 18 5%	1/10W
IC810	6-700-263-01	IC NJM2870F18(TE2)		R655	1-216-800-11	METAL CHIP 18 5%	1/10W
IC880	8-759-422-21	IC NJM4580V(TE2)		R656	1-216-800-11	METAL CHIP 18 5%	1/10W
		< JUMPER RESISTOR >		R657	1-216-800-11	METAL CHIP 18 5%	1/10W
JR800	1-216-864-11	SHORT CHIP 0		R658	1-216-791-11	METAL CHIP 3.3 5%	1/10W
				R681	1-216-790-11	METAL CHIP 2.7 5%	1/10W
				R683	1-216-790-11	METAL CHIP 2.7 5%	1/10W
				R691	1-216-790-11	METAL CHIP 2.7 5%	1/10W
				R697	1-216-790-11	METAL CHIP 2.7 5%	1/10W
				R803	1-216-857-11	METAL CHIP 1M 5%	1/10W
				R804	1-216-864-11	SHORT CHIP 0	
				R805	1-216-864-11	SHORT CHIP 0	
				R806	1-216-864-11	SHORT CHIP 0	

Ref. No.	Part No.	Description	Remark	Ref. No.	Part No.	Description	Remark	
R807	1-216-864-11	SHORT CHIP	0	C1885	1-126-916-11	ELECT 1000uF 20%	6.3V	
R808	1-216-864-11	SHORT CHIP	0	C1886	1-126-960-11	ELECT 1uF 20%	50V	
R810	1-216-864-11	SHORT CHIP	0	C1887	1-126-916-11	ELECT 1000uF 20%	6.3V	
R811	1-216-845-11	METAL CHIP	100K 5%	1/10W	C1888	1-162-927-11	CERAMIC CHIP 100PF 5%	50V
R820	1-216-837-11	METAL CHIP	22K 5%	1/10W	< CONNECTOR >			
R821	1-216-828-11	METAL CHIP	3.9K 5%	1/10W	* CN1880	1-564-710-11	PIN, CONNECTOR (SMALL TYPE) 8P	
R824	1-216-837-11	METAL CHIP	22K 5%	1/10W	CN1966	1-779-273-11	CONNECTOR, FFC (LIF(NON-ZIF)) 5P	
R825	1-216-837-11	METAL CHIP	22K 5%	1/10W	< GROUND TERMINAL >			
R827	1-216-864-11	SHORT CHIP	0	EPT1970	1-537-738-21	TERMINAL, GROUND		
R840	1-216-845-11	METAL CHIP	100K 5%	1/10W	< JUMPER RESISTOR >			
R841	1-216-864-11	SHORT CHIP	0	FB1976	1-216-864-11	SHORT CHIP	0	
R842	1-216-864-11	SHORT CHIP	0	FB1979	1-216-864-11	SHORT CHIP	0	
R843	1-216-864-11	SHORT CHIP	0	< IC >				
R844	1-216-864-11	SHORT CHIP	0	IC1800	6-600-495-01	IC MM1671XNRE		
R845	1-216-864-11	SHORT CHIP	0	IC1802	8-759-653-07	IC PQ09RD21J00H		
R860	1-216-845-11	METAL CHIP	100K 5%	1/10W	IC1803	6-707-921-01	IC PQ3RD13J000H	
R861	1-216-845-11	METAL CHIP	100K 5%	1/10W	IC1804	8-759-471-81	IC PQ05RD11J00H	
R862	1-216-845-11	METAL CHIP	100K 5%	1/10W	< JACK >			
R865	1-216-845-11	METAL CHIP	100K 5%	1/10W	J1900	1-774-227-11	JACK, PIN 1P (VIDEO OUT)	
R866	1-216-845-11	METAL CHIP	100K 5%	1/10W	< JUMPER RESISTOR >			
R867	1-216-845-11	METAL CHIP	100K 5%	1/10W	JR1914	1-216-864-11	SHORT CHIP 0	
R868	1-216-841-11	METAL CHIP	47K 5%	1/10W	< COIL >			
R869	1-216-841-11	METAL CHIP	47K 5%	1/10W	L1950	1-414-183-41	INDUCTOR 10uH	
R880	1-216-837-11	METAL CHIP	22K 5%	1/10W	< TRANSISTOR >			
R881	1-216-837-11	METAL CHIP	22K 5%	1/10W	Q1970	8-729-027-43	TRANSISTOR DTC114EKA-T146	
R882	1-216-837-11	METAL CHIP	22K 5%	1/10W	Q1971	8-729-027-43	TRANSISTOR DTC114EKA-T146	
R883	1-216-837-11	METAL CHIP	22K 5%	1/10W	< RESISTOR >			
R885	1-216-839-11	METAL CHIP	33K 5%	1/10W	R1940	1-216-833-11	METAL CHIP 10K 5%	1/10W
R886	1-216-864-11	SHORT CHIP	0	R1941	1-218-285-11	METAL CHIP 75 5%	1/10W	
R887	1-216-837-11	METAL CHIP	22K 5%	1/10W	R1942	1-216-845-11	METAL CHIP 100K 5%	1/10W
R888	1-216-837-11	METAL CHIP	22K 5%	1/10W	R1947	1-216-833-11	METAL CHIP 10K 5%	1/10W
R889	1-216-837-11	METAL CHIP	22K 5%	1/10W	*****			
R890	1-216-837-11	METAL CHIP	22K 5%	1/10W	VOLUME BOARD			
R891	1-216-839-11	METAL CHIP	33K 5%	1/10W	*****			
R892	1-216-864-11	SHORT CHIP	0	< CAPACITOR >				
R893	1-216-826-11	METAL CHIP	2.7K 5%	1/10W	C1334	1-164-360-11	CERAMIC CHIP 0.1uF	16V
R894	1-216-825-11	METAL CHIP	2.2K 5%	1/10W	< DIODE >			
R895	1-216-837-11	METAL CHIP	22K 5%	1/10W	D1309	6-500-809-01	LED SELU5223C-STP15	(RING ILLUMINATION)
< VIBRATOR >				< JUMPER RESISTOR >				
X801	1-795-660-21	QUARTZ CRYSTAL UNIT (49MHZ)	*****					
*****				*****				
A-1164-023-A	VIDEO BOARD, COMPLETE		*****					
*****				< CAPACITOR >				
7-685-646-79	SCREW +BVTP 3X8 TYPE2 TT (B)		*****					
*****				< DIODE >				
C1850	1-126-916-11	ELECT	1000uF 20%	6.3V	D1312	6-500-809-01	LED SELU5223C-STP15	(RING ILLUMINATION)
C1851	1-126-960-11	ELECT	1uF 20%	50V	< JUMPER RESISTOR >			
C1871	1-216-864-11	SHORT CHIP	0	JR1300	1-216-864-11	SHORT CHIP	0	
C1876	1-162-970-11	CERAMIC CHIP	0.01uF 10%	25V	JR1301	1-216-864-11	SHORT CHIP	0
C1878	1-164-156-11	CERAMIC CHIP	0.1uF 25V	*****				
C1881	1-104-658-11	ELECT	100uF 20%	10V	*****			
C1882	1-126-960-11	ELECT	1uF 20%	50V	*****			
C1883	1-126-926-11	ELECT	1000uF 20%	10V	*****			
C1884	1-126-960-11	ELECT	1uF 20%	50V	*****			

HCD-GNZ55D

VOLUME

Ref. No.	Part No.	Description	Remark
JR1302	1-216-864-11	SHORT CHIP 0	
		< RESISTOR >	
R1310	1-216-864-11	SHORT CHIP 0	
R1329	1-216-823-11	METAL CHIP 1.5K 5% 1/10W	
R1333	1-216-821-11	METAL CHIP 1K 5% 1/10W	
R1334	1-216-823-11	METAL CHIP 1.5K 5% 1/10W	
R1335	1-216-825-11	METAL CHIP 2.2K 5% 1/10W	
R1336	1-216-829-11	METAL CHIP 4.7K 5% 1/10W	
R1337	1-216-833-11	METAL CHIP 10K 5% 1/10W	
R1368	1-216-821-11	METAL CHIP 1K 5% 1/10W	
R1369	1-216-821-11	METAL CHIP 1K 5% 1/10W	
R1370	1-216-821-11	METAL CHIP 1K 5% 1/10W	
R1377	1-216-821-11	METAL CHIP 1K 5% 1/10W	
R1378	1-216-821-11	METAL CHIP 1K 5% 1/10W	
R1379	1-216-821-11	METAL CHIP 1K 5% 1/10W	
		< SWITCH >	
S1305	1-418-725-41	ENCODER, ROTARY (12 TYPE) (MASTER VOLUME)	
S1306	1-786-289-11	SWITCH, DETECTION (◀◀ OPERATION DIAL ▶▶)	
S1318	1-762-875-21	SWITCH, KEYBOARD (EQ BAND/MEMORY)	
S1319	1-762-875-21	SWITCH, KEYBOARD (SOUND FIELD)	
S1328	1-762-875-21	SWITCH, KEYBOARD (RESET EQ)	
S1331	1-762-875-21	SWITCH, KEYBOARD (GROOVE)	

		MISCELLANEOUS *****	
6	1-828-955-11	WIRE (FLAT TYPE) (9 CORE)	
52	1-417-657-11	MECHA DECK	
58	1-829-030-11	WIRE (FLAT TYPE) (25 CORE)	
59	1-827-720-11	WIRE (FLAT TYPE) (11 CORE)	
△205	1-479-627-11	POWER UNIT	
207	1-828-985-11	WIRE (FLAT TYPE) (15 CORE)	
△209	1-824-642-21	CORD, POWER (WITH CONNECTOR) (TH)	
△209	1-830-188-11	CORD, POWER (EXCEPT TH)	
252	1-828-589-11	WIRE (FLAT TYPE) (13 CORE)	
253	1-828-286-11	WIRE (FLAT TYPE) (5 CORE)	
254	1-828-614-11	WIRE (FLAT TYPE) (17 CORE)	
302	1-776-182-11	WIRE (FLAT TYPE) (5 CORE)	
353	1-828-973-11	WIRE (FLAT TYPE) (13 CORE)	
370	1-828-252-51	WIRE (FLAT TYPE) (24 CORE)	
△371	8-820-291-02	OPTICAL PICK-UP (KHM-310CAB/C2RP)	
FC901	1-500-497-11	FILTER, CLAMP (FERRITE CORE)	
M741	A-1108-965-A	MOTOR ASSY, TABLE (TABLE)	
M751	A-1108-966-A	MOTOR ASSY, LOADING (LOADING)	
RE701	1-477-680-12	ENCODER, ROTARY (DISC TRAY ADDRESS DETECT)	
TU901	1-693-702-11	TUNER (FM/AM) (TM10SE)	

MEMO

