

# HCD-GTR6/GTR6B/GTR7/ GTR8/GTR8B

## SERVICE MANUAL

Ver. 1.2 2010.09

*E Model*  
HCD-GTR6/GTR6B/GTR7/GTR8/GTR8B

*Australian Model*  
HCD-GTR6B/GTR8B



Photo : HCD-GTR8B (E Model)

- HCD-GTR6/GTR7/GTR8 are the tuner, CD and amplifier section in MHC-GTR6/GTR7/GTR8
- HCD-GTR6B/GTR8B are the tuner, deck, CD and amplifier section in MHC-GTR6/GTR7/GTR8

CD Section	Model Name Using Similar Mechanism	NEW
	CD Mechanism Type	CDM74HF-DVBU101//M
	Optical Pick-up Name	KHM-313CAB/C2NP
Tape Deck Section only for HCD-GTR6B/GTR8B	Model Name Using Similar Mechanism	HCD-GTX777/GTX787/GTX888
	Tape Mechanism Type	CFP42608

### SPECIFICATIONS

#### AUDIO POWER SPECIFICATION

##### Amplifier section MHC-GTR8 (HCD-GTR8/HCD-GTR8B)

The following are measured at  
 Mexican model: AC 127 V, 60 Hz  
 Other models: AC 120, 220, 240 V, 50/60 Hz

Front/Surround speaker  
 Power Output (rated): 210 W + 210 W (at 6 Ω, 1 kHz, 1% THD, at LINK MODE)

Front speaker  
 RMS output power (reference):  
 280 W + 280 W (per channel at 8 Ω,  
 1 kHz, 10% THD)

Surround speaker  
 RMS output power (reference):  
 110 W + 110 W (per channel at 24 Ω,  
 1 kHz, 10% THD)

Subwoofer  
 RMS output power (reference):  
 160 W + 160 W (per channel at 6 Ω,  
 100 Hz, 10% THD)

##### MHC-GTR7 (HCD-GTR7)

The following are measured at  
 Mexican model: AC 127 V, 60 Hz  
 Other models: AC 120, 220, 240 V, 50/60 Hz

Front/Surround speaker  
 Power Output (rated): 215 W + 215 W (at 6 Ω, 1 kHz, 1% THD, at LINK MODE)

Front speaker  
 RMS output power (reference):  
 285 W + 285 W (per channel at 8 Ω, 1 kHz, 10% THD)

Surround speaker  
 RMS output power (reference): 110 W + 110 W (per channel at 24 Ω,  
 1 kHz, 10% THD)

Subwoofer  
 RMS output power (reference): 210 W (at 8 Ω, 100 Hz, 10% THD)

– Continued on next page –

## COMPACT DISC DECK RECEIVER

9-890-515-03  
 2010I08-1  
 © 2010. 09

**Sony Corporation**  
 Published by Sony EMCS (Malaysia) PG Tec

# SONY®

# HCD-GTR6/GTR6B/GTR7/GTR8/GTR8B

## MHC-GTR6 (HCD-GTR6/HCD-GTR6B)

The following are measured at

AC 120, 220, 240 V, 50/60 Hz

Front/Surround speaker

Power Output (rated): 200 W + 200 W (at 4 Ω, 1 kHz, 1% THD, at LINK MODE)

Front speaker

RMS output power (reference):

225 W + 225 W (per channel at 8 Ω, 1 kHz, 10% THD)

Surround speaker

RMS output power (reference):

225 W + 225 W (per channel at 8 Ω, 1 kHz, 10% THD)

Inputs

VIDEO (AUDIO IN) L/R:

Voltage 250 mV, impedance 47 kilohms

PC IN L/R:

Voltage 700 mV, impedance 47 kilohms

MIC:

Sensitivity 1 mV, impedance 10 kilohms

● (USB) port:

Type A

Outputs

PHONES: Accepts headphones of 8 Ω or more

## Disc player section

System Compact disc and digital audio system

Laser Diode Properties Emission Duration: Continuous

Laser Output\*: Less than 44.6 μW

\* This output is the value measurement

at a distance of 200 mm from the

objective lens surface on the Optical

Pick-up Block with 7 mm aperture.

Frequency response

20 Hz – 20 kHz

Signal-to-noise ratio

More than 90 dB

Dynamic range

More than 88 dB

## Tape deck section

(Except for Latin American and Mexican models)

Recording system 4-track 2-channel stereo

## Tuner section

FM stereo, FM/AM superheterodyne tuner

## FM tuner section

Tuning range

North American models:

87.5 – 108.0 MHz (100 kHz step)

Other models:

87.5 – 108.0 MHz (50 kHz step)

Antenna

FM lead antenna

Antenna terminals

75 ohms unbalanced

Intermediate frequency

10.7 MHz

## AM tuner section

Tuning range

Pan-American and Oceanian models:

530 – 1,710 kHz (with the interval set at 10 kHz)

531 – 1,710 kHz (with the interval set at 9 kHz)

Other models:

530 – 1,610 kHz (with the interval set at 10 kHz)

531 – 1,602 kHz (with the interval set at 9 kHz)

Antenna

AM loop antenna

Antenna terminals

External antenna terminal

Intermediate frequency

450 kHz

## USB section

Supported bit rate

MP3 (MPEG 1 Audio Layer 3): 32 – 320 kbps, VBR

WMA: 48 – 192 kbps AAC: 48 – 320 kbps

Sampling frequencies

MP3 (MPEG 1 Audio Layer 3): 32/44.1/48 kHz

WMA: 44.1 kHz

AAC: 44.1 kHz

Transfer speed

Full-Speed

Supported USB device

Mass Storage Class

Maximum current

500 mA

## General

Power requirements

Mexican model:

127 V AC, 60 Hz

Australian model:

230 – 240 V AC, 50/60 Hz

Argentina model:

220 V AC, 50/60 Hz

Other models:

120 V, 220 V or 230 – 240 V AC, 50/60 Hz,

adjustable with voltage selector

Power consumption

MHC-GTR8: 460 W

MHC-GTR7: 440 W

MHC-GTR6: 300 W

Dimensions (w/h/d) (Approx.)

HCD-GTR8/HCD-GTR8B/

HCD-GTR7/

HCD-GTR6/HCD-GTR6B: 295x380x457mm

Mass (Approx.)

HCD-GTR8B: 16.5 kg

HCD-GTR8/HCD-GTR7: 15.8 kg

HCD-GTR6B: 14.5 kg

HCD-GTR6: 13.8 kg

Design and specifications are subject to change without notice.

- Standby power consumption: 0.5 W
- Halogenated flame retardants are not used in the certain printed wiring boards.

## SAFETY-RELATED COMPONENT WARNING!!

COMPONENTS IDENTIFIED BY MARK  $\triangle$  OR DOTTED LINE WITH MARK  $\triangle$  ON THE SCHEMATIC DIAGRAMS AND IN THE PARTS LIST ARE CRITICAL TO SAFE OPERATION. REPLACE THESE COMPONENTS WITH SONY PARTS WHOSE PART NUMBERS APPEAR AS SHOWN IN THIS MANUAL OR IN SUPPLEMENTS PUBLISHED BY SONY.

**Notes on Chip Component Replacement**

- Never reuse a disconnected chip component.
- Notice that the minus side of a tantalum capacitor may be damaged by heat.

**Flexible Circuit Board Repairing**

- Keep the temperature of soldering iron around 270°C during repairing.
- Do not touch the soldering iron on the same conductor of the circuit board (within 3 times).
- Be careful not to apply force on the conductor when soldering or unsoldering.

**UNLEADED SOLDER**

Boards requiring use of unleaded solder are printed with the lead free mark (LF) indicating the solder contains no lead.  
 (Caution: Some printed circuit boards may not come printed with the lead free mark due to their particular size)

**LF: LEAD FREE MARK**

- Unleaded solder has the following characteristics.
- Unleaded solder melts at a temperature about 40 °C higher than ordinary solder.  
 Ordinary soldering irons can be used but the iron tip has to be applied to the solder joint for a slightly longer time.  
 Soldering irons using a temperature regulator should be set to about 350 °C.  
 Caution: The printed pattern (copper foil) may peel away if the heated tip is applied for too long, so be careful!
  - Strong viscosity  
 Unleaded solder is more viscou-s (sticky, less prone to flow) than ordinary solder so use caution not to let solder bridges occur such as on IC pins, etc.
  - Usable with ordinary solder  
 It is best to use only unleaded solder but unleaded solder may also be added to ordinary solder.

**CAUTION**  
 Use of controls or adjustments or performance of procedures other than those specified herein may result in hazardous radiation exposure.

**NOTES ON HANDLING THE OPTICAL PICK-UP BLOCK OR BASE UNIT**

The laser diode in the optical pick-up block may suffer electrostatic breakdown because of the potential difference generated by the charged electrostatic load, etc. on clothing and the human body. During repair, pay attention to electrostatic break-down and also use the procedure in the printed matter which is included in the repair parts.  
 The flexible board is easily damaged and should be handled with care.

**NOTES ON LASER DIODE EMISSION CHECK**

The laser beam on this model is concentrated so as to be focused on the disc reflective surface by the objective lens in the optical pick-up block. Therefore, when checking the laser diode emission, observe from more than 30 cm away from the objective lens.

Laser component in this product is capable of emitting radiation exceeding the limit for Class 1.

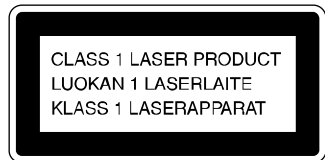

This appliance is classified as a CLASS 1 LASER product. This label is located on the rear exterior.

# HCD-GTR6/GTR6B/GTR7/GTR8/GTR8B

## MODEL IDENTIFICATION

– MODEL NUMBER LABEL –

- Abbreviation
- E2 : 120V AC area in E model
- E3 : 240V AC area in E model
- E51 : Chilean and Peruvian model
- AR : Argentina model
- AUS : Australian model
- MX : Mexican model

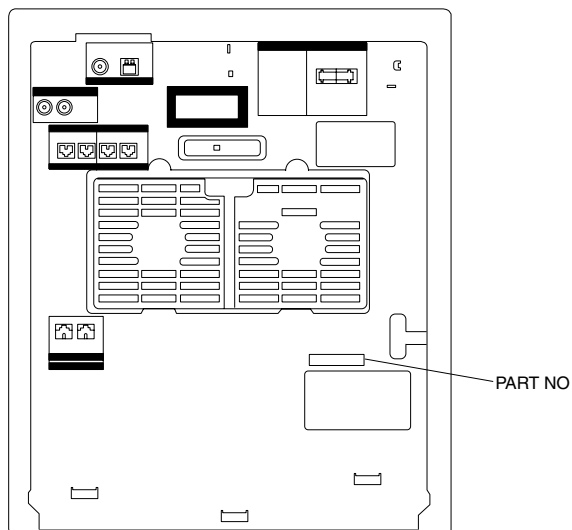

MODEL	Parts No
GTR8B: E3	4-126-681-0□
GTR8: E2/E51	4-126-681-1□
GTR8: AR	4-126-681-3□
GTR8B: AUS	4-126-681-5□
GTR8: MX	4-126-681-6□
GTR7: E2/E51	4-135-808-1□
GTR7: AR	4-135-808-3□
GTR7: MX	4-135-808-4□
GTR6B: E3	4-135-809-0□
GTR6: E2/E51	4-135-809-1□
GTR6B: AR	4-135-809-3□
GTR6B: AUS	4-135-809-4□

## TABLE OF CONTENTS

**1. DISASSEMBLY**

1-1. Case (Top).....	7
1-2. Tape Mechanism Deck.....	7
1-3. Loading panel.....	8
1-4. Front Panel Section.....	8
1-5. MIC Board, USB Board, MICRV Board, Headphone Board.....	9
1-6. Display Board, STR Board, CD SW Board.....	9
1-7. Tuner pack.....	10
1-8. Subtrans Board.....	10
1-9. DC Fan, Power Transformer (T1200).....	11
1-10. Main Board, Front Boars Section.....	11
1-11. Front Board, GTH Subwoofer Board.....	12
1-12. Back Panel Section, DC Fan.....	12
1-13. CD Block Section.....	13
1-14. DMB-19 Board, GTH HUB Board.....	13
1-15. Driver MT Board, SW MT Board.....	14
1-16. Optical Pick-up.....	14
1-17. Sensor Board.....	15
1-18. Motor(TB) Board.....	15
1-19. Motor (LD) Board.....	16

<b>2. TEST MODE .....</b>	<b>17</b>
---------------------------	-----------

<b>3. MECHANICAL ADJUSTMENTS .....</b>	<b>19</b>
--	-----------

<b>4. ELECTRICAL ADJUSTMENTS .....</b>	<b>20</b>
--	-----------

**5. DIAGRAMS**

5-1. Block Diagram — USB Section —.....	22
5-2. Block Diagram — RF/Servo Section —.....	23
5-3. Block Diagram — Tape/Tuner Section —.....	24
5-4. Block Diagram — Main Section —.....	25
5-5. Block Diagram — AMP/Subwoofer Section —.....	26
5-6. Block Diagram — Display/Power Section —.....	27
5-7. Circuit Boards Location.....	28
5-8. Printed Wiring Board — Display Board —.....	30
5-9. Schematic Diagram — Display Board —.....	31
5-10. Printed Wiring Boards — DMB19 Board —.....	32
5-11. Schematic Diagram — DMB19 Board (1/4) —.....	33
5-12. Schematic Diagram — DMB19 Board (2/4) —.....	34
5-13. Schematic Diagram — DMB19 Board (3/4) —.....	35
5-14. Schematic Diagram — DMB19 Board (4/4) —.....	36
5-15. Printed Wiring Board — Front Board —.....	37
5-16. Schematic Diagram — Front Board —.....	38
5-17. Printed Wiring Board — Main Board —.....	39
5-18. Schematic Diagram — Main Board (1/5) —.....	40
5-19. Schematic Diagram — Main Board (2/5) —.....	41
5-20. Schematic Diagram — Main Board (3/5) —.....	42
5-21. Schematic Diagram — Main Board (4/5) —.....	43
5-22. Schematic Diagram — Main Board (5/5) —.....	44
5-23. Printed Wiring Board — MIC and MIC RV Board —.....	45
5-24. Schematic Diagram — MIC and MIC RV Board —.....	46
5-25. Printed Wiring Board — STR and CD_SW Board —.....	47
5-26. Schematic Diagram — STR and CD_SW Board —.....	48
5-27. Printed Wiring Board — Trans and Sub Trans Board —.....	49
5-28. Schematic Diagram — Trans and Sub Trans Board —.....	50
5-29. Printed Wiring Board — Sub Woofer Board —.....	51
5-30. Schematic Diagram — Sub Woofer Board —.....	52
5-31. Printed Wiring Boards — Headphone and USB CD Board —.....	53
5-32. Schematic Diagram — Headphone and USB CD Board —.....	54
5-33. Printed Wiring Board — HUB Board —.....	55
5-34. Schematic Diagram — HUB Board —.....	56
5-35. Printed Wiring Board — DRIVER Board —.....	57
5-36. Printed Wiring Board — DRIVER Board —.....	58

**6. EXPLODED VIEWS**

6-1. Main Section.....	66
6-2. Back Panel Section.....	67
6-3. Front Panel Section (1).....	68
6-4. Front Panel Section (2).....	69
6-5. Chassis Section.....	70
6-6. CD Mechanism Section (1).....	71
6-7. CD Mechanism Section (2).....	72

<b>7. ELECTRICAL PARTS LIST .....</b>	<b>73</b>
---------------------------------------	-----------

## SECTION 1 DISASSEMBLY

Note : This set can be disassembled in the order shown below.

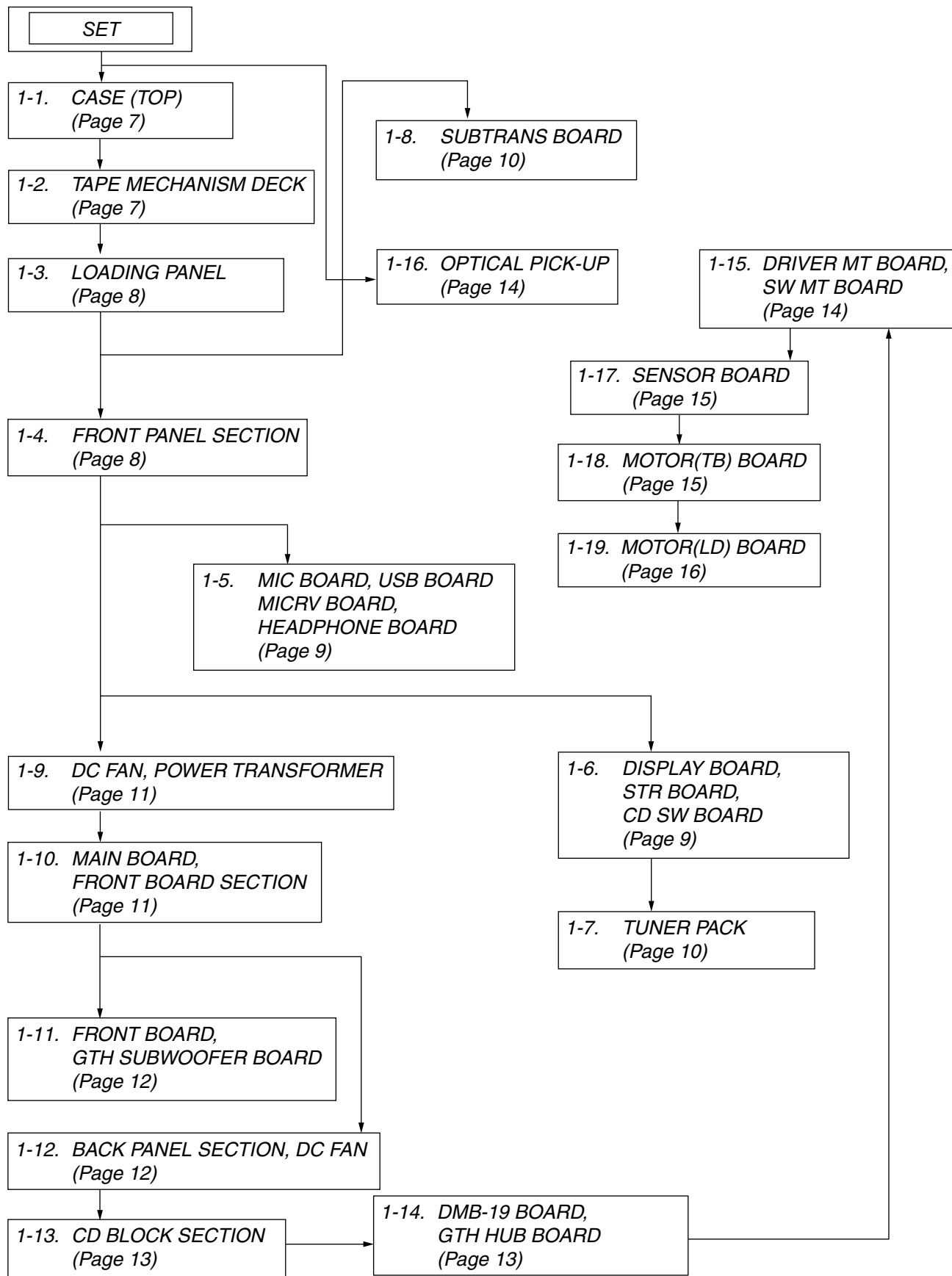

Note : Follow the disassembly procedure in the numerical order given.

## 1-1. CASE (TOP)

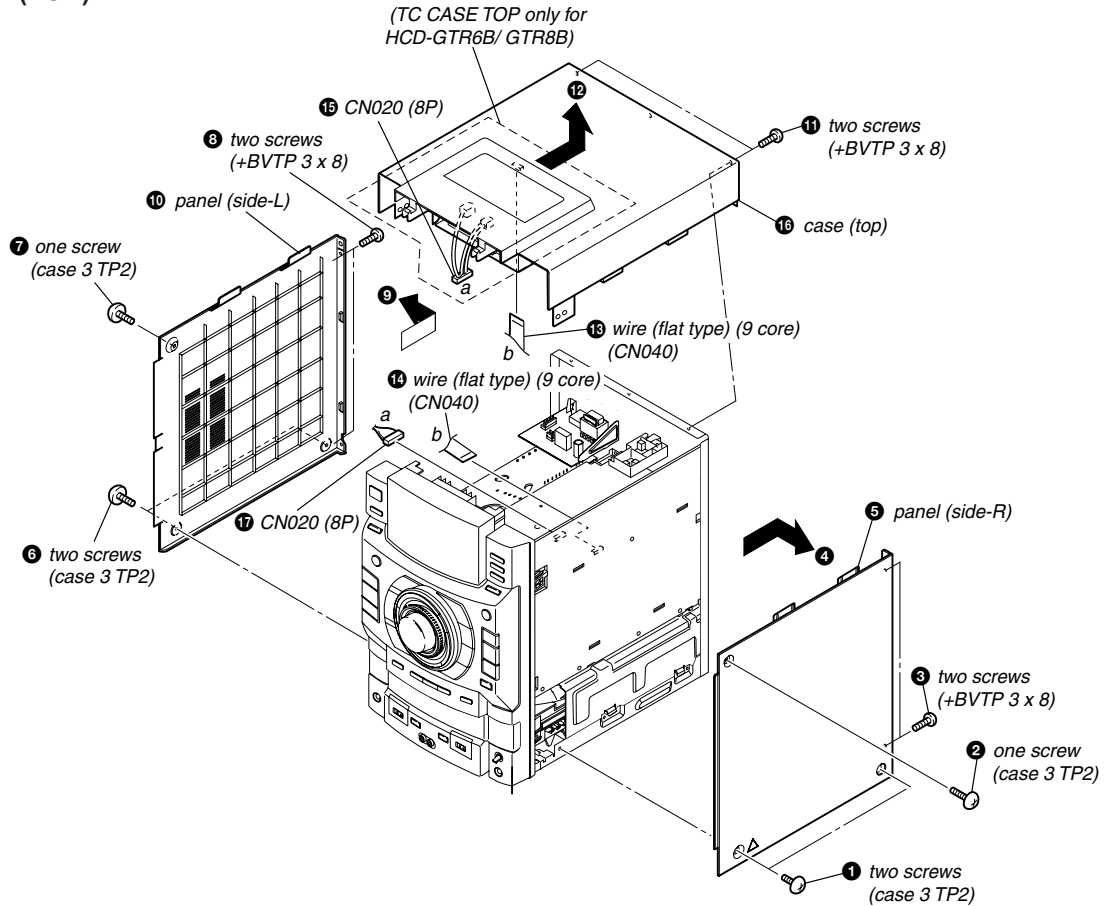

## 1-2. TAPE MECHANISM DECK (only for HCD-GTR6B/GTR8B)

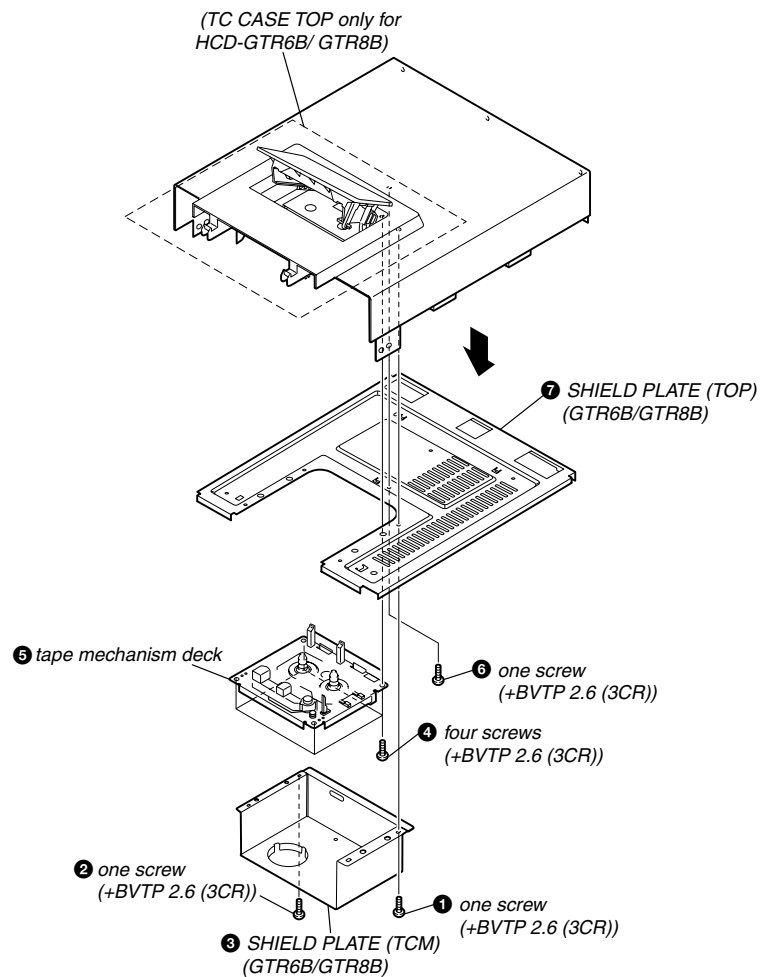

## 1-3. LOADING PANEL

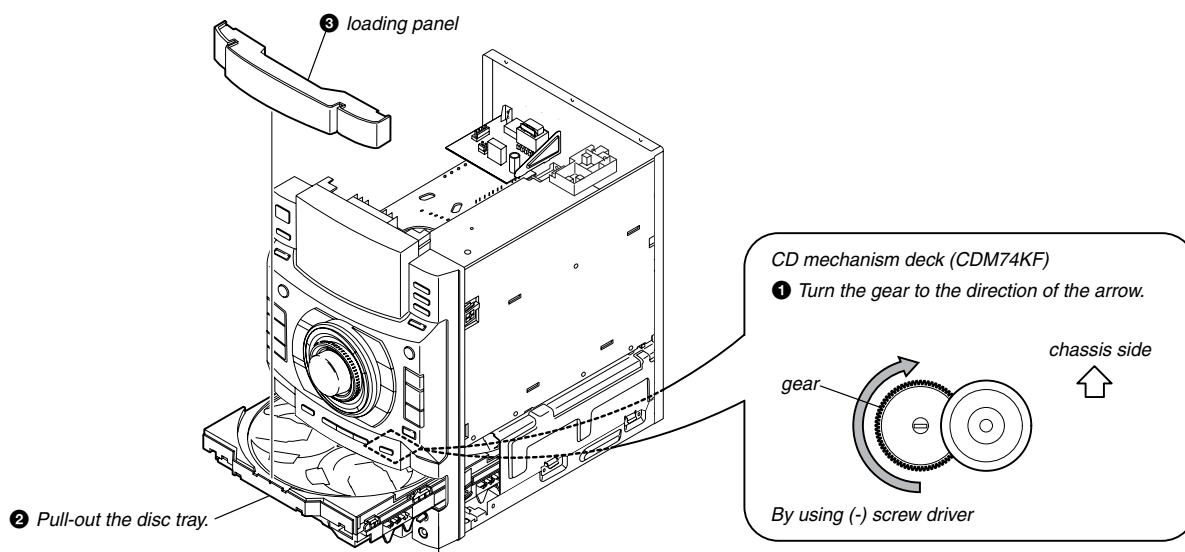

## 1-4. FRONT PANEL SECTION

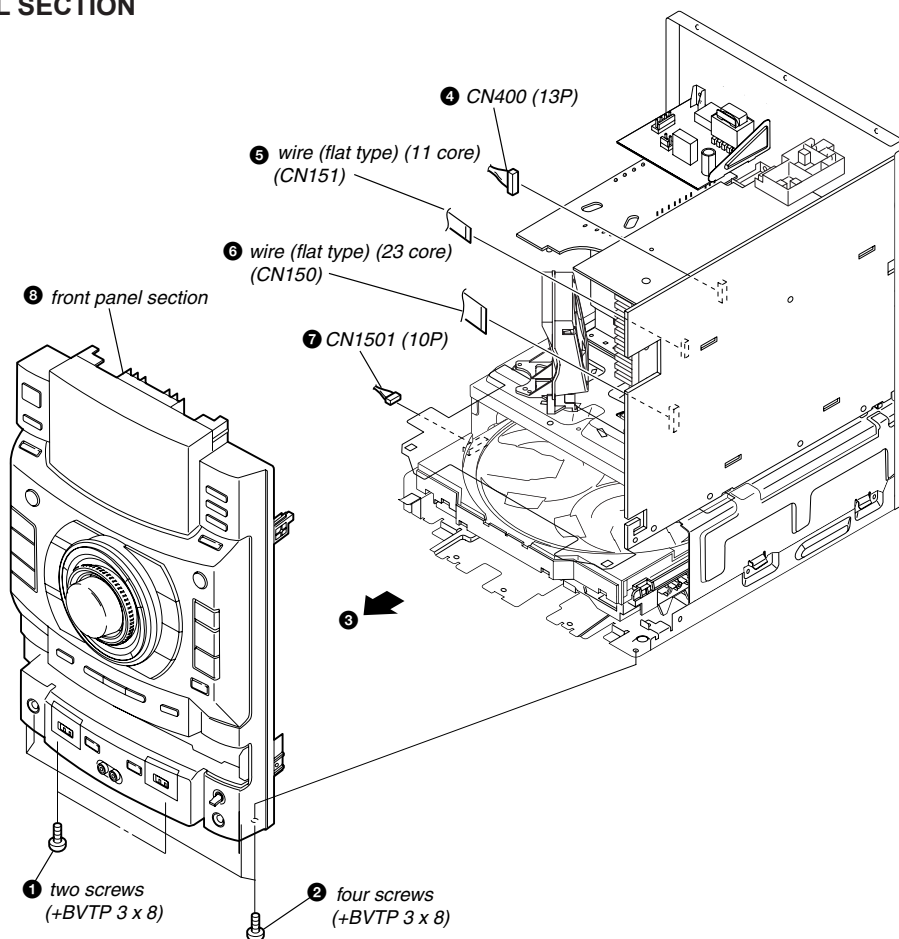



1-5. MIC BOARD, USB BOARD, MICRV BOARD, HEADPHONE BOARD

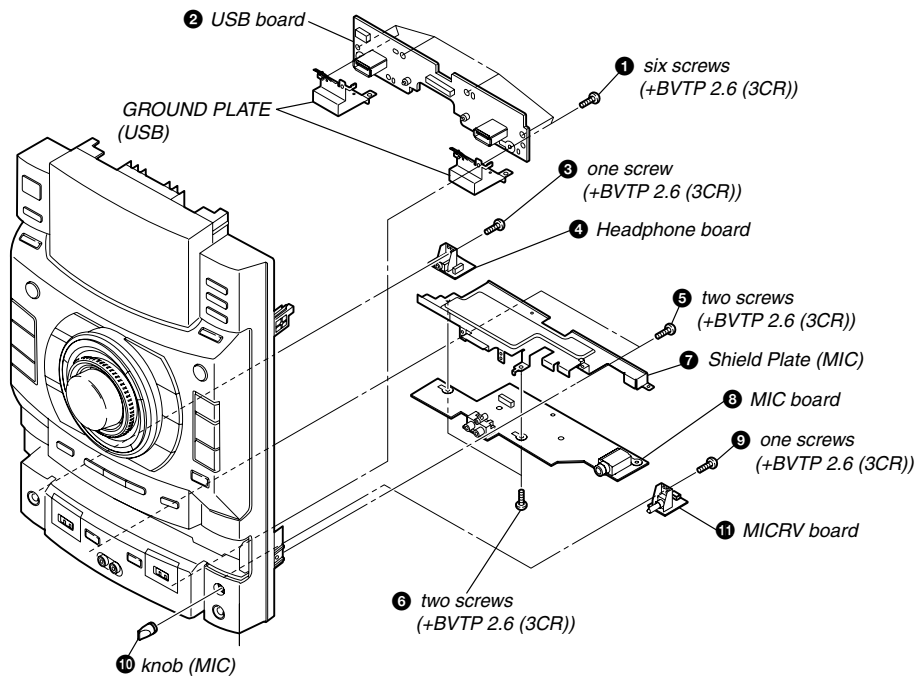

1-6. DISPLAY BOARD, STR BOARD, CD SW BOARD

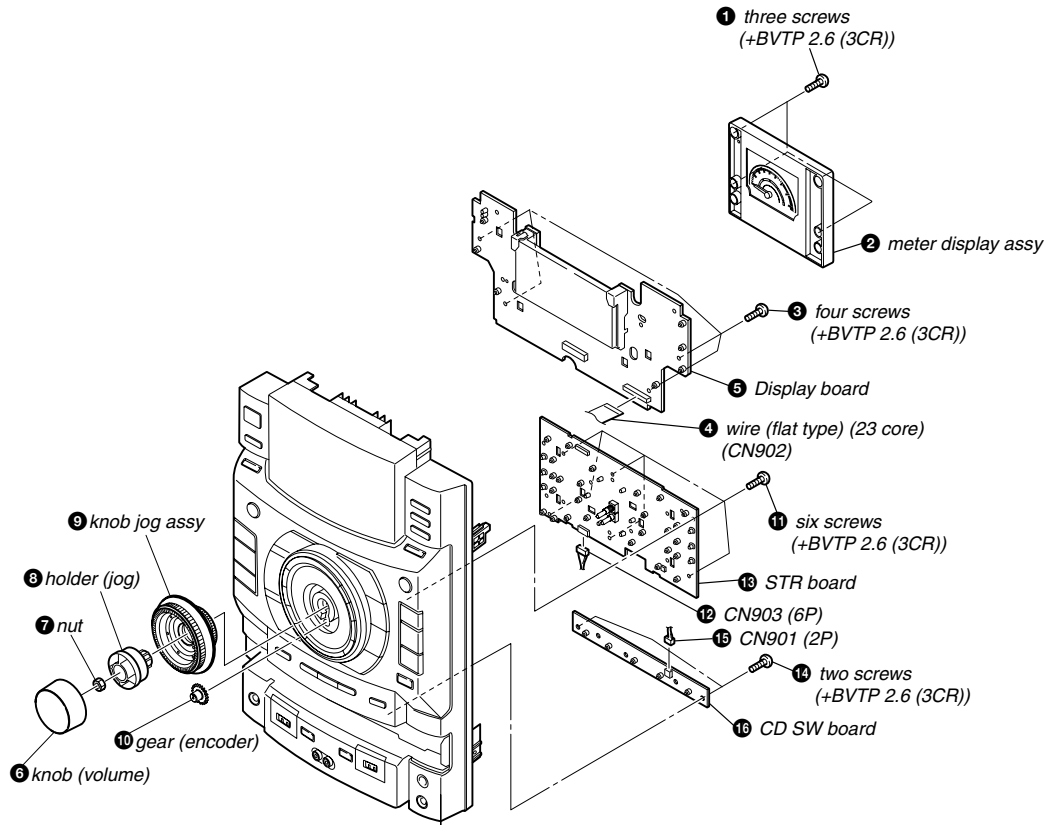

### 1-7. TUNER PACK

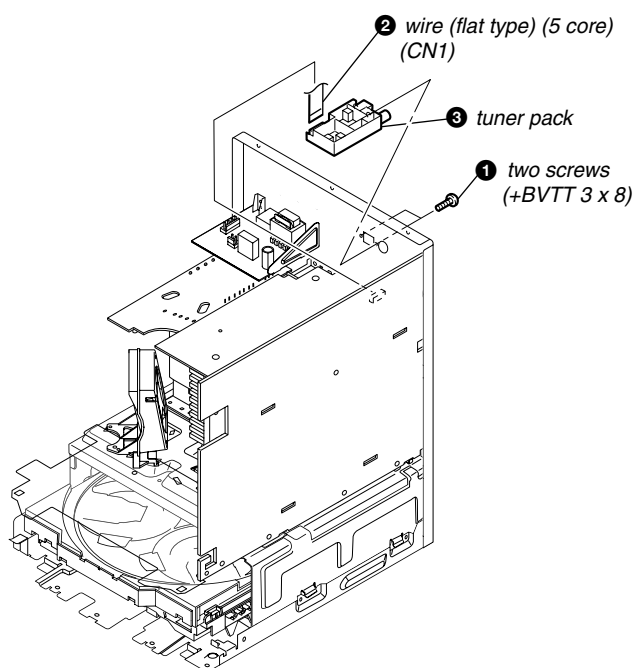

### 1-8. SUBTRANS BOARD

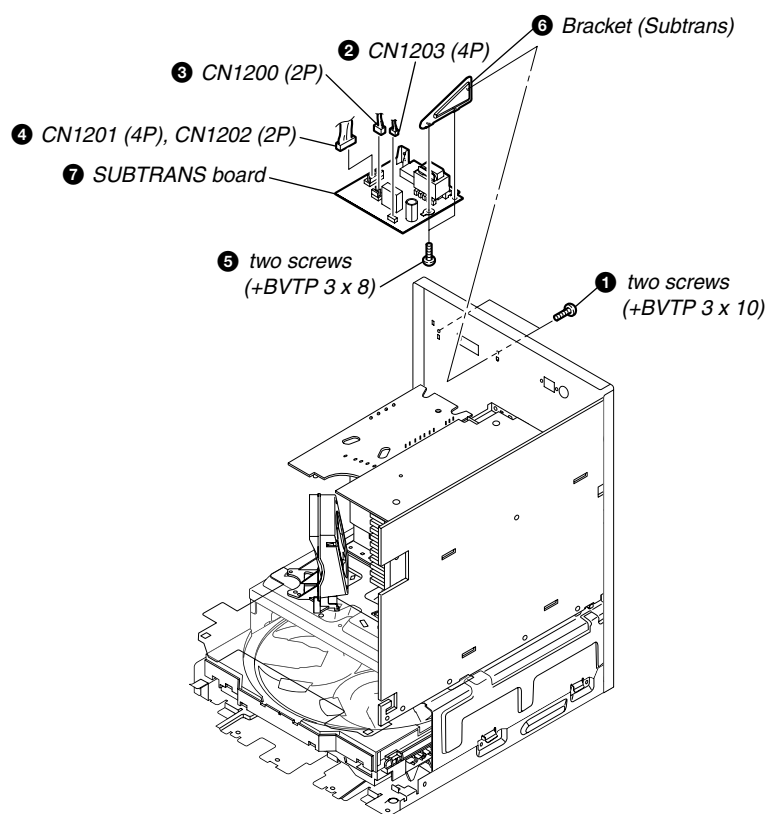

1-9. DC FAN, POWER TRANSFORMER (PT1250)

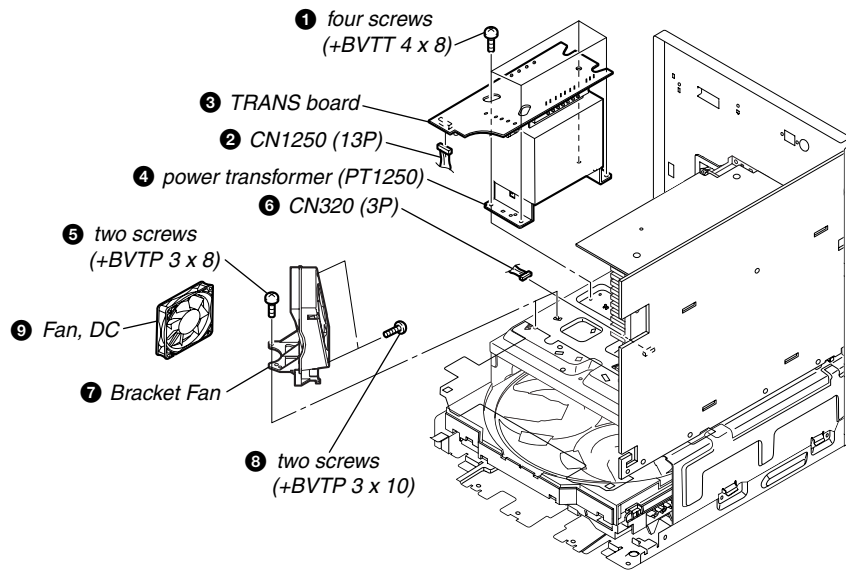

1-10. MAIN BOARD, FRONT BOARD SECTION

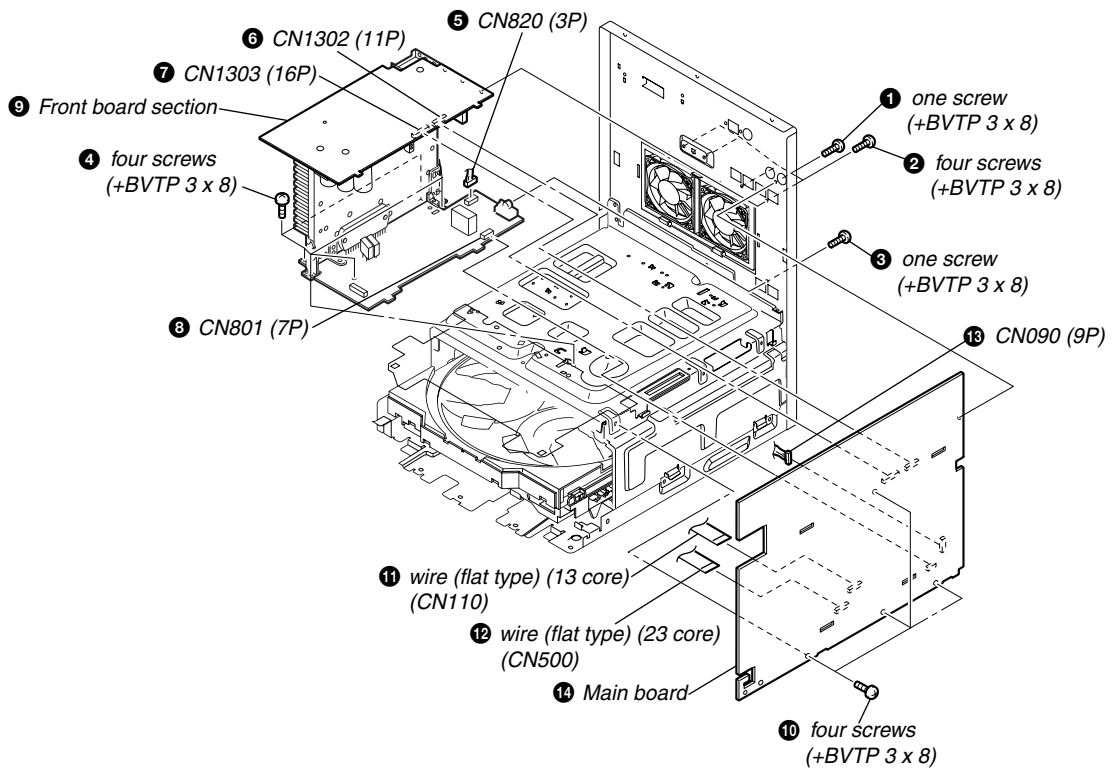

1-11. FRONT BOARD, SUBWOOFER BOARD

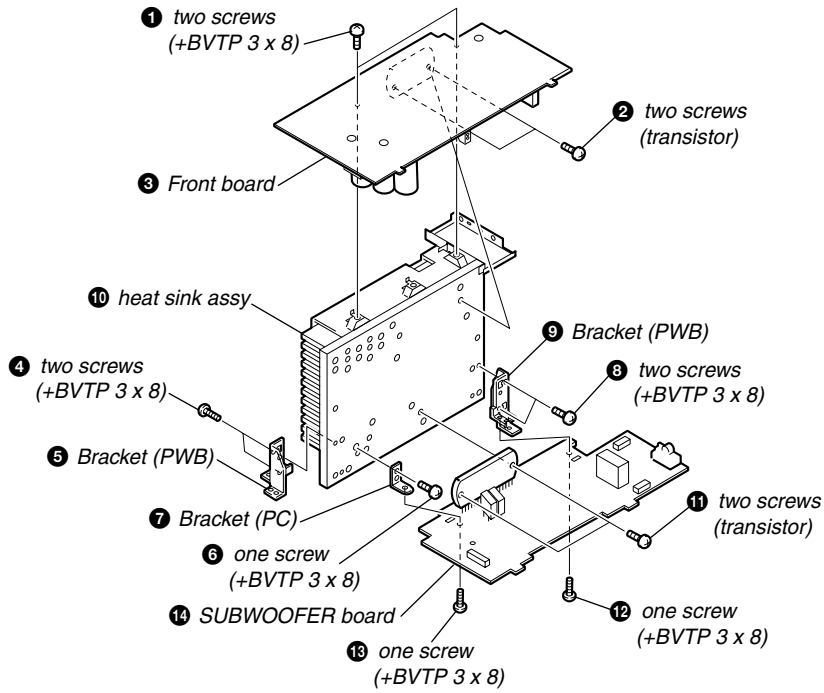

1-12. BACK PANEL SECTION, DC FAN

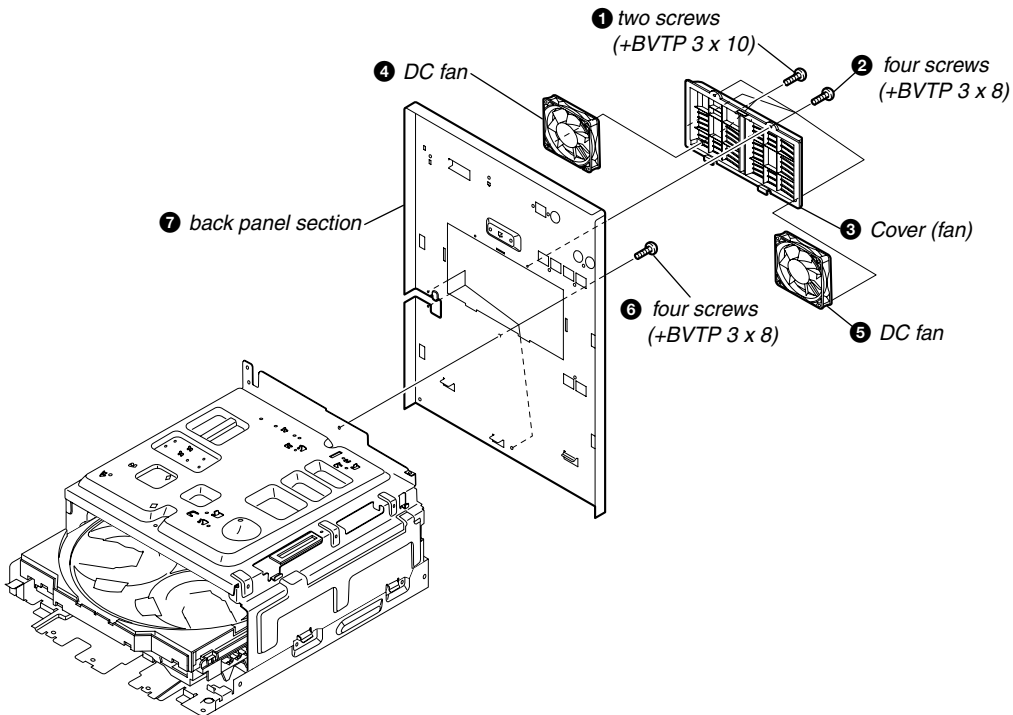

1-13. CD BLOCK SECTION

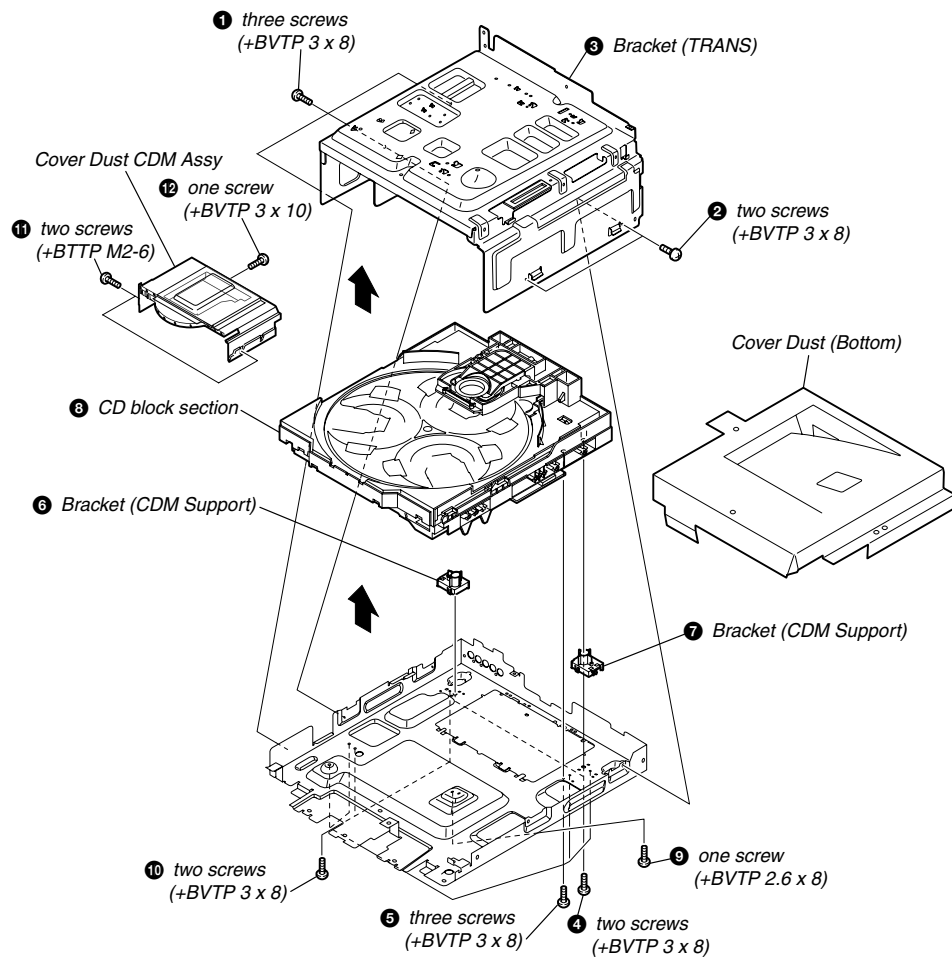

1-14. DMB19 BOARD, GTH HUB BOARD

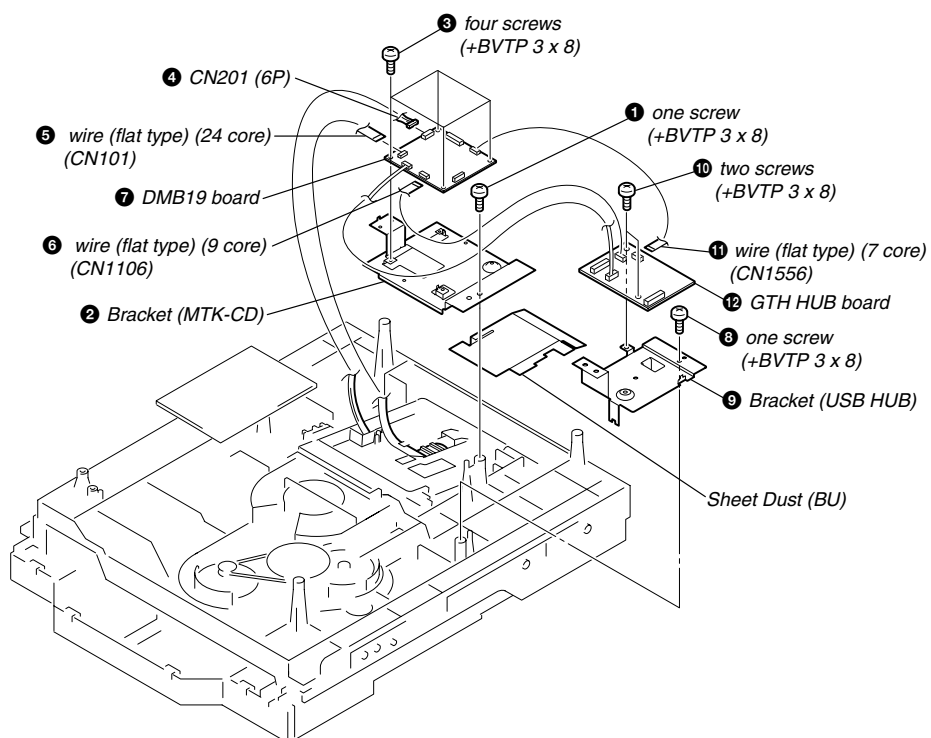

## 1-15. DRIVER MT BOARD, SW MT BOARD

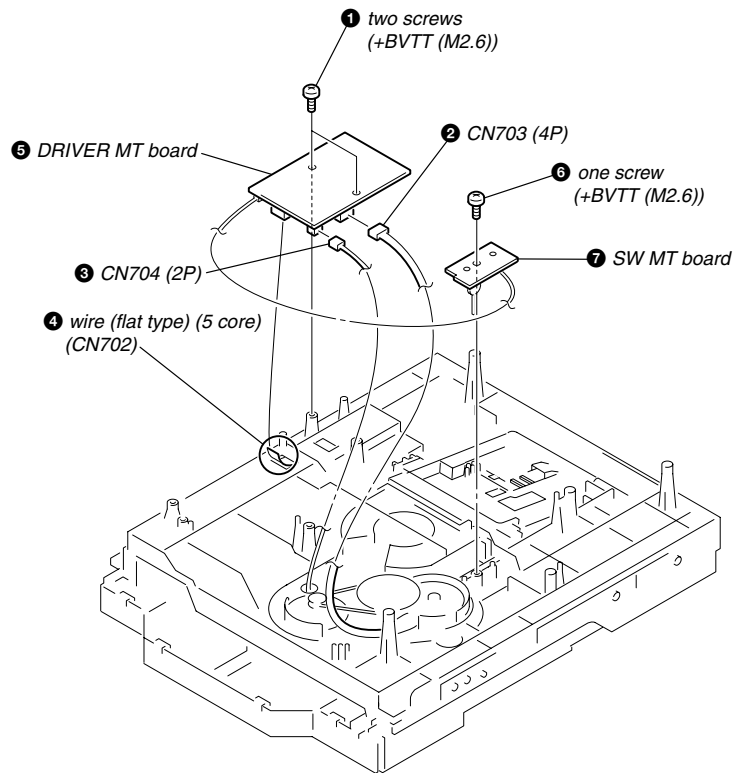

## 1-16. OPTICAL PICK-UP

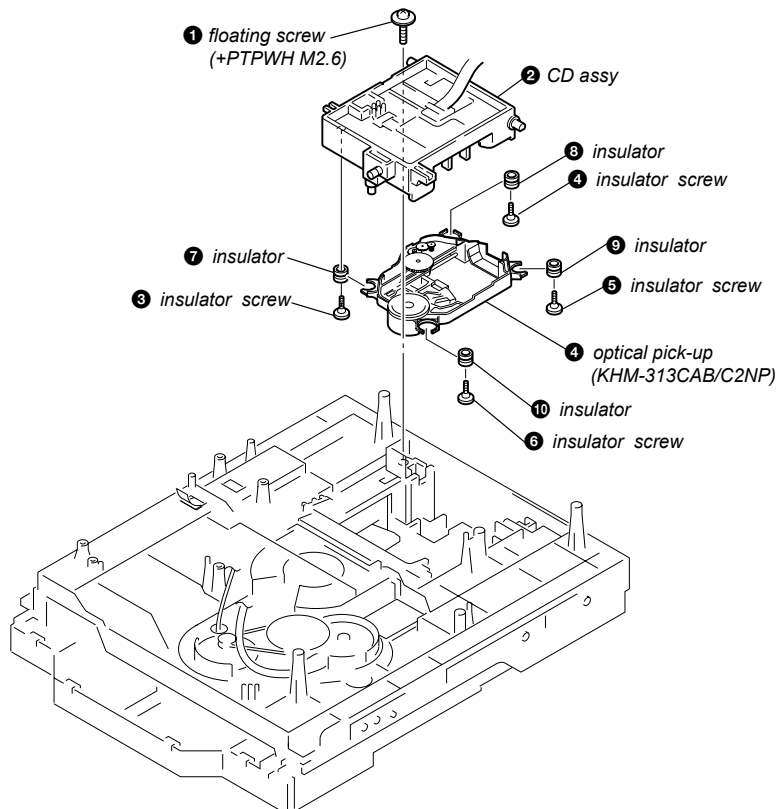

1-17. SENSOR BOARD

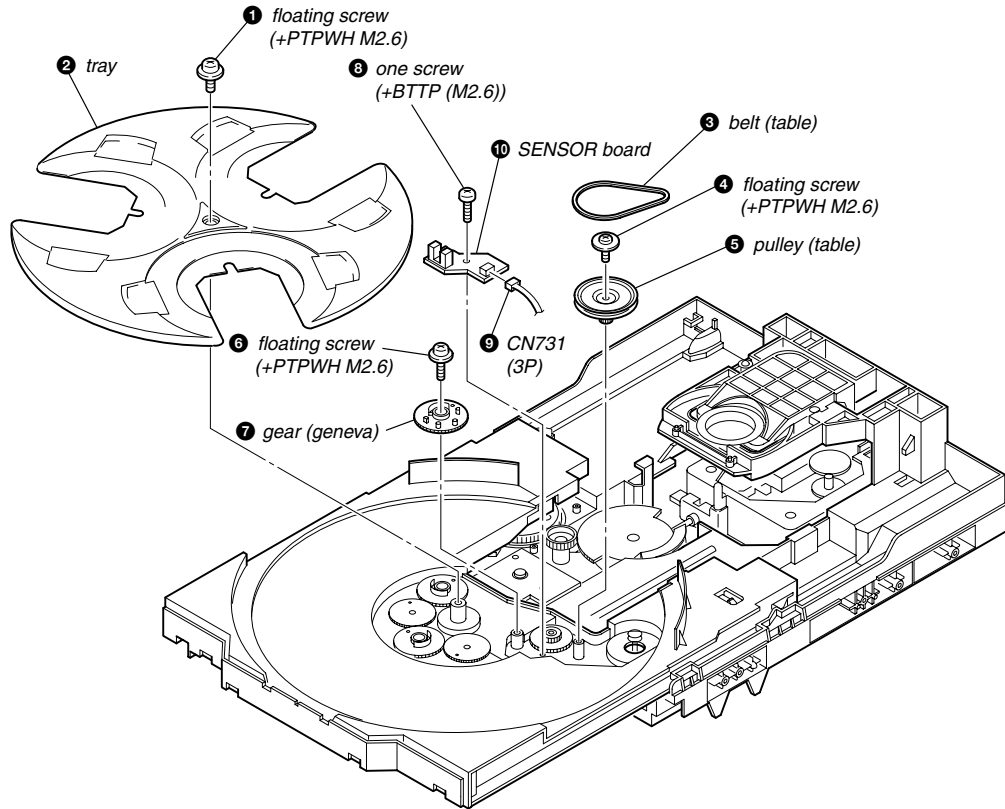

1-18. MOTOR (TB) BOARD

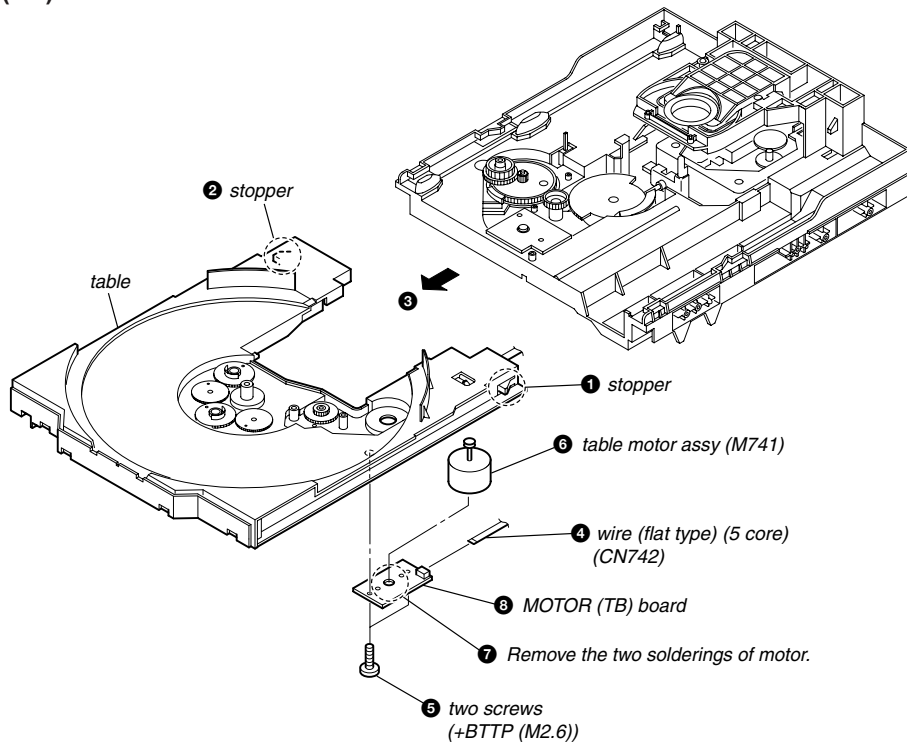

## 1-19. MOTOR (LD) BOARD

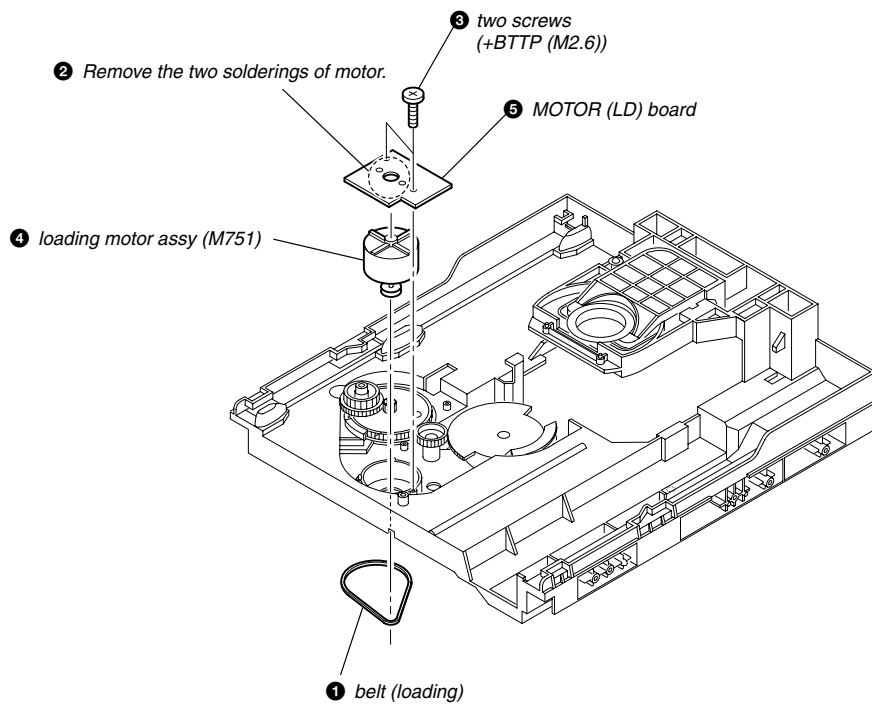



## SECTION 2

### TEST MODE

#### [GC TEST MODE]

- This mode is used to check the fluorescent indicator tube, LEDs, keys, VOLUME jog, OPERATION DIAL jog, model, destination and software version.

#### Procedure:

- Press [■] button, [ENTER] button and [DISC 2] button simultaneously.
- All LEDs and segments in fluorescent indicator tube are lighted up. All LEDs are lighted up in red color except for [B] LED where the LED is lighted up in red and blue color, [A] LED in blue color and SUBWOOFER ON/OFF in green color.
- When you want to enter to the model version and destination display mode, press [DISC 1] button. The model information appears on the fluorescent indicator tube.
- Each time [DISC 1] button is pressed, the display changes to display software version and date of the software creation. The sequence is model destination, SC, MDK, GC, SYS, CD, CDMA, CDMB, ST, TC, TA, TM and MTR in this order, and returns to the model destination display.
- Press [DISC 2] button, the key check mode is activated.
- In the key check mode, the fluorescent indicator tube displays "K 0 J0 V0".  
Turn the [OPERATIONAL DIAL] clockwise; "J" value increases by one. Turn the [OPERATIONAL DIAL] counterclockwise; "J" value decreases by one. Each time a button is pressed, "K" value increases. Press other keys on main unit to check whether the key is detected. However, once a button has been pressed, it is no longer taken into account.  
"V" value increases in the manner of 0,1, 2, 3 ... if [VOLUME] knob is turned clockwise, or it decreases in the manner of 0, 9, 8, 7 ... if [VOLUME] knob is turned counterclockwise.
- When [DISC SKIP/EX-CHANGE] button is pressed after all LEDs and segments in fluorescent indicator tube light up, alternate segments in fluorescent indicator tube and LED would light up. If you press [DISC SKIP/EX-CHANGE] button again, another half of alternate segments in fluorescent indicator tube and LED would light up. Press [DISC SKIP/EX-CHANGE] button again would cause all segments will lights off and press [DISC SKIP/EX-CHANGE] button again all segments will lights up.
- To release from this mode, press three buttons in the same manner as step 1, or disconnect the power cord.

#### [MC TEST MODE]

- This mode is used to check operations of the respective sections of Amplifier and Tape.

#### Procedure:

- To enter MC Test Mode
- Press [■] button, [ENTER] button and [DISC 3] button simultaneously.
  - The CD number indicators flash on the fluorescent indicator tube. The function is changed to VIDEO.
- Check of Amplifier
- Press [EQ BAND] button repeatedly until a message "GEQ MAX" appears on the fluorescent indicator tube. GEQ increases to its maximum.
  - Press [EQ BAND] button repeatedly until a message "GEQ MIN" appears on the fluorescent indicator tube. GEQ decreases to its minimum.
  - Press [EQ BAND] button repeatedly until a message "GEQ FLAT" appears on the fluorescent indicator tube. GEQ is set to flat.

- When the [VOLUME] knob is turned clockwise even slightly, the sound volume increases to its maximum and a message "VOLUME MAX" appears on the fluorescent indicator tube.
- When the [VOLUME] knob is turned counterclockwise even slightly, the sound volume decreases to its minimum and a message "VOLUME MIN" appears on the fluorescent indicator tube.

- Tape function (only for HCD-GTR6B/GTR8B)

- Inserted a tape in deck. The function is changed to VIDEO automatically when the recording is started by pressing [REC TO TAPE] then press [ENTER] button. During recording the ALC (Automatic Logic Control) is turned on.
- During recording, press ALBUM - will stop the recording and the function is changed to TAPE and rewind the tape in Deck until the recording start position and playback of the tape in Deck is started.

- To release from MC Test mode

- To release from this mode, press [POWER] button.
- The cold reset is enforced at the same time.

#### [COLD RESET]

- The cold reset clears all data including preset data stored in the RAM to initial conditions. Execute this mode when returning the set to the customer.

#### Procedure:

- Press [■] button, [ENTER] button, and [POWER] button simultaneously.
- The fluorescent indicator tube becomes blank for a while, and the set is reset.

#### [VACS ON/OFF]

- This mode is used to switch ON and OFF the VACS (Variable Attenuation Control System).

#### Procedure:

- Press [POWER] button to turn the set ON.
- Press [■] button and [OPTIONS] button simultaneously. The message "VACS OFF" or "VACS ON" appears on the fluorescent indicator tube.

#### [TUNER STEP CHANGE]

- The step interval of AM channels can be toggled between 9 KHz and 10 KHz. This mode is not available for Saudi Arabian models.

#### Procedure:

- Press [POWER] button to turn the set ON.
- Press [TUNER/BAND] / [TUNER AM] button to select the "AM".
- Press [POWER] button to turn the set OFF.
- Press [ENTER] button and [POWER] button simultaneously. The system will turn ON automatically. The message "AM 9K STEP" or "AM 10K STEP" appears on the fluorescent indicator tube and thus the channel step is changed.

## [CD SHIP MODE (WITH MEMORY CLEAR)]

- This mode moves the optical pick-up to the position durable to vibration and clears all data including preset data stored in the RAM to initial conditions. Use this mode when returning the set to the customer after repair.

### Procedure:

1. Press [POWER] button to turn the set ON.
2. Select CD function and waiting until CD no disc confirm.
3. Press [■] button, [SOUND FLASH] button and [POWER] button simultaneously. The set will power off automatically.
4. After the “STANDBY” blinking display finishes, a message “MECHA LOCK” is displayed on the fluorescent indicator tube and the CD ship mode is set.
5. Then AC power OFF.

## [CD SHIP MODE (WITHOUT MEMORY CLEAR)]

- This mode moves the optical pick-up to the position durable to vibration. Use this mode when returning the set to the customer after repair.

### Procedure:

1. Press [POWER] button to turn the set ON.
2. Select CD function.
3. Press [CD] button and [POWER] button simultaneously. The set will power off automatically.
4. After the “STANDBY” blinking display finishes, a message “MECHA LOCK” is displayed on the fluorescent indicator tube and the CD ship mode is set.
5. The AC power OFF.

## [CD TRAY LOCK MODE / DISC THEFT PREVENTION]

- This mode let you lock the disc tray. When this mode is activated, the disc tray will not open when [OPEN/CLOSE] button or [EX-CHANGE] button is pressed. The message “LOCKED” will be displayed on the fluorescent indicator tube.

### Procedure:

1. Press [POWER] button to turn the set ON.
2. Select CD function.
3. Press [■] button and [OPEN/CLOSE] button simultaneously and hold down until “LOCKED” or “UNLOCKED” displayed on the fluorescent indicator tube (around 5 seconds).

## [TCM OFFLINE MODE] (only for HCD-GTR6B/GTR8B)

- This mode prevents set from power off automatically when TCM is not connected. Therefore, measurements can be done even when TCM is not connected.

### Procedure:

1. When the system in turned off, press [EQ BAND/MEMORY] button, [STOP] button and [POWER] button simultaneously. The set will power on automatically.
2. The message “TCM OFFLINE” will be displayed on the fluorescent indicator tube.

## [VACS DISPLAY]

- This mode is used to check the VACS level.

### Procedure:

1. Press [POWER] button to turn on the system.
2. Press [■] button, [SOUND FLASH] button and [DISC SKIP/EX-CHANGE] button simultaneously.

3. The VACS Level Display, the fluorescent indicator tube displays “VATB F APC”. “V” represent VACS , A represent VACS level which is triggered by signal level, “T” represent Thermal VACS NEO, B represent VACS level which is triggered by temperature, “F” represent FAN is triggered by software to turn in to high speed, “AP” represent APVACS (Abuse Protection VACS) and “C” represent APVACS level which is triggered.

## [METER AGING TEST MODE]

- This mode use in factory to perform the non-stop aging mode for meter device.

### Procedure:

1. Press [POWER] button to turn on the system.
2. Press [EQ BAND/MEMORY] button and [METER MODE] button simultaneously.

## [ERROR MESSAGE]

### 1. METER ERROR CODE CHECK

- This mode is used to check the number of trigger for Meter Pointer to initial switch and end switch. The switches will trigger during meter initialize in AC supply on condition.

### Procedure:

1. Press [POWER] button to turn on the system.
2. Press [■] button, [EQ BAND/MEMORY] button and [METER MODE] button simultaneously.

The Meter Error Code will appear on the fluorescent indicator tube displays

- Display

Display on fluorescent indicator tube,

IxxxxxMyyyyy

Ixxxxx = total number of Initial Switch touch by Meter pointer. The Initial Switch will touch twice during meter initialized process.

Myyyyy = total number of End Switch touch by Meter pointer. The End Switch will touch one times during meter initialized process.

## SECTION 3 MECHANICAL ADJUSTMENTS

(only for HCD-GTR6B/GTR8B)

### Precaution

1. Clean the following parts with a denatured alcohol-moistened swab:
 

record/playback heads	pinch rollers
erase head	rubber belts
capstan	idlers
2. Demagnetize the record/playback head with a head demagnetizer.
3. Do not use a magnetized screwdriver for the adjustments.
4. After the adjustments, apply suitable locking compound to the parts adjusted.
5. The adjustments should be performed with the rated power supply voltage unless otherwise noted.

### Torque Measurement

Mode	Torque meter	Meter reading
FWD	CQ-102C	2.9m N • m to 6.9m N • m 30 to 70 g • cm (0.42 – 0.97 oz • inch)
FWD back tension	CQ-102C	0.15m N • m to 0.59m N • m 2 to 6 g • cm (0.03 – 0.08 oz • inch)
REV	CQ-102RC	2.9m N • m to 6.9m N • m 30 to 70 g • cm (0.42 – 0.97 oz • inch)
REV back tension	CQ-102RC	0.15m N • m to 0.59m N • m 2 to 6 g • cm (0.03 – 0.08 oz • inch)
FF/REW	CQ-201B	4.8m N • m to 16.7m N • m 49 to 170 g • cm (0.68 – 2.36 oz • inch)

## SECTION 4 ELECTRICAL ADJUSTMENTS

**TUNER SECTION**      0 dB = 1  $\mu$ V

[FM Tune Level Check]

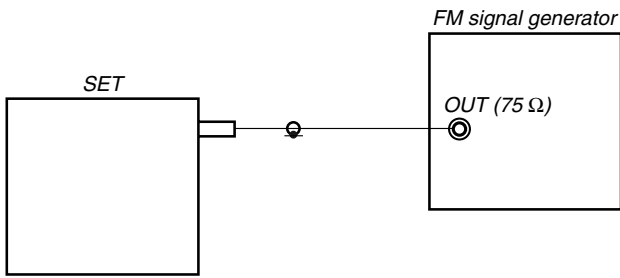

**Procedure:**

1. Turn the power on.
2. Input the following signal from Signal Generator to FM antenna input directly.

\* Carrier Freq: A = 87.5 MHz, B = 98 MHz, C = 108 MHz  
 Deviation : 75 kHz  
 Modulation : 1 kHz  
 ANT input : 35 dBu (EMF)

**Note:** Please use 75 ohm "coaxial cable" to connect SG and the set. You cannot use video cable for checking.  
 Please use SG whose output impedance is 75 ohm.

3. Set to FM tuner function and tune A, B and C signals.
4. Confirm "TUNED" is lit on the display for A, B and C signals.

The mark of "TUNED" means "The selected station signal is received in good condition."

**DECK SECTION**      0 dB = 0.775 V

(only for HCD-GTR6B/GTR8B)

1. Demagnetize the record/playback head with a head demagnetizer.
2. Do not use a magnetized screwdriver for the adjustments.
3. After the adjustments, apply suitable locking compound to the parts adjust.
4. The adjustments should be performed with the rated power supply voltage unless otherwise noted.
5. The adjustments should be performed in the order given in this service manual. (As a general rule, playback circuit adjustment should be completed before performing recording circuit adjustment.)
6. The adjustments should be performed for both L-CH and R-CH.
7. Switches and controls should be set as follows unless otherwise specified.

- Test Tape

Tape	Signal	Used for
P-4-A100	10 kHz, -10 dB	Azimuth Adjustment

### [RECORD/PLAYBACK HEAD AZIMUTH ADJUSTMENT]

**Note:** Perform this adjustments for Single deck

**Procedure:**

1. Mode: Playback

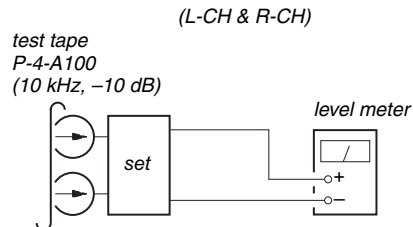

2. Turn the adjustment screw and check output peaks. If the peaks do not match for L-CH and R-CH, turn the adjustment screw so that outputs match within 1dB of peak.

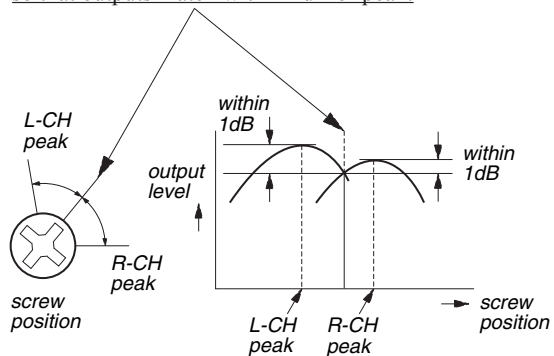

3. Mode: Playback

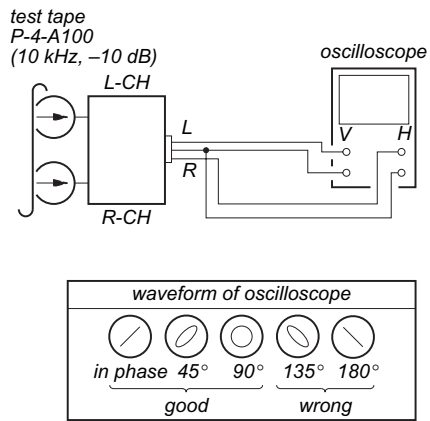

4. After the adjustments, apply suitable locking compound to the parts adjusted.

**Adjustment Location:** Playback Head (Deck).

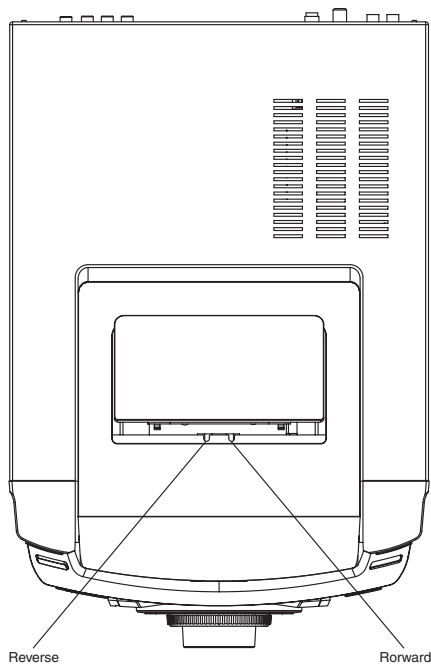

## SECTION 5 DIAGRAMS

### 5-1. BLOCK DIAGRAM — USB SECTION —

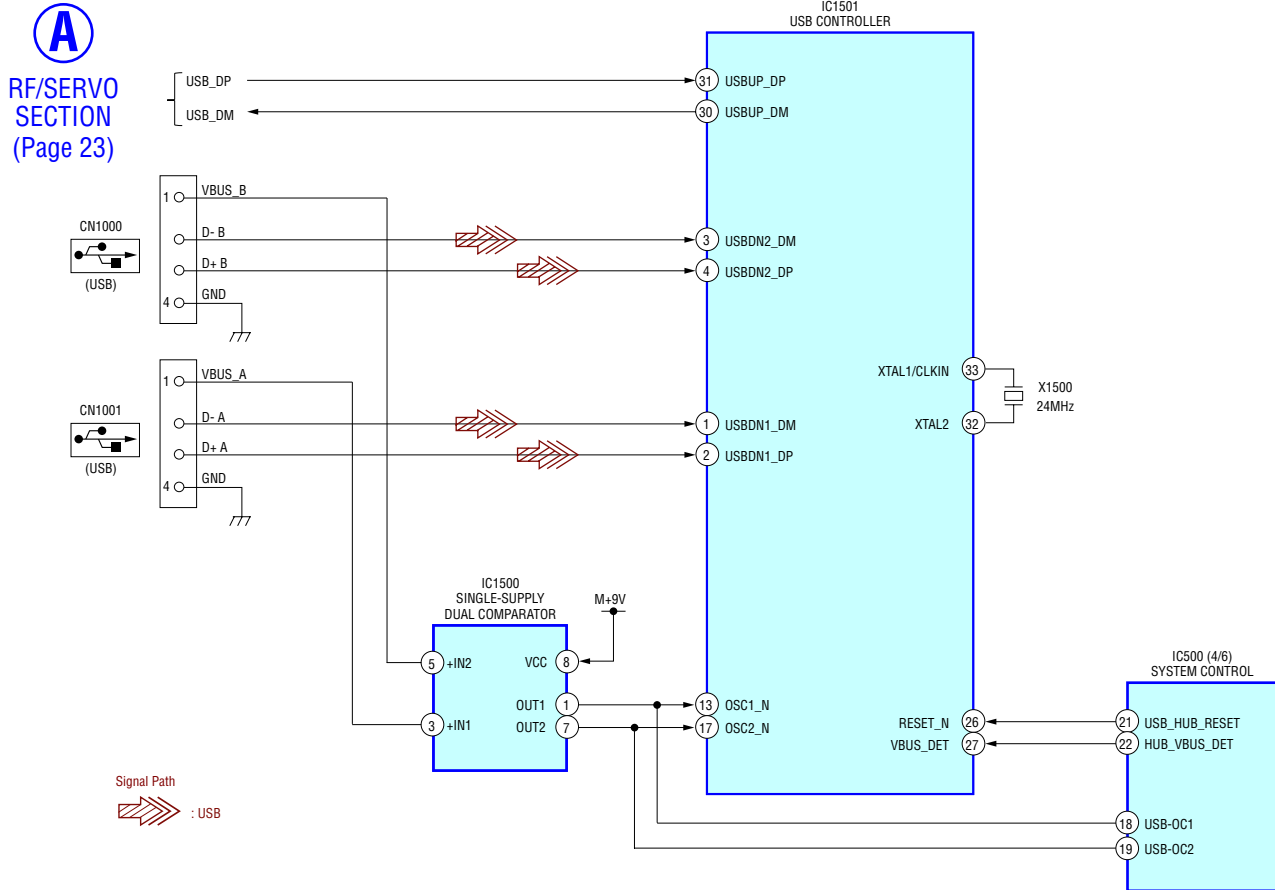

5-2. BLOCK DIAGRAM — RF/SERVO SECTION —

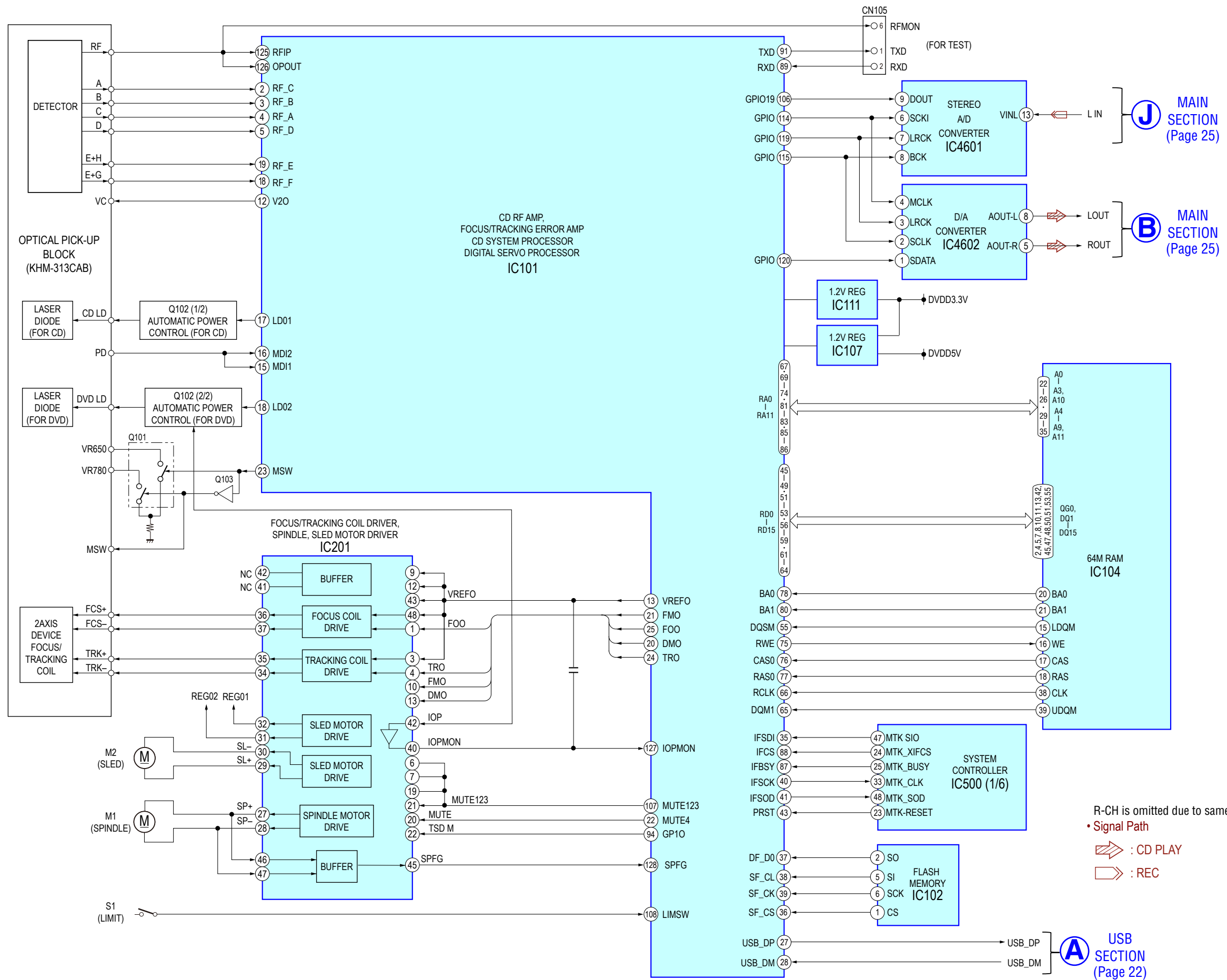

R-CH is omitted due to same as L-CH.  
 • Signal Path  
 : CD PLAY  
 : REC

5-3. BLOCK DIAGRAM — TAPE/TUNER SECTION —

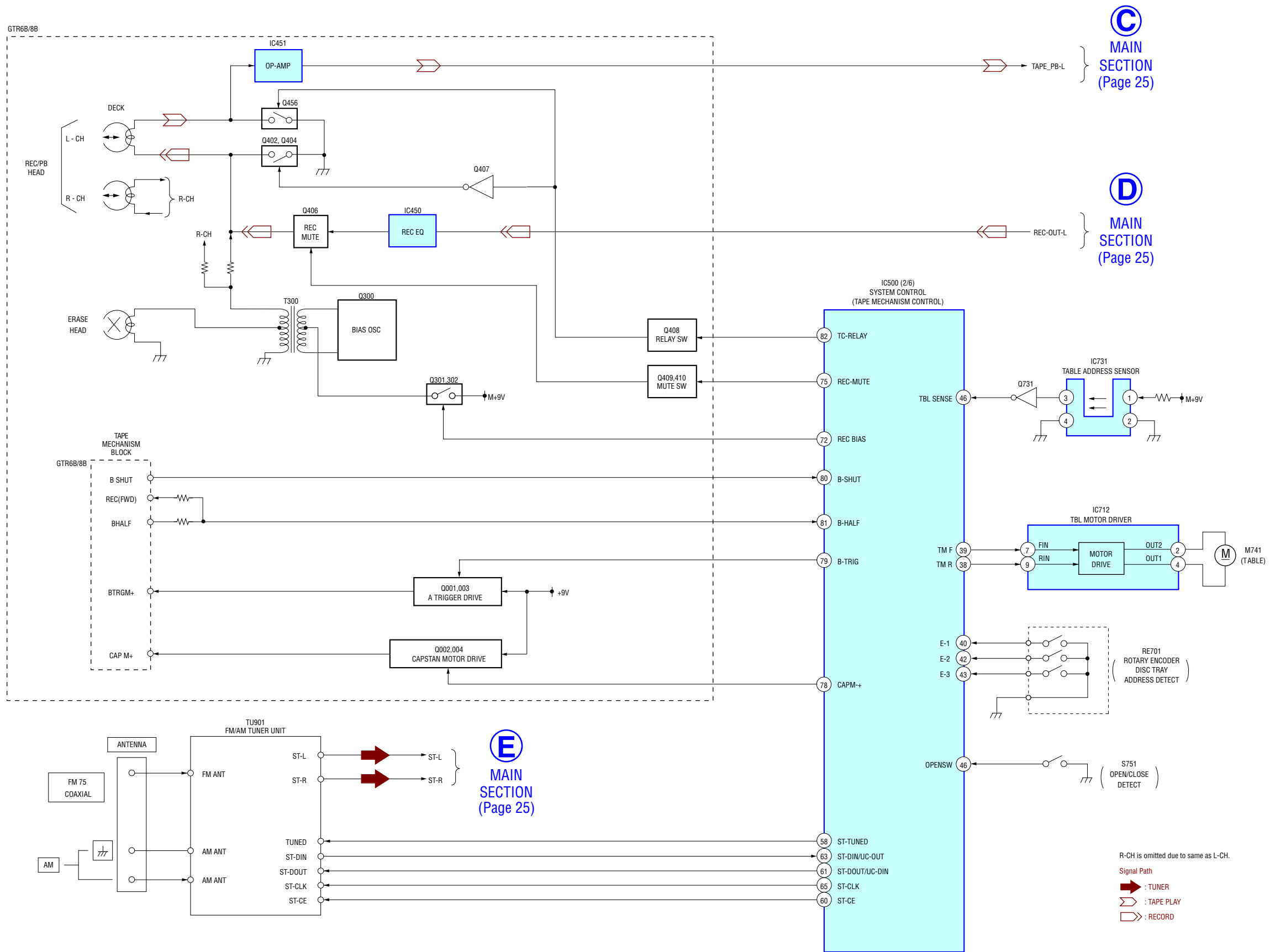

**C**  
 MAIN SECTION  
 (Page 25)

**D**  
 MAIN SECTION  
 (Page 25)

**E**  
 MAIN SECTION  
 (Page 25)

R-CH is omitted due to same as L-CH.  
**Signal Path**  
 - Tuner  
 - Tape Play  
 - Record



5-4. BLOCK DIAGRAM — MAIN SECTION —

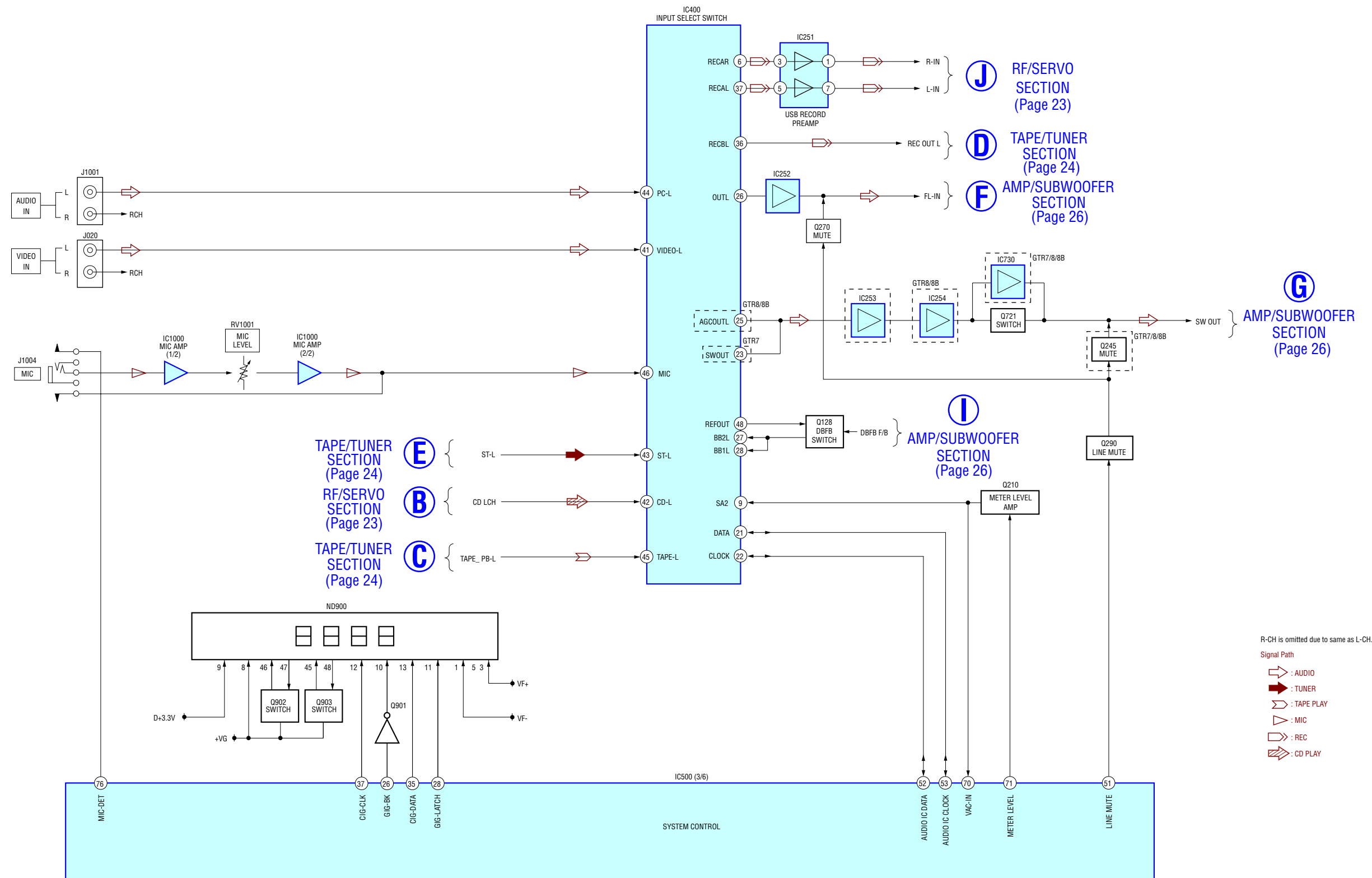

5-5. BLOCK DIAGRAM — AMP/SUBWOOFER SECTION —

**I**  
MAIN SECTION  
(Page 25)

**F**  
MAIN SECTION  
(Page 25)

**G**  
MAIN SECTION  
(Page 25)

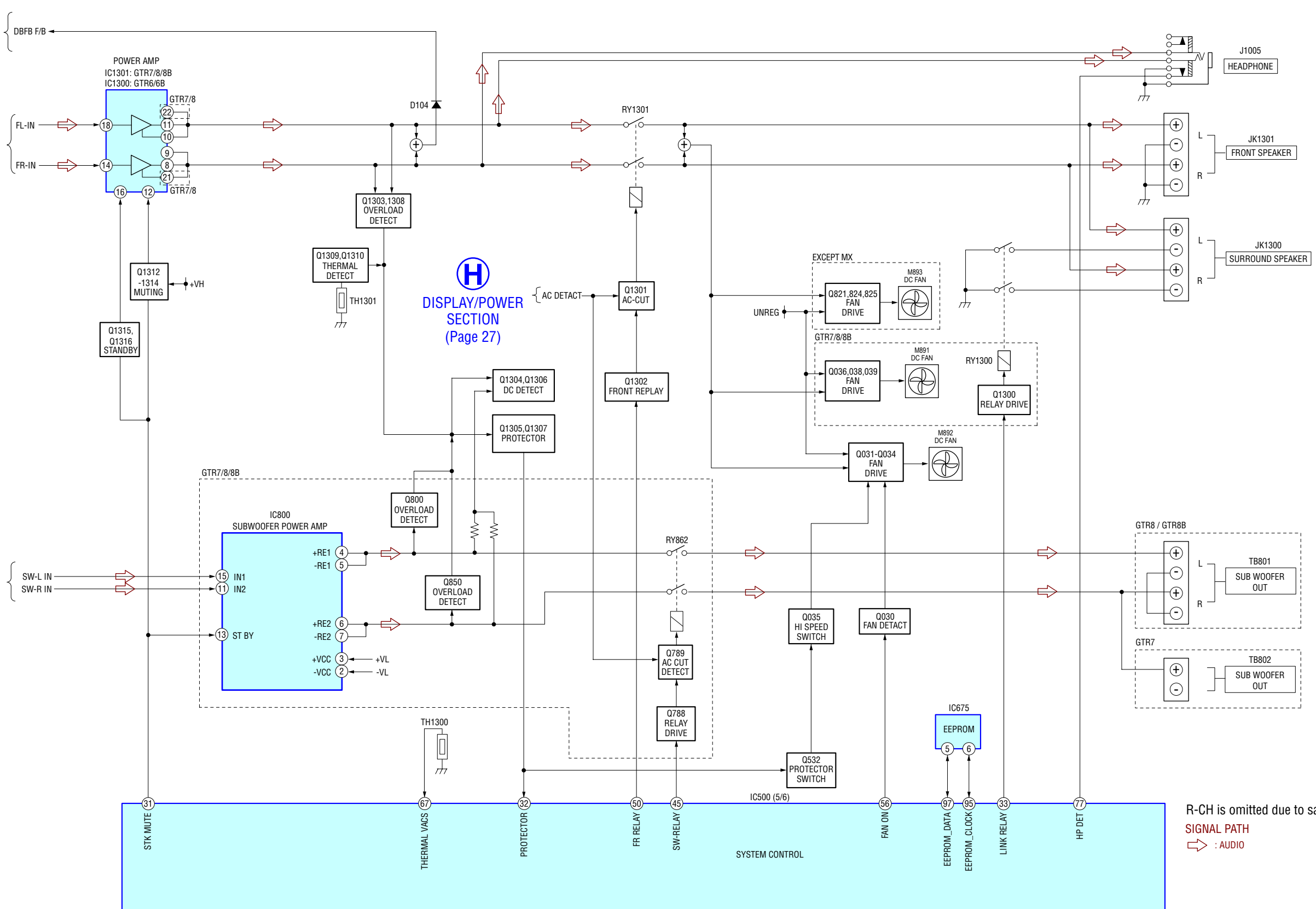

R-CH is omitted due to same as L-CH.  
 SIGNAL PATH  
 : AUDIO

5-6. BLOCK DIAGRAM — DISPLAY/POWER SECTION —

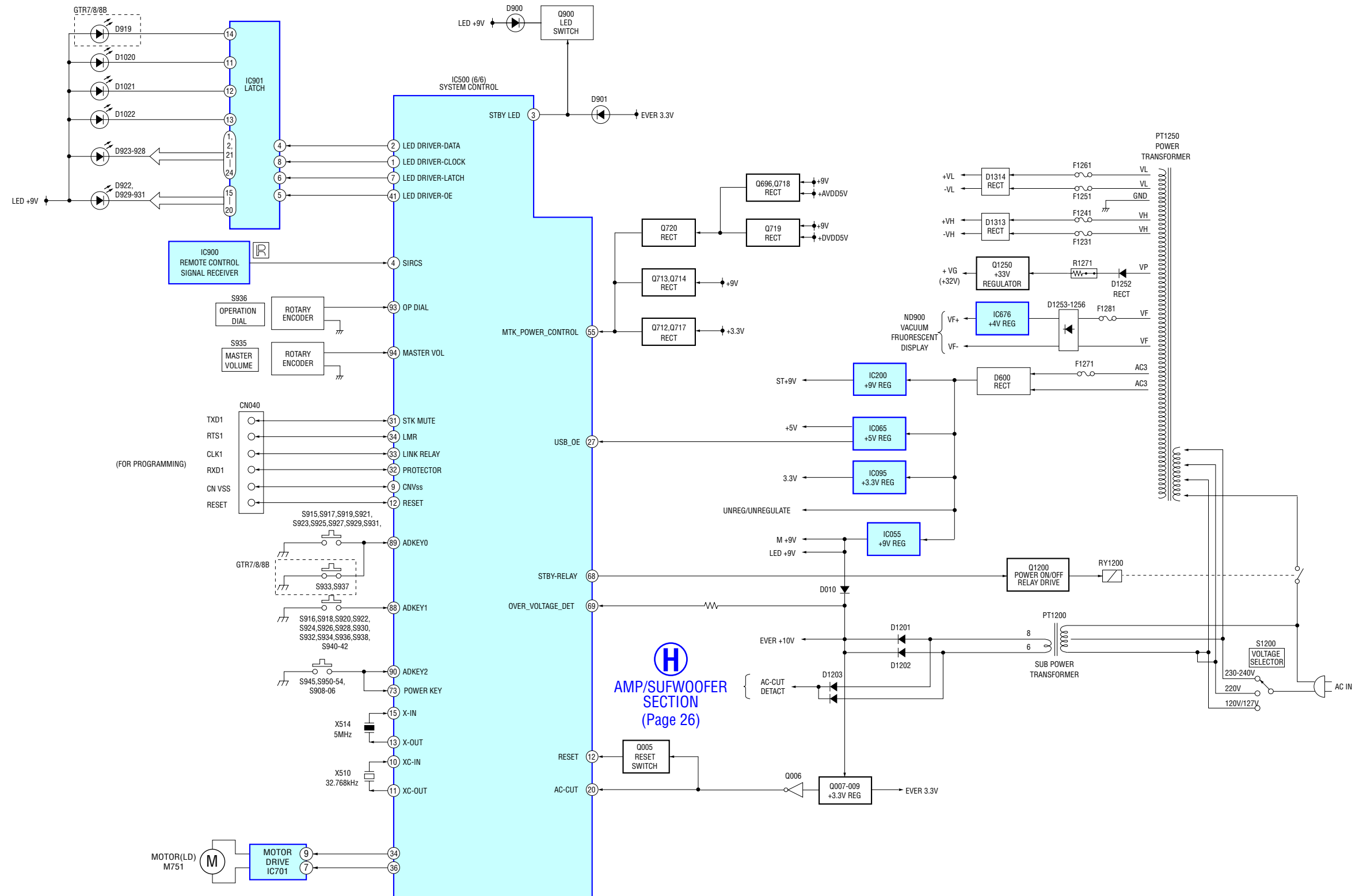

5-7. CIRCUIT BOARDS LOCATION

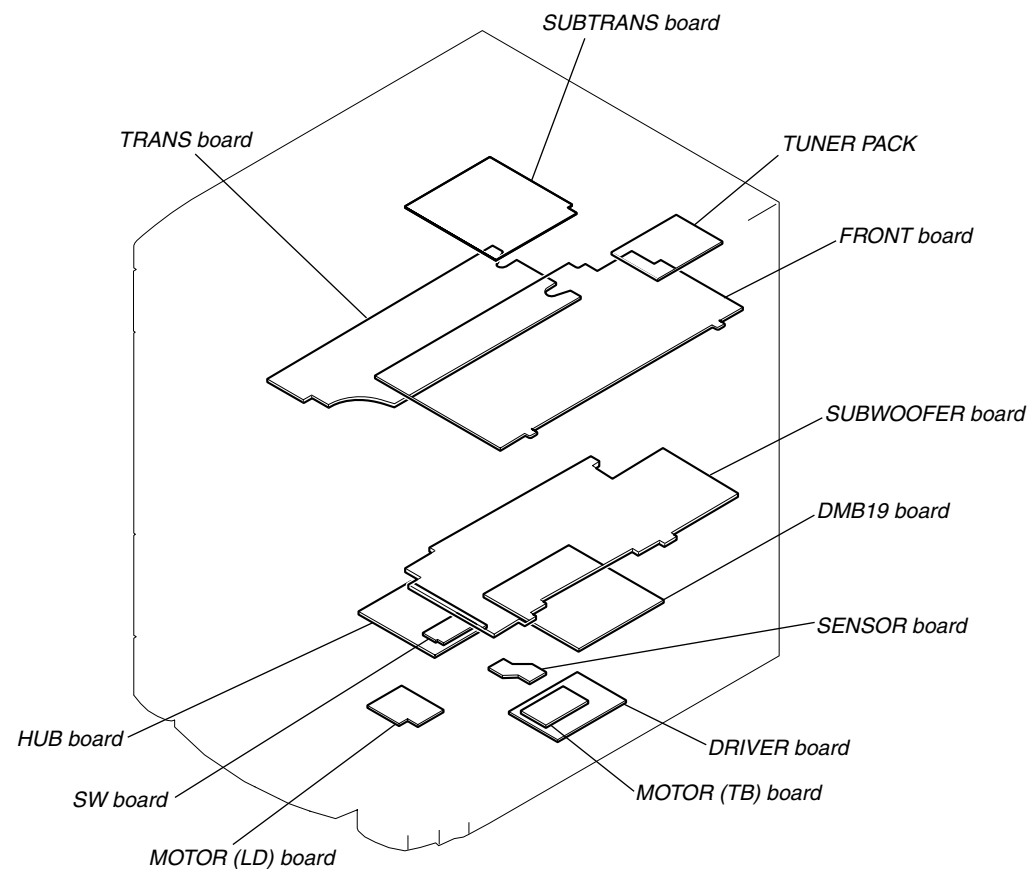
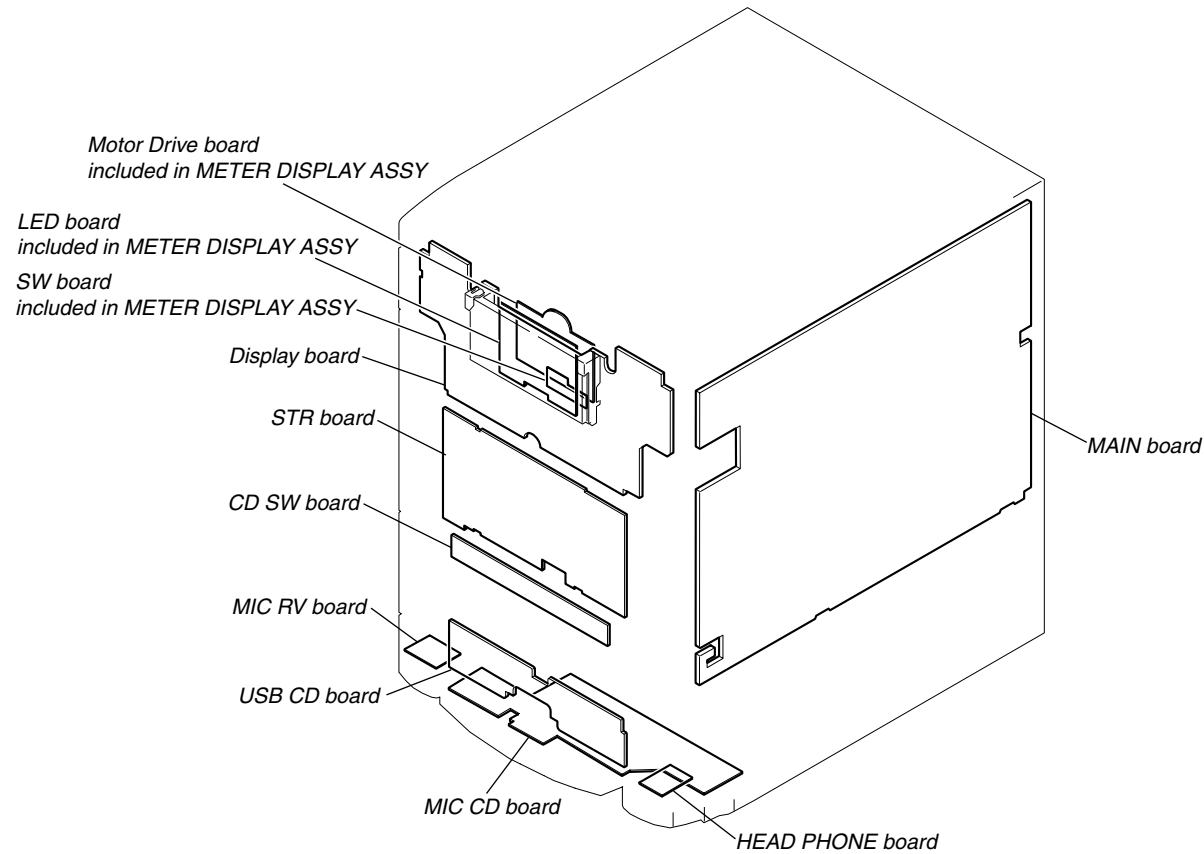

• Note For Printed Wiring Boards And Schematic Diagrams

Note on Printed Wiring Board:

- : parts extracted from the component side.
- : parts extracted from the conductor side.
- : Pattern from the side which enables seeing. (The other layer's patterns are not indicated.)

Caution:  
 Pattern face side: Parts on the pattern face side seen from the pattern face are indicated.  
 Parts face side: Parts on the parts face side seen from the parts face are indicated.

- Indication of transistor.

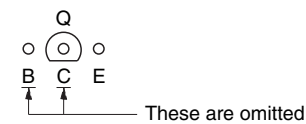
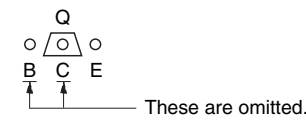
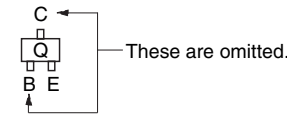

UNLEADED SOLDER

Boards requiring use of unleaded solder are printed with the lead free mark (LF) indicating the solder contains no lead. (Caution: Some printed circuit boards may not come printed with the lead free mark due to their particular size)

**LF** : LEAD FREE MARK

Unleaded solder has the following characteristics.

- Unleaded solder melts at a temperature about 40 °C higher than ordinary solder. Ordinary soldering irons can be used but the iron tip has to be applied to the solder joint for a slightly longer time. Soldering irons using a temperature regulator should be set to about 350 °C.
- Caution: The printed pattern (copper foil) may peel away if the heated tip is applied for too long, so be careful!

- Strong viscosity  
Unleaded solder is more viscous (sticky, less prone to flow) than ordinary solder so use caution not to let solder bridges occur such as on IC pins, etc.
- Usable with ordinary solder  
It is best to use only unleaded solder but unleaded solder may also be added to ordinary solder.

- Abbreviation  
MX : Mexican model

Note on Schematic Diagram:

- All capacitors are in  $\mu\text{F}$  unless otherwise noted. (p: pF) 50 WV or less are not indicated except for electrolytics and tantalums.
- All resistors are in  $\Omega$  and  $1/4\text{W}$  or less unless otherwise specified.
- : nonflammable resistor.
- : panel designation.

Note: The components identified by mark  $\Delta$  or dotted line with mark  $\Delta$  are critical for safety. Replace only with part number specified.

- : B+ Line.
- : B- Line.
- Voltage and waveforms are dc with respect to ground under no-signal (detuned) conditions.
- BD93 and Driver sections.  
no mark : CD PLAY
- Except BD93 and Driver sections.  
no mark : FM  
( ) : CD PLAY  
< > : TAPE PLAY  
[ ] : TAPE REC  
\* : Impossible to measure
- Voltages are taken with a VOM (Input impedance 10 M $\Omega$ ). Voltage variations may be noted due to normal production tolerances.
- Waveforms are taken with a oscilloscope. Voltage variations may be noted due to normal production tolerances.
- Circled numbers refer to waveforms.
- Signal path.  
 : AUDIO  
 : TUNER  
 : TAPE PLAY  
 : TAPE REC  
 : MIC  
 : CD PLAY  
 : DIGITAL  
 : USB
- Abbreviation  
E2 : 120V AC area in E model  
E3 : 240V AC area in E model  
E51 : Chilean and Peruvian model  
AR : Argentina model  
AUS : Australian model  
MX : Mexican model

• Waveforms

— DMB19 BOARD — (CD PLAY)

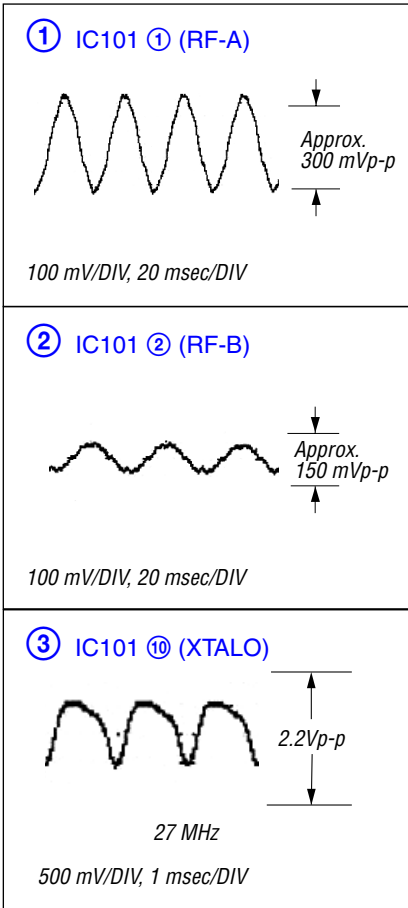

— MAIN BOARD —

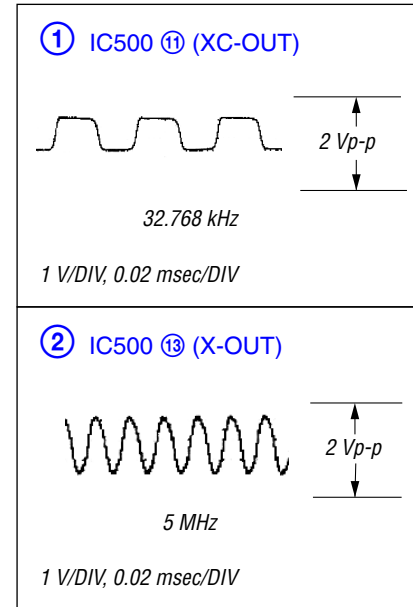

5-8. PRINTED WIRING BOARD — DISPLAY BOARD — • Refer to page 28 for Circuit Boards Location.  : Uses unleaded solder.

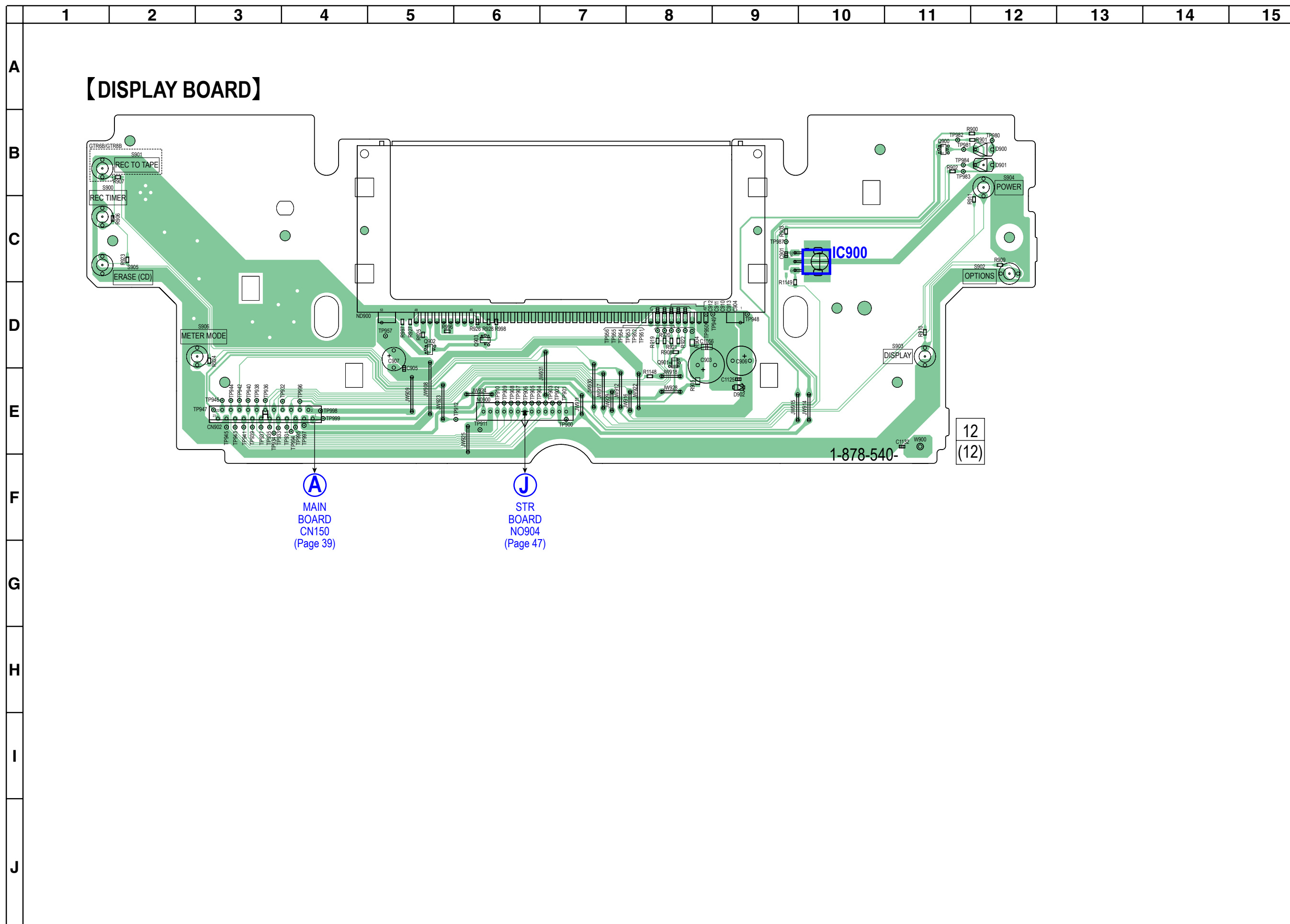



5-10. PRINTED WIRING BOARDS — DMB19 BOARD — • Refer to page 28 for Circuit Boards Location.  : Uses unleaded solder.

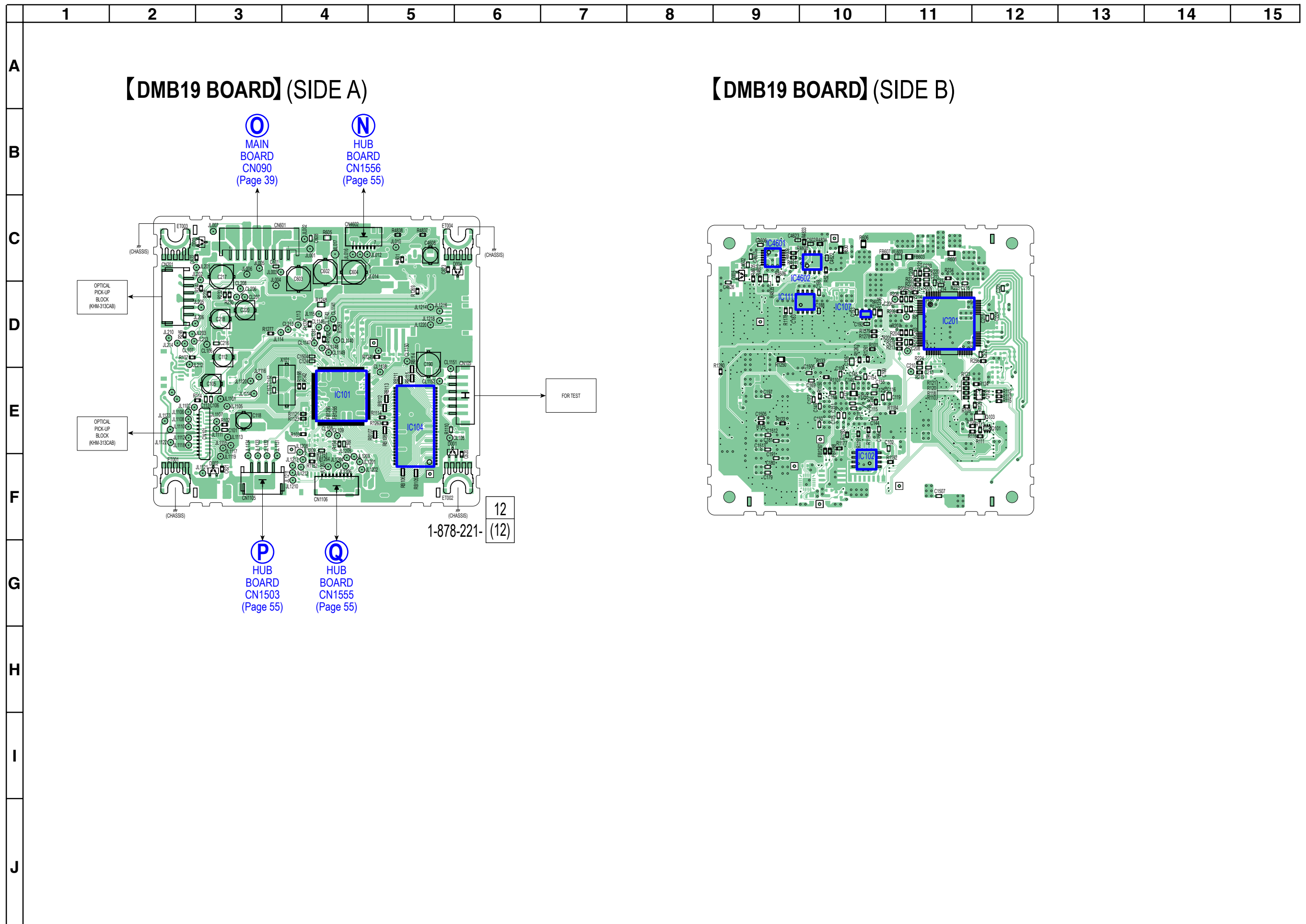



5-11. SCHEMATIC DIAGRAM — DMB19 BOARD (1/4) — • Refer to page 59 for IC Block Diagrams.

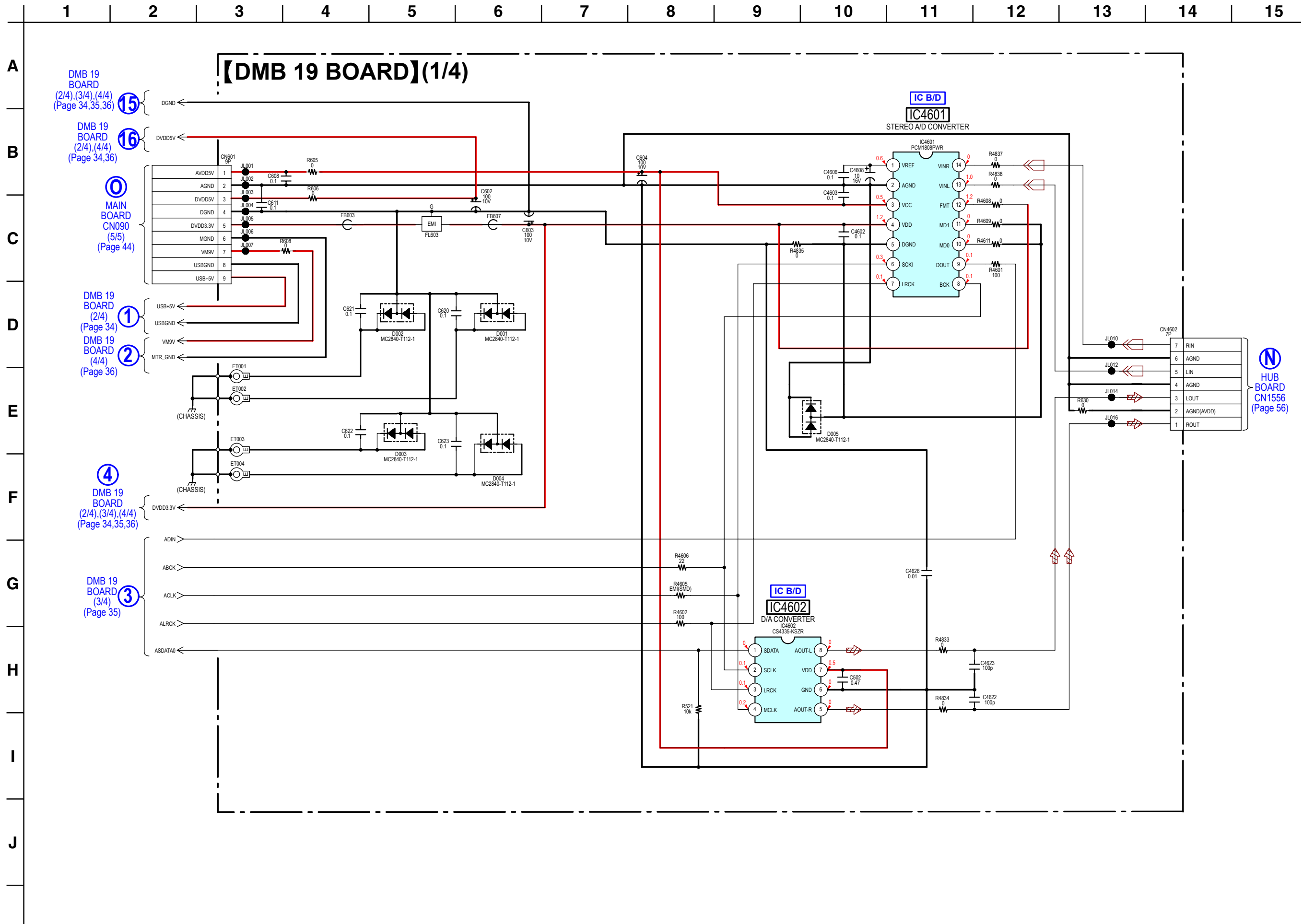

5-12. SCHEMATIC DIAGRAM — DMB19 BOARD (2/4) — • Refer to page 59 for IC Block Diagrams.

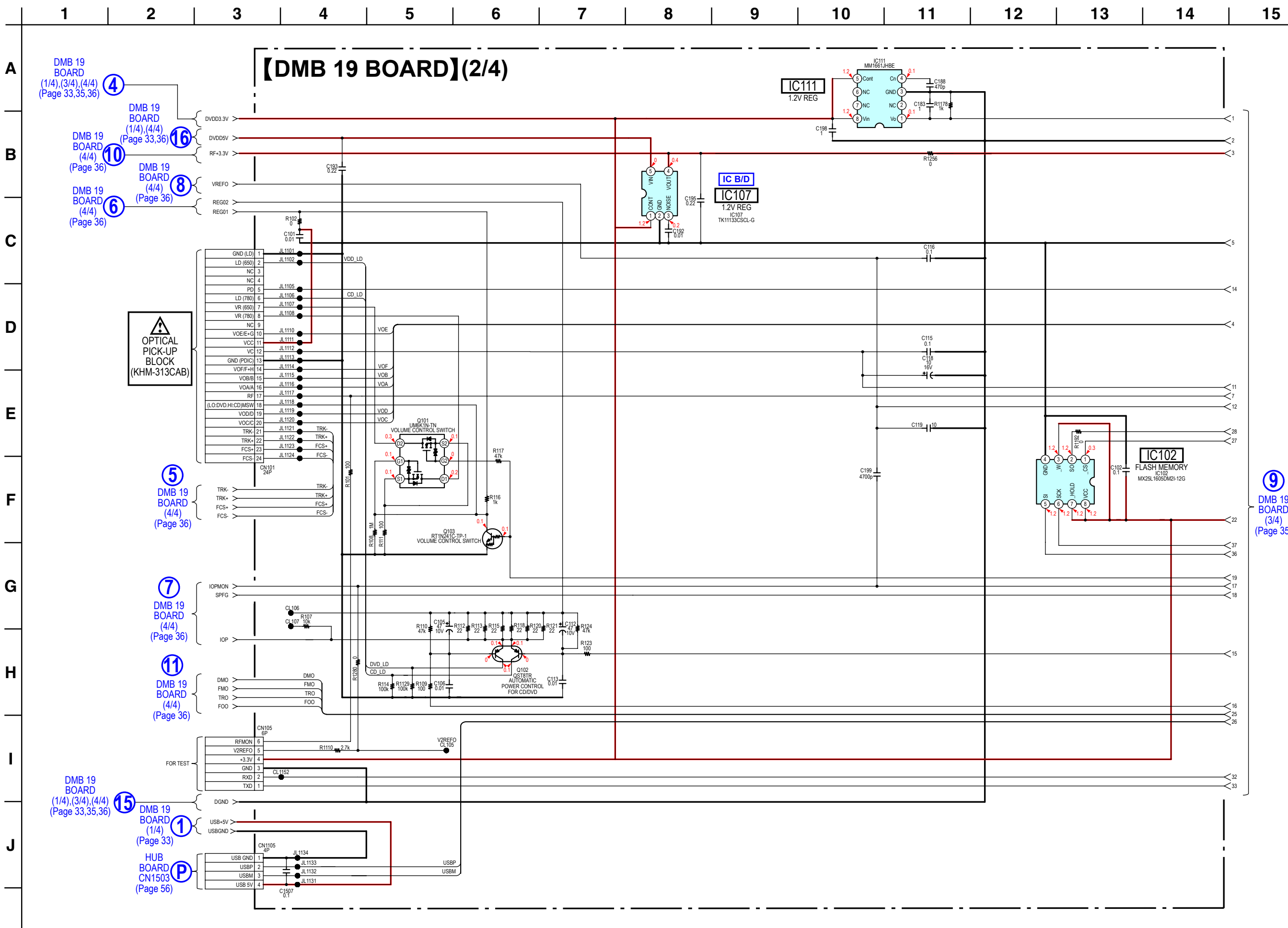



5-14. SCHEMATIC DIAGRAM — DMB19 BOARD (4/4) — • Refer to page 59 for IC Block Diagrams.

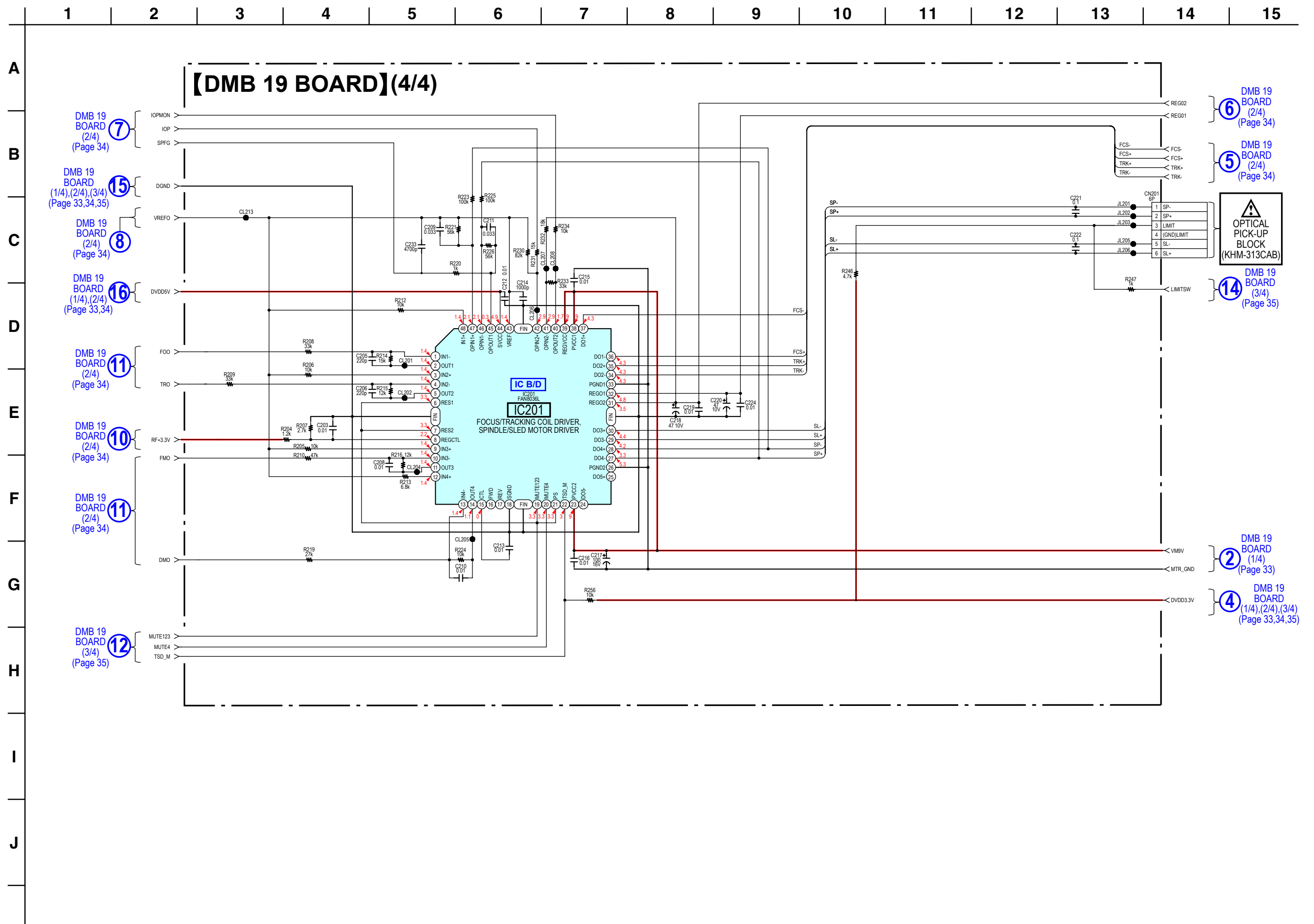

5-15. PRINTED WIRING BOARD — FRONT BOARD — • Refer to page 28 for Circuit Boards Location.  : Uses unleaded solder.

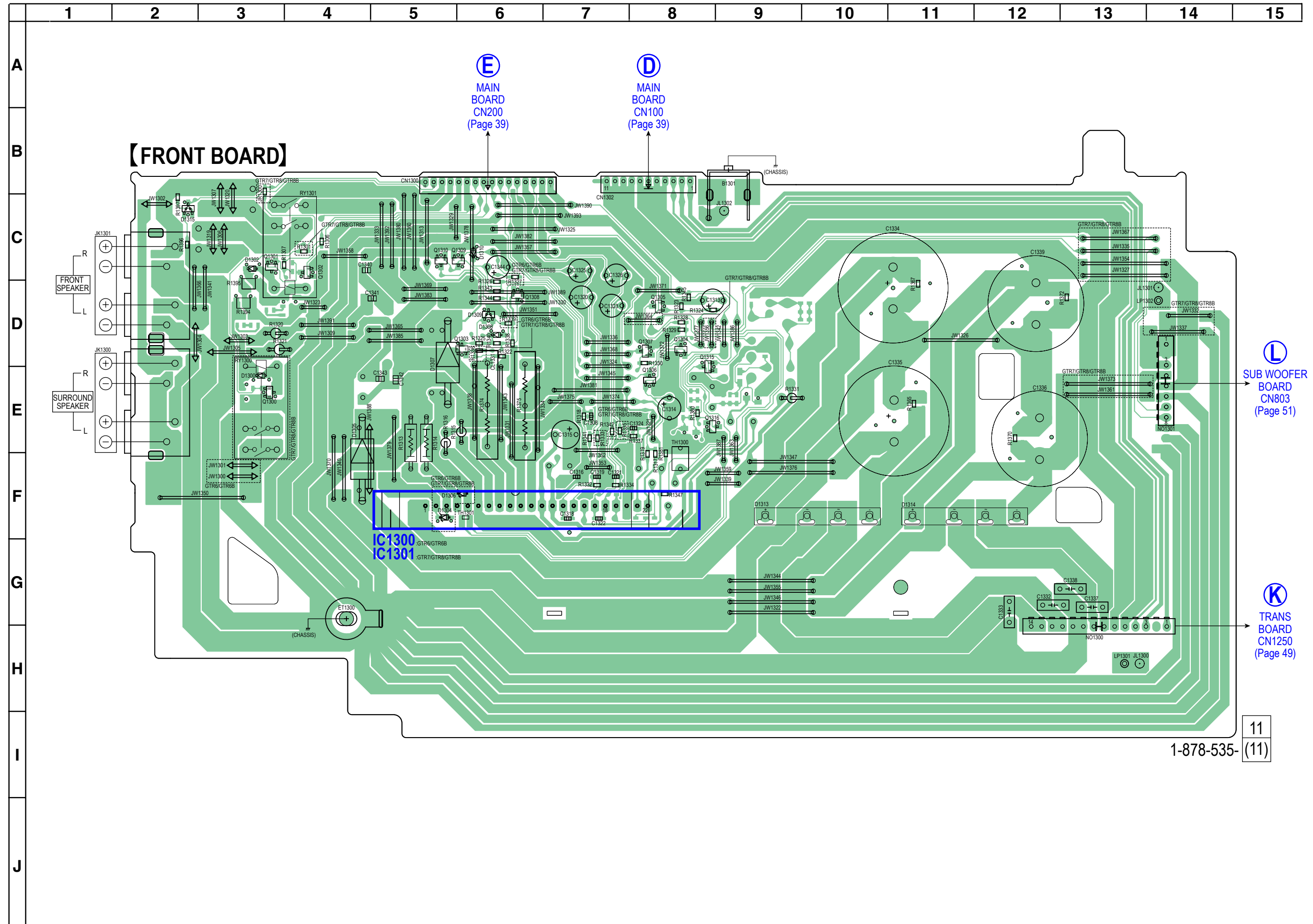





5-18. SCHEMATIC DIAGRAM — MAIN BOARD (1/5) — • Refer to page 22 for Block Diagrams. • Refer to page 29 for Waveforms. • Refer to page 59 for IC Block Diagrams.

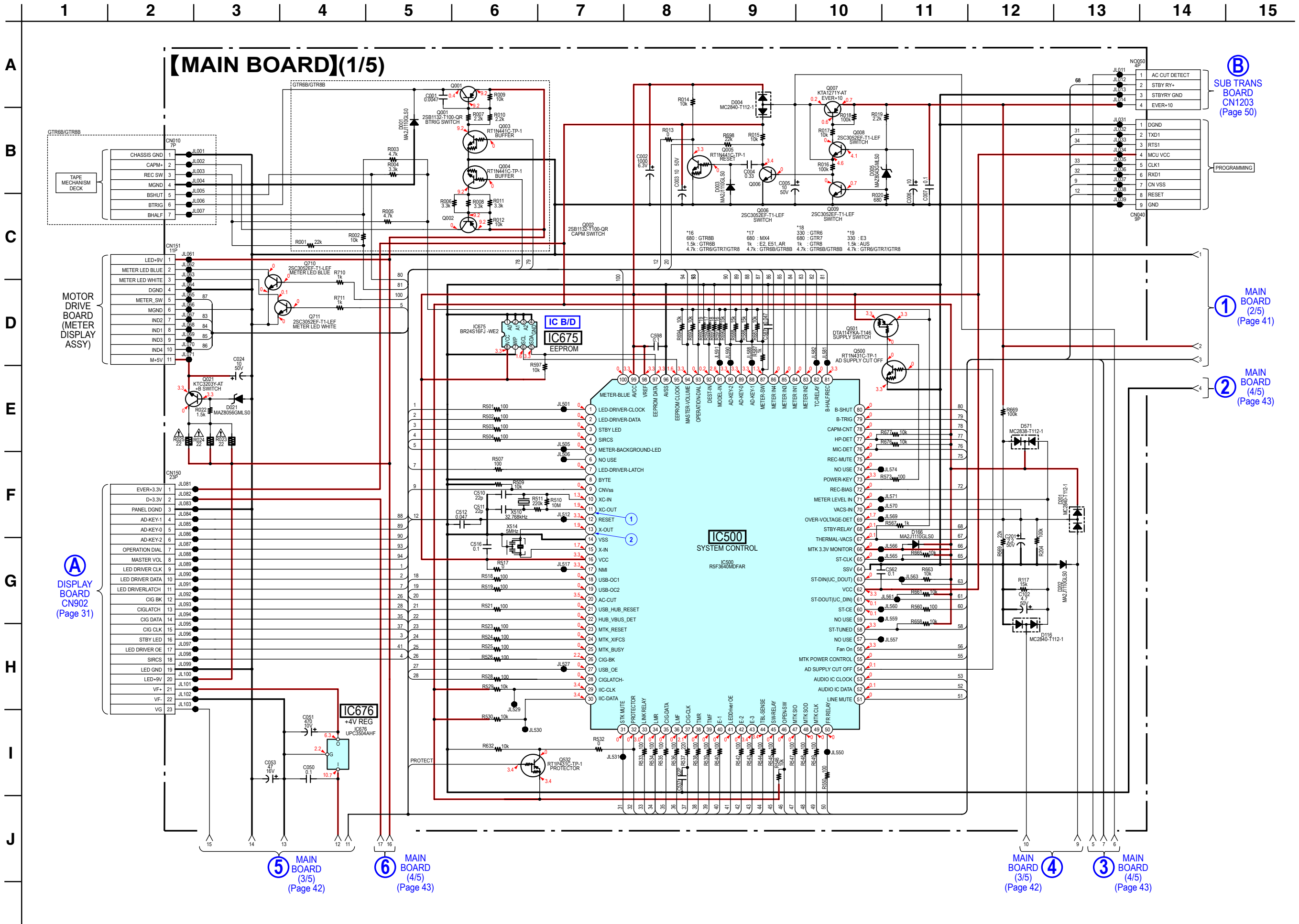



5-19. SCHEMATIC DIAGRAM — MAIN BOARD (2/5) — • Refer to page 22 for Block Diagrams. • Refer to page 59 for IC Block Diagrams.

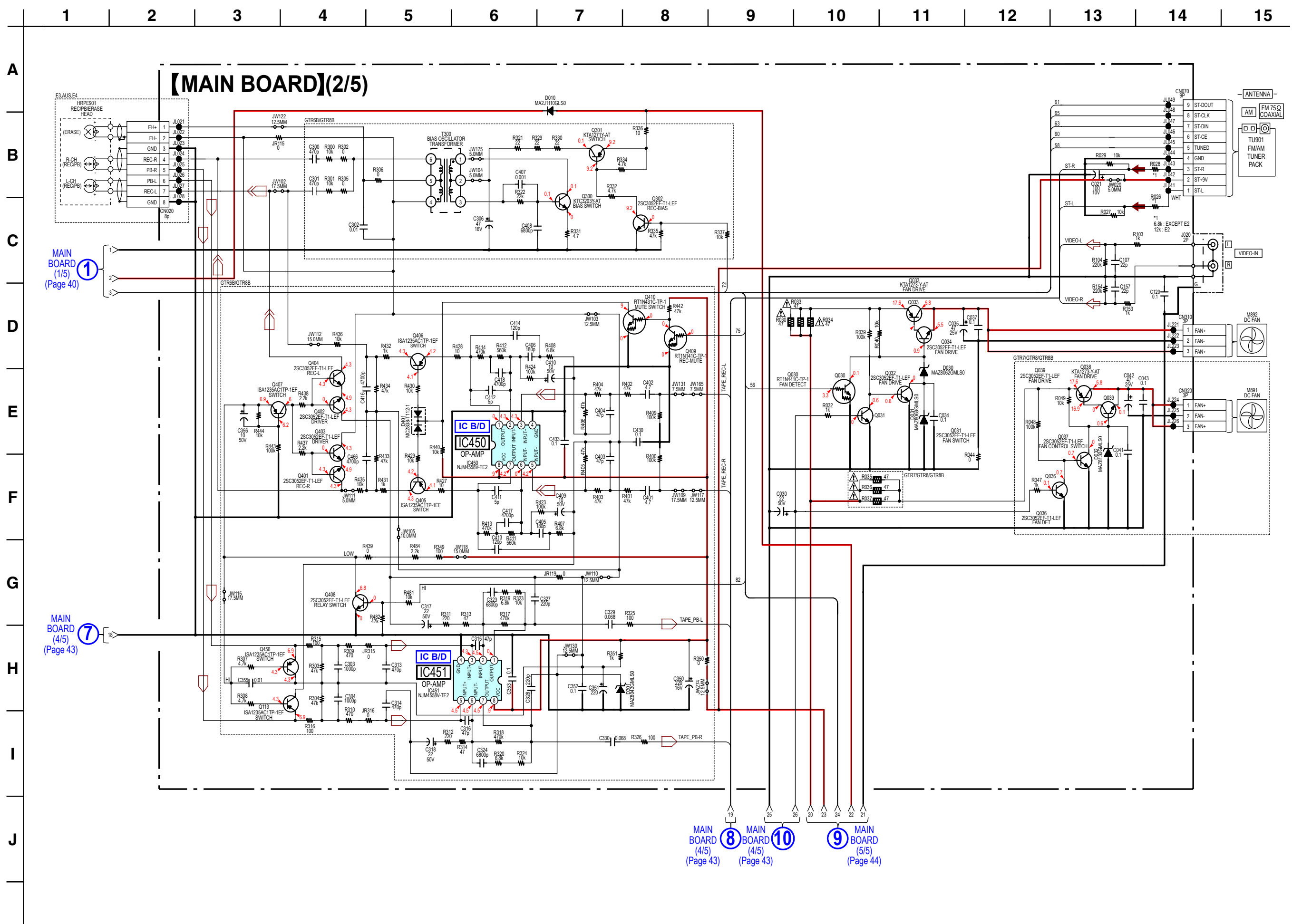

5-20. SCHEMATIC DIAGRAM — MAIN BOARD (3/5) — • Refer to page 22 for Block Diagrams. • Refer to page 59 for IC Block Diagrams.

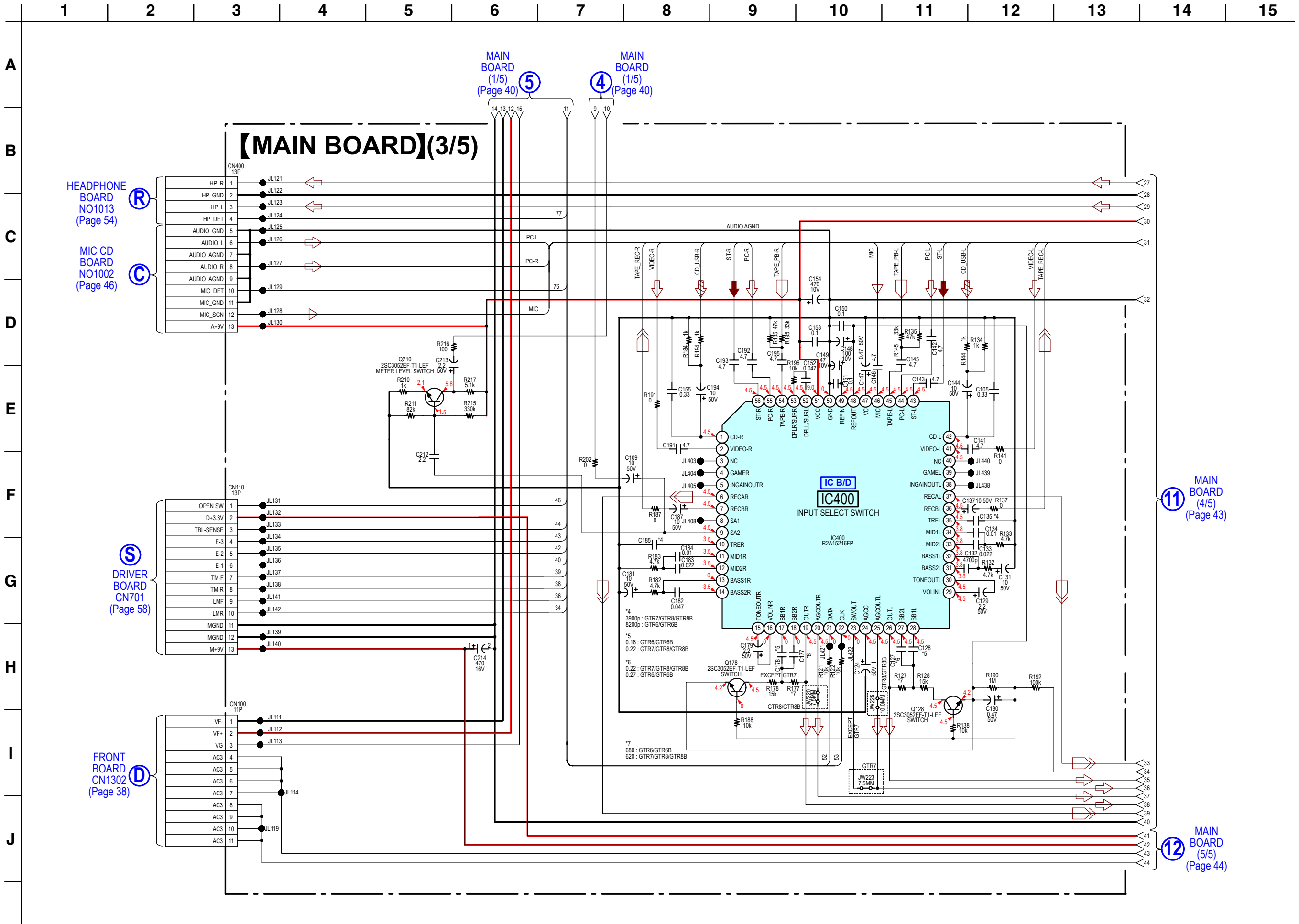



5-22. SCHEMATIC DIAGRAM — MAIN BOARD (5/5) — • Refer to page 22 for Block Diagrams.

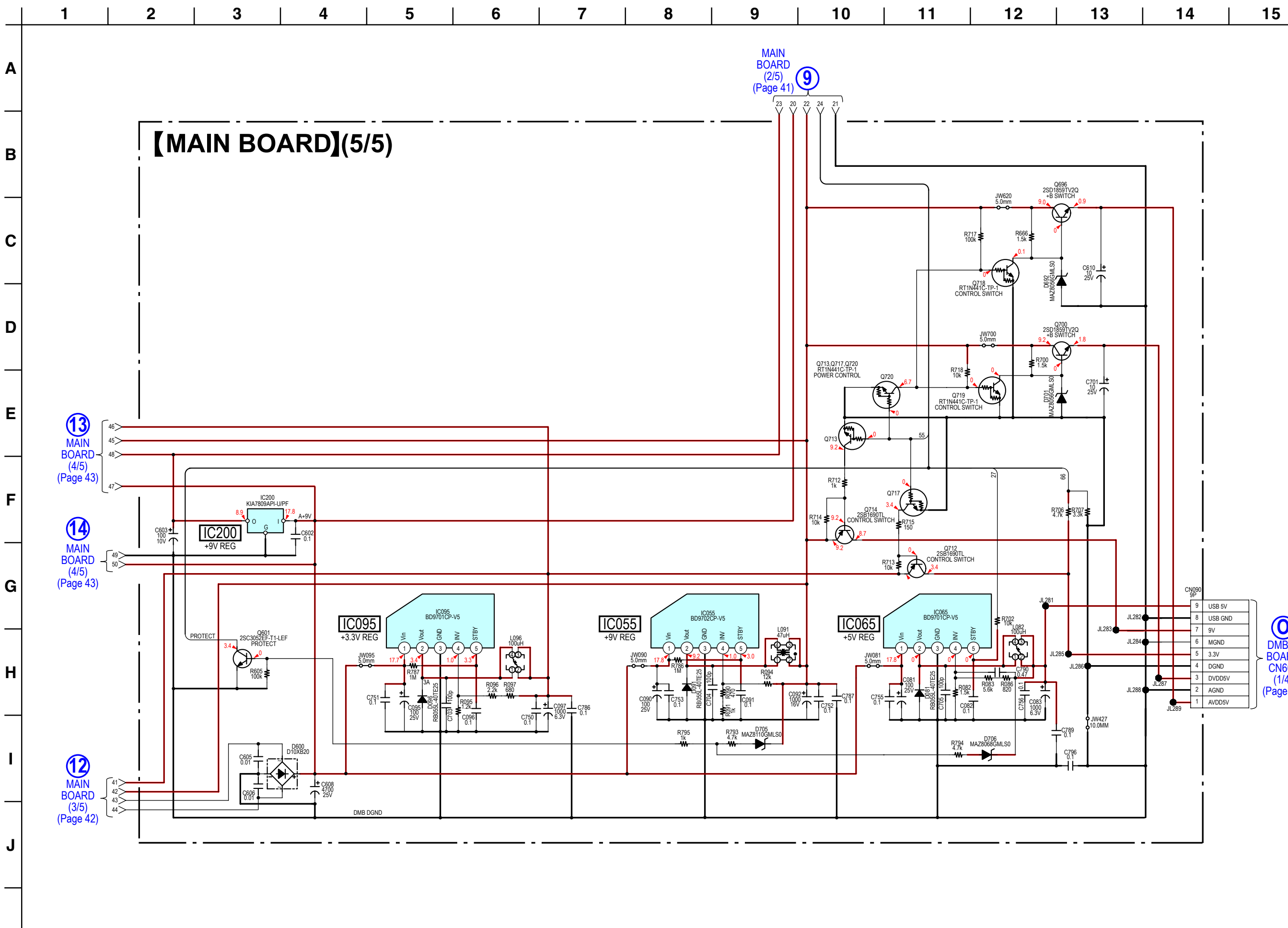

5-23. PRINTED WIRING BOARD — MIC CD AND MIC RV BOARD — • Refer to page 28 for Circuit Boards Location.  : Uses unleaded solder.

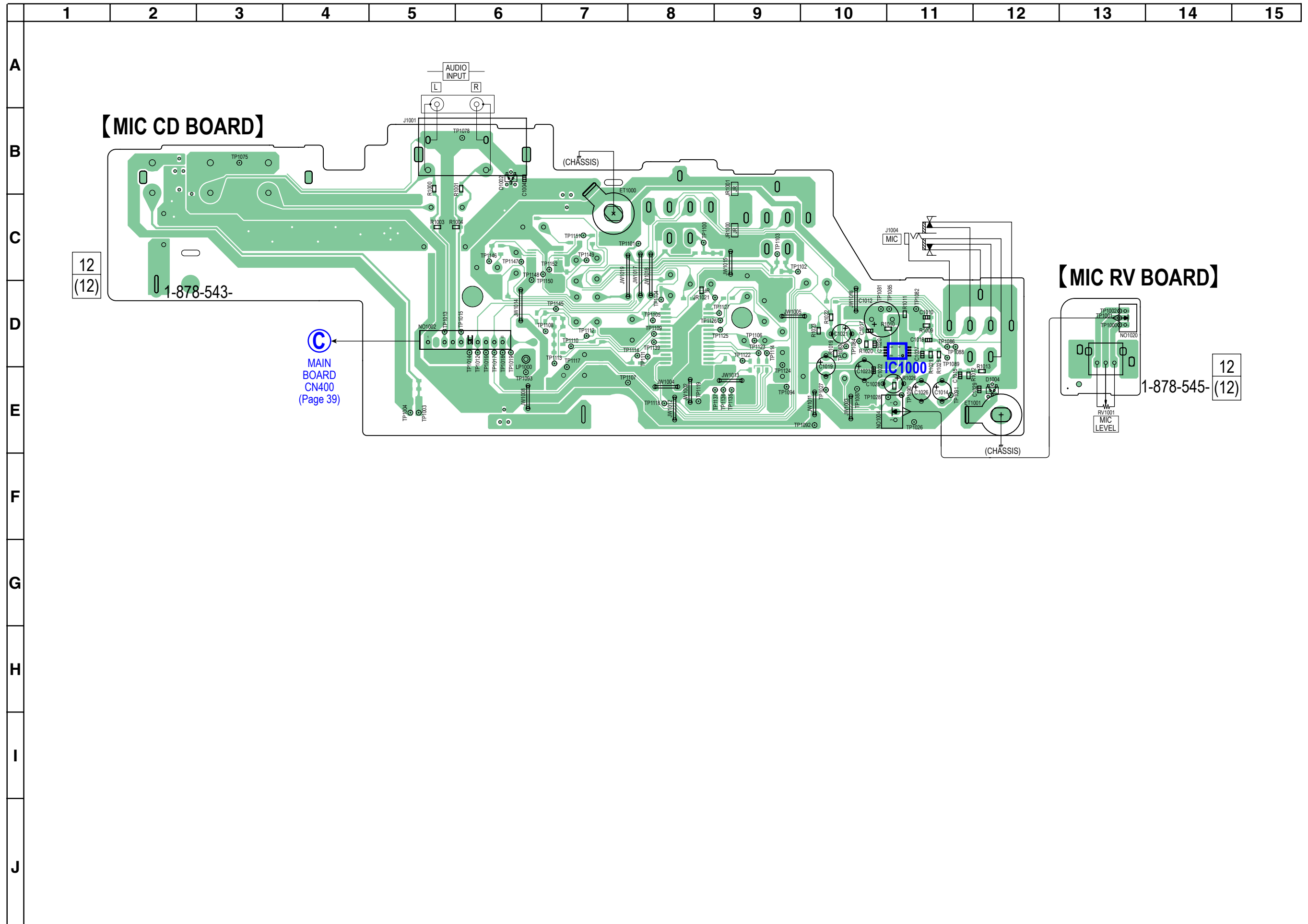

5-24. SCHEMATIC DIAGRAM — MIC CD AND MIC RV BOARD — • Refer to page 59 for IC Block Diagrams.

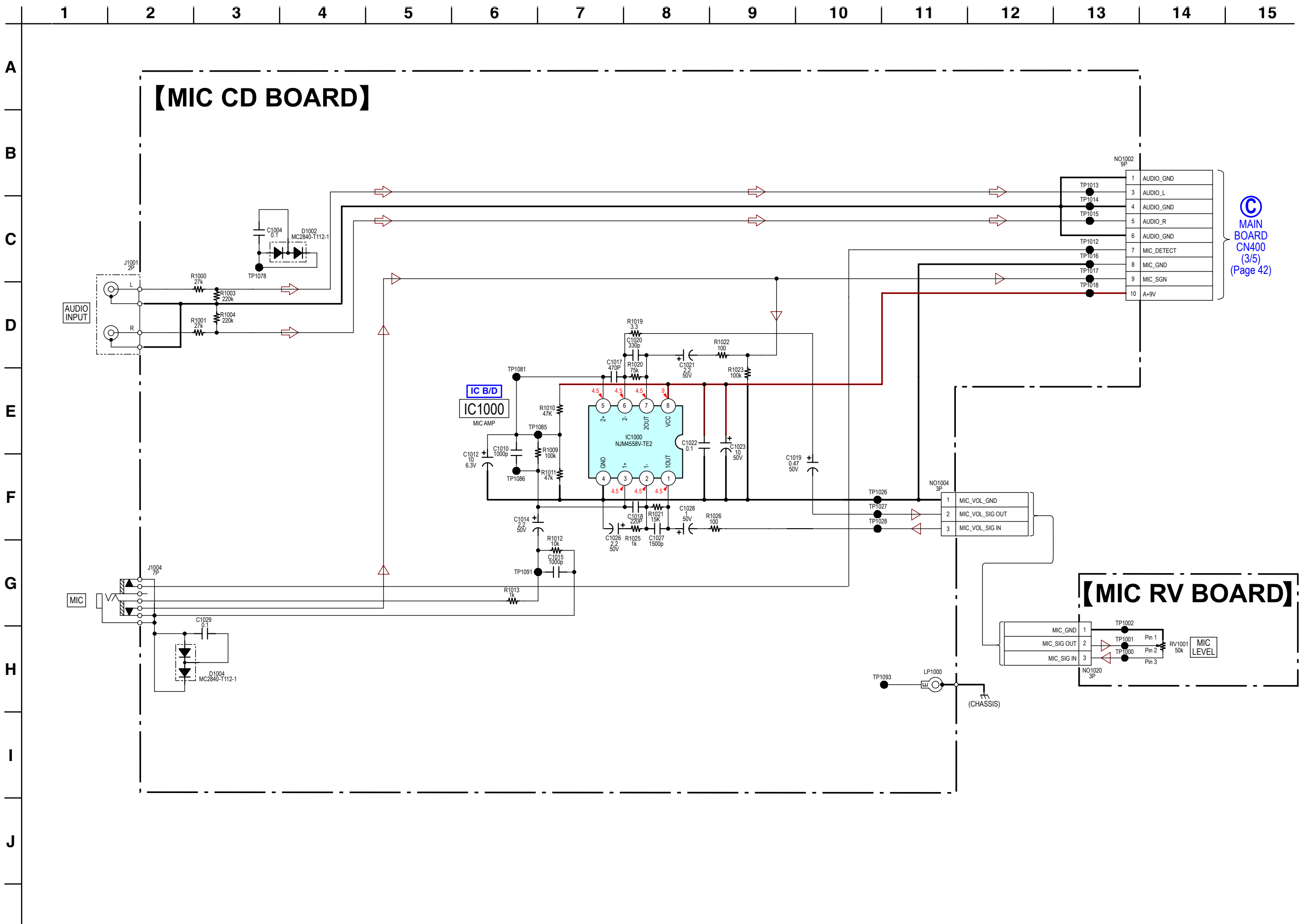

Ⓒ  
MAIN BOARD  
CN400  
(3/5)  
(Page 42)

NO1002	9P	1	AUDIO_GND
		3	AUDIO_L
		4	AUDIO_GND
		5	AUDIO_R
		6	AUDIO_GND
		7	MIC_DETECT
		8	MIC_GND
		9	MIC_SGN
		10	A+9V

NO1004	3P	1	MIC_VOL_GND
		2	MIC_VOL_SIG OUT
		3	MIC_VOL_SIG IN

NO1020	3P	1	MIC_GND
		2	MIC_SIG OUT
		3	MIC_SIG IN

5-25. PRINTED WIRING BOARD — STR AND CD\_SW BOARD — • Refer to page 28 for Circuit Boards Location.  : Uses unleaded solder.

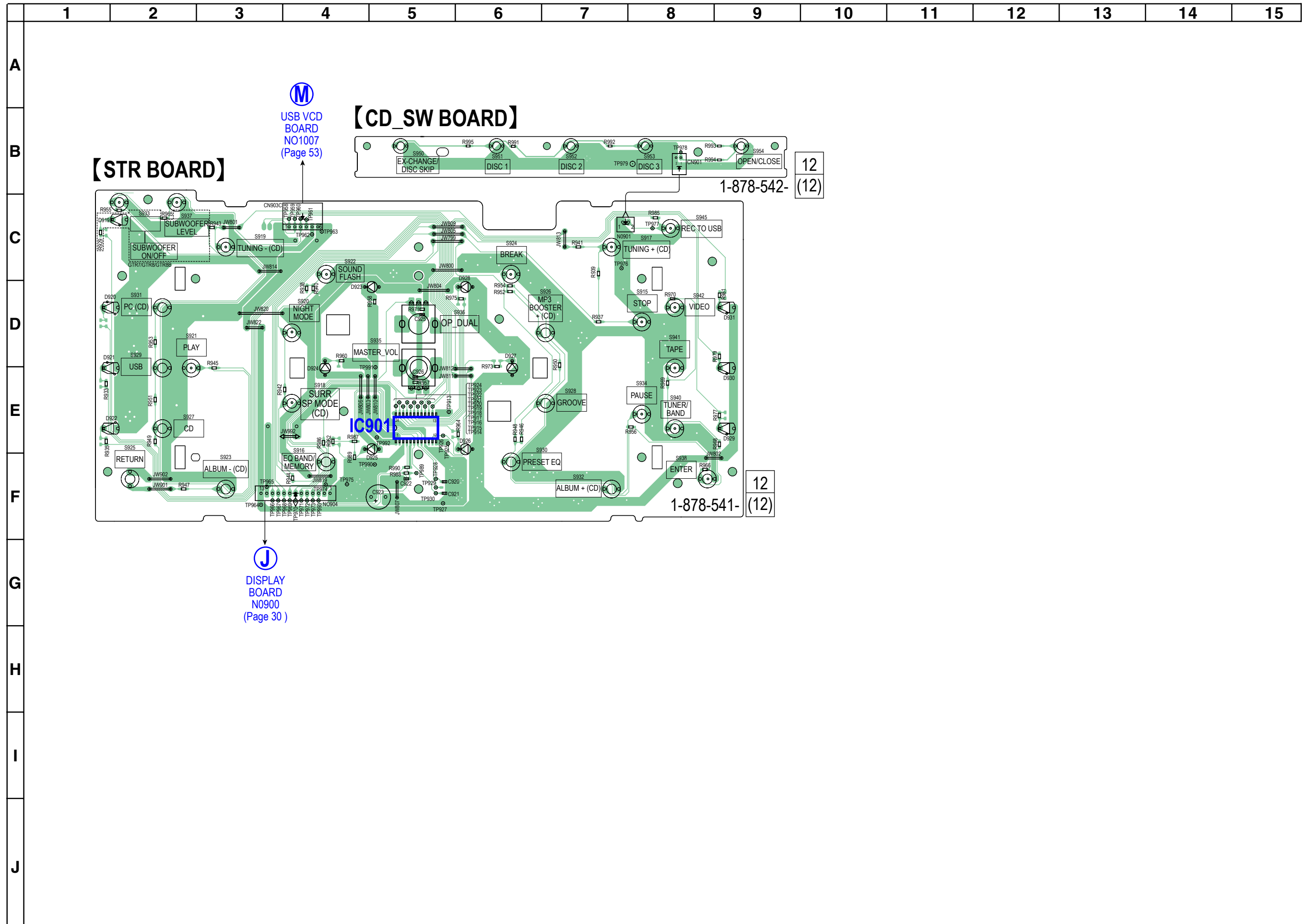

**M**  
 USB VCD  
 BOARD  
 NO1007  
 (Page 53)

**[CD\_SW BOARD]**

**[STR BOARD]**

12  
 (12)

1-878-542-

12  
 (12)

1-878-541-

**J**  
 DISPLAY  
 BOARD  
 NO900  
 (Page 30)

5-26. SCHEMATIC DIAGRAM — STR AND CD\_SW BOARD — • Refer to page 22 for Block Diagrams.

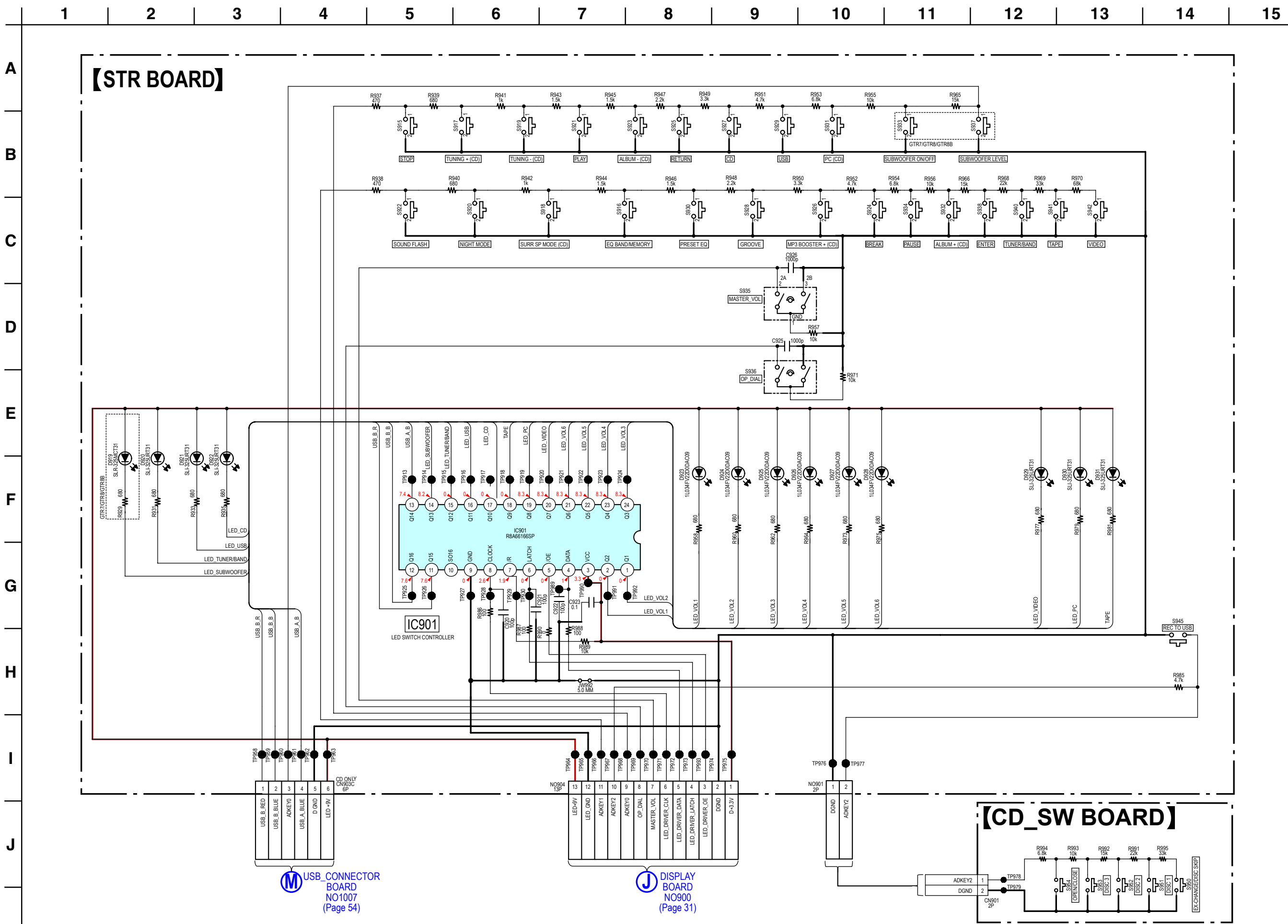



5-27. PRINTED WIRING BOARD — TRANS AND SUB TRANS BOARD — • Refer to page 28 for Circuit Boards Location.  : Uses unleaded solder.

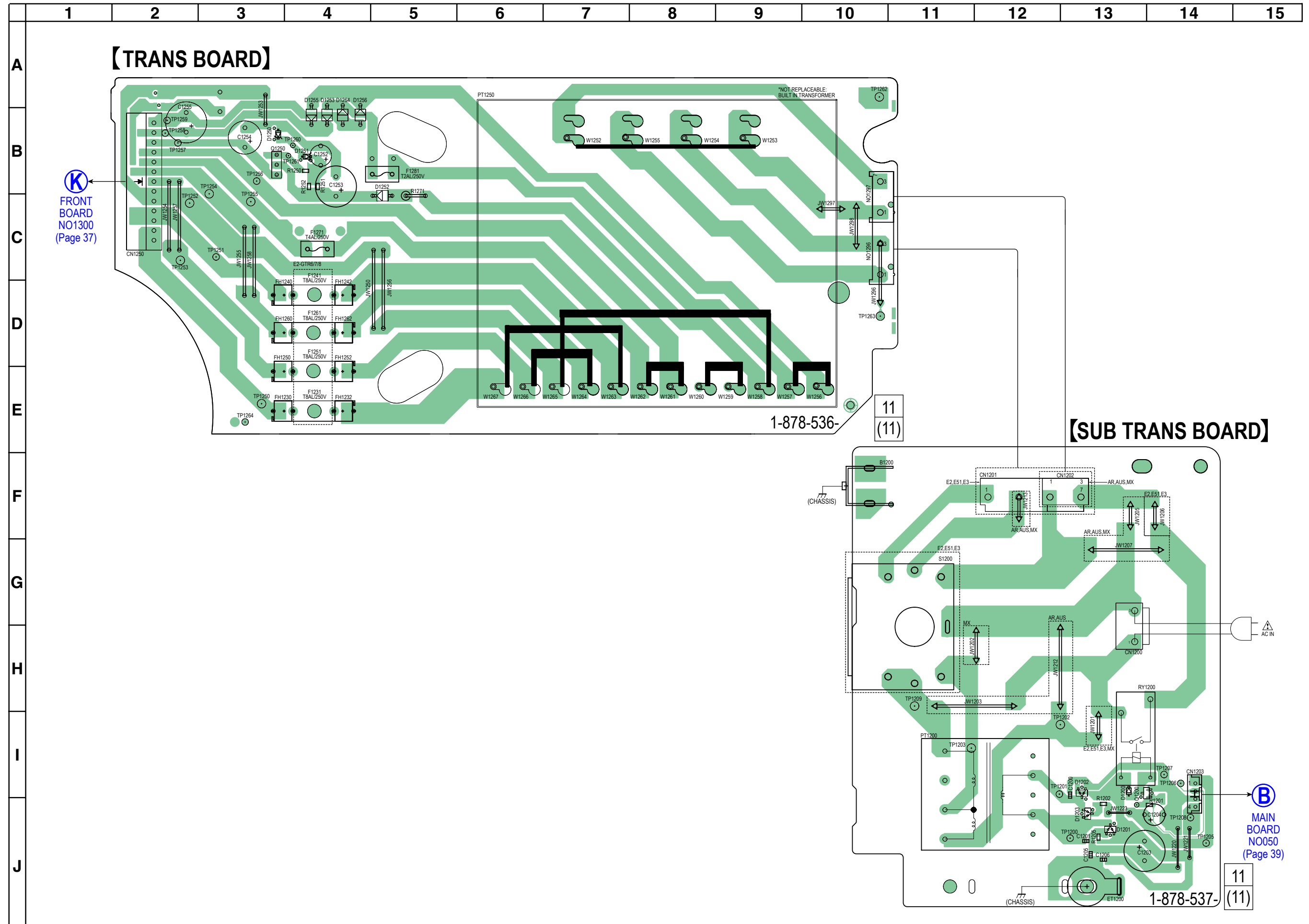

5-28. SCHEMATIC DIAGRAM — TRANS AND SUB TRANS BOARD — • Refer to page 22 for Block Diagrams.

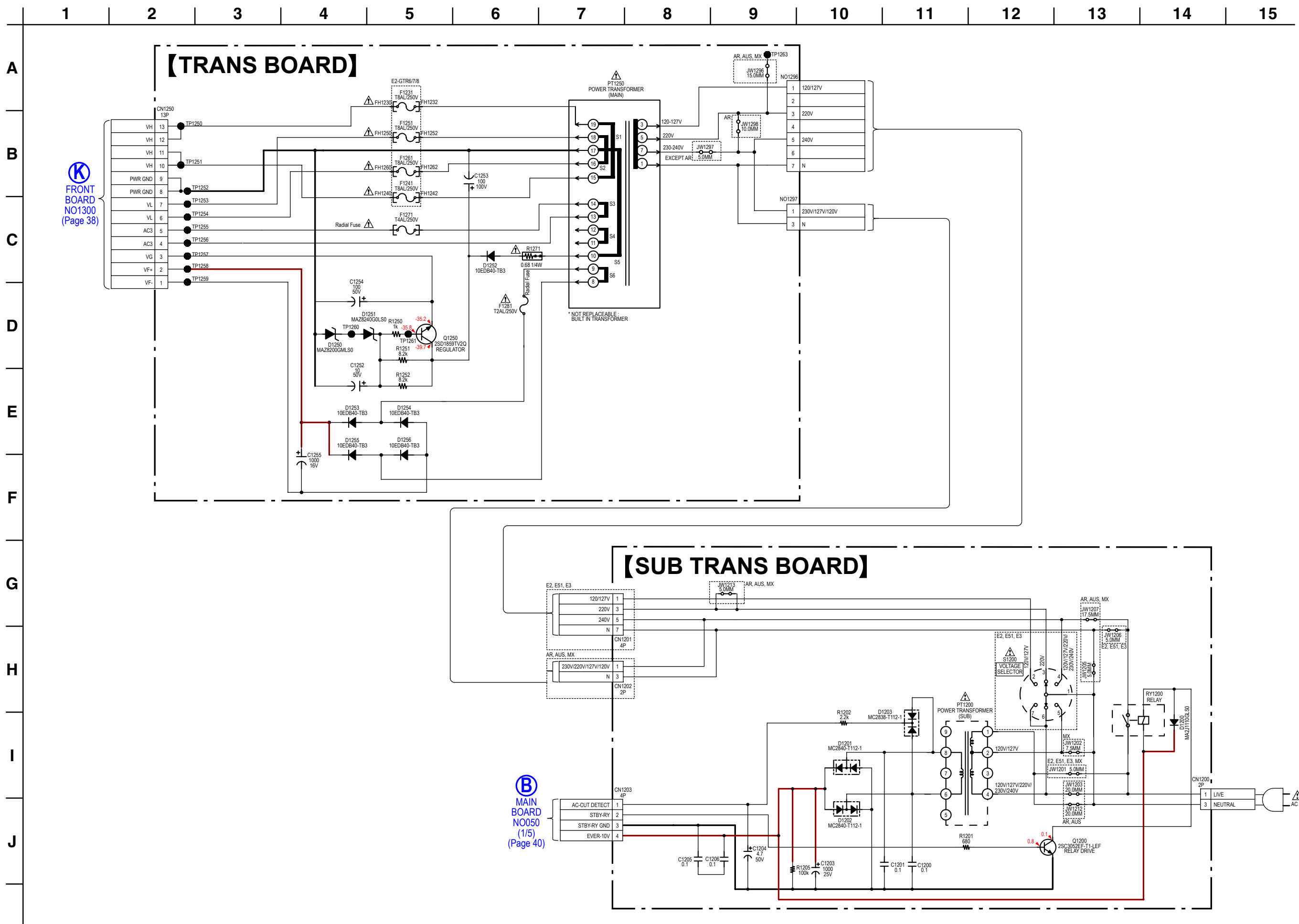

**(K)**  
FRONT BOARD  
NO1300  
(Page 38)

**(B)**  
MAIN BOARD  
NO050  
(1/5)  
(Page 40)







5-32. SCHEMATIC DIAGRAM — HEADPHONE AND USB CD BOARD —

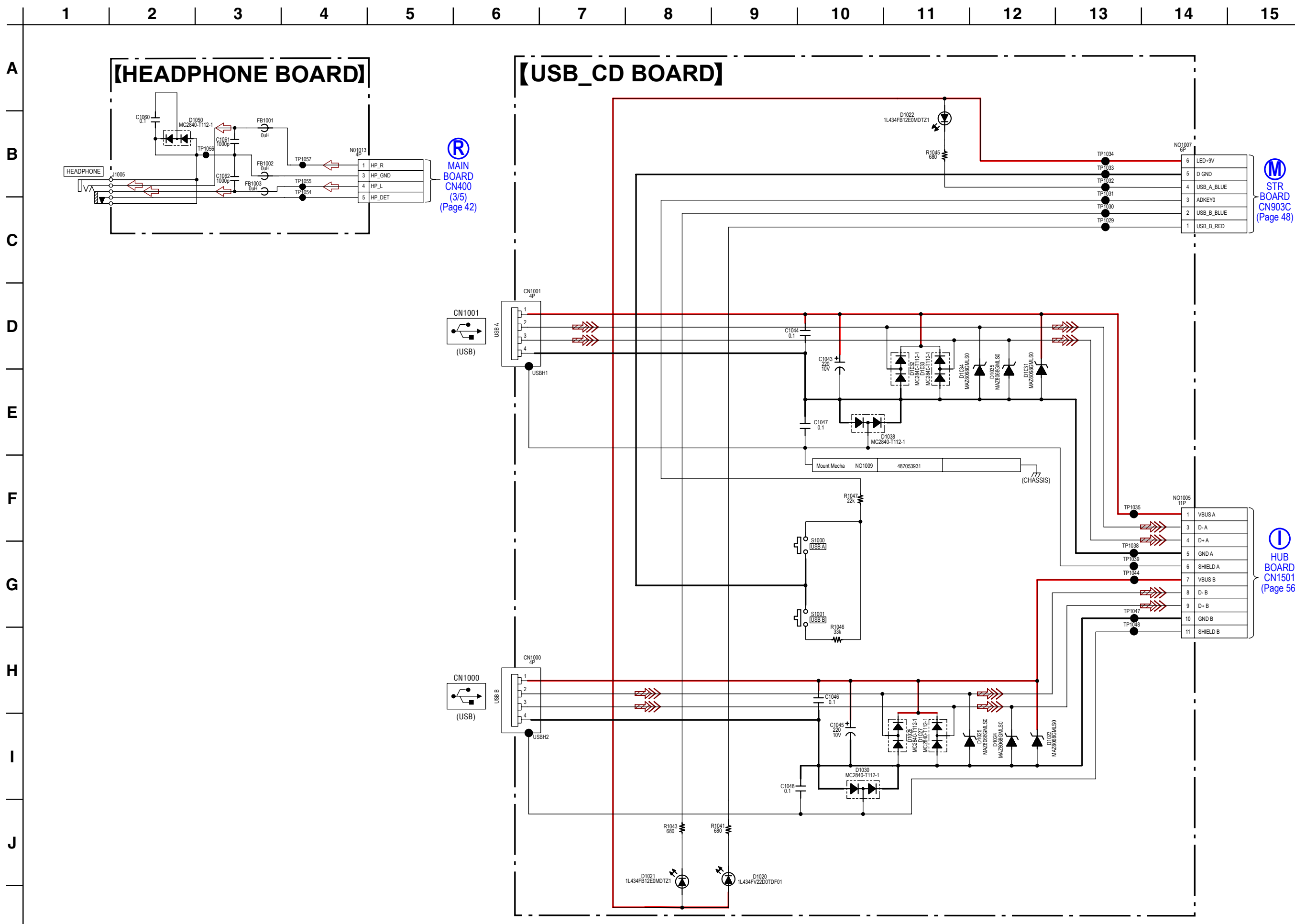

5-33. PRINTED WIRING BOARDS — HUB BOARD — • Refer to page 28 for Circuit Boards Location.

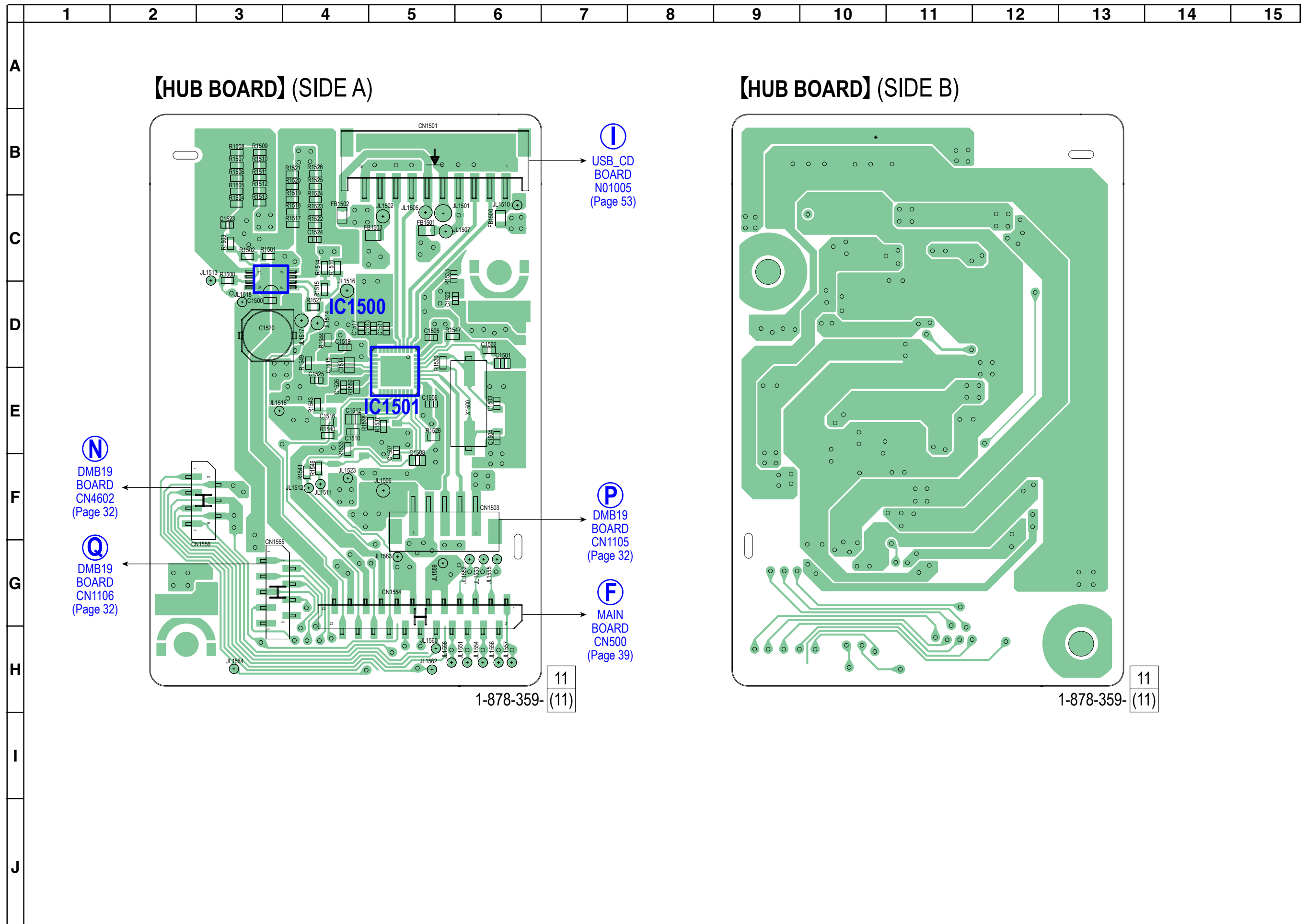

5-34. SCHEMATIC DIAGRAM — HUB BOARD — • Refer to page 22 for Block Diagrams. • Refer to page 59 for IC Block Diagrams.

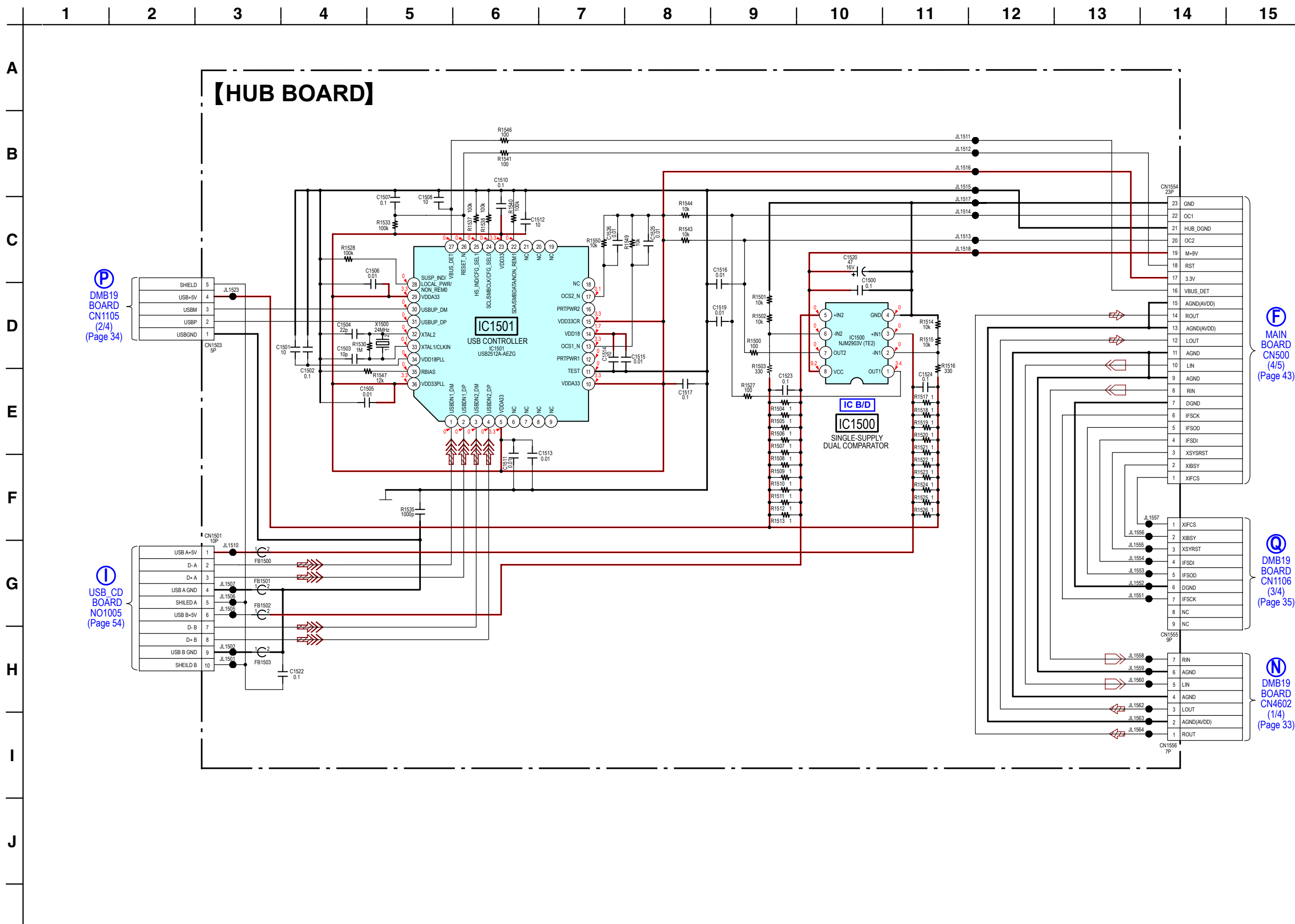



5-35. PRINTED WIRING BOARDS — DRIVE BOARD — • Refer to page 28 for Circuit Boards Location.

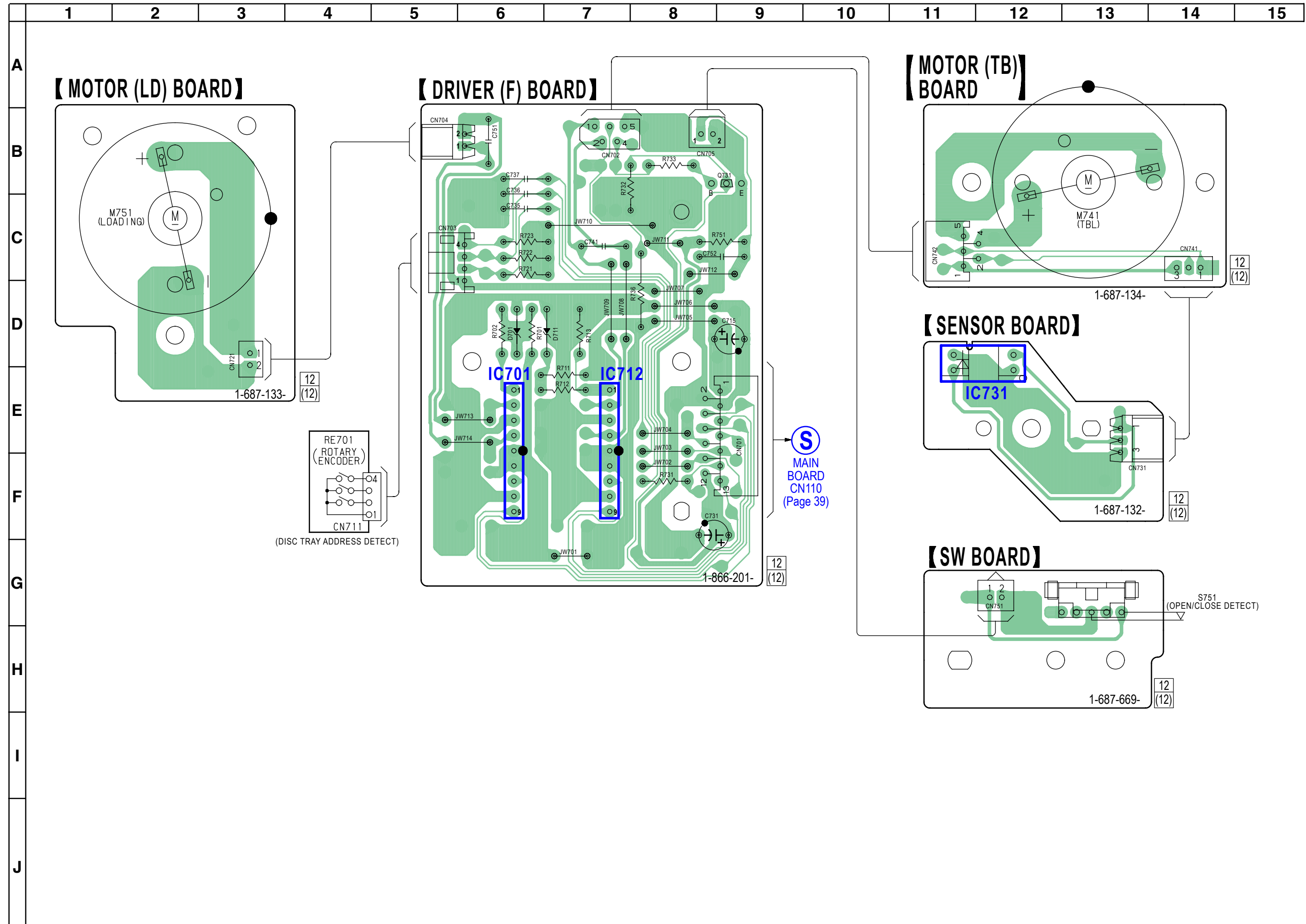

5-36. SCHEMATIC DIAGRAM — DRIVE BOARD — • Refer to page 22 for Block Diagrams. • Refer to page 59 for IC Block Diagrams.

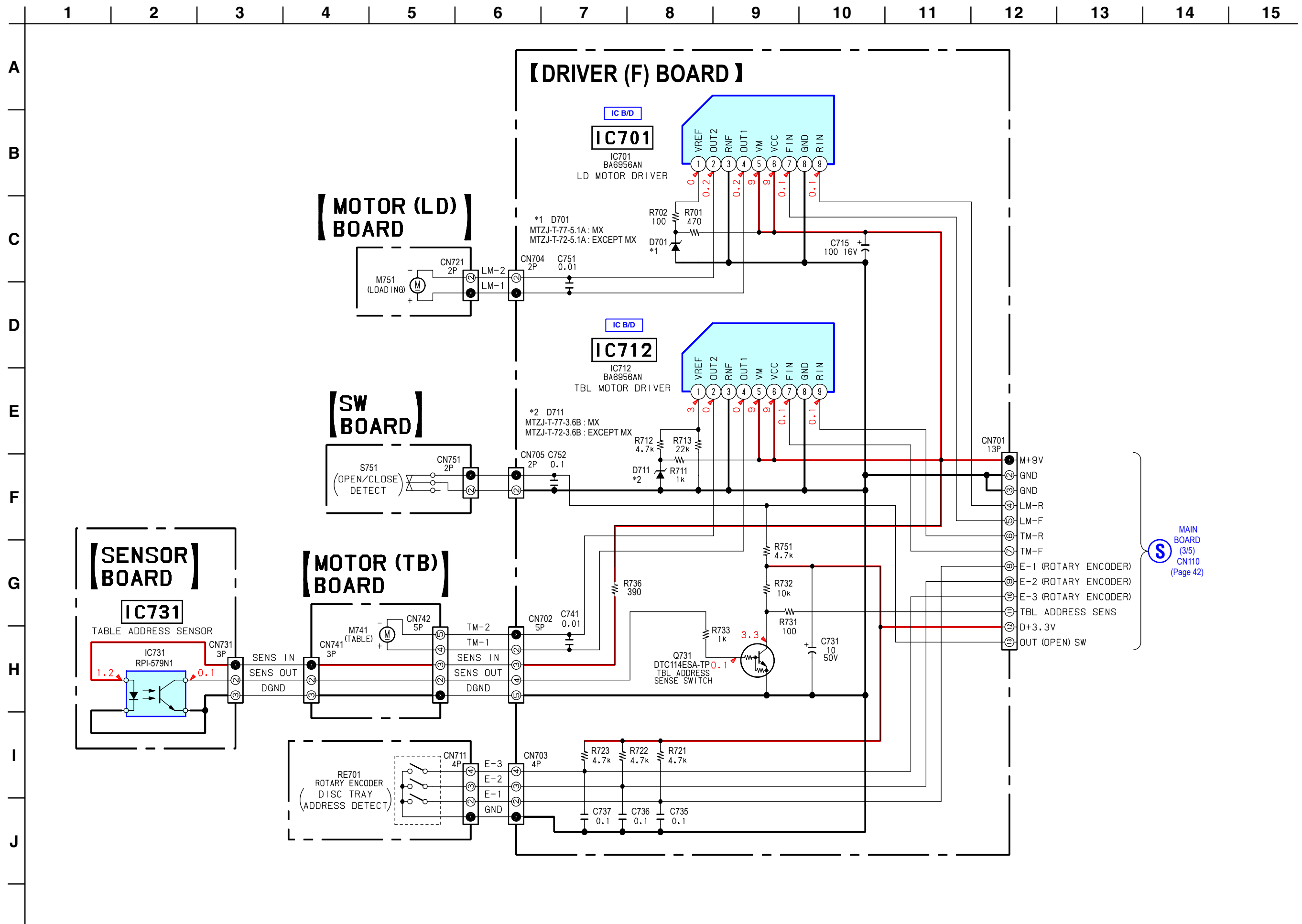

• IC Block Diagrams

IC107 TK11133CSCL-G (DMB19 Board)

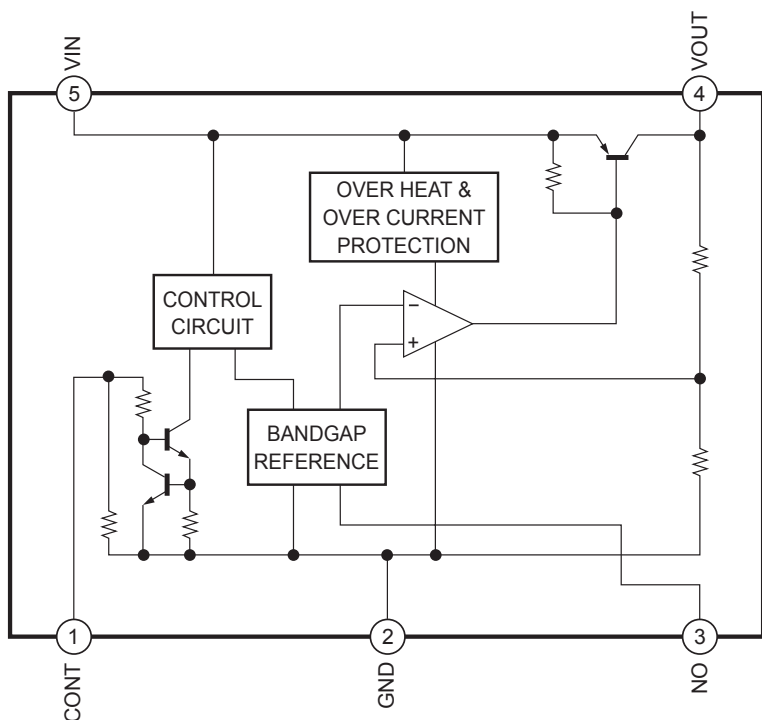

IC201 FAN8036L (DMB19 Board)

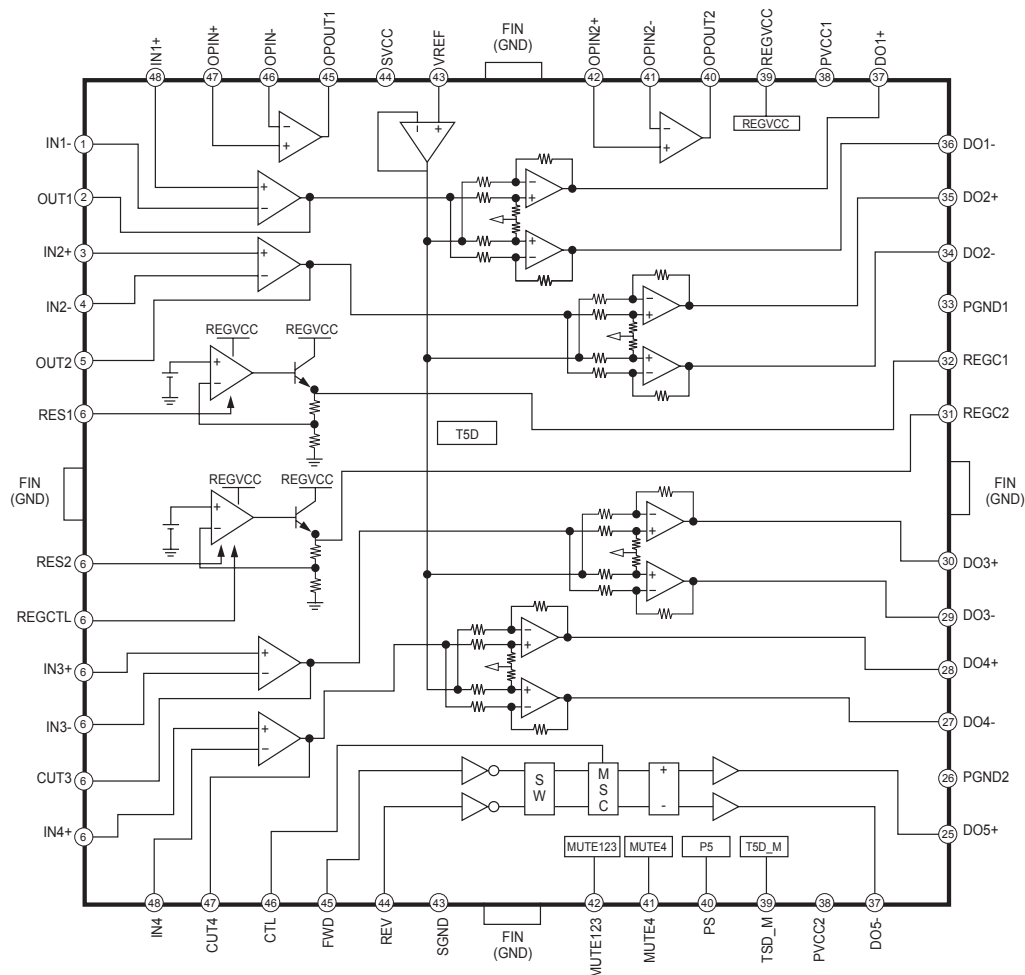

# HCD-GTR6/GTR6B/GTR7/GTR8/GTR8B

## IC4601 PCM1808PWR (DMB19 Board)

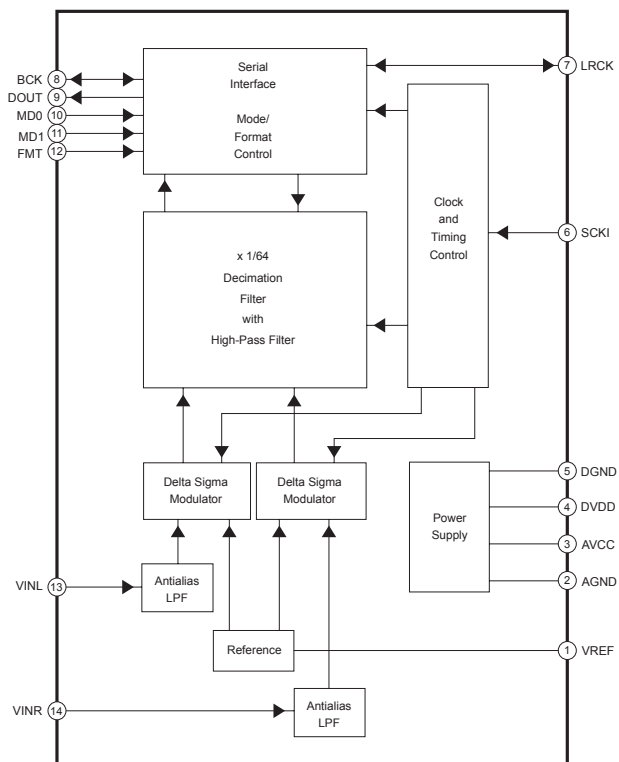

## IC4602 CS4335-KSZR (DMB19 Board)

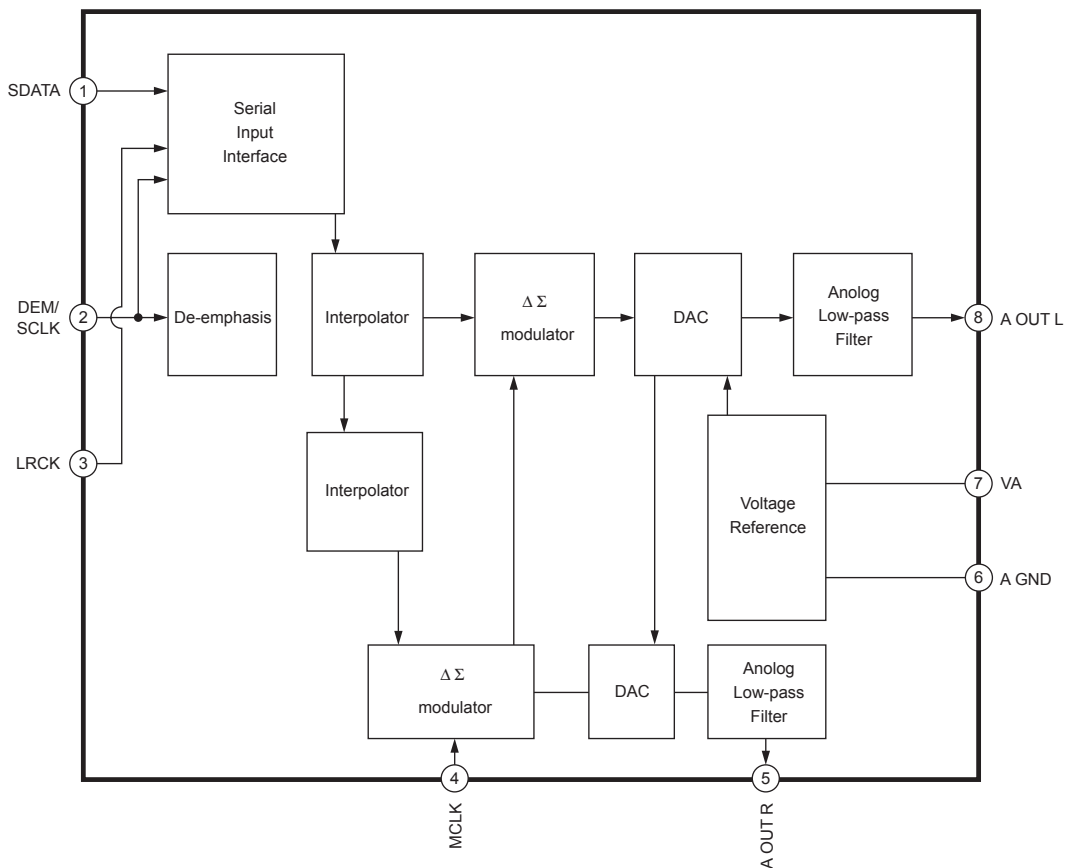

IC1500 NJM2903V (TE2) (HUB Board)

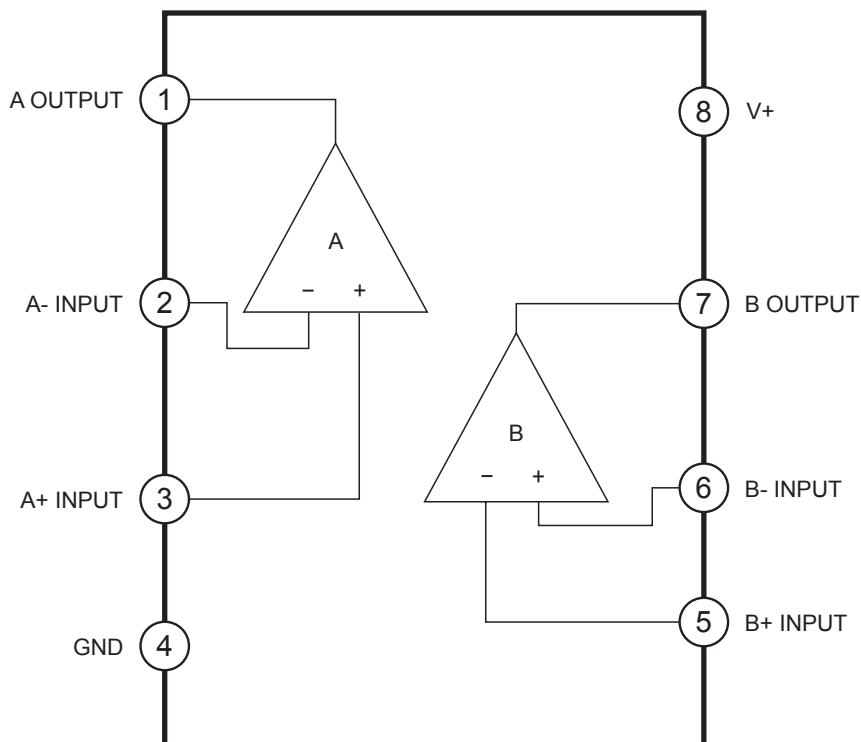

- IC251 NJM4558M-TE2 (MAIN Board)
- IC252 NJM4558M-TE2 (MAIN Board)
- IC253 NJM4558V-TE2 (MAIN Board)
- IC254 NJM4558M-TE2 (MAIN Board)
- IC450 NJM4558M-TE2 (MAIN Board)
- IC451 NJM4558M-TE2 (MAIN Board)
- IC730 NJM4558M-TE2 (MAIN Board)
- IC1000 NJM4558M-TE2 (MIC Board)

(Top View)

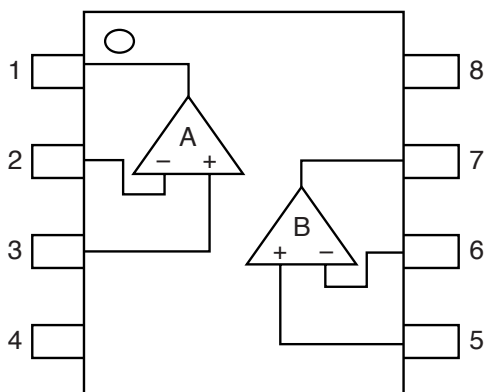

# HCD-GTR6/GTR6B/GTR7/GTR8/GTR8B

## IC400 R2A15216FP (MAIN Board)

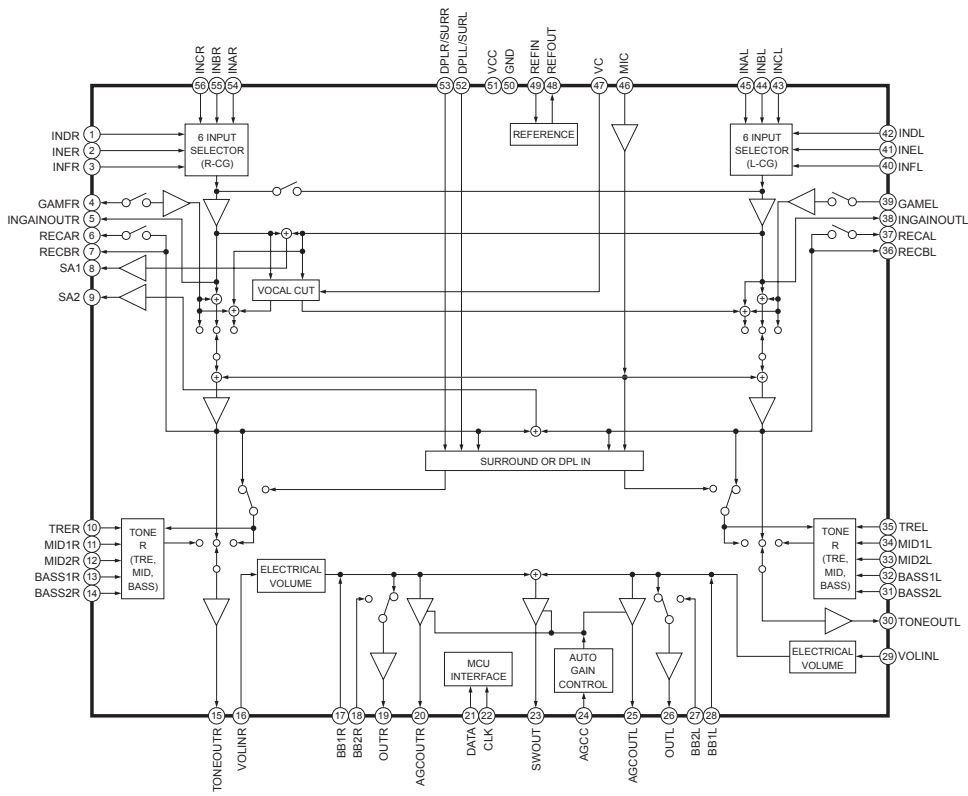

## IC675 BR24S16FJ -WE2 (MAIN Board)

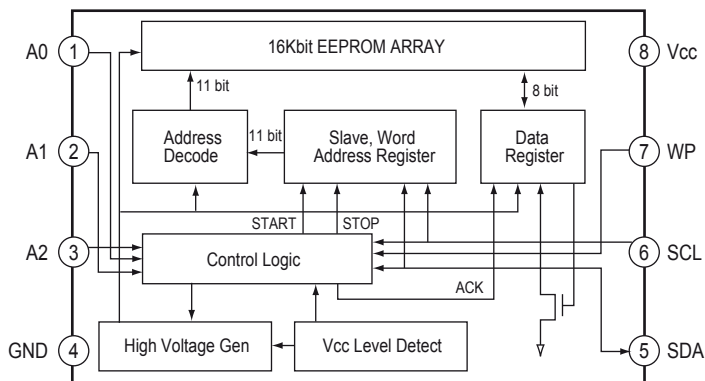

**IC800 STK433-130-E (SUB WOOFER Board)**

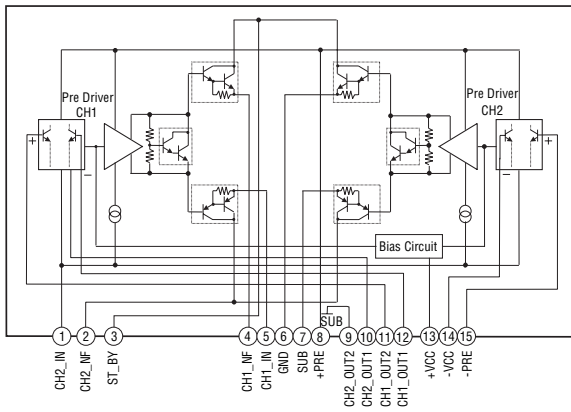

**IC701 BA6956AN (DRIVE Board)  
IC712 BA6956AN (DRIVE Board)**

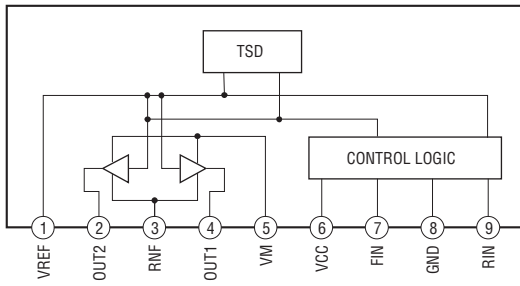

# HCD-GTR6/GTR6B/GTR7/GTR8/GTR8B

## MAIN BOARD IC500 R5F3640MDFAR (SYSTEM CONTROL)

Pin No.	Pin Name	I/O	Description
1	LED DRIVER-CLOCK	O	Clock signal for LED Driver IC.
2	LED DRIVER-DATA	O	Data signal for LED Driver IC.
3	STBY LED	O	LED drive signal output of POWER indicator.
4	SIRCS	I	Remote control signal input
5	METER BACKGROUND LED	O	Meter Background LED port control.
6	NO USE	O	Unused port (Output port setting - open)
7	LED DRIVER-LATCH	O	Latch control signal for LED Driver IC.
8	BYTE	-	Ground terminal
9	CNVss	-	Ground terminal
10	XC-IN	I	Sub system clock input terminal (32.768kHz)
11	XC-OUT	O	Sub system clock output terminal (32.768kHz)
12	RESET	I	System reset signal input from the reset signal IC "L": reset After the power supply rises, "L" is input for several hundreds msec and then change to "H".
13	X-OUT	O	Main system clock output terminal (5MHz)
14	VSS	-	Ground terminal
15	X-IN	I	Main system clock input terminal (5MHz)
16	VCC	-	Power supply terminal (+3.3V)
17	NMI	I	Non-maskable interrupt input terminal
18	USB OC 1	I	USB A over current detect pin.
19	USB OC 2	I	USB B over current detect pin.
20	AC-CUT	I	AC off detection signal input from the reset signal IC "L": AC Cut detected
21	USB HUB RESET	O	USB HUB reset port.
22	USB VBUS DET	O	USB VBUS Power detect for output enable.
23	MTK RESET	I	Disc tray status detection signal input from CDM
24	MTK XIFCS	I	MTK chip selector
25	MTK BUSY	O	MTK chip busy status output.
26	CIG BK	O	Backlight control signal for CIG (Chip In Glass) of fluorescent indicator tube.
27	USB OE	O	USB output enable port
28	CIG LATCH	O	Latch control signal for CIG (Chip In Glass) of fluorescent indicator tube.
29	IIC-CLK	I/O	Clock signal for IIC communication for Master Control controller.
30	IIC-DATA	I/O	Data signal for IIC communication for Master Control controller.
31	STK-MUTE	O	Power amplifier and sub woofer amplifier on/off control signal output "H": amplifier on
32	PROTECTOR	I	Speaker protect detection signal input from speaker protect circuit "L":protector on
33	LINK RELAY	O	Surround speaker mode control signal "H":LINK "L":MATRIX SURROUND1/2
34	LMR	O	CDM loading motor control signal output
35	CIG DATA	O	Data signal for CIG (Chip In Glass) of FL Display.
36	LMF	O	CDM loading motor control signal output
37	CIG CLK	O	Clock signal for CIG (Chip In Glass) of FL Display.
38	TMR	O	CDM turning motor control signal output
39	TMF	O	CDM turning motor control signal output
40	E-1	I	Disc tray status detection signal input from CDM
42	E-2	I	Disc tray status detection signal input from CDM
41	LED DRIVER OE	O	LED driver Output enable (H) / disable (L).
43	E-3	I	Disc tray status detection signal input from CDM
44	TBL-SENSE	I	Disc tray position detection signal input from CDM
45	SW-RELAY	O	Relay drive signal output for the passive sub woofer "H":relay on
46	OPEN-SW	I	Eject detection signal input from CDM
47	MTK SIO	O	MTK serial data out
48	MTK SOD	I	MTK serial data in
49	MTK-CLK	I	MTK serial clock
50	FR RELAY	O	Relay drive signal output for the front speakers "H":relay on
51	LINE-MUTE	O	Line muting on/off control signal "L":muting on
52	AUDIO IC DATA	O	Serial data output to audio signal IC, R2A15216FP



53	AUDIO IC CLOCK	O	Serial data transfer clock signal output to audio signal IC, R2A15216FP
54	AD SUPPLY CUT OFF	O	Micom AD Vcc supply cut off
55	MTK POWER CONTROL	I	MTK IC Power control
56	FAN ON	O	Fan on/off control port.
57	NO USE	O	Unused port (Output port setting - open)
58	ST-TUNED	I	"TUNED" input signal from Tuner pack.
59	NO USE	O	Unused port (Output port setting - open)
60	ST-CE	O	PLL chip enable signal output to the tuner unit
61	ST-DOUT (UC_DIN)	O	PLL serial data output from the tuner unit
62	VCC	-	Power supply terminal (+3.3V)
63	ST-DIN (UC_DOUT)	I	PLL serial data input to the tuner unit
64	VSS	-	Ground terminal
65	ST-CLK	O	PLL serial data transfer clock signal output to the tuner unit
66	MTK 3.3V MONITOR	I	Micom monitoring the MTK power supply pin.
67	THERMA VACS	I	Temperature detection signal input from thermistor (A/D input)
68	STBY RELAY	O	Main power on/off control signal output "H":power on
69	OVER VOLTAGE DET	I	Over-voltage protection detection input terminal "L": over-voltage detected
70	VACS-IN	I	Spectrum analyzer drive signal input from Audio IC signal (A/D input)
71	METER LEVEL IN	I	Audio signal level for Meter level detect (A/D input).
72	REC BIAS	O	Recording bias on/off control signal output "H":bias on
73	POWER KEY	I	POWER key and DISPLAY key press detection signal (Interrupt input)
74	NO USE	O	Unused port (Output port setting - open)
75	REC MUTE	O	Recording muting on/off control signal output "L":muting on
76	MIC DET	I	Mic in detect pin.
77	HP DET	I	Headphone in detect pin.
78	CAPM-CNT	O	Capstan motor drive signal output
79	B-TRIG	O	Deck side trigger plunger drive signal output "H":plunger on
80	B SHUT	I	Shut off detection signal input from deck A side reel pulse detector (A/D input)
81	B-HALF/REC	I	Deck B cassette detection, forward side recording tab detection and reverse side recording tab detection signal input terminal (A/D input)
82	TC-RELAY	O	Recording/playback selection signal output "H":recording "L":playback
83	METER IN2	O	Meter motor control port
84	METER IN1	O	Meter motor control port
85	METER IN3	O	Meter motor control port
86	METER IN4	O	Meter motor control port
87	METER SW	I	Meter position switch (Initial & End Position) for calibration purpose.
88	AD-KEY-1	I	Key input terminal for AD key line 1.
89	AD-KEY-0	I	Key input terminal for AD key line 0.
90	AD-KEY-2	I	Key input terminal for AD key line 2.
91	MODEL-IN	I	Model setting terminal (A/D input)
92	DEST-IN	I	Destination setting terminal (A/D input)
93	OPERATION DIAL	I	Jog dial pulse input from OPERATION DIAL encoder
94	MASTER VOLUME	I	Jog dial pulse input from the VOLUME encoder
95	EEPROM CLOCK	I/O	External EEPROM memory backup (Serial Clock line)
96	AVSS	I	Ground terminal (for A/D conversion)
97	EEPROM DATA	I/O	External EEPROM memory backup (Serial Data line)
98	VREF	I	A/D Converter reference voltage input terminal (+3.3V)
99	AVCC	-	Power supply terminal (+3.3V) (for A/D conversion)
100	METER-BLUE	O	LED drive signal output of Meter backlight LED

## SECTION 6 EXPLODED VIEWS

**NOTE:**

- The mechanical parts with no reference number in the exploded views are not supplied.
- Items marked “\*” are not stocked since they are seldom required for routine service. Some delay should be anticipated when ordering these items.
- -XX and -X mean standardized parts, so they may have some difference from the original one.

- Accessories are given in the last of this parts list.
- Abbreviation  
 E2 : 120V AC area in E model  
 E3 : 240V AC area in E model  
 E51 : Chilean and Peruvian model  
 AR : Argentina model  
 AUS : Australian model  
 MX : Mexican model

The components identified by mark  $\triangle$  or dotted line with mark  $\triangle$  are critical for safety. Replace only with part number specified.

### 6-1. MAIN SECTION

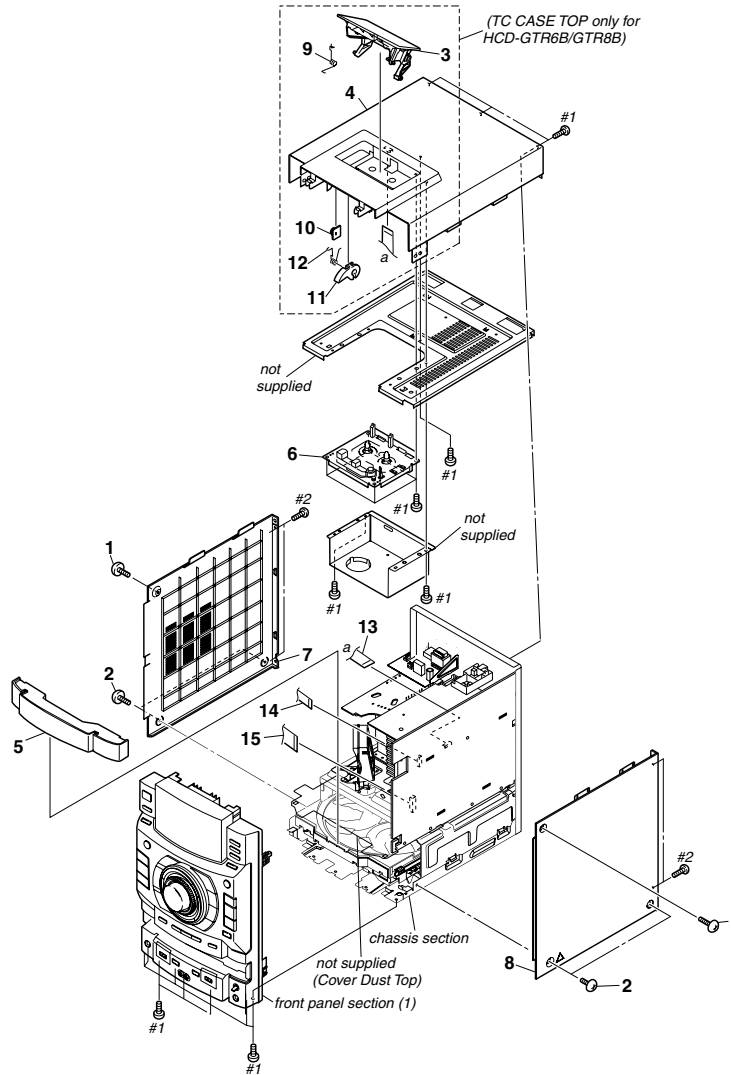

Ref. No.	Part No.	Description	Remark	Ref. No.	Part No.	Description	Remark
1	3-363-099-32	SCREW (CASE 3 TP2)		8	4-126-674-01	PANEL, SIDE R (P)	
2	3-363-099-02	SCREW (CASE 3 TP2)		9	4-126-693-01	SPRING (TC) (GTR6B/GTR8B)	
3	4-126-672-01	HOLDER (TC) (GTR6B/GTR8B)		10	4-224-104-11	DAMPER (GTR6B/GTR8B)	
4	4-126-671-01	CASE, TOP (GTR6B/GTR8B)		11	4-231-824-01	CAM (A), HEART (GTR6B/GTR8B)	
4	4-132-615-01	CASE, TOP (GTR6/GTR7/GTR8)		12	4-231-836-01	SPRING (HEART CAM-A) (GTR6B/GTR8B)	
5	4-126-663-11	PANEL, LOADING (GTR8)		13	1-827-995-11	WIRE (FLAT TYPE) (7 CORE) (GTR6B/GTR8B)	
5	4-126-663-01	PANEL, LOADING (GTR8B)		14	1-827-720-11	WIRE (FLAT TYPE) (11 CORE)	
5	4-126-663-31	PANEL, LOADING (GTR7)		15	1-829-023-11	WIRE (FLAT TYPE) (23 CORE)	
5	4-126-663-41	PANEL, LOADING (GTR6B)		#1	7-685-646-79	SCREW +BVTP 3X8 TYPE 2 IT-3	
5	4-126-663-51	PANEL, LOADING (GTR6)		#2	7-685-871-01	SCREW +BVTT 3X6 (S)	
6	1-840-020-11	MECHA DECK (GTR6B/ GTR8B)					
7	4-126-673-01	PANEL, SIDE L (P)					

6-2. BACK PANEL SECTION

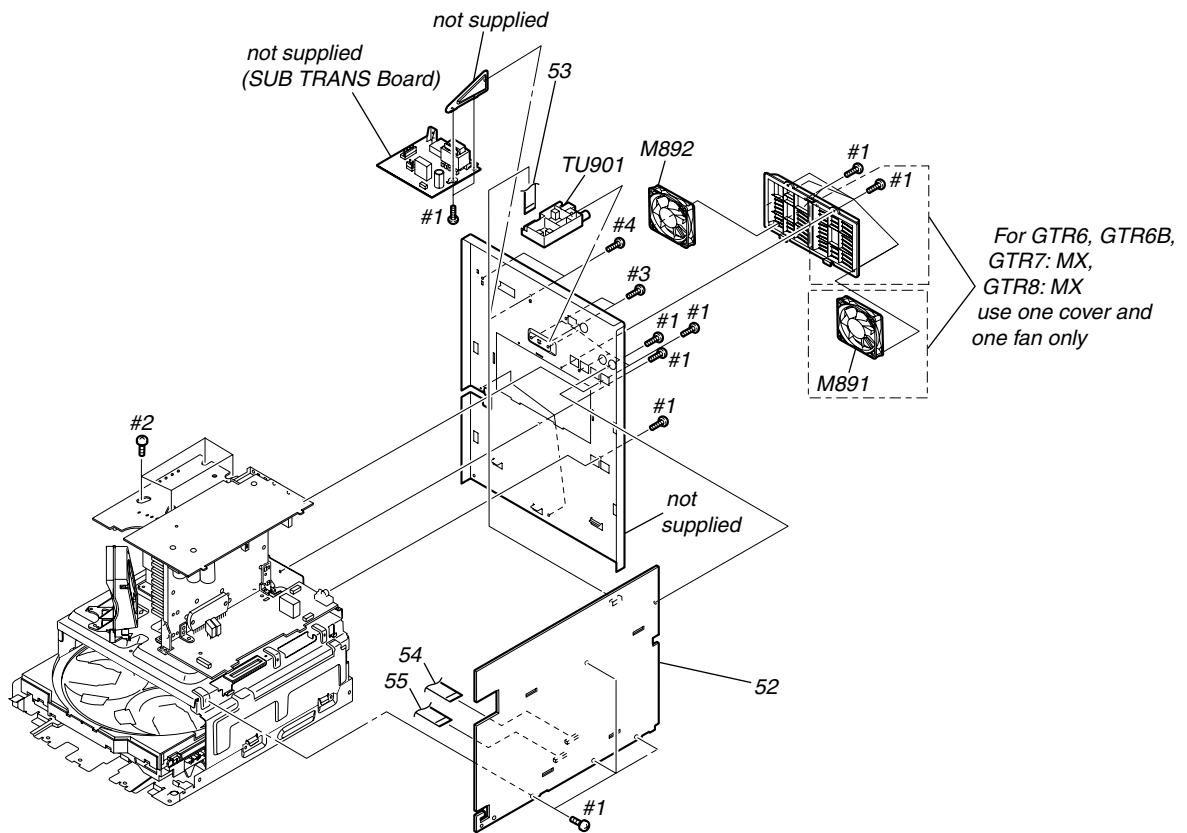

Ref. No.	Part No.	Description	Remark	Ref. No.	Part No.	Description	Remark
52	A-1702-138-A	MAIN BOARD, COMPLETE (GTR8B: E3)		52	A-1724-754-A	MAIN BOARD, COMPLETE (GTR6B: AUS)	
52	A-1702-161-A	MAIN BOARD, COMPLETE (GTR8:E2)		52	A-1724-757-A	MAIN BOARD, COMPLETE (GTR6: E51, AR)	
52	A-1702-168-A	MAIN BOARD, COMPLETE (GTR6B: E3)		53	1-828-938-51	WIRE (FLAT TYPE) (9 CORE)	
52	A-1724-710-A	MAIN BOARD, COMPLETE (GTR8: E51, AR)		54	1-828-975-11	WIRE (FLAT TYPE) (13 CORE)	
52	A-1724-712-A	MAIN BOARD, COMPLETE (GTR8B: AUS)		55	1-828-384-11	WIRE (FLAT TYPE) (23 CORE)	
52	A-1724-715-A	MAIN BOARD, COMPLETE (GTR8: MX)		M891	1-787-344-11	FAN, DC (GTR7/GTR8:MX/GTR6/GTR6B)	
52	A-1724-746-A	MAIN BOARD, COMPLETE (GTR7: E2)		M892	1-787-344-11	FAN, DC (GTR7/GTR8/GTR8B)	
52	A-1724-748-A	MAIN BOARD, COMPLETE (GTR7: E51, AR)		TU901	1-693-778-21	TUNER (FM/AM)	
52	A-1724-750-A	MAIN BOARD, COMPLETE (GTR7: MX)		#1	7-685-646-79	SCREW +BVTP 3X8 TYPE 2 IT-3	
52	A-1724-752-A	MAIN BOARD, COMPLETE (GTR6: E2)		#2	4-900-386-01	SCREW +BVTT 4X8	
				#3	7-685-872-01	SCREW 3X6	
				#4	7-685-647-79	SCREW +BVTP 3X10 TYPE 2 IT-3	

## 6-3. FRONT PANEL SECTION (1)

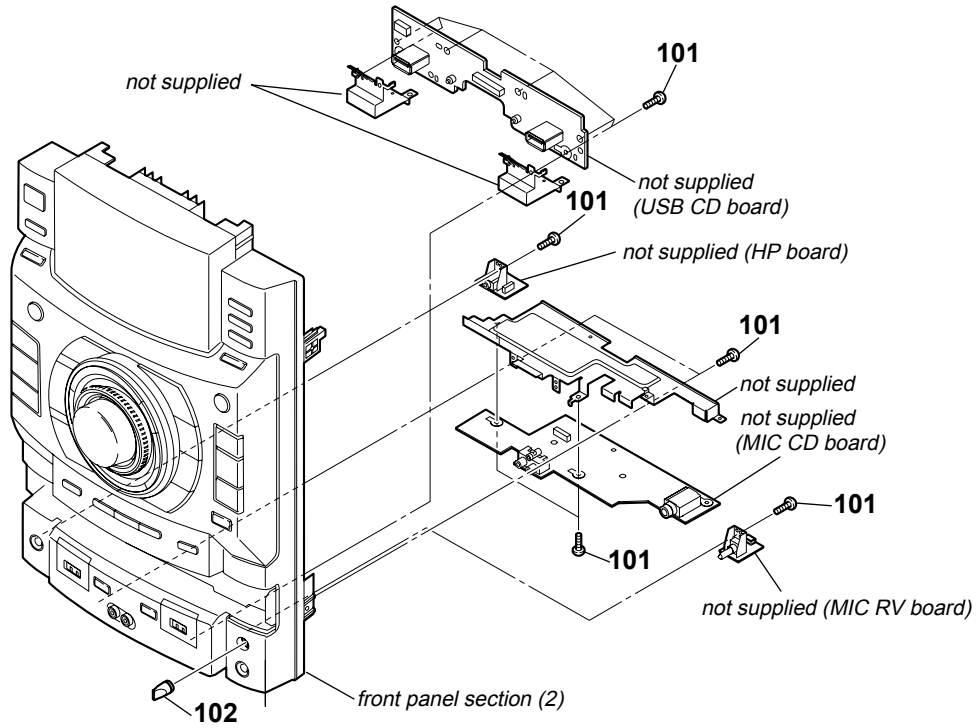

Ref. No.	Part No.	Description	Remark
101	3-087-053-01	+BVTP2.6 (3CR)	
102	2-895-507-01	KNOB (MIC)	

6-4. FRONT PANEL SECTION (2)

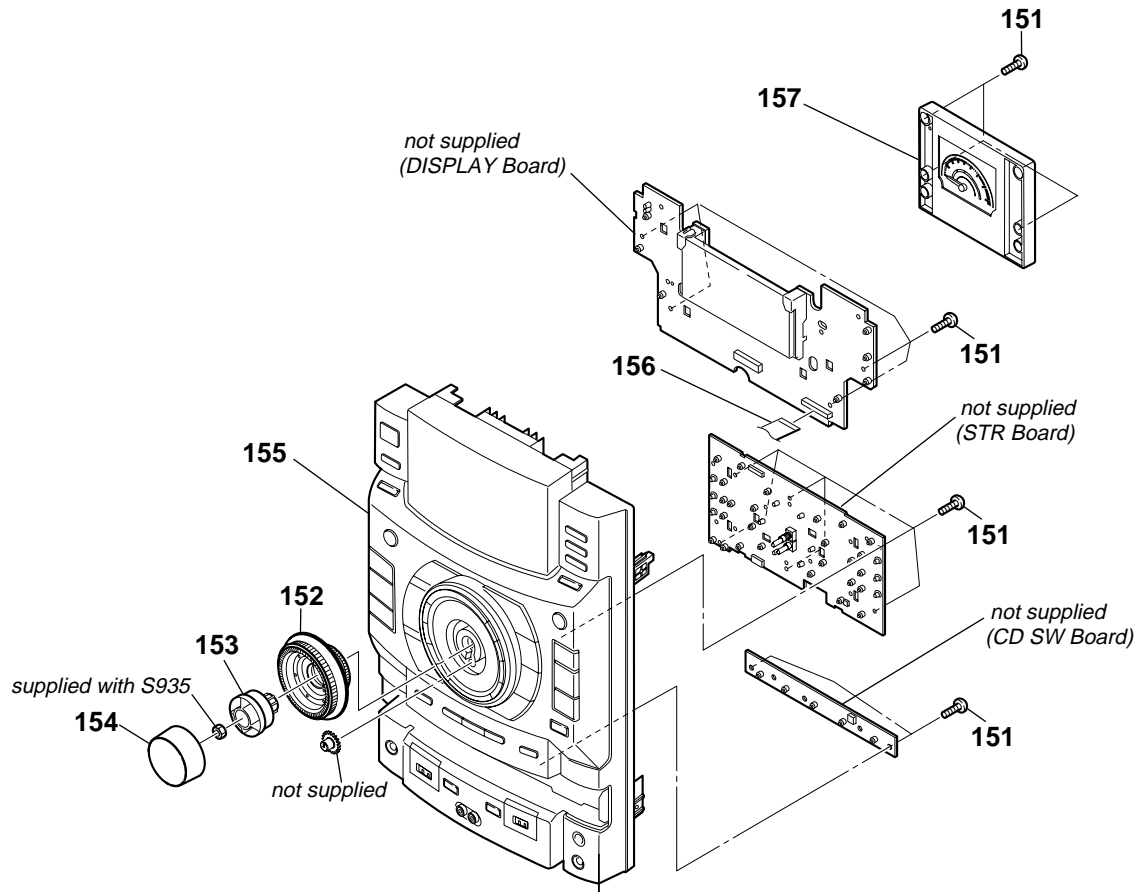

Ref. No.	Part No.	Description	Remark
151	3-087-053-01	+BVTP2.6 (3CR)	
152	X-2345-785-1	KNOB JOG-P ASSY	
153	4-126-656-02	HOLDER (JOG)	
154	4-126-651-01	KNOB (VOLUME)	
155	X-2345-782-1	PANEL, FRONT ASSY (GTR6 ASIA) (GTR6B)	
155	X-2345-783-1	PANEL, FRONT ASSY (GTR6 LATIN) (GTR6)	
155	X-2345-780-1	PANEL, FRONT ASSY (GTR8 ASIA) (GTR8B)	
155	X-2345-781-1	PANEL, FRONT ASSY (GTR8 LATIN) (GTR7/GTR8)	
156	1-829-023-11	WIRE (FLAT TYPE) (23 CORE)	
157	A-1718-281-A	METER DISPLAY ASSY(GTH)	

6-5. CHASSIS SECTION

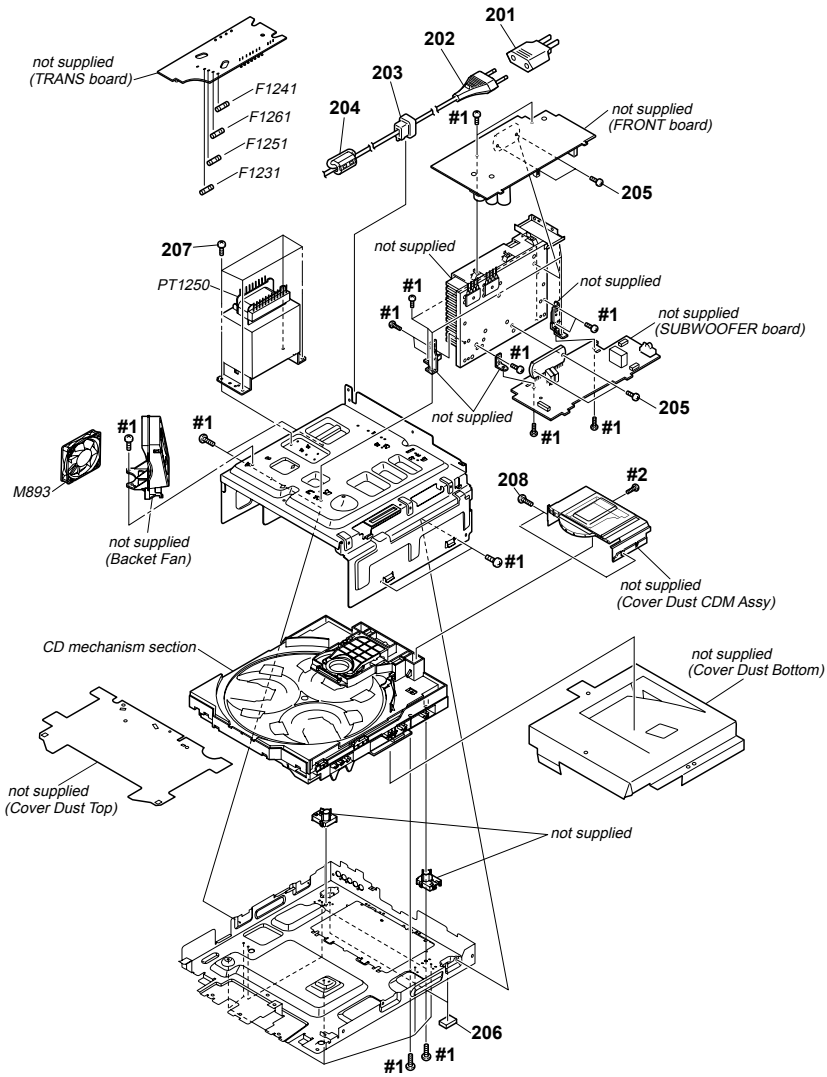

Ref. No.	Part No.	Description	Remark	Ref. No.	Part No.	Description	Remark
△ 201	1-569-008-22	ADAPTOR, CONVERSION (E2, E51, E3)		△ F1251	1-533-949-33	FUSE, CYLINDRICAL (TIME LAG) (T8AL/250V)	
△ 202	1-777-071-83	CORD, POWER (E2, E51, E3)		△ F1261	1-533-949-33	FUSE, CYLINDRICAL (TIME LAG) (T8AL/250V)	
△ 202	1-829-259-11	CORD, POWER (AUS)		M893	1-763-372-11	FAN, DC (GTR7/GTR8/GTR8B)	
△ 202	1-829-387-11	CORD, POWER (AR)		△ PT1250	1-445-632-11	POWER TRANSFORMER (GTR6/GTR6B)	
203	3-703-244-00	CORD BUSH (2104) (EXCEPT MX)		△ PT1250	1-445-637-11	POWER TRANSFORMER (GTR8: E2, E51, AR/GTR8B)	
203	3-703-571-11	CORD BUSH (4516) (MX)		△ PT1250	1-445-640-11	POWER TRANSFORMER (GTR7:E2, E51, AR)	
204	1-457-369-12	CORE, FERRITE		△ PT1250	1-445-709-11	POWER TRANSFORMER (GTR8:MX)	
205	3-905-609-31	SCREW (TRANSISTOR)		△ PT1250	1-445-708-11	POWER TRANSFORMER (GTR7:MX)	
206	4-225-252-21	CUSHION (FOOT)		#1	7-685-646-79	SCREW +BVTP 3X8 TYPE 2 IT-3	
207	4-900-386-01	SCREW		#2	7-685-647-79	SCREW +BVTP 3X10 TYPE 2 IT-3	
208	4-218-253-62	SCREW (M2.6) +BTTP					
△ F1231	1-533-949-33	FUSE, CYLINDRICAL (TIME LAG) (T8AL/250V)					
△ F1241	1-533-949-33	FUSE, CYLINDRICAL (TIME LAG) (T8AL/250V)					

6-6. CD MECHANISM SECTION (1)  
(CDM74KF-K6BD93UR-WOD)

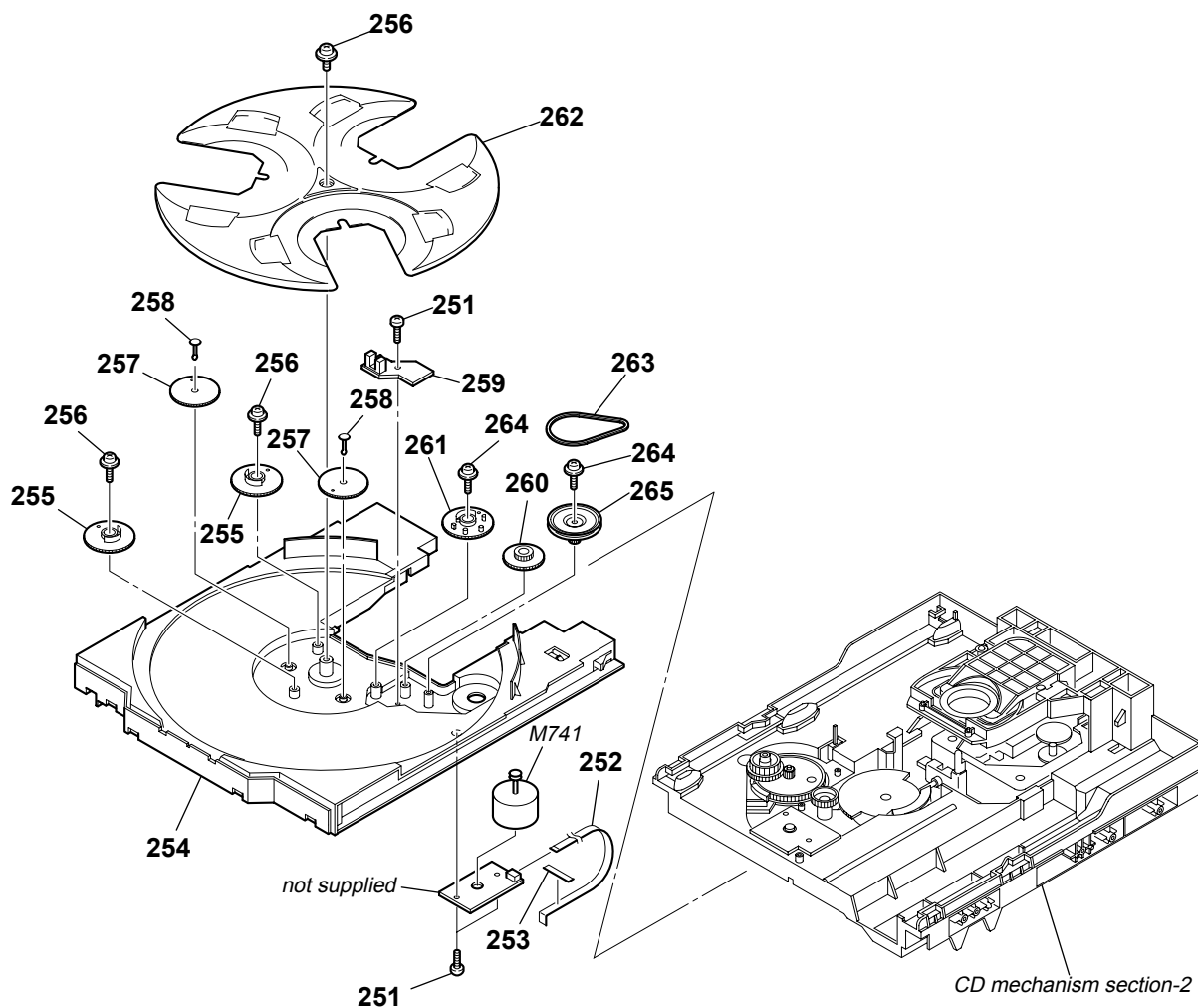

Ref. No.	Part No.	Description	Remark	Ref. No.	Part No.	Description	Remark
251	4-218-253-42	SCREW (M2.6), +BTTP (MX)		260	4-243-820-01	GEAR (TABLE)	
252	1-828-938-51	WIRE (FLAT TYPE) (5 CORE) (EXCEPT MX)		261	4-243-819-01	GEAR (GENEVA)	
253	1-776-182-11	WIRE (FLAT TYPE) (5 CORE) (MX)		262	4-243-816-21	TRAY	
254	3-231-598-01	SHEET (BA)		263	4-243-823-01	BELT (TABLE) (MX)	
	4-243-815-11	TABLE (LOADING)		263	4-243-823-11	BELT (TABLE) (EXCEPT MX)	
255	4-245-571-02	GEAR (STOPPER)		264	4-985-672-01	SCREW (+PTPWH M2.6), FLOATING	
256	4-218-252-61	SCREW (+PTPWH M2.6), FLOATING		265	4-243-821-01	PULLEY (TABLE)	
257	4-245-570-01	GEAR (JOINT)		M741	A-1108-965-A	MOTOR ASSY, TABLE	
258	4-245-572-01	BUSHING (GEAR)					
259	1-687-132-12	SENSOR BOARD					

6-7. CD MECHANISM SECTION (2)  
(CDM74KF-K6BD93UR-WOD)

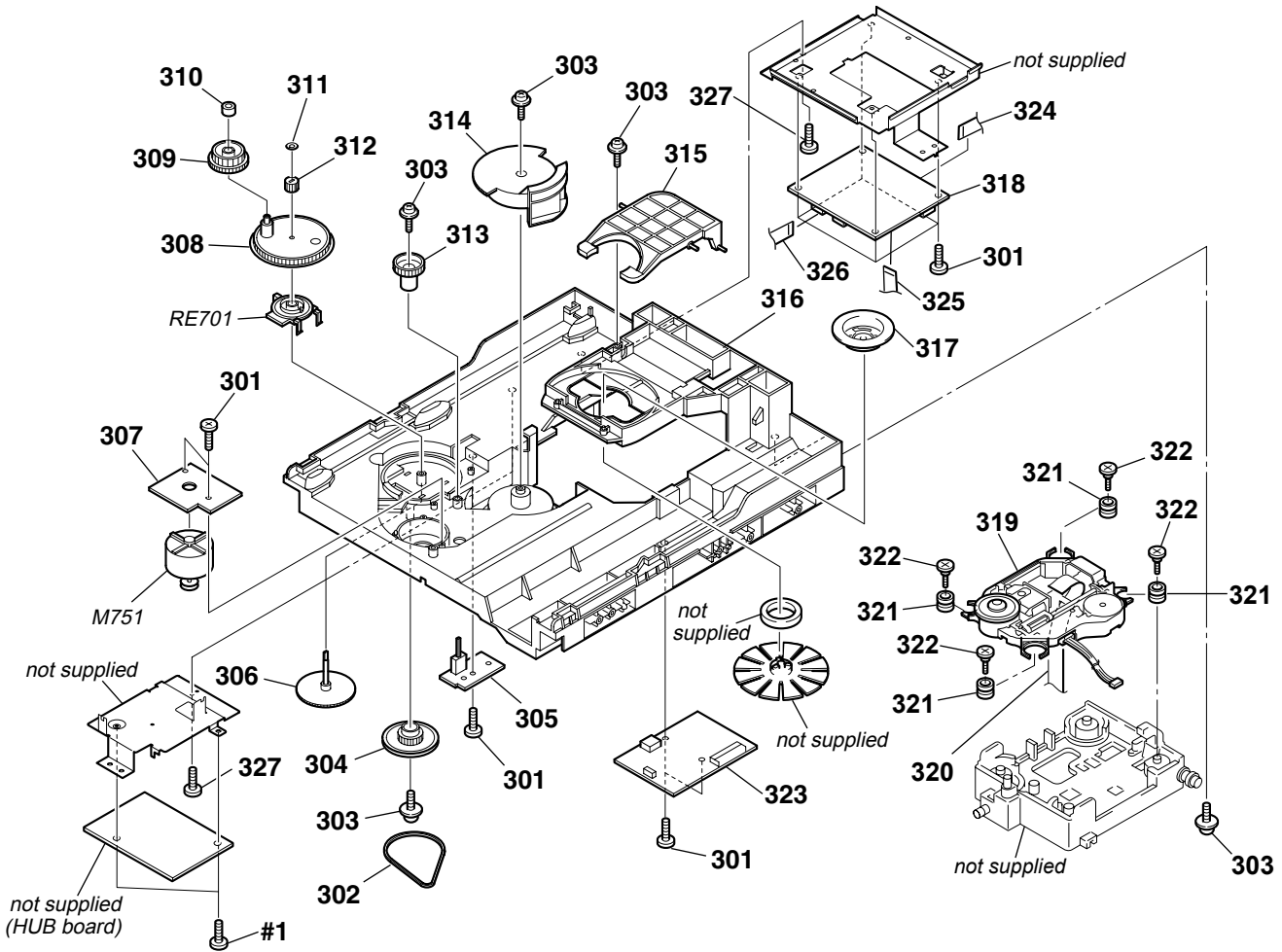

Ref. No.	Part No.	Description	Remarks	Ref. No.	Part No.	Description	Remarks
301	4-218-253-52	SCREW (M2.6), +BTTP		317	2-345-983-01	PULLEY B (310), CHUCKING	
302	4-244-034-01	BELT (LOADING) (MX)		318	A-1653-554-A	DMB19 BOARD, COMPLETE (EXCEPT MX)	
302	4-244-034-11	BELT (LOADING)		318	A-1653-555-A	DMB19 BOARD, COMPLETE (MX)	
303	4-218-252-52	SCREW (+PTPWH M2.6), FLOATING		319	8-820-322-04	DEVICE, OPTICAL KHM-313CAB/C2RP	
304	4-225-844-01	GEAR (LOADING A)		320	1-829-023-11	WIRE (FLAT TYPE) (23 CORE)	
305	1-687-669-12	SW BOARD		321	2-634-618-01	INSULATOR	
306	4-224-613-11	GEAR (SHAFT)		322	3-087-599-01	INSULATOR SCREW	
307	1-687-134-12	MOTOR (TB) BOARD		323	A-103-756-B	DRIVE BOARD (EXCEPT MX)	
308	4-244-108-01	GEAR, SWING		324	1-828-310-11	WIRE (FLAT TYPE) (9 CORE)	
309	4-224-609-01	GEAR (LOADING C)		325	1-828-252-11	WIRE (FLAT TYPE) (24 CORE)	
310	4-224-608-01	COLLAR, SWING		326	1-828-302-11	WIRE (FLAT TYPE) (7 CORE)	
311	3-016-533-11	WASHER (FR), STOPPER		327	3-087-053-01	+BVTP 2.6 (3CR)	
312	4-224-611-01	GEAR (LOADING B)		M751	A-1108-966-A	MOTOR ASSY, LOADING (EXCEPT MX)	
313	4-224-606-01	GEAR (RV)		M751	A-4737-553-A	MOTOR ASSY, LOADING (MX)	
314	4-243-818-01	GEAR (U/D)		RE701	1-477-680-12	ENCODER, ROTARY	
315	2-541-918-01	LEVER (LIFTER (H))		#1	7-685-647-79	SCREW +BVTP 3X10 TYPE2 IT-3	
316	4-243-817-22	CHASSIS (MX)					



SECTION 7  
ELECTRICAL PARTS LIST

CD SW DISPLAY

Note:

- Due to standardization, replacements in the parts list may be different from the parts specified in the diagrams or the components used on the set.
- -XX and -X mean standardized parts, so they may have some difference from the original one.
- Items marked "\*" are not stocked since they are seldom required for routine service. Some delay should be anticipated when ordering these items.
- CAPACITORS  
uF: μF

- COILS  
uH: μH
- RESISTORS  
All resistors are in ohms.  
METAL: Metal-film resistor.  
METAL OXIDE: Metal oxide-film resistor.  
F: nonflammable
- SEMICONDUCTORS  
In each case, u: μ, for example:  
uA. . . : μA. . . , uPA. . . , μPA. . . ,  
uPB. . . : μPB. . . , uPC. . . , μPC. . . ,  
uPD. . . : μPD. . .
- Accessories are given in the last of this parts list.

The components identified by mark Δ or dotted line with mark Δ are critical for safety. Replace only with part number specified.

When indicating parts by reference number, please include the board name.

- Abbreviation  
E2 : 120V AC area in E model  
E3 : 240V AC area in E model  
E51 : Chilean and Peruvian model  
AR : Argentina model  
AUS : Australian model  
MX : Mexican model

Ref. No.	Part No.	Description	Remark	Ref. No.	Part No.	Description	Remark
		CD SW BOARD *****		D901	6-502-469-01	DIODE SLI-325URT31	
		< CONNECTOR >		D902	6-502-244-01	DIODE KDZTR2.7B	
CN901	1-785-328-11	PIN, CONNECTOR (LIGHT ANGRE) 2P				< IC >	
		< RESISTOR >		IC900	6-600-768-01	IC PNA4823M03S0	
R991	1-216-837-11	METAL CHIP 22K 5% 1/10W				< FLUORESCENT INDICATOR TUBE >	
R992	1-216-835-11	METAL CHIP 15K 5% 1/10W		ND900	1-483-082-11	VACUUM FLUORESCENT DISPLAYS	
R993	1-216-833-11	METAL CHIP 10K 5% 1/10W				< TRANSISTOR >	
R994	1-218-867-11	METAL CHIP 6.8K 0.5% 1/10W		Q900	8-729-620-07	TRANSISTOR 2SC3052EF-T1-LEF	
R995	1-216-839-11	METAL CHIP 33K 5% 1/10W		Q901	8-729-620-07	TRANSISTOR 2SC3052EF-T1-LEF	
		< SWITCH >		Q902	8-729-620-07	TRANSISTOR 2SC3052EF-T1-LEF	
S950	1-771-410-21	SWITCH, TACTILE (EX-CHANGE/DISC SKIP)		Q903	8-729-620-07	TRANSISTOR 2SC3052EF-T1-LEF	
S951	1-771-410-21	SWITCH, TACTILE (DISC 1)				< RESISTOR >	
S952	1-771-410-21	SWITCH, TACTILE (DISC 2)		R900	1-216-817-11	METAL CHIP 470 5% 1/10W	
S953	1-771-410-21	SWITCH, TACTILE (DISC 3)		R901	1-216-821-11	METAL CHIP 1K 5% 1/10W	
S954	1-771-410-21	SWITCH, TACTILE (OPEN/CLOSE)		R902	1-216-821-11	METAL CHIP 1K 5% 1/10W	
*****				R903	1-216-809-11	METAL CHIP 100 5% 1/10W	
		DISPLAY BOARD *****		R904	1-216-001-00	METAL CHIP 10 5% 1/10W	
		< CAPACITOR >		R905	1-216-001-00	METAL CHIP 10 5% 1/10W	
C901	1-115-467-11	CERAMIC CHIP 0.22uF 10% 10V		R906	1-216-823-11	METAL CHIP 1.5K 5% 1/10W	
C903	1-163-077-00	CERAMIC CHIP 0.1uF 50V		R907	1-216-823-11	METAL CHIP 1.5K 5% 1/10W	
C904	1-164-156-11	CERAMIC CHIP 0.1uF 25V		R908	1-216-821-11	METAL CHIP 1K 5% 1/10W	
C905	1-100-597-91	CERAMIC CHIP 0.1uF 10% 25V		R909	1-216-821-11	METAL CHIP 1K 5% 1/10W	
C906	1-126-176-11	ELECT 220uF 20% 10V		R910	1-216-819-11	METAL CHIP 680 5% 1/10W	
C907	1-124-584-00	ELECT 100uF 20% 6.3V		R911	1-216-817-11	METAL CHIP 470 5% 1/10W	
C910	1-162-927-11	CERAMIC CHIP 100PF 5% 50V		R919	1-216-809-11	METAL CHIP 100 5% 1/10W	
C911	1-162-927-11	CERAMIC CHIP 100PF 5% 50V		R920	1-216-809-11	METAL CHIP 100 5% 1/10W	
C912	1-162-927-11	CERAMIC CHIP 100PF 5% 50V		R921	1-216-809-11	METAL CHIP 100 5% 1/10W	
C913	1-162-927-11	CERAMIC CHIP 100PF 5% 50V		R922	1-216-809-11	METAL CHIP 100 5% 1/10W	
C1056	1-126-969-11	ELECT 220uF 20% 50V		R923	1-216-825-11	METAL CHIP 2.2K 5% 1/10W	
C1125	1-100-597-91	CERAMIC CHIP 0.1uF 10% 25V		R924	1-216-827-11	METAL CHIP 3.3K 5% 1/10W	
C1132	1-164-156-11	CERAMIC CHIP 0.1uF 25V	(AUS)	R925	1-216-809-11	METAL CHIP 100 5% 1/10W	
		< CONNECTOR >		R926	1-216-809-11	METAL CHIP 100 5% 1/10W	
CN902	1-784-784-11	CONNECTOR, FFC 23P		R927	1-216-845-11	METAL CHIP 100K 5% 1/10W	
		< DIODE >		R928	1-216-845-11	METAL CHIP 100K 5% 1/10W	
D900	8-719-060-27	DIODE SLR-325MCT31		R996	1-216-827-11	METAL CHIP 3.3K 5% 1/10W	
				R997	1-216-841-11	METAL CHIP 47K 5% 1/10W	
				R998	1-216-841-11	METAL CHIP 47K 5% 1/10W	
				R1148	1-216-821-11	METAL CHIP 1K 5% 1/10W	
				R1149	1-216-821-11	METAL CHIP 1K 5% 1/10W	

# HCD-GTR6/GTR6B/GTR7/GTR8/GTR8B

**DISPLAY** **DMB19**

Ref. No.	Part No.	Description	Remark	Ref. No.	Part No.	Description	Remark
		< SWITCH >					
S900	1-771-410-21	SWITCH, TACTILE (REC TIMER)		C203	1-162-970-11	CERAMIC CHIP 0.01uF 10%	25V
S901	1-771-410-21	SWITCH, TACTILE (REC TO TAPE)	(GTR6B/GTR8B)	C205	1-164-230-11	CERAMIC CHIP 220PF 5%	50V
S902	1-771-410-21	SWITCH, TACTILE (OPTIONS)		C206	1-164-230-11	CERAMIC CHIP 220PF 5%	50V
S903	1-771-410-21	SWITCH, TACTILE (DISPLAY)		C208	1-162-970-11	CERAMIC CHIP 0.01uF 10%	25V
S904	1-771-410-21	SWITCH, TACTILE (POWER)		C209	1-164-677-11	CERAMIC CHIP 0.033uF 10%	16V
S905	1-771-410-21	SWITCH, TACTILE		C210	1-162-970-11	CERAMIC CHIP 0.01uF 10%	25V
S906	1-771-410-21	SWITCH, TACTILE		C211	1-164-677-11	CERAMIC CHIP 0.033uF 10%	16V
*****							
	A-1653-554-A	DMB19 BOARD, COMPLETE (EXCEPT MX)		C212	1-162-970-11	CERAMIC CHIP 0.01uF 10%	25V
	A-1653-555-A	DMB19 BOARD, COMPLETE (MX)		C213	1-162-970-11	CERAMIC CHIP 0.01uF 10%	25V
		*****		C214	1-162-964-11	CERAMIC CHIP 0.001uF 10%	50V
		< CAPACITOR >		C215	1-162-970-11	CERAMIC CHIP 0.01uF 10%	25V
C101	1-162-970-11	CERAMIC CHIP 0.01uF 10%	25V	C216	1-162-970-11	CERAMIC CHIP 0.01uF 10%	25V
C102	1-124-259-11	CERAMIC CHIP 4.7uF 20%	16V	C217	1-117-681-11	ELECT CHIP 100uF 20%	16V
C105	1-128-994-21	ELECT CHIP 47uF 20%	10V	C218	1-128-994-21	ELECT CHIP 47uF 20%	10V
C106	1-162-970-11	CERAMIC CHIP 0.01uF 10%	25V	C219	1-162-970-11	CERAMIC CHIP 0.01uF 10%	25V
C108	1-162-965-11	CERAMIC CHIP 0.0015uF 10%	50V	C220	1-128-994-21	ELECT CHIP 47uF 20%	10V
C111	1-107-826-11	CERAMIC CHIP 0.1uF 10%	16V	C221	1-164-360-11	CERAMIC CHIP 0.1uF	16V
C112	1-128-994-21	ELECT CHIP 47uF 20%	10V	C222	1-164-360-11	CERAMIC CHIP 0.1uF	16V
C113	1-162-970-11	CERAMIC CHIP 0.01uF 10%	25V	C224	1-162-970-11	CERAMIC CHIP 0.01uF 10%	25V
C115	1-107-826-11	CERAMIC CHIP 0.1uF 10%	16V	C233	1-162-968-11	CERAMIC CHIP 0.0047uF 10%	50V
C116	1-107-826-11	CERAMIC CHIP 0.1uF 10%	16V	C502	1-125-891-11	CERAMIC CHIP 0.47uF 10%	10V
C118	1-124-779-00	ELECT CHIP 10uF 20%	16V	C602	1-128-995-21	ELECT CHIP 100uF 20%	10V
C119	1-137-710-91	CERAMIC CHIP 10uF 20%	6.3V	C603	1-128-995-21	ELECT CHIP 100uF 20%	10V
C124	1-165-908-11	CERAMIC CHIP 1uF 10%	10V	C604	1-128-995-21	ELECT CHIP 100uF 20%	10V
C125	1-107-826-11	CERAMIC CHIP 0.1uF 10%	16V	C608	1-107-826-11	CERAMIC CHIP 0.1uF 10%	16V
C126	1-137-710-91	CERAMIC CHIP 10uF 20%	6.3V	C611	1-100-566-91	CERAMIC CHIP 0.1uF 10%	25V
C127	1-165-908-11	CERAMIC CHIP 1uF 10%	10V	C620	1-164-360-11	CERAMIC CHIP 0.1uF	16V
C144	1-162-970-11	CERAMIC CHIP 0.01uF 10%	25V	C621	1-164-360-11	CERAMIC CHIP 0.1uF	16V
C145	1-162-970-11	CERAMIC CHIP 0.01uF 10%	25V	C622	1-164-360-11	CERAMIC CHIP 0.1uF	16V
C146	1-165-908-11	CERAMIC CHIP 1uF 10%	10V	C623	1-164-360-11	CERAMIC CHIP 0.1uF	16V
C149	1-162-970-11	CERAMIC CHIP 0.01uF 10%	25V	C1504	1-162-960-11	CERAMIC CHIP 220PF 10%	50V
C150	1-162-970-11	CERAMIC CHIP 0.01uF 10%	25V	C1505	1-162-970-11	CERAMIC CHIP 0.01uF 10%	25V
C151	1-162-970-11	CERAMIC CHIP 0.01uF 10%	25V	C1506	1-162-964-11	CERAMIC CHIP 0.001uF 10%	50V
C152	1-162-916-11	CERAMIC CHIP 12PF 5%	50V	C1507	1-107-826-11	CERAMIC CHIP 0.1uF 10%	16V
C153	1-162-916-11	CERAMIC CHIP 12PF 5%	50V	C1512	1-107-826-11	CERAMIC CHIP 0.1uF 10%	16V
C154	1-107-826-11	CERAMIC CHIP 0.1uF 10%	16V	C1513	1-107-826-11	CERAMIC CHIP 0.1uF 10%	16V
C155	1-107-826-11	CERAMIC CHIP 0.1uF 10%	16V	C4602	1-164-360-11	CERAMIC CHIP 0.1uF	16V
C156	1-162-970-11	CERAMIC CHIP 0.01uF 10%	25V	C4603	1-164-360-11	CERAMIC CHIP 0.1uF	16V
C160	1-162-970-11	CERAMIC CHIP 0.01uF 10%	25V	C4606	1-164-360-11	CERAMIC CHIP 0.1uF	16V
C168	1-107-826-11	CERAMIC CHIP 0.1uF 10%	16V	C4608	1-124-779-00	ELECT CHIP 10uF 20%	16V
C169	1-107-826-11	CERAMIC CHIP 0.1uF 10%	16V	C4622	1-162-927-11	CERAMIC CHIP 100PF 5%	50V
C172	1-162-970-11	CERAMIC CHIP 0.01uF 10%	25V	C4623	1-162-927-11	CERAMIC CHIP 100PF 5%	50V
C175	1-162-970-11	CERAMIC CHIP 0.01uF 10%	25V	C4626	1-162-970-11	CERAMIC CHIP 0.01uF 10%	25V
C179	1-107-826-11	CERAMIC CHIP 0.1uF 10%	16V	< CONNECTOR >			
C180	1-107-826-11	CERAMIC CHIP 0.1uF 10%	16V	CN101	1-815-763-32	CONNECTOR, FFC/FPC 24P	
C181	1-107-826-11	CERAMIC CHIP 0.1uF 10%	16V	CN105	1-770-470-21	PIN, CONNECTOR (PC BOARD) 6P	
C183	1-165-908-11	CERAMIC CHIP 1uF 10%	10V	CN201	1-770-161-21	PIN, CONNECTOR (PC BOARD) 6P	
C188	1-164-315-11	CERAMIC CHIP 470PF 5%	50V	CN601	1-778-795-21	PIN, CONNECTOR (PC BOARD) 9P	
C190	1-128-995-21	ELECT CHIP 100uF 20%	10V	* CN1105	1-750-005-11	PIN, CONNECTOR (PC BOARD) 4P	
C191	1-107-826-11	CERAMIC CHIP 0.1uF 10%	16V	CN1106	1-784-861-51	CONNECTOR, FFC (LIF (NON-ZIF)) 9P	
C192	1-162-970-11	CERAMIC CHIP 0.01uF 10%	25V	CN4602	1-784-859-51	CONNECTOR, FFC (LIF (NON-ZIF)) 7P	
C193	1-127-715-11	CERAMIC CHIP 0.22uF 10%	16V	< DIODE >			
C195	1-127-715-11	CERAMIC CHIP 0.22uF 10%	16V	D001	6-500-848-01	DIODE MC2840-T112-1	
C197	1-107-826-11	CERAMIC CHIP 0.1uF 10%	16V	D002	6-500-848-01	DIODE MC2840-T112-1	
C198	1-165-908-11	CERAMIC CHIP 1uF 10%	10V	D003	6-500-848-01	DIODE MC2840-T112-1	
C199	1-162-968-11	CERAMIC CHIP 0.0047uF 10%	50V	D004	6-500-848-01	DIODE MC2840-T112-1	
				D005	6-500-848-01	DIODE MC2840-T112-1	

Ref. No.	Part No.	Description	Remark	Ref. No.	Part No.	Description	Remark
		< EARTH TERMINAL >		R156	1-216-809-11	METAL CHIP 100 5%	1/10W
ET001	1-780-482-11	EARTH TERMINAL		R204	1-216-822-11	METAL CHIP 1.2K 5%	1/10W
ET002	1-780-482-11	EARTH TERMINAL		R205	1-216-833-11	METAL CHIP 10K 5%	1/10W
ET003	1-780-482-11	EARTH TERMINAL		R206	1-216-833-11	METAL CHIP 10K 5%	1/10W
ET004	1-780-482-11	EARTH TERMINAL		R207	1-216-826-11	METAL CHIP 2.7K 5%	1/10W
		< FERRITE BEAD >		R208	1-216-839-11	METAL CHIP 33K 5%	1/10W
FB108	1-469-324-21	FERRITE, EMI (SMD) (2012)		R209	1-216-839-11	METAL CHIP 33K 5%	1/10W
FB603	1-469-324-21	FERRITE, EMI (SMD) (2012)		R210	1-216-841-11	METAL CHIP 47K 5%	1/10W
FB607	1-469-324-21	FERRITE, EMI (SMD) (2012)		R212	1-216-833-11	METAL CHIP 10K 5%	1/10W
FB1264	1-469-118-21	FERRITE, EMI (SMD) (1608)		R213	1-218-867-11	METAL CHIP 6.8K 0.5%	1/10W
FB1265	1-469-118-21	FERRITE, EMI (SMD) (1608)		R214	1-216-835-11	METAL CHIP 15K 5%	1/10W
FB1266	1-469-118-21	FERRITE, EMI (SMD) (1608)		R215	1-216-834-11	METAL CHIP 12K 5%	1/10W
FB1267	1-469-118-21	FERRITE, EMI (SMD) (1608)		R216	1-216-834-11	METAL CHIP 12K 5%	1/10W
FB1268	1-469-118-21	FERRITE, EMI (SMD) (1608)		R219	1-216-838-11	METAL CHIP 27K 5%	1/10W
R1114	1-500-903-21	EMI FERRITE (SMD)		R220	1-216-821-11	METAL CHIP 1K 5%	1/10W
		< FLUORESCENT INDICATOR TUBE >		R221	1-218-889-11	METAL CHIP 56K 0.5%	1/10W
FL603	1-234-494-21	FILTER, EMI REMOVAL (SMD)		R223	1-218-895-11	METAL CHIP 100K 0.5%	1/10W
		< IC >		R224	1-216-833-11	METAL CHIP 10K 5%	1/10W
IC101	6-713-721-01	IC CXD9968R		R225	1-218-895-11	METAL CHIP 100K 0.5%	1/10W
IC102	(Not supplied)	IC MX25L1605DM2I-12G		R226	1-218-889-11	METAL CHIP 56K 0.5%	1/10W
IC104	6-713-754-01	IC W9864G6IH-6J-ER10		R230	1-218-893-11	METAL CHIP 82K 0.5%	1/10W
IC107	6-702-302-01	IC TK11133CSCL-G		R231	1-218-875-11	METAL CHIP 15K 0.5%	1/10W
IC111	6-706-838-01	IC MM1661JHBE		R232	1-218-877-11	METAL CHIP 18K 0.5%	1/10W
IC201	6-704-524-01	IC FAN8036L		R233	1-218-883-11	METAL CHIP 33K 0.5%	1/10W
IC4601	6-710-554-01	IC PCM1808PWR		R234	1-216-833-11	METAL CHIP 10K 5%	1/10W
IC4602	6-704-819-01	IC CS4335-KSZR		R246	1-216-829-11	METAL CHIP 4.7K 5%	1/10W
		< TRANSISTOR >		R247	1-216-821-11	METAL CHIP 1K 5%	1/10W
Q101	6-550-008-01	TRANSISTOR UM6K1N-TN		R256	1-216-833-11	METAL CHIP 10K 5%	1/10W
Q102	6-550-653-01	TRANSISTOR QST8TR		R521	1-216-833-11	METAL CHIP 10K 5%	1/10W
Q103	8-729-027-52	TRANSISTOR DTC124EKA-T146		R605	1-216-295-91	SHORT CHIP 0	
		< RESISTOR >		R606	1-216-295-91	SHORT CHIP 0	
R101	1-216-809-11	METAL CHIP 100 5%	1/10W	R608	1-216-295-91	SHORT CHIP 0	
R102	1-216-864-11	SHORT CHIP 0		R630	1-216-295-91	SHORT CHIP 0	
R103	1-218-864-11	METAL CHIP 5.1K 0.5%	1/10W	R1101	1-218-841-11	METAL CHIP 560 0.5%	1/10W
R107	1-216-833-11	METAL CHIP 10K 5%	1/10W	R1110	1-216-826-11	METAL CHIP 2.7K 5%	1/10W
R108	1-216-857-11	METAL CHIP 1M 5%	1/10W	R1121	1-216-864-11	SHORT CHIP 0	
R109	1-216-809-11	METAL CHIP 100 5%	1/10W	R1123	1-216-864-11	SHORT CHIP 0	
R110	1-216-841-11	METAL CHIP 47K 5%	1/10W	R1129	1-216-845-11	METAL CHIP 100K 5%	1/10W
R111	1-216-809-11	METAL CHIP 100 5%	1/10W	R1150	1-216-827-11	METAL CHIP 3.3K 5%	1/10W
R112	1-211-977-11	METAL CHIP 22 0.5%	1/10W	R1151	1-216-827-11	METAL CHIP 3.3K 5%	1/10W
R113	1-211-977-11	METAL CHIP 22 0.5%	1/10W	R1152	1-216-827-11	METAL CHIP 3.3K 5%	1/10W
R114	1-216-845-11	METAL CHIP 100K 5%	1/10W	R1168	1-218-835-11	METAL CHIP 330 0.5%	1/10W
R115	1-211-977-11	METAL CHIP 22 0.5%	1/10W	R1177	1-216-864-11	SHORT CHIP 0	
R116	1-216-821-11	METAL CHIP 1K 5%	1/10W	R1178	1-216-821-11	METAL CHIP 1K 5%	1/10W
R117	1-216-841-11	METAL CHIP 47K 5%	1/10W	R1184	1-216-809-11	METAL CHIP 100 5%	1/10W
R118	1-216-801-11	METAL CHIP 22 5%	1/10W	R1191	1-216-864-11	SHORT CHIP 0	
R120	1-216-801-11	METAL CHIP 22 5%	1/10W	R1192	1-216-864-11	SHORT CHIP 0	
R121	1-216-801-11	METAL CHIP 22 5%	1/10W	R1193	1-216-864-11	SHORT CHIP 0	
R122	1-216-833-11	METAL CHIP 10K 5%	1/10W	R1194	1-216-864-11	SHORT CHIP 0	
R123	1-216-809-11	METAL CHIP 100 5%	1/10W	R1248	1-216-295-91	SHORT CHIP 0	
R124	1-216-841-11	METAL CHIP 47K 5%	1/10W	R1249	1-216-821-11	METAL CHIP 1K 5%	1/10W
R125	1-216-833-11	METAL CHIP 10K 5%	1/10W	R1250	1-216-295-91	SHORT CHIP 0	
R133	1-216-864-11	SHORT CHIP 0		R1252	1-216-295-91	SHORT CHIP 0	
R136	1-216-835-11	METAL CHIP 15K 5%	1/10W	R1255	1-216-295-91	SHORT CHIP 0	
R142	1-216-845-11	METAL CHIP 100K 5%	1/10W	R1256	1-216-295-91	SHORT CHIP 0	
				R1261	1-216-833-11	METAL CHIP 10K 5%	1/10W
				R1262	1-216-833-11	METAL CHIP 10K 5%	1/10W
				R1263	1-216-864-11	SHORT CHIP 0	
				R1269	1-216-809-11	METAL CHIP 100 5%	1/10W
				R1276	1-216-864-11	SHORT CHIP 0	

# HCD-GTR6/GTR6B/GTR7/GTR8/GTR8B

**DMB19** **DRIVER** **FRONT**

Ref. No.	Part No.	Description	Quantity	Value	Remark
R1277	1-216-809-11	METAL CHIP	100	5%	1/10W
R1278	1-216-833-11	METAL CHIP	10K	5%	1/10W
R1279	1-216-833-11	METAL CHIP	10K	5%	1/10W
R1280	1-216-864-11	SHORT CHIP	0		
R1281	1-216-864-11	SHORT CHIP	0		
R1282	1-216-864-11	SHORT CHIP	0		
R1283	1-216-864-11	SHORT CHIP	0		
R4601	1-216-809-11	METAL CHIP	100	5%	1/10W
R4602	1-216-809-11	METAL CHIP	100	5%	1/10W
R4605	1-469-112-21	FERRITE, EMI (SMD) (1608)			
R4606	1-216-801-11	METAL CHIP	22	5%	1/10W
R4608	1-216-864-11	SHORT CHIP	0		
R4609	1-216-864-11	SHORT CHIP	0		
R4611	1-216-864-11	SHORT CHIP	0		
R4833	1-216-864-11	SHORT CHIP	0		
R4834	1-216-864-11	SHORT CHIP	0		
R4835	1-216-295-91	SHORT CHIP	0		
R4837	1-216-864-11	SHORT CHIP	0		
R4838	1-216-864-11	SHORT CHIP	0		
< COMPOSITION CIRCUIT BLOCK >					
RB105	1-234-400-21	CONDUCTOR, NETWORK (1005X4)			
RB106	1-234-400-21	CONDUCTOR, NETWORK (1005X4)			
RB107	1-234-400-21	CONDUCTOR, NETWORK (1005X4)			
RB108	1-234-400-21	CONDUCTOR, NETWORK (1005X4)			
RB111	1-234-400-21	CONDUCTOR, NETWORK (1005X4)			
RB112	1-234-400-21	CONDUCTOR, NETWORK (1005X4)			
RB113	1-234-400-21	CONDUCTOR, NETWORK (1005X4)			
RB114	1-234-400-21	CONDUCTOR, NETWORK (1005X4)			
RB115	1-234-400-21	CONDUCTOR, NETWORK (1005X4)			
< VIBRATOR >					
X101	1-814-103-21	VIBRATOR, CRYSTAL			
*****					
A-1103-756-B	DRIVER BOARD, COMPLETE				
*****					
< CAPACITOR >					
C715	1-126-933-11	ELECT	100uF	20%	16V
C731	1-126-964-11	ELECT	10uF	20%	50V
C735	1-164-159-11	CERAMIC	0.1uF		50V
C736	1-164-159-11	CERAMIC	0.1uF		50V
C737	1-164-159-11	CERAMIC	0.1uF		50V
C741	1-114-708-41	CERAMIC	0.01uF	10%	50V
C751	1-114-708-41	CERAMIC	0.01uF	10%	50V
C752	1-164-159-11	CERAMIC	0.1uF		50V
< CONNECTOR >					
CN701	1-784-735-11	CONNECTOR, FFC 13P			
CN702	1-784-766-11	CONNECTOR, FFC 5P			
CN703	1-564-720-11	PIN, CONNECTOR (SMALL TYPE) 4P			
CN704	1-785-328-11	PIN, CONNECTOR (LIGHT ANGRE) 2P			
< DIODE >					
D701	8-719-921-42	DIODE MTZJ-5.1A			
D711	8-719-109-69	DIODE RD3.6ESB2			
< IC >					
IC701	8-759-598-69	IC BA6956AN			

Ref. No.	Part No.	Description	Quantity	Value	Remark
IC712	8-759-598-69	IC BA6956AN			
< TRANSISTOR >					
Q731	8-729-029-66	TRANSISTOR			DTC114ESA
< RESISTOR >					
R701	1-249-413-11	CARBON	470	5%	1/4W
R702	1-247-807-31	CARBON	100	5%	1/4W
R711	1-247-831-91	CARBON	1K	5%	1/4W
R712	1-247-847-91	CARBON	4.7K	5%	1/4W
R713	1-249-433-11	CARBON	22K	5%	1/4W
R721	1-247-847-91	CARBON	4.7K	5%	1/4W
R722	1-247-847-91	CARBON	4.7K	5%	1/4W
R723	1-247-847-91	CARBON	4.7K	5%	1/4W
R731	1-247-807-31	CARBON	100	5%	1/4W
R732	1-249-429-11	CARBON	10K	5%	1/4W
R733	1-249-417-11	CARBON	1K	5%	1/4W
R734	1-249-430-11	CARBON	12K	5%	1/4W
R736	1-249-412-11	CARBON	390	5%	1/4W
R751	1-247-847-91	CARBON	4.7K	5%	1/4W
*****					
FRONT BOARD					
*****					
< CAPACITOR >					
C1308	1-162-909-11	CERAMIC CHIP	4PF	0.25PF	50V
C1315	1-128-582-11	ELECT	10uF	20%	100V
C1318	1-100-155-91	CERAMIC CHIP	470PF	5%	100V
C1322	1-100-155-91	CERAMIC CHIP	470PF	5%	100V
C1324	1-162-909-11	CERAMIC CHIP	4PF	0.25PF	50V
C1336	1-127-812-11	ELECT (BLOCK)	3300uF	20%	63V
C1339	1-127-812-11	ELECT (BLOCK)	3300uF	20%	63V
C1344	1-126-963-11	ELECT	4.7uF	20%	50V
C1313	1-126-961-11	ELECT	2.2uF	20%	50V
C1314	1-104-658-91	ELECT	100uF	20%	10V
C1316	1-128-582-11	ELECT	10uF	20%	100V
C1319	1-164-730-11	CERAMIC CHIP	0.0012uF	10%	50V
C1320	1-126-947-11	ELECT	47uF	20%	35V
C1321	1-164-730-11	CERAMIC CHIP	0.0012uF	10%	50V
C1323	1-126-947-11	ELECT	47uF	20%	35V
C1325	1-126-963-11	ELECT	4.7uF	20%	50V
C1326	1-126-963-11	ELECT	4.7uF	20%	50V
C1332	1-130-777-00	MYLAR	0.1uF	5%	100V
C1333	1-130-777-00	MYLAR	0.1uF	5%	100V
C1334	1-127-815-11	ELECT (BLOCK)	3300uF	20%	100V
C1335	1-127-815-11	ELECT (BLOCK)	3300uF	20%	100V
C1337	1-130-777-00	MYLAR	0.1uF	5%	100V
C1338	1-130-777-00	MYLAR	0.1uF	5%	100V
C1340	1-115-339-11	CERAMIC CHIP	0.1uF	10%	50V
C1341	1-115-339-11	CERAMIC CHIP	0.1uF	10%	50V
C1342	1-115-339-11	CERAMIC CHIP	0.1uF	10%	50V
C1343	1-115-339-11	CERAMIC CHIP	0.1uF	10%	50V
< CONNECTOR >					
CN1300	1-770-828-41	CONNECTOR, BOARD TO BOARD 16P			
CN1302	1-573-825-11	CONNECTOR, BOARD TO BOARD 11P			
< DIODE >					
D1300	6-501-817-01	DIODE MA2J1110GLS0 (GTR7/GTR8/GTR8B)			

Ref. No.	Part No.	Description	Remark	Ref. No.	Part No.	Description	Remark
D1304	6-501-175-01	DIODE UDZW-TE17-11B (GTR7/GTR8/GTR8B)		R1333	1-216-822-11	METAL CHIP 1.2K 5%	1/10W (GTR7:MX)
D1304	6-501-767-01	DIODE MAZ8120GLLS0 (GTR6/GTR6B)		R1334	1-216-842-11	METAL CHIP 56K 5%	1/10W
D1305	6-500-968-21	DIODE 30PRA20FC		R1335	1-216-818-11	METAL CHIP 560 5%	1/10W (GTR6/GTR6B)
D1306	6-501-175-01	DIODE UDZW-TE17-11B (GTR7/GTR8/GTR8B)		R1335	1-216-819-11	METAL CHIP 680 5%	1/10W (GTR8/GTR8B)
D1306	6-501-767-01	DIODE MAZ8120GLLS0 (GTR6/GTR6B)		R1335	1-216-820-11	METAL CHIP 820 5%	1/10W (GTR7 EXCEPT MX)
D1307	6-500-968-21	DIODE 30PRA20FC		R1335	1-216-822-11	METAL CHIP 1.2K 5%	1/10W (GTR7:MX)
D1302	6-501-817-01	DIODE MA2J1110GLSO		R1336	1-216-839-11	METAL CHIP 33K 5%	1/10W (GTR6/GTR6B)
D1308	6-501-817-01	DIODE MA2J1110GLSO		R1336	1-216-840-11	METAL CHIP 39K 5%	1/10W (GTR7/GTR8/GTR8B)
D1309	6-500-334-01	DIODE MC2836-T112-1		R1337	1-216-842-11	METAL CHIP 56K 5%	1/10W
D1310	6-501-754-01	DIODE MAZ8091G0LS0		R1338	1-216-821-11	METAL CHIP 1K 5%	1/10W
D1313	8-719-073-32	DIODE D25XB60		R1339	1-216-839-11	METAL CHIP 33K 5%	1/10W (GTR6/GTR6B)
D1314	8-719-073-32	DIODE D25XB60		R1339	1-216-840-11	METAL CHIP 39K 5%	1/10W (GTR7/GTR8/GTR8B)
D1315	6-500-335-01	DIODE MC2838-T112-1		R1341	1-216-821-11	METAL CHIP 1K 5%	1/10W
		< IC >		R1342	1-216-821-11	METAL CHIP 1K 5%	1/10W
IC1300	6-713-774-01	IC STK412-770-E (GTR6/GTR6B)		R1347	1-216-840-11	METAL CHIP 39K 5%	1/10W
IC1301	6-713-787-01	IC STK412-750-E (GTR7/GTR8/GTR8B)		R1374	1-234-798-11	ENCAPSULATED COMPONENT	
		< JACK >		R1375	1-234-798-11	ENCAPSULATED COMPONENT	
JK1300	1-820-067-11	TERMINAL BOARD (SURROUND SPEAKER)		R1380	1-216-821-11	METAL CHIP 1K 5%	1/10W
JK1301	1-820-067-11	TERMINAL BOARD (FRONT SPEAKER)		R1381	1-216-839-11	METAL CHIP 33K 5%	1/10W
		< JUMPER RESISTOR >		R1394	1-246-024-21	METAL CHIP 150 5%	1/2W (GTR7/GTR8/GTR8B)
JR1300	1-216-864-11	SHORT CHIP 0 (GTR7/GTR8/GTR8B)		R1306	1-216-821-11	METAL CHIP 1K 5%	1/10W
		< TRANSISTOR >		R1313	1-215-872-11	METAL OXIDE 3.3K 5%	1W
Q1300	8-729-620-07	TRANSISTOR 2SC3052EF-T1-LEF (GTR7/GTR8/GTR8B)		R1314	1-215-872-11	METAL OXIDE 3.3K 5%	1W
Q1315	8-729-027-38	TRANSISTOR DTA144EKA-T146		R1315	1-217-637-55	FUSIBLE 1 5%	1/4W
Q1316	8-729-620-07	TRANSISTOR 2SC3052EF-T1-LEF		R1317	1-216-842-11	METAL CHIP 56K 5%	1/10W
Q1301	8-729-620-07	TRANSISTOR 2SC3052EF-T1-LEF		R1319	1-216-843-11	METAL CHIP 68K 5%	1/10W
Q1302	8-729-620-07	TRANSISTOR 2SC3052EF-T1-LEF		R1320	1-245-711-31	CARBON 10 5%	1/2W
Q1303	8-729-620-07	TRANSISTOR 2SC3052EF-T1-LEF		R1321	1-245-711-31	CARBON 10 5%	1/2W
Q1304	8-729-620-07	TRANSISTOR 2SC3052EF-T1-LEF		R1323	1-216-845-11	METAL CHIP 100K 5%	1/10W
Q1305	6-551-696-01	TRANSISTOR ISA1235AC1TP-1EF		R1324	1-216-829-11	METAL CHIP 4.7K 5%	1/10W
Q1306	8-729-620-07	TRANSISTOR 2SC3052EF-T1-LEF		R1325	1-216-845-11	METAL CHIP 100K 5%	1/10W
Q1307	8-729-620-07	TRANSISTOR 2SC3052EF-T1-LEF		R1328	1-216-841-11	METAL CHIP 47K 5%	1/10W
Q1308	8-729-620-07	TRANSISTOR 2SC3052EF-T1-LEF		R1329	1-216-837-11	METAL CHIP 22K 5%	1/10W
Q1309	8-729-620-07	TRANSISTOR 2SC3052EF-T1-LEF		R1330	1-216-821-11	METAL CHIP 1K 5%	1/10W
Q1310	8-729-620-07	TRANSISTOR 2SC3052EF-T1-LEF		R1331	1-245-605-55	FUSIBLE 100 5%	1/4W
		< RESISTOR >		R1340	1-216-845-11	METAL CHIP 100K 5%	1/10W
R1301	1-216-821-11	METAL CHIP 1K 5%	1/10W (GTR7/GTR8/GTR8B)	R1343	1-216-845-11	METAL CHIP 100K 5%	1/10W
R1307	1-216-821-11	METAL CHIP 1K 5%	1/10W	R1344	1-216-845-11	METAL CHIP 100K 5%	1/10W
R1316	1-245-605-55	FUSIBLE 100 5%	1/4W	R1345	1-216-825-11	METAL CHIP 2.2K 5%	1/10W
R1318	1-216-842-11	METAL CHIP 56K 5%	1/10W	R1365	1-216-849-11	METAL CHIP 220K 5%	1/10W
R1322	1-216-821-11	METAL CHIP 1K 5%	1/10W	R1367	1-216-849-11	METAL CHIP 220K 5%	1/10W
R1326	1-216-864-11	SHORT CHIP 0		R1370	1-216-845-11	METAL CHIP 100K 5%	1/10W
R1327	1-216-837-11	METAL CHIP 22K 5%	1/10W (GTR6/GTR6B)	R1372	1-216-845-11	METAL CHIP 100K 5%	1/10W
R1327	1-216-838-11	METAL CHIP 27K 5%	1/10W (GTR7/GTR8/GTR8B)	R1395	1-246-024-21	METAL CHIP 150 5%	1/2W
R1332	1-216-842-11	METAL CHIP 56K 5%	1/10W	R1396	1-216-829-11	METAL CHIP 4.7K 5%	1/10W
R1333	1-216-818-11	METAL CHIP 560 5%	1/10W (GTR6/GTR6B)	R1397	1-216-829-11	METAL CHIP 4.7K 5%	1/10W
R1333	1-216-819-11	METAL CHIP 680 5%	1/10W (GTR8/GTR8B)			< RELAY >	
R1333	1-216-820-11	METAL CHIP 820 5%	1/10W (GTR7 EXCEPT MX)	RY1300	1-755-307-21	RELAY (GTR7/GTR8/GTR8B)	
				RY1300	1-755-308-21	RELAY (GTR7/GTR8/GTR8B)	
				RY1301	1-755-307-21	RELAY	

# HCD-GTR6/GTR6B/GTR7/GTR8/GTR8B

Ver. 1.2

**HEADPHONE** **HUB**

Ref. No.	Part No.	Description	Remark
< THERMISTOR >			
TH1300	1-807-796-11	THERMISTOR	
TH1301	1-804-045-11	THERMISTOR	
*****			
HEADPHONE BOARD *****			
< CAPACITOR >			
C1060	1-164-156-11	CERAMIC CHIP 0.1uF	25V
C1061	1-162-964-11	CERAMIC CHIP 0.001uF 10%	50V
C1062	1-162-964-11	CERAMIC CHIP 0.001uF 10%	50V
< DIODE >			
D1050	6-500-848-01	DIODE MC2840-T112-1	
< FERRITE BEAD >			
FB1001	1-469-116-21	FERRITE, EMI (SMD) (1608)	
FB1002	1-469-116-21	FERRITE, EMI (SMD) (1608)	
FB1003	1-469-116-21	FERRITE, EMI (SMD) (1608)	
< JACK >			
J1005	1-794-702-11	JACK, HEADPHONE (PHONE)	
*****			
HUB BOARD *****			
< CAPACITOR >			
C1500	1-100-597-91	CERAMIC CHIP 0.1uF 10%	25V
C1501	1-165-989-11	CERAMIC CHIP 10uF 10%	6.3V
C1502	1-100-597-91	CERAMIC CHIP 0.1uF 10%	25V
C1503	1-162-915-11	CERAMIC CHIP 10PF 0.5PF	50V
C1504	1-162-919-11	CERAMIC CHIP 22PF 5%	50V
C1505	1-162-970-11	CERAMIC CHIP 0.01uF 10%	25V
C1506	1-162-970-11	CERAMIC CHIP 0.01uF 10%	25V
C1507	1-100-597-91	CERAMIC CHIP 0.1uF 10%	25V
C1508	1-165-989-11	CERAMIC CHIP 10uF 10%	6.3V
C1510	1-100-597-91	CERAMIC CHIP 0.1uF 10%	25V
C1511	1-162-970-11	CERAMIC CHIP 0.01uF 10%	25V
C1512	1-165-989-11	CERAMIC CHIP 10uF 10%	6.3V
C1513	1-162-970-11	CERAMIC CHIP 0.01uF 10%	25V
C1514	1-165-989-11	CERAMIC CHIP 10uF 10%	6.3V
C1515	1-162-970-11	CERAMIC CHIP 0.01uF 10%	25V
C1516	1-162-970-11	CERAMIC CHIP 0.01uF 10%	25V
C1517	1-100-597-91	CERAMIC CHIP 0.1uF 10%	25V
C1519	1-162-970-11	CERAMIC CHIP 0.01uF 10%	25V
C1520	1-126-204-11	ELECT CHIP 47uF 20%	16V
C1522	1-100-597-91	CERAMIC CHIP 0.1uF 10%	25V
C1523	1-100-597-91	CERAMIC CHIP 0.1uF 10%	25V
C1524	1-100-597-91	CERAMIC CHIP 0.1uF 10%	25V
C1525	1-162-970-11	CERAMIC CHIP 0.01uF 10%	25V
C1526	1-162-970-11	CERAMIC CHIP 0.01uF 10%	25V
< CONNECTOR >			
CN1501	1-774-729-21	PIN, CONNECTOR (PC BOARD) 10P	
CN1503	1-779-993-11	PIN, CONNECTOR (PWB) 5P	
CN1554	1-820-121-41	CONNECTOR, FFC/FPC 23P	
CN1555	1-820-112-51	CONNECTOR, FFC/FPC 9P	
CN1556	1-785-466-51	CONNECTOR, FFC/FPC 7P	

Ref. No.	Part No.	Description	Remark
< FERRITE BEAD >			
FB1500	1-216-295-91	SHORT CHIP 0	
FB1501	1-216-295-91	SHORT CHIP 0	
FB1502	1-216-295-91	SHORT CHIP 0	
FB1503	1-216-295-91	SHORT CHIP 0	
< IC >			
IC1500	8-759-338-95	IC NJM2903V (TE2)	
IC1501	6-714-034-01	IC USB2512A-AEZG	
< RESISTOR >			
R1500	1-216-809-11	METAL CHIP 100	5% 1/10W
R1501	1-216-833-11	METAL CHIP 10K	5% 1/10W
R1502	1-216-833-11	METAL CHIP 10K	5% 1/10W
R1503	1-216-815-11	METAL CHIP 330	5% 1/10W
R1504	1-218-446-11	METAL CHIP 1	5% 1/10W
R1505	1-218-446-11	METAL CHIP 1	5% 1/10W
R1506	1-218-446-11	METAL CHIP 1	5% 1/10W
R1507	1-218-446-11	METAL CHIP 1	5% 1/10W
R1508	1-218-446-11	METAL CHIP 1	5% 1/10W
R1509	1-218-446-11	METAL CHIP 1	5% 1/10W
R1510	1-218-446-11	METAL CHIP 1	5% 1/10W
R1511	1-218-446-11	METAL CHIP 1	5% 1/10W
R1512	1-218-446-11	METAL CHIP 1	5% 1/10W
R1513	1-218-446-11	METAL CHIP 1	5% 1/10W
R1514	1-216-833-11	METAL CHIP 10K	5% 1/10W
R1515	1-216-833-11	METAL CHIP 10K	5% 1/10W
R1516	1-216-815-11	METAL CHIP 330	5% 1/10W
R1517	1-218-446-11	METAL CHIP 1	5% 1/10W
R1518	1-218-446-11	METAL CHIP 1	5% 1/10W
R1519	1-218-446-11	METAL CHIP 1	5% 1/10W
R1520	1-218-446-11	METAL CHIP 1	5% 1/10W
R1521	1-218-446-11	METAL CHIP 1	5% 1/10W
R1522	1-218-446-11	METAL CHIP 1	5% 1/10W
R1523	1-218-446-11	METAL CHIP 1	5% 1/10W
R1524	1-218-446-11	METAL CHIP 1	5% 1/10W
R1525	1-218-446-11	METAL CHIP 1	5% 1/10W
R1526	1-218-446-11	METAL CHIP 1	5% 1/10W
R1527	1-216-809-11	METAL CHIP 100	5% 1/10W
R1528	1-216-845-11	METAL CHIP 100K	5% 1/10W
R1530	1-216-857-11	METAL CHIP 1M	5% 1/10W
R1533	1-216-845-11	METAL CHIP 100K	5% 1/10W
R1535	1-162-964-11	CERAMIC CHIP 0.001uF	10% 50V
R1537	1-216-845-11	METAL CHIP 100K	5% 1/10W
R1538	1-216-845-11	METAL CHIP 100K	5% 1/10W
R1540	1-216-845-11	METAL CHIP 100K	5% 1/10W
R1541	1-216-809-11	METAL CHIP 100	5% 1/10W
R1543	1-216-833-11	METAL CHIP 10K	5% 1/10W
R1544	1-216-833-11	METAL CHIP 10K	5% 1/10W
R1546	1-216-809-11	METAL CHIP 100	5% 1/10W
R1547	1-216-834-11	METAL CHIP 12K	5% 1/10W
R1549	1-216-833-11	METAL CHIP 10K	5% 1/10W
R1550	1-216-833-11	METAL CHIP 10K	5% 1/10W
< VIBRATOR >			
X1500	1-760-613-21	VIBRATOR, CRYSTAL (24 MHZ)	
*****			

Ref. No.	Part No.	Description	Remark	Ref. No.	Part No.	Description	Remark
	A-1702-138-A	MAIN BOARD, COMPLETE (GTR8B: E3)		C129	1-126-961-11	ELECT 2.2uF 20%	50V
	A-1702-161-A	MAIN BOARD, COMPLETE (GTR8: E2)		C131	1-126-964-11	ELECT 10uF 20%	50V
	A-1702-168-A	MAIN BOARD, COMPLETE (GTR6B: E3)					
	A-1724-710-A	MAIN BOARD, COMPLETE (GTR8: E51, AR)		C132	1-136-161-00	FILM 0.047uF 5%	50V
	A-1724-712-A	MAIN BOARD, COMPLETE (GTR8B: AUS)		C133	1-164-227-11	CERAMIC CHIP 0.022uF 10%	25V
	A-1724-715-A	MAIN BOARD, COMPLETE (GTR8:MX)		C134	1-162-970-11	CERAMIC CHIP 0.01uF 10%	25V
	A-1724-746-A	MAIN BOARD, COMPLETE (GTR7: E2)		C135	1-164-173-11	CERAMIC CHIP 0.0039uF 10%	50V
	A-1724-748-A	MAIN BOARD, COMPLETE (GTR7: E51, AR)					(GTR7/GTR8/GTR8B)
	A-1724-750-A	MAIN BOARD, COMPLETE (GTR7:MX)		C135	1-164-174-11	CERAMIC CHIP 0.0082uF 10%	25V
	A-1724-752-A	MAIN BOARD, COMPLETE (GTR6: E2)					(GTR6/GTR6B)
	A-1724-754-A	MAIN BOARD, COMPLETE (GTR6B: AUS)					
	A-1724-757-A	MAIN BOARD, COMPLETE (GTR6: E51, AR)		C137	1-126-964-11	ELECT 10uF 20%	50V
		*****		C141	1-117-720-11	CERAMIC CHIP 4.7uF	10V
	7-685-645-79	SCREW +BVTP 3X6 TYPE2 IT-3		C142	1-117-720-11	CERAMIC CHIP 4.7uF	10V
	7-685-646-79	SCREW +BVTP 3X8 TYPE2 IT-3		C143	1-117-720-11	CERAMIC CHIP 4.7uF	10V
		< CAPACITOR >		C144	1-126-964-11	ELECT 10uF 20%	50V
C001	1-162-968-11	CERAMIC CHIP 0.0047uF 10%	50V (GTR6B/GTR8B)	C145	1-117-720-11	CERAMIC CHIP 4.7uF	10V
C002	1-126-916-11	ELECT 1000uF 20%	6.3V	C146	1-117-720-11	CERAMIC CHIP 4.7uF	10V
C003	1-126-964-11	ELECT 10uF 20%	50V	C147	1-126-959-11	ELECT 0.47uF 20%	50V
C004	1-128-934-11	CERAMIC CHIP 0.33uF 20%	10V	C148	1-104-658-91	ELECT 100uF 20%	10V
C005	1-126-964-11	ELECT 10uF 20%	50V	C149	1-126-947-11	ELECT 47uF 20%	35V
C006	1-126-964-11	ELECT 10uF 20%	50V	C150	1-100-597-91	CERAMIC CHIP 0.1uF 10%	25V
C007	1-164-156-11	CERAMIC CHIP 0.1uF	25V	C151	1-100-597-91	CERAMIC CHIP 0.1uF 10%	25V
C021	1-104-658-91	ELECT 100uF 20%	10V	C152	1-100-756-91	CERAMIC CHIP 0.047uF 10%	50V
C024	1-126-964-11	ELECT 10uF 20%	50V	C153	1-100-597-91	CERAMIC CHIP 0.1uF 10%	25V
C030	1-126-965-91	ELECT 22uF 20%	50V	C154	1-126-925-91	ELECT 470uF 20%	10V
C034	1-164-156-11	CERAMIC CHIP 0.1uF	25V	C155	1-162-967-11	CERAMIC CHIP 0.33uF	50V
C035	1-126-947-11	ELECT 47uF 20%	35V	C157	1-162-919-11	CERAMIC CHIP 22PF 5%	50V
C037	1-164-156-11	CERAMIC CHIP 0.1uF	25V	C177	1-137-190-91	FILM 0.22uF 5%	50V
C041	1-164-156-11	CERAMIC CHIP 0.1uF	25V (GTR7/GTR8/GTR8B)	C177	1-136-170-00	FILM 0.27uF 5%	50V
C042	1-126-947-11	ELECT 47uF 20%	35V (GTR7/GTR8/GTR8B)	C178	1-137-189-11	FILM 0.18uF 5%	50V
C043	1-164-156-11	CERAMIC CHIP 0.1uF	25V (GTR7/GTR8/GTR8B)	C178	1-137-190-91	FILM 0.22uF 5%	50V
C050	1-100-597-91	CERAMIC CHIP 0.1uF 10%	25V	C179	1-126-961-11	ELECT 2.2uF 20%	50V
C051	1-126-925-91	ELECT 470uF 20%	10V	C180	1-126-959-11	ELECT 0.47uF 20%	50V
C053	1-126-947-11	ELECT 47uF 20%	35V	C181	1-126-964-11	ELECT 10uF 20%	50V
C081	1-165-733-31	ELECT 100uF 20%	25V	C182	1-136-161-00	FILM 0.047uF 5%	50V
C082	1-100-597-91	CERAMIC CHIP 0.1uF 10%	25V	C183	1-164-227-11	CERAMIC CHIP 0.022uF 10%	25V
C083	1-128-942-31	ELECT 1000uF 20%	6.3V	C184	1-162-970-11	CERAMIC CHIP 0.01uF 10%	25V
C090	1-165-733-31	ELECT 100uF 20%	25V	C185	1-164-173-11	CERAMIC CHIP 0.0039uF 10%	50V
C091	1-100-597-91	CERAMIC CHIP 0.1uF 10%	25V				(GTR7/GTR8/GTR8B)
C092	1-128-950-21	ELECT 1000uF 20%	16V	C185	1-164-174-11	CERAMIC CHIP 0.0082uF 10%	25V
C095	1-165-733-31	ELECT 100uF 20%	25V				(GTR6/GTR6B)
C096	1-100-597-91	CERAMIC CHIP 0.1uF 10%	25V	C187	1-126-964-11	ELECT 10uF 20%	50V
C097	1-128-942-31	ELECT 1000uF 20%	6.3V	C191	1-117-720-11	CERAMIC CHIP 4.7uF	10V
C102	1-126-963-11	ELECT 4.7uF 20%	50V	C192	1-117-720-11	CERAMIC CHIP 4.7uF	10V
C105	1-162-967-11	CERAMIC CHIP 0.33uF	50V	C193	1-117-720-11	CERAMIC CHIP 4.7uF	10V
C107	1-162-919-11	CERAMIC CHIP 22PF 5%	50V	C194	1-126-964-11	ELECT 10uF 20%	50V
C109	1-126-964-11	ELECT 10uF 20%	50V	C195	1-117-720-11	CERAMIC CHIP 4.7uF	10V
C120	1-100-597-91	CERAMIC CHIP 0.1uF 10%	25V	C201	1-126-961-11	ELECT 2.2uF 20%	50V
C124	1-126-960-11	ELECT 1uF 20%	50V	C212	1-164-505-11	CERAMIC CHIP 2.2uF	16V
C127	1-137-190-91	FILM 0.22uF 5%	50V (GTR7/GTR8/GTR8B)	C213	1-126-961-11	ELECT 2.2uF	50V
C127	1-136-170-00	FILM 0.27uF 5%	50V (GTR6/GTR6B)	C214	1-126-935-11	ELECT 470uF 20%	16V
C128	1-137-189-11	FILM 0.18uF 5%	50V (GTR6/GTR6B)	C217	1-126-961-11	ELECT 2.2uF 20%	50V
C128	1-137-190-91	FILM 0.22uF 5%	50V (GTR7/GTR8/GTR8B)				(GTR7/GTR8/GTR8B)
				C218	1-126-947-11	ELECT 47uF 20%	35V
				C220	1-126-947-11	ELECT 47uF 20%	35V
				C222	1-162-923-11	CERAMIC CHIP 47PF 5%	50V
				C223	1-162-919-11	CERAMIC CHIP 22PF 5%	50V
				C227	1-126-964-11	ELECT 10uF 20%	50V

# HCD-GTR6/GTR6B/GTR7/GTR8/GTR8B

Ver. 1.2

MAIN

Ref. No.	Part No.	Description	Remark		
C229	1-126-964-11	ELECT	10uF	20%	50V
C231	1-136-162-00	FILM	0.056uF	5%	50V
C234	1-110-563-11	CERAMIC CHIP	0.068uF	10%	16V
C236	1-131-664-91	CERAMIC CHIP	0.15uF	10%	10V
C238	1-137-189-11	FILM	0.18uF	5%	50V
C239	1-131-664-91	CERAMIC CHIP	0.15uF	10%	10V
C248	1-137-189-11	FILM	0.18uF	5%	50V
C258	1-126-947-11	ELECT	47uF	20%	35V
C267	1-126-961-11	ELECT	2.2uF	20%	50V
C270	1-126-947-11	ELECT	47uF	20%	35V
C272	1-162-923-11	CERAMIC CHIP	47PF	5%	50V
C273	1-162-919-11	CERAMIC CHIP	22PF	5%	50V
C275	1-100-597-91	CERAMIC CHIP	0.1uF	10%	25V
C276	1-126-925-91	ELECT	470uF	20%	10V
C277	1-126-964-11	ELECT	10uF	20%	50V
C279	1-126-964-11	ELECT	10uF	20%	50V
C281	1-136-162-00	FILM	0.056uF	5%	50V
C284	1-110-563-11	CERAMIC CHIP	0.068uF	10%	16V
C286	1-131-664-91	CERAMIC CHIP	0.15uF	10%	10V
C289	1-131-664-91	CERAMIC CHIP	0.15uF	10%	10V
C290	1-104-658-91	ELECT	100uF	20%	10V
C291	1-126-925-91	ELECT	470uF	20%	10V
C292	1-162-964-11	CERAMIC CHIP	0.001uF	10%	50V
C294	1-100-597-91	CERAMIC CHIP	0.1uF	10%	25V
C300	1-164-315-11	CERAMIC CHIP	470PF	5%	50V
C301	1-164-315-11	CERAMIC CHIP	470PF	5%	50V
C302	1-136-153-00	FILM	0.01uF	5%	50V
C303	1-162-964-11	CERAMIC CHIP	0.001uF	10%	50V
C304	1-162-964-11	CERAMIC CHIP	0.001uF	10%	50V
C306	1-126-947-11	ELECT	47uF	20%	35V
C313	1-162-962-11	CERAMIC CHIP	470PF	10%	50V
C314	1-162-962-11	CERAMIC CHIP	470PF	10%	50V
C315	1-162-923-11	CERAMIC CHIP	47PF	5%	50V
C316	1-162-923-11	CERAMIC CHIP	47PF	5%	50V
C317	1-126-965-91	ELECT	22uF	20%	50V
C318	1-126-965-91	ELECT	22uF	20%	50V

Ref. No.	Part No.	Description	Remark		
C323	1-162-969-11	CERAMIC CHIP	0.0068uF	10%	25V
C324	1-162-969-11	CERAMIC CHIP	0.0068uF	10%	25V
C327	1-162-960-11	CERAMIC CHIP	220PF	10%	50V
C328	1-162-960-11	CERAMIC CHIP	220PF	10%	50V
C329	1-131-690-31	FILM	0.068uF	5%	50V
C330	1-131-690-31	FILM	0.068uF	5%	50V
C350	1-126-934-11	ELECT	220uF	20%	16V
C351	1-126-923-91	ELECT	220uF	20%	10V
C352	1-107-826-11	CERAMIC CHIP	0.1uF	10%	16V
C353	1-107-826-11	CERAMIC CHIP	0.1uF	10%	16V
C355	1-162-970-11	CERAMIC CHIP	0.01uF	10%	25V
C356	1-126-964-11	ELECT	10uF	20%	50V
C401	1-117-720-11	CERAMIC CHIP	4.7uF		10V
C402	1-117-720-11	CERAMIC CHIP	4.7uF		10V
C403	1-162-923-11	CERAMIC CHIP	47PF	5%	50V
C404	1-162-923-11	CERAMIC CHIP	47PF	5%	50V
C405	1-164-218-11	CERAMIC CHIP	180PF	5%	50V
C406	1-164-218-11	CERAMIC CHIP	180PF	5%	50V
C407	1-100-831-91	CERAMIC CHIP	0.001uF	2%	50V
C408	1-162-969-11	CERAMIC CHIP	0.0068uF	10%	25V
C409	1-126-964-11	ELECT	10uF	20%	50V
C410	1-126-964-11	ELECT	10uF	20%	50V
C411	1-162-910-11	CERAMIC CHIP	5PF	0.25PF	50V
C412	1-162-910-11	CERAMIC CHIP	5PF	0.25PF	50V
C413	1-162-928-11	CERAMIC CHIP	120PF	5%	50V
C414	1-162-928-11	CERAMIC CHIP	120PF	5%	50V
C416	1-162-968-11	CERAMIC CHIP	0.0047uF	10%	50V
C417	1-162-968-11	CERAMIC CHIP	0.0047uF	10%	50V
C418	1-162-968-11	CERAMIC CHIP	0.0047uF	10%	50V
C430	1-164-156-11	CERAMIC CHIP	0.1uF		25V
C433	1-107-826-11	CERAMIC CHIP	0.1uF	10%	16V
C466	1-162-968-11	CERAMIC CHIP	0.0047uF	10%	50V
C510	1-162-919-11	CERAMIC CHIP	22PF	5%	50V



Ref. No.	Part No.	Description	Remark	Ref. No.	Part No.	Description	Remark
C511	1-162-919-11	CERAMIC CHIP 22PF 5%	50V	CN400	1-564-715-11	PIN, CONNECTOR (SMALL TYPE) 13P	
C512	1-100-756-91	CERAMIC CHIP 0.047uF 10%	50V	CN500	1-779-291-11	CONNECTOR, FFC (LIF (NON-ZIF)) 23P	
C516	1-100-597-91	CERAMIC CHIP 0.1uF 10%	25V	* CN550	1-774-876-21	CONNECTOR, BOARD TO BOARD 8P	(GTR8/GTR8B)
C537	1-162-919-11	CERAMIC CHIP 22PF 5%	50V				
C562	1-100-597-91	CERAMIC CHIP 0.1uF 10%	25V	CN551	1-766-600-21	CONNECTOR, BOARD TO BOARD 7P (GTR7)	
C587	1-164-361-11	CERAMIC CHIP 0.047uF	25V			< DIODE >	
C598	1-100-597-91	CERAMIC CHIP 0.1uF 10%	25V	D001	6-501-817-01	DIODE MA2J1110GLS0 (GTR6B/GTR8B)	
C602	1-100-597-91	CERAMIC CHIP 0.1uF 10%	25V	D003	6-501-817-01	DIODE MA2J1110GLS0	
C603	1-104-658-91	ELECT 100uF 20%	10V	D004	6-500-334-01	DIODE MC2836-T112-1	
C605	1-136-153-00	FILM 0.01uF 5%	50V	D005	6-501-722-01	DIODE MAZ8043GMLS0	
C606	1-136-153-00	FILM 0.01uF 5%	50V	D010	6-501-817-01	DIODE MA2J1110GLS0	
C608	1-128-548-11	ELECT 4700uF 20%	25V	D021	6-501-734-01	DIODE MAZ8056GMLS0	
C610	1-124-261-00	ELECT 10uF 20%	25V	D030	6-501-738-01	DIODE MAZ8062GMLS0	
C616	1-162-927-11	CERAMIC CHIP 100PF 5%	50V	D031	6-501-743-01	DIODE MAZ8068GMLS0	
C617	1-162-927-11	CERAMIC CHIP 100PF 5%	50V	D032	6-501-772-01	DIODE MAZ8130GMLS0 (GTR7/GTR8/GTR8B)	
C618	1-162-927-11	CERAMIC CHIP 100PF 5%	50V	D081	6-502-272-01	DIODE RB055L-40TE25	
C619	1-162-927-11	CERAMIC CHIP 100PF 5%	50V	D091	6-502-272-01	DIODE RB055L-40TE25	
C620	1-162-927-11	CERAMIC CHIP 100PF 5%	50V	D096	6-502-272-01	DIODE RB055L-40TE25	
C621	1-162-927-11	CERAMIC CHIP 100PF 5%	50V	D104	6-501-817-01	DIODE MA2J1110GLS0	
C623	1-162-970-11	CERAMIC CHIP 0.01uF 10%	25V	D116	6-500-848-01	DIODE MC2840-T112-1	
C624	1-162-970-11	CERAMIC CHIP 0.01uF 10%	25V	D166	6-501-817-01	DIODE MA2J1110GLS0	
C701	1-124-261-00	ELECT 10uF 20%	25V	D201	6-500-848-01	DIODE MC2840-T112-1	
C703	1-162-927-11	CERAMIC CHIP 100PF 5%	50V	D202	6-501-817-01	DIODE MA2J1110GLS0	
C704	1-162-927-11	CERAMIC CHIP 100PF 5%	50V	D290	6-501-817-01	DIODE MA2J1110GLS0	
C705	1-162-927-11	CERAMIC CHIP 100PF 5%	50V	D301	6-501-722-01	DIODE MAZ8043GMLS0 (GTR6B/GTR8B)	
C730	1-100-597-91	CERAMIC CHIP 0.1uF 10%	25V	D401	6-500-335-01	DIODE MC2838-T112-1 (GTR6B/GTR8B)	
			(GTR7/GTR8/GTR8B)	D571	6-500-335-01	DIODE MC2838-T112-1	
C747	1-126-960-11	ELECT 1uF 20%	50V	D600	6-500-360-01	DIODE D10XB20	
			(GTR7/GTR8/GTR8B)	D692	6-501-734-01	DIODE MAZ8056GMLS0	
C750	1-100-597-91	CERAMIC CHIP 0.1uF 10%	25V	D701	6-501-734-01	DIODE MAZ8056GMLS0	
C751	1-100-597-91	CERAMIC CHIP 0.1uF 10%	25V	D705	6-501-764-01	DIODE MAZ8110GMLS0	
C752	1-100-597-91	CERAMIC CHIP 0.1uF 10%	25V				
C753	1-100-597-91	CERAMIC CHIP 0.1uF 10%	25V	D706	6-501-743-01	DIODE MAZ8068GMLS0	
C755	1-100-597-91	CERAMIC CHIP 0.1uF 10%	25V			< IC >	
C756	1-100-597-91	CERAMIC CHIP 0.1uF 10%	25V	IC055	6-714-167-01	IC BD9702CP-V5	
C783	1-117-720-11	CERAMIC CHIP 4.7uF	10V	IC065	6-714-166-01	IC BD9701CP-V5	
C784	1-117-720-11	CERAMIC CHIP 4.7uF	10V	IC095	6-714-166-01	IC BD9701CP-V5	
C785	1-100-597-91	CERAMIC CHIP 0.1uF 10%	25V	IC200	6-713-032-01	IC KIA7809API-U/PF	
C786	1-100-597-91	CERAMIC CHIP 0.1uF 10%	25V	IC251	8-759-278-58	IC NJM4558V-TE2	
C787	1-100-597-91	CERAMIC CHIP 0.1uF 10%	25V	IC252	8-759-278-58	IC NJM4558V-TE2	
C789	1-100-597-91	CERAMIC CHIP 0.1uF 10%	25V	IC253	8-759-278-58	IC NJM4558V-TE2 (GTR7/GTR8/GTR8B)	
C790	1-100-385-91	CERAMIC CHIP 0.47uF	25V	IC254	8-759-278-58	IC NJM4558V-TE2 (GTR8/GTR8B)	
C796	1-100-597-91	CERAMIC CHIP 0.1uF 10%	25V	IC400	6-712-027-01	IC R2A15216FP	
C797	1-126-960-11	ELECT 1uF 20%	50V	IC450	8-759-278-58	IC NJM4558V-TE2 (GTR6B/GTR8B)	
			(GTR8/GTR8B)	IC451	8-759-278-58	IC NJM4558V-TE2 (GTR6B/GTR8B)	
			< CONNECTOR >	IC500	A-1733-993-A	IC R5F3640MDFAR	
CN010	1-568-826-11	CONNECTOR, FFC 7P (GTR6B/GTR8B)		IC675	6-713-627-01	IC BR24S16FJ-WE2	
* CN020	1-564-710-11	PIN, CONNECTOR (SMALL TYPE) 8P		IC676	6-701-760-01	IC uPC3504AHF	
			(GTR6B/GTR8B)	IC730	8-759-278-58	IC NJM4558V-TE2 (GTR7/GTR8/GTR8B)	
CN040	1-779-277-11	CONNECTOR, FFC (LIF (NON-ZIF)) 9P				< JACK >	
CN070	1-784-770-11	CONNECTOR, FFC 9P		J020	1-822-758-11	JACK, PIN 2P (VIDEO IN)	
* CN090	1-564-711-11	PIN, CONNECTOR (SMALL TYPE) 9P				< JUMPER RESISTOR >	
CN100	1-573-843-11	CONNECTOR, BOARD TO BOARD 11P		JR100	1-216-864-11	SHORT CHIP 0	
CN110	1-784-774-11	CONNECTOR, FFC 13P		JR101	1-216-864-11	SHORT CHIP 0	
CN150	1-784-784-11	CONNECTOR, FFC 23P		JR102	1-216-864-11	SHORT CHIP 0	
CN151	1-568-830-11	CONNECTOR, FFC 11P		JR103	1-216-296-11	SHORT CHIP 0	
CN200	1-770-827-21	CONNECTOR, BOARD TO BOARD 16P					
* CN310	1-564-506-11	PLUG, CONNECTOR 3P					
* CN320	1-564-506-11	PLUG, CONNECTOR 3P (GTR7/GTR8/GTR8B)					

# HCD-GTR6/GTR6B/GTR7/GTR8/GTR8B

Ver. 1.2

MAIN

Ref. No.	Part No.	Description	Remark
JR105	1-216-864-11	SHORT CHIP	0
JR106	1-216-296-11	SHORT CHIP	0
JR107	1-216-296-11	SHORT CHIP	0
JR109	1-216-864-11	SHORT CHIP	0
JR110	1-216-296-11	SHORT CHIP	0
JR111	1-216-864-11	SHORT CHIP	0
JR112	1-216-864-11	SHORT CHIP	0
JR113	1-216-864-11	SHORT CHIP	0
JR114	1-216-864-11	SHORT CHIP	0
JR115	1-216-864-11	SHORT CHIP	0
JR116	1-216-296-11	SHORT CHIP	0
JR117	1-216-296-11	SHORT CHIP	0
JR118	1-216-296-11	SHORT CHIP	0
JR119	1-216-864-11	SHORT CHIP	0
JR122	1-216-296-11	SHORT CHIP	0
JR123	1-216-296-11	SHORT CHIP	0
JR124	1-216-864-11	SHORT CHIP	0
JR125	1-216-864-11	SHORT CHIP	0
JR126	1-216-864-11	SHORT CHIP	0
JR129	1-216-864-11	SHORT CHIP	0
JR130	1-216-864-11	SHORT CHIP	0
JR131	1-216-864-11	SHORT CHIP	0
JR133	1-216-864-11	SHORT CHIP	0
JR192	1-216-864-11	SHORT CHIP	0
JR315	1-216-864-11	SHORT CHIP	0 (GTR6B/GTR8B)
JR316	1-216-864-11	SHORT CHIP	0 (GTR6B/GTR8B)
< COIL >			
L082	1-457-747-11	INDUCTOR	100uH
L091	1-457-752-11	INDUCTOR	47uH
L096	1-457-747-11	INDUCTOR	100uH
< TRANSISTOR >			
Q001	8-729-920-79	TRANSISTOR	2SB1132-T100-QR (GTR6B/GTR8B)
Q002	8-729-920-79	TRANSISTOR	2SB1132-T100-QR (GTR6B/GTR8B)
Q003	8-729-038-28	TRANSISTOR	RT1N441C-TP-1 (GTR6B/GTR8B)
Q004	8-729-038-28	TRANSISTOR	RT1N441C-TP-1 (GTR6B/GTR8B)
Q005	8-729-038-28	TRANSISTOR	RT1N441C-TP-1
Q006	8-729-620-07	TRANSISTOR	2SC3052EF-T1-LEF
Q007	8-729-037-13	TRANSISTOR	KTA1271Y
Q008	8-729-620-07	TRANSISTOR	2SC3052EF-T1-LEF
Q009	8-729-620-07	TRANSISTOR	2SC3052EF-T1-LEF
Q021	8-729-036-86	TRANSISTOR	KTC3203Y-AT
Q030	8-729-038-28	TRANSISTOR	RT1N441C-TP-1
Q031	8-729-620-07	TRANSISTOR	2SC3052EF-T1-LEF
Q032	8-729-620-07	TRANSISTOR	2SC3052EF-T1-LEF
Q033	8-729-040-76	TRANSISTOR	KTA1273-Y-AT
Q034	8-729-620-07	TRANSISTOR	2SC3052EF-T1-LEF
Q036	8-729-620-07	TRANSISTOR	2SC3052EF-T1-LEF (GTR7/GTR8/GTR8B)
Q037	8-729-620-07	TRANSISTOR	2SC3052EF-T1-LEF (GTR7/GTR8/GTR8B)
Q038	8-729-040-76	TRANSISTOR	KTA1273-Y-AT (GTR7/GTR8/GTR8B)
Q039	8-729-620-07	TRANSISTOR	2SC3052EF-T1-LEF (GTR7/GTR8/GTR8B)
Q113	6-551-696-01	TRANSISTOR	ISA1235AC1TP-1EF (GTR6B/GTR8B)

Ref. No.	Part No.	Description	Remark
Q128	8-729-620-07	TRANSISTOR	2SC3052EF-T1-LEF
Q178	8-729-620-07	TRANSISTOR	2SC3052EF-T1-LEF
Q210	8-729-620-07	TRANSISTOR	2SC3052EF-T1-LEF
Q245	8-729-620-07	TRANSISTOR	2SC3052EF-T1-LEF (GTR7/GTR8/GTR8B)
Q250	8-729-620-07	TRANSISTOR	2SC3052EF-T1-LEF
Q270	8-729-620-07	TRANSISTOR	2SC3052EF-T1-LEF
Q290	8-729-027-23	TRANSISTOR	DTA114EKA-T146
Q295	8-729-620-07	TRANSISTOR	2SC3052EF-T1-LEF (GTR8/GTR8B)
Q300	8-729-036-86	TRANSISTOR	KTC3203Y-AT (GTR6B/GTR8B)
Q301	8-729-037-13	TRANSISTOR	KTA1271Y (GTR6B/GTR8B)
Q302	8-729-620-07	TRANSISTOR	2SC3052EF-T1-LEF (GTR6B/GTR8B)
Q401	8-729-620-07	TRANSISTOR	2SC3052EF-T1-LEF (GTR6B/GTR8B)
Q402	8-729-620-07	TRANSISTOR	2SC3052EF-T1-LEF (GTR6B/GTR8B)
Q403	8-729-620-07	TRANSISTOR	2SC3052EF-T1-LEF (GTR6B/GTR8B)
Q404	8-729-620-07	TRANSISTOR	2SC3052EF-T1-LEF (GTR6B/GTR8B)
Q405	6-551-696-01	TRANSISTOR	ISA1235AC1TP-1EF (GTR6B/GTR8B)
Q406	6-551-696-01	TRANSISTOR	ISA1235AC1TP-1EF (GTR6B/GTR8B)
Q407	6-551-696-01	TRANSISTOR	ISA1235AC1TP-1EF (GTR6B/GTR8B)
Q408	8-729-620-07	TRANSISTOR	2SC3052EF-T1-LEF (GTR6B/GTR8B)
Q409	8-729-027-43	TRANSISTOR	DTC114EKA-T146 (GTR6B/GTR8B)
Q410	6-551-276-01	TRANSISTOR	RT1N431C-TP-1 (GTR6B/GTR8B)
Q456	6-551-696-01	TRANSISTOR	ISA1235AC1TP-1EF (GTR6B/GTR8B)
Q500	6-551-276-01	TRANSISTOR	RT1N431C-TP-1
Q501	8-729-027-26	TRANSISTOR	DTA114YKA-T146
Q532	6-551-681-01	TRANSISTOR	RT1P431C-TP-1
Q601	8-729-620-07	TRANSISTOR	2SC3052EF-T1-LEF
Q696	8-729-032-94	TRANSISTOR	2SD1859TV2Q
Q700	8-729-032-94	TRANSISTOR	2SD1859TV2Q
Q710	8-729-620-07	TRANSISTOR	2SC3052EF-T1-LEF
Q711	8-729-620-07	TRANSISTOR	2SC3052EF-T1-LEF
Q712	6-551-451-01	TRANSISTOR	2SB1690TL
Q713	8-729-038-28	TRANSISTOR	RT1N441C-TP-1
Q714	6-551-451-01	TRANSISTOR	2SB1690TL
Q717	8-729-038-28	TRANSISTOR	RT1N441C-TP-1
Q718	8-729-038-28	TRANSISTOR	RT1N441C-TP-1
Q719	8-729-038-28	TRANSISTOR	RT1N441C-TP-1
Q720	8-729-038-28	TRANSISTOR	RT1N441C-TP-1
Q788	8-729-924-99	TRANSISTOR	2SC3722K-E (GTR7/GTR8/GTR8B)
Q789	8-729-620-07	TRANSISTOR	2SC3052EF-T1-LEF (GTR7/GTR8/GTR8B)
< RESISTOR >			
R001	1-216-837-11	METAL CHIP	22K 5% 1/10W (GTR6B/GTR8B)
R002	1-216-833-11	METAL CHIP	10K 5% 1/10W (GTR6B/GTR8B)
R003	1-216-829-11	METAL CHIP	4.7K 5% 1/10W (GTR6B/GTR8B)

Ref. No.	Part No.	Description	Remark	Ref. No.	Part No.	Description	Remark
R004	1-216-827-11	METAL CHIP	3.3K 5% 1/10W (GTR6B/GTR8B)	R091	1-216-821-11	METAL CHIP	1K 5% 1/10W
R005	1-216-829-11	METAL CHIP	4.7K 5% 1/10W (GTR6B/GTR8B)	R094	1-216-834-11	METAL CHIP	12K 5% 1/10W
R006	1-216-827-11	METAL CHIP	3.3K 5% 1/10W (GTR6B/GTR8B)	R095	1-216-822-11	METAL CHIP	1.2K 5% 1/10W
R007	1-216-825-11	METAL CHIP	2.2K 5% 1/10W (GTR6B/GTR8B)	R096	1-216-825-11	METAL CHIP	2.2K 5% 1/10W
R008	1-216-827-11	METAL CHIP	3.3K 5% 1/10W (GTR6B/GTR8B)	R097	1-216-819-11	METAL CHIP	680 5% 1/10W
R009	1-216-833-11	METAL CHIP	10K 5% 1/10W (GTR6B/GTR8B)	R103	1-216-821-11	METAL CHIP	1K 5% 1/10W
R010	1-216-825-11	METAL CHIP	2.2K 5% 1/10W (GTR6B/GTR8B)	R104	1-216-849-11	METAL CHIP	220K 5% 1/10W
R011	1-216-827-11	METAL CHIP	3.3K 5% 1/10W (GTR6B/GTR8B)	R117	1-216-835-11	METAL CHIP	15K 5% 1/10W
R012	1-216-833-11	METAL CHIP	10K 5% 1/10W (GTR6B/GTR8B)	R121	1-216-833-11	METAL CHIP	10K 5% 1/10W
R013	1-216-864-11	SHORT CHIP	0	R122	1-216-833-11	METAL CHIP	10K 5% 1/10W
R014	1-216-833-11	METAL CHIP	10K 5% 1/10W	R127	1-216-819-11	METAL CHIP	680 5% 1/10W (GTR6/GTR6B)
R015	1-216-833-11	METAL CHIP	10K 5% 1/10W	R127	1-220-373-11	METAL CHIP	620 5% 1/10W (GTR7/GTR8/GTR8B)
R016	1-216-845-11	METAL CHIP	100K 5% 1/10W	R128	1-216-835-11	METAL CHIP	15K 5% 1/10W
R017	1-216-833-11	METAL CHIP	10K 5% 1/10W	R132	1-216-829-11	METAL CHIP	4.7K 5% 1/10W
R018	1-216-845-11	METAL CHIP	100K 5% 1/10W	R133	1-216-829-11	METAL CHIP	4.7K 5% 1/10W
R019	1-216-825-11	METAL CHIP	2.2K 5% 1/10W	R134	1-216-821-11	METAL CHIP	1K 5% 1/10W
R020	1-216-819-11	METAL CHIP	680 5% 1/10W	R135	1-216-841-11	METAL CHIP	47K 5% 1/10W
R022	1-216-823-11	METAL CHIP	1.5K 5% 1/10W	R137	1-216-864-11	SHORT CHIP	0
R023	1-249-397-11	CARBON	22 5% 1/4W	R138	1-216-833-11	METAL CHIP	10K 5% 1/10W
R024	1-249-397-11	CARBON	22 5% 1/4W	R141	1-216-864-11	SHORT CHIP	0
R025	1-249-397-11	CARBON	22 5% 1/4W	R144	1-216-821-11	METAL CHIP	1K 5% 1/10W
R026	1-218-867-11	METAL CHIP	6.8K 0.5% 1/10W (EXCEPT E2)	R145	1-216-839-11	METAL CHIP	33K 5% 1/10W
R026	1-216-834-11	METAL CHIP	12K 5% 1/10W (E2)	R153	1-216-821-11	METAL CHIP	1K 5% 1/10W
R027	1-216-833-11	METAL CHIP	10K 5% 1/10W	R154	1-216-849-11	METAL CHIP	220K 5% 1/10W
R028	1-218-867-11	METAL CHIP	6.8K 0.5% 1/10W (EXCEPT E2)	R177	1-216-819-11	METAL CHIP	680 5% 1/10W (GTR6/GTR6B)
R028	1-216-834-11	METAL CHIP	12K 5% 1/10W (E2)	R177	1-220-373-11	METAL CHIP	620 5% 1/10W (GTR7/GTR8/GTR8B)
R029	1-216-833-11	METAL CHIP	10K 5% 1/10W	R178	1-216-835-11	METAL CHIP	15K 5% 1/10W
R030	1-249-401-11	CARBON	47 5% 1/4W	R182	1-216-829-11	METAL CHIP	4.7K 5% 1/10W
R032	1-216-821-11	METAL CHIP	1K 5% 1/10W	R183	1-216-829-11	METAL CHIP	4.7K 5% 1/10W
R033	1-249-401-11	CARBON	47 5% 1/4W	R184	1-216-821-11	METAL CHIP	1K 5% 1/10W
R034	1-249-401-11	CARBON	47 5% 1/4W	R185	1-216-841-11	METAL CHIP	47K 5% 1/10W
R035	1-249-401-11	CARBON	47 5% 1/4W (GTR7/GTR8/GTR8B)	R187	1-216-864-11	SHORT CHIP	0
R036	1-249-401-11	CARBON	47 5% 1/4W (GTR7/GTR8/GTR8B)	R188	1-216-833-11	METAL CHIP	10K 5% 1/10W
R037	1-249-401-11	CARBON	47 5% 1/4W (GTR7/GTR8/GTR8B)	R190	1-216-857-11	METAL CHIP	1M 5% 1/10W
R039	1-216-845-11	METAL CHIP	100K 5% 1/10W	R191	1-216-864-11	SHORT CHIP	0
R040	1-216-833-11	METAL CHIP	10K 5% 1/10W	R192	1-216-845-11	METAL CHIP	100K 5% 1/10W
R044	1-216-864-11	SHORT CHIP	0	R194	1-216-821-11	METAL CHIP	1K 5% 1/10W
R047	1-216-821-11	METAL CHIP	1K 5% 1/10W (GTR7/GTR8/GTR8B)	R195	1-216-839-11	METAL CHIP	33K 5% 1/10W
R048	1-216-845-11	METAL CHIP	100K 5% 1/10W (GTR7/GTR8/GTR8B)	R196	1-216-833-11	METAL CHIP	10K 5% 1/10W
R049	1-216-833-11	METAL CHIP	10K 5% 1/10W (GTR7/GTR8/GTR8B)	R202	1-216-864-11	SHORT CHIP	0
R082	1-218-851-11	METAL CHIP	1.5K 5% 1/10W	R203	1-216-817-11	METAL CHIP	470 5% 1/10W
R083	1-218-865-11	METAL CHIP	5.6K 5% 1/10W	R204	1-216-845-11	METAL CHIP	100K 5% 1/10W
R086	1-218-844-11	METAL CHIP	750 5% 1/10W	R206	1-216-833-11	METAL CHIP	10K 5% 1/10W
R090	1-216-817-11	METAL CHIP	470 5% 1/10W	R208	1-216-838-11	METAL CHIP	27K 5% 1/10W
				R210	1-216-821-11	METAL CHIP	1K 5% 1/10W
				R211	1-216-844-11	METAL CHIP	82K 5% 1/10W
				R215	1-216-851-11	METAL CHIP	330K 5% 1/10W
				R216	1-216-809-11	METAL CHIP	100 5% 1/10W
				R217	1-218-272-11	METAL CHIP	5.1K 5% 1/10W
				R220	1-216-832-11	METAL CHIP	8.2K 5% 1/10W
				R221	1-216-817-11	METAL CHIP	470 5% 1/10W
				R222	1-216-837-11	METAL CHIP	22K 5% 1/10W
				R227	1-216-843-11	METAL CHIP	68K 5% 1/10W
				R228	1-216-821-11	METAL CHIP	1K 5% 1/10W
				R229	1-216-825-11	METAL CHIP	2.2K 5% 1/10W
				R231	1-216-838-11	METAL CHIP	27K 5% 1/10W (GTR7/GTR8/GTR8B)

# HCD-GTR6/GTR6B/GTR7/GTR8/GTR8B

Ver. 1.2

**MAIN**

Ref. No.	Part No.	Description	Remark	Ref. No.	Part No.	Description	Remark
R232	1-216-864-11	SHORT CHIP	0 (GTR7/GTR8/GTR8B)	R303	1-216-841-11	METAL CHIP	47K 5% 1/10W (GTR6B/GTR8B)
R233	1-216-845-11	METAL CHIP	100K 5% 1/10W (GTR7/GTR8/GTR8B)	R304	1-216-841-11	METAL CHIP	47K 5% 1/10W (GTR6B/GTR8B)
R235	1-218-867-11	METAL CHIP	6.8K 0.5% 1/10W (GTR8/GTR8B)	R305	1-216-864-11	SHORT CHIP	0 (GTR6B/GTR8B)
R236	1-218-867-11	METAL CHIP	6.8K 0.5% 1/10W (GTR8/GTR8B)	R306	1-216-864-11	SHORT CHIP	0 (GTR6B/GTR8B)
R240	1-216-832-11	METAL CHIP	8.2K 5% 1/10W (GTR8/GTR8B)	R307	1-216-829-11	METAL CHIP	4.7K 5% 1/10W (GTR6B/GTR8B)
R241	1-216-833-11	METAL CHIP	10K 5% 1/10W (GTR8/GTR8B)	R308	1-216-829-11	METAL CHIP	4.7K 5% 1/10W (GTR6B/GTR8B)
R242	1-216-821-11	METAL CHIP	1K 5% 1/10W (GTR7/GTR8/GTR8B)	R309	1-216-817-11	METAL CHIP	470 5% 1/10W (GTR6B/GTR8B)
R243	1-216-841-11	METAL CHIP	47K 5% 1/10W (GTR7/GTR8/GTR8B)	R310	1-216-817-11	METAL CHIP	470 5% 1/10W (GTR6B/GTR8B)
R244	1-216-825-11	METAL CHIP	2.2K 5% 1/10W (GTR7/GTR8/GTR8B)	R311	1-216-813-11	METAL CHIP	220 5% 1/10W (GTR6B/GTR8B)
R246	1-218-867-11	METAL CHIP	6.8K 0.5% 1/10W (GTR7)	R312	1-216-813-11	METAL CHIP	220 5% 1/10W (GTR6B/GTR8B)
R247	1-218-867-11	METAL CHIP	6.8K 0.5% 1/10W (GTR7)	R313	1-216-805-11	METAL CHIP	47 5% 1/10W (GTR6B/GTR8B)
R253	1-216-817-11	METAL CHIP	470 5% 1/10W	R314	1-216-805-11	METAL CHIP	47 5% 1/10W (GTR6B/GTR8B)
R256	1-216-833-11	METAL CHIP	10K 5% 1/10W	R315	1-216-809-11	METAL CHIP	100 5% 1/10W (GTR6B/GTR8B)
R258	1-216-838-11	METAL CHIP	27K 5% 1/10W	R316	1-216-809-11	METAL CHIP	100 5% 1/10W (GTR6B/GTR8B)
R270	1-216-832-11	METAL CHIP	8.2K 5% 1/10W	R317	1-216-853-11	METAL CHIP	470K 5% 1/10W (GTR6B/GTR8B)
R271	1-216-817-11	METAL CHIP	470 5% 1/10W	R318	1-216-853-11	METAL CHIP	470K 5% 1/10W (GTR6B/GTR8B)
R272	1-216-837-11	METAL CHIP	22K 5% 1/10W	R319	1-218-867-11	METAL CHIP	6.8K 0.5% 1/10W (GTR6B/GTR8B)
R275	1-216-803-11	METAL CHIP	33 5% 1/10W	R320	1-218-867-11	METAL CHIP	6.8K 0.5% 1/10W (GTR6B/GTR8B)
R276	1-216-841-11	METAL CHIP	47K 5% 1/10W	R321	1-216-801-11	METAL CHIP	22 5% 1/10W (GTR6B/GTR8B)
R277	1-216-843-11	METAL CHIP	68K 5% 1/10W	R322	1-216-837-11	METAL CHIP	22K 5% 1/10W (GTR6B/GTR8B)
R278	1-216-821-11	METAL CHIP	1K 5% 1/10W	R323	1-216-833-11	METAL CHIP	10K 5% 1/10W (GTR6B/GTR8B)
R279	1-216-825-11	METAL CHIP	2.2K 5% 1/10W	R324	1-216-833-11	METAL CHIP	10K 5% 1/10W (GTR6B/GTR8B)
R281	1-216-838-11	METAL CHIP	27K 5% 1/10W (GTR8/GTR8B)	R325	1-216-809-11	METAL CHIP	100 5% 1/10W (GTR6B/GTR8B)
R282	1-216-832-11	METAL CHIP	8.2K 5% 1/10W (GTR7)	R326	1-216-809-11	METAL CHIP	100 5% 1/10W (GTR6B/GTR8B)
R282	1-216-864-11	SHORT CHIP	0 (GTR8/GTR8B)	R329	1-216-801-11	METAL CHIP	22 5% 1/10W (GTR6B/GTR8B)
R283	1-216-845-11	METAL CHIP	100K 5% 1/10W (GTR8/GTR8B)	R330	1-216-801-11	METAL CHIP	22 5% 1/10W (GTR6B/GTR8B)
R284	1-216-833-11	METAL CHIP	10K 5% 1/10W (GTR7)	R331	1-216-793-11	METAL CHIP	4.7 5% 1/10W (GTR6B/GTR8B)
R285	1-218-867-11	METAL CHIP	6.8K 0.5% 1/10W (GTR8/GTR8B)	R332	1-216-829-11	METAL CHIP	4.7K 5% 1/10W (GTR6B/GTR8B)
R286	1-218-867-11	METAL CHIP	6.8K 0.5% 1/10W (GTR8/GTR8B)	R334	1-216-829-11	METAL CHIP	4.7K 5% 1/10W (GTR6B/GTR8B)
R290	1-216-832-11	METAL CHIP	8.2K 5% 1/10W (GTR8/GTR8B)	R335	1-216-841-11	METAL CHIP	47K 5% 1/10W (GTR6B/GTR8B)
R291	1-216-833-11	METAL CHIP	10K 5% 1/10W (GTR8/GTR8B)	R336	1-216-797-11	METAL CHIP	10 5% 1/10W (GTR6B/GTR8B)
R292	1-216-821-11	METAL CHIP	1K 5% 1/10W (GTR8/GTR8B)	R337	1-216-833-11	METAL CHIP	10K 5% 1/10W (GTR6B/GTR8B)
R293	1-216-821-11	METAL CHIP	1K 5% 1/10W (GTR7/GTR8/GTR8B)	R349	1-216-809-11	METAL CHIP	100 5% 1/10W (GTR6B/GTR8B)
R294	1-216-825-11	METAL CHIP	2.2K 5% 1/10W (GTR8/GTR8B)	R350	1-216-864-11	SHORT CHIP	0 (GTR6B/GTR8B)
R295	1-216-853-11	METAL CHIP	470K 5% 1/10W				
R296	1-216-825-11	METAL CHIP	2.2K 5% 1/10W				
R299	1-216-821-11	METAL CHIP	1K 5% 1/10W (GTR7/GTR8/GTR8B)				
R300	1-216-833-11	METAL CHIP	10K 5% 1/10W (GTR6B/GTR8B)				
R301	1-216-833-11	METAL CHIP	10K 5% 1/10W (GTR6B/GTR8B)				
R302	1-216-864-11	SHORT CHIP	0 (GTR6B/GTR8B)				

Ref. No.	Part No.	Description	Remark	Ref. No.	Part No.	Description	Remark
R351	1-216-821-11	METAL CHIP	1K 5% 1/10W (GTR6B/GTR8B)	R443	1-216-845-11	METAL CHIP	100K 5% 1/10W (GTR6B/GTR8B)
R359	1-216-841-11	METAL CHIP	47K 5% 1/10W (GTR8/GTR8B)	R444	1-216-833-11	METAL CHIP	10K 5% 1/10W (GTR6B/GTR8B)
R400	1-216-845-11	METAL CHIP	100K 5% 1/10W (GTR6B/GTR8B)	R481	1-216-833-11	METAL CHIP	10K 5% 1/10W (GTR6B/GTR8B)
R401	1-216-841-11	METAL CHIP	47K 5% 1/10W (GTR6B/GTR8B)	R482	1-216-841-11	METAL CHIP	47K 5% 1/10W (GTR6B/GTR8B)
R402	1-216-841-11	METAL CHIP	47K 5% 1/10W (GTR6B/GTR8B)	R484	1-216-825-11	METAL CHIP	2.2K 5% 1/10W (GTR6B/GTR8B)
R403	1-216-841-11	METAL CHIP	47K 5% 1/10W (GTR6B/GTR8B)	R501	1-216-809-11	METAL CHIP	100 5% 1/10W
R404	1-216-841-11	METAL CHIP	47K 5% 1/10W (GTR6B/GTR8B)	R502	1-216-809-11	METAL CHIP	100 5% 1/10W
R405	1-216-841-11	METAL CHIP	47K 5% 1/10W (GTR6B/GTR8B)	R503	1-216-809-11	METAL CHIP	100 5% 1/10W
				R504	1-216-809-11	METAL CHIP	100 5% 1/10W
				R507	1-216-809-11	METAL CHIP	100 5% 1/10W
R406	1-216-841-11	METAL CHIP	47K 5% 1/10W (GTR6B/GTR8B)	R509	1-216-833-11	METAL CHIP	10K 5% 1/10W
R407	1-218-867-11	METAL CHIP	6.8K 0.5% 1/10W (GTR6B/GTR8B)	R510	1-219-570-11	METAL CHIP	10M 5% 1/10W
R408	1-218-867-11	METAL CHIP	6.8K 0.5% 1/10W (GTR6B/GTR8B)	R511	1-216-849-11	METAL CHIP	220K 5% 1/10W
R409	1-216-845-11	METAL CHIP	100K 5% 1/10W (GTR6B/GTR8B)	R517	1-216-864-11	SHORT CHIP	0
R411	1-216-854-11	METAL CHIP	560K 5% 1/10W (GTR6B/GTR8B)	R518	1-216-809-11	METAL CHIP	100 5% 1/10W
R412	1-216-854-11	METAL CHIP	560K 5% 1/10W (GTR6B/GTR8B)	R519	1-216-809-11	METAL CHIP	100 5% 1/10W
R413	1-216-853-11	METAL CHIP	470K 5% 1/10W (GTR6B/GTR8B)	R521	1-216-809-11	METAL CHIP	100 5% 1/10W
R414	1-216-853-11	METAL CHIP	470K 5% 1/10W (GTR6B/GTR8B)	R523	1-216-809-11	METAL CHIP	100 5% 1/10W
R423	1-216-845-11	METAL CHIP	100K 5% 1/10W (GTR6B/GTR8B)	R524	1-216-809-11	METAL CHIP	100 5% 1/10W
R424	1-216-845-11	METAL CHIP	100K 5% 1/10W (GTR6B/GTR8B)	R525	1-216-809-11	METAL CHIP	100 5% 1/10W
R427	1-216-797-11	METAL CHIP	10 5% 1/10W (GTR6B/GTR8B)	R526	1-216-809-11	METAL CHIP	100 5% 1/10W
R428	1-216-797-11	METAL CHIP	10 5% 1/10W (GTR6B/GTR8B)	R528	1-216-809-11	METAL CHIP	100 5% 1/10W
R429	1-216-833-11	METAL CHIP	10K 5% 1/10W (GTR6B/GTR8B)	R529	1-216-833-11	METAL CHIP	10K 5% 1/10W
R430	1-216-833-11	METAL CHIP	10K 5% 1/10W (GTR6B/GTR8B)	R530	1-216-833-11	METAL CHIP	10K 5% 1/10W
R431	1-216-821-11	METAL CHIP	1K 5% 1/10W (GTR6B/GTR8B)	R532	1-216-864-11	SHORT CHIP	0
R432	1-216-821-11	METAL CHIP	1K 5% 1/10W (GTR6B/GTR8B)	R533	1-216-809-11	METAL CHIP	100 5% 1/10W
R433	1-216-841-11	METAL CHIP	47K 5% 1/10W (GTR6B/GTR8B)	R534	1-216-809-11	METAL CHIP	100 5% 1/10W
R434	1-216-841-11	METAL CHIP	47K 5% 1/10W (GTR6B/GTR8B)	R535	1-216-809-11	METAL CHIP	100 5% 1/10W
R435	1-216-833-11	METAL CHIP	10K 5% 1/10W (GTR6B/GTR8B)	R536	1-216-809-11	METAL CHIP	100 5% 1/10W
R436	1-216-833-11	METAL CHIP	10K 5% 1/10W (GTR6B/GTR8B)	R537	1-216-813-11	METAL CHIP	220 5% 1/10W
R437	1-216-825-11	METAL CHIP	2.2K 5% 1/10W (GTR6B/GTR8B)	R538	1-216-809-11	METAL CHIP	100 5% 1/10W
R438	1-216-825-11	METAL CHIP	2.2K 5% 1/10W (GTR6B/GTR8B)	R539	1-216-809-11	METAL CHIP	100 5% 1/10W
R439	1-216-864-11	SHORT CHIP	0 (GTR6B/GTR8B)	R540	1-216-809-11	METAL CHIP	100 5% 1/10W
R440	1-216-833-11	METAL CHIP	10K 5% 1/10W (GTR6B/GTR8B)	R542	1-216-809-11	METAL CHIP	100 5% 1/10W
R442	1-216-841-11	METAL CHIP	47K 5% 1/10W (GTR6B/GTR8B)	R543	1-216-809-11	METAL CHIP	100 5% 1/10W
				R544	1-216-809-11	METAL CHIP	100 5% 1/10W
				R545	1-216-809-11	METAL CHIP	100 5% 1/10W
				R546	1-216-833-11	METAL CHIP	10K 5% 1/10W
				R547	1-216-809-11	METAL CHIP	100 5% 1/10W
				R548	1-216-809-11	METAL CHIP	100 5% 1/10W
				R549	1-216-809-11	METAL CHIP	100 5% 1/10W
				R550	1-216-809-11	METAL CHIP	100 5% 1/10W
				R560	1-216-809-11	METAL CHIP	100 5% 1/10W
				R567	1-216-821-11	METAL CHIP	1K 5% 1/10W
				R569	1-216-837-11	METAL CHIP	22K 5% 1/10W
				R573	1-216-809-11	METAL CHIP	100 5% 1/10W
				R587	1-216-821-11	METAL CHIP	1K 5% 1/10W
				R588	1-216-835-11	METAL CHIP	15K 5% 1/10W
				R591	1-216-819-11	METAL CHIP	680 5% 1/10W (GTR8B)
				R591	1-216-823-11	METAL CHIP	1.5K 5% 1/10W (GTR6B)
				R591	1-216-829-11	METAL CHIP	4.7K 5% 1/10W (GTR6/GTR7/GTR8)
				R592	1-216-819-11	METAL CHIP	680 5% 1/10W (MX)

# HCD-GTR6/GTR6B/GTR7/GTR8/GTR8B

Ver. 1.2

**MAIN** **MIC CD**

Ref. No.	Part No.	Description	Remark
R592	1-216-821-11	METAL CHIP 1K	5% 1/10W (E2, E51, AR)
R592	1-216-829-11	METAL CHIP 4.7K	5% 1/10W (GTR6B/GTR8B)
R597	1-216-833-11	METAL CHIP 10K	5% 1/10W
R605	1-216-845-11	METAL CHIP 100K	5% 1/10W
R606	1-216-837-11	METAL CHIP 22K	5% 1/10W
R607	1-216-837-11	METAL CHIP 22K	5% 1/10W
R608	1-216-826-11	METAL CHIP 2.7K	5% 1/10W (GTR7)
R608	1-216-827-11	METAL CHIP 3.3K	5% 1/10W (GTR6/GTR6B/GTR8/GTR8B)
R609	1-216-864-11	SHORT CHIP 0	
R612	1-215-891-11	METAL OXIDE 680	5% 2W (GTR6/GTR6B)
R612	1-215-892-11	METAL OXIDE 1K	5% 2W (GTR7/GTR8/GTR8B)
R613	1-215-891-11	METAL OXIDE 680	5% 2W (GTR6/GTR6B)
R613	1-215-892-11	METAL OXIDE 1K	5% 2W (GTR7/GTR8/GTR8B)
R615	1-216-815-11	METAL CHIP 330	5% 1/10W
R616	1-216-815-11	METAL CHIP 330	5% 1/10W
R617	1-216-815-11	METAL CHIP 330	5% 1/10W
R618	1-216-815-11	METAL CHIP 330	5% 1/10W
R619	1-216-815-11	METAL CHIP 330	5% 1/10W
R620	1-216-815-11	METAL CHIP 330	5% 1/10W
R632	1-216-833-11	METAL CHIP 10K	5% 1/10W
R658	1-216-833-11	METAL CHIP 10K	5% 1/10W
R661	1-216-833-11	METAL CHIP 10K	5% 1/10W
R663	1-216-833-11	METAL CHIP 10K	5% 1/10W
R665	1-216-833-11	METAL CHIP 10K	5% 1/10W
R666	1-216-823-11	METAL CHIP 1.5K	5% 1/10W
R669	1-216-845-11	METAL CHIP 100K	5% 1/10W
R676	1-216-833-11	METAL CHIP 10K	5% 1/10W
R677	1-216-833-11	METAL CHIP 10K	5% 1/10W
R687	1-216-833-11	METAL CHIP 10K	5% 1/10W
R688	1-216-835-11	METAL CHIP 15K	5% 1/10W
R690	1-216-835-11	METAL CHIP 15K	5% 1/10W
R691	1-216-815-11	METAL CHIP 330	5% 1/10W (GTR6)
R691	1-216-819-11	METAL CHIP 680	5% 1/10W (GTR7)
R691	1-216-821-11	METAL CHIP 1K	5% 1/10W (GTR8)
R691	1-216-829-11	METAL CHIP 4.7K	5% 1/10W (GTR6B/GTR8B)
R692	1-216-815-11	METAL CHIP 330	5% 1/10W (E3)
R692	1-216-823-11	METAL CHIP 1.5K	5% 1/10W (AUS)
R692	1-216-829-11	METAL CHIP 4.7K	5% 1/10W (GTR6/GTR7/GTR8)
R693	1-216-833-11	METAL CHIP 10K	5% 1/10W
R694	1-216-833-11	METAL CHIP 10K	5% 1/10W
R698	1-216-837-11	METAL CHIP 22K	5% 1/10W
R700	1-216-823-11	METAL CHIP 1.5K	5% 1/10W
R702	1-216-833-11	METAL CHIP 10K	5% 1/10W
R706	1-216-829-11	METAL CHIP 4.7K	5% 1/10W
R707	1-216-827-11	METAL CHIP 3.3K	5% 1/10W
R710	1-216-821-11	METAL CHIP 1K	5% 1/10W
R711	1-216-821-11	METAL CHIP 1K	5% 1/10W
R712	1-216-821-11	METAL CHIP 1K	5% 1/10W

Ref. No.	Part No.	Description	Remark
R713	1-216-833-11	METAL CHIP 10K	5% 1/10W
R714	1-216-833-11	METAL CHIP 10K	5% 1/10W
R715	1-216-811-11	METAL CHIP 150	5% 1/10W
R717	1-216-845-11	METAL CHIP 100K	5% 1/10W
R718	1-216-833-11	METAL CHIP 10K	5% 1/10W
R738	1-216-841-11	METAL CHIP 47K	5% 1/10W (GTR7/GTR8/GTR8B)
R748	1-216-830-11	METAL CHIP 5.6K	5% 1/10W (GTR7/GTR8/GTR8B)
R749	1-218-331-11	METAL CHIP 51K	5% 1/10W (GTR7/GTR8/GTR8B)
R786	1-216-857-11	METAL CHIP 1M	5% 1/10W
R787	1-216-857-11	METAL CHIP 1M	5% 1/10W
R788	1-216-841-11	METAL CHIP 47K	5% 1/10W (GTR8/GTR8B)
R789	1-216-821-11	METAL CHIP 1K	5% 1/10W (GTR7/GTR8/GTR8B)
R793	1-216-829-11	METAL CHIP 4.7K	5% 1/10W
R794	1-216-829-11	METAL CHIP 4.7K	5% 1/10W
R795	1-216-821-11	METAL CHIP 1K	5% 1/10W
R797	1-216-821-11	METAL CHIP 1K	5% 1/10W (GTR7/GTR8/GTR8B)
R798	1-216-830-11	METAL CHIP 5.6K	5% 1/10W (GTR8/GTR8B)
R799	1-218-331-11	METAL CHIP 51K	5% 1/10W (GTR8/GTR8B)
< TRANSFORMER >			
T300	1-443-760-11	TRANSFORMER, BIAS OSCILLATION	(GTR6B/GTR8B)
< VIBRATOR >			
X510	1-814-067-11	OSCILLATOR, CRYSTAL (32.768KHZ)	
X514	1-795-058-21	VIBRATOR, CERAMIC (5MHZ)	
*****			
MIC CD BOARD			
*****			
< CAPACITOR >			
C1004	1-164-156-11	CERAMIC CHIP 0.1uF	25V
C1010	1-115-416-11	CERAMIC CHIP 0.001uF	5% 25V
C1012	1-126-791-11	ELECT 10uF	20% 16V
C1014	1-115-872-11	ELECT 2.2uF	20% 50V
C1015	1-162-964-11	CERAMIC CHIP 0.001uF	10% 50V
C1017	1-162-962-11	CERAMIC CHIP 470PF	10% 50V
C1018	1-162-960-11	CERAMIC CHIP 220PF	10% 50V
C1019	1-115-870-11	ELECT 0.47uF	20% 50V
C1020	1-162-959-11	CERAMIC CHIP 330PF	5% 50V
C1021	1-115-872-11	ELECT 2.2uF	20% 50V
C1022	1-164-156-11	CERAMIC CHIP 0.1uF	25V
C1023	1-126-791-11	ELECT 10uF	20% 16V
C1026	1-115-872-11	ELECT 2.2uF	20% 50V
C1027	1-112-514-91	CERAMIC CHIP 1500PF	5% 50V
C1028	1-115-871-11	ELECT 1.0uF	20% 50V
C1029	1-164-156-11	CERAMIC CHIP 0.1uF	25V
< DIODE >			
D1002	6-500-848-01	DIODE MC2840-T112-1	
D1004	1-822-757-11	DIODE MC2840-T112-1	

MIC CD MIC RV MOTOR(TB) MOTOR(LD) SENSOR STR

Ref. No.	Part No.	Description	Remark	Ref. No.	Part No.	Description	Remark
		< IC >				STR BOARD *****	
IC1000	8-759-278-58	IC NJM4558V-TE2				< CAPACITOR >	
		< JACK >					
J1001	1-764-767-21	JACK, PIN 2P (AUDIO INPUT LR)		C920	1-162-927-11	CERAMIC CHIP 100PF 5% 50V	
J1004	1-817-629-11	JACK (LARGE TYPE) (MIC)		C921	1-162-927-11	CERAMIC CHIP 100PF 5% 50V	
		< JUMPER RESISTOR >		C922	1-162-927-11	CERAMIC CHIP 100PF 5% 50V	
JR1021	1-216-864-11	SHORT CHIP 0		C923	1-107-826-11	CERAMIC CHIP 0.1uF 10% 16V	
		< RESISTOR >		C925	1-162-964-11	CERAMIC CHIP 0.001uF 10% 50V	
R1000	1-216-838-11	METAL CHIP 27K 5% 1/10W					
R1001	1-216-838-11	METAL CHIP 27K 5% 1/10W		C926	1-162-964-11	CERAMIC CHIP 0.001uF 10% 50V	
R1003	1-216-849-11	METAL CHIP 220K 5% 1/10W				< CONNECTOR >	
R1004	1-216-849-11	METAL CHIP 220K 5% 1/10W		CN903C	1-785-332-11	PIN, CONNECTOR (LIGHT ANGLE) 6P	
R1009	1-216-845-11	METAL CHIP 100K 5% 1/10W				< DIODE >	
R1010	1-216-841-11	METAL CHIP 47K 5% 1/10W		D919	8-719-060-27	DIODE SLR-325MCT31 (GTR7/GTR8/GTR8B)	
R1011	1-216-841-11	METAL CHIP 47K 5% 1/10W		D920	6-502-469-01	DI SLI-325URT31	
R1012	1-216-833-11	METAL CHIP 10K 5% 1/10W		D921	6-502-469-01	DI SLI-325URT31	
R1013	1-216-821-11	METAL CHIP 1K 5% 1/10W		D922	6-502-469-01	DI SLI-325URT31	
R1019	1-216-827-11	METAL CHIP 3.3 5% 1/10W		D923	6-502-468-01	DI 1L034FV22D0DAC09	
R1020	1-218-296-11	METAL CHIP 75K 5% 1/10W		D924	6-502-468-01	DI 1L034FV22D0DAC09	
R1021	1-216-835-11	METAL CHIP 15K 5% 1/10W		D925	6-502-468-01	DI 1L034FV22D0DAC09	
R1022	1-216-809-11	METAL CHIP 100 5% 1/10W		D926	6-502-468-01	DI 1L034FV22D0DAC09	
R1023	1-216-845-11	METAL CHIP 100K 5% 1/10W		D927	6-502-468-01	DI 1L034FV22D0DAC09	
R1025	1-216-821-11	METAL CHIP 1K 5% 1/10W		D928	6-502-468-01	DI 1L034FV22D0DAC09	
R1026	1-216-809-11	METAL CHIP 100 5% 1/10W		D929	6-502-469-01	DI SLI-325URT31	
*****				D930	6-502-469-01	DI SLI-325URT31	
*****				D931	6-502-469-01	DI SLI-325URT31	
*****						< IC >	
		MIC RV BOARD		IC901	6-713-768-01	IC R8A66166SP	
		*****				< RESISTOR >	
		< VARIABLE RESISTOR >		R929	1-216-819-11	METAL CHIP 680 5% 1/10W	
RV1001	1-227-452-11	RES, VAR, CARBON (MIC LEVEL) 50K				(GTR7/GTR8/GTR8B)	
*****				R931	1-216-819-11	METAL CHIP 680 5% 1/10W	
		MOTOR (TB) BOARD		R933	1-216-819-11	METAL CHIP 680 5% 1/10W	
		*****		R935	1-216-819-11	METAL CHIP 680 5% 1/10W	
		< CONNECTOR >		R937	1-216-817-11	METAL CHIP 470 5% 1/10W	
CN742	1-784-727-11	CONNECTOR, FFC 5P		R938	1-216-817-11	METAL CHIP 470 5% 1/10W	
*****				R939	1-216-819-11	METAL CHIP 680 5% 1/10W	
		MOTOR (LD) BOARD		R940	1-216-819-11	METAL CHIP 680 5% 1/10W	
		*****		R941	1-216-821-11	METAL CHIP 1K 5% 1/10W	
*****				R942	1-216-821-11	METAL CHIP 1K 5% 1/10W	
		SENSOR BOARD		R943	1-216-823-11	METAL CHIP 1.5K 5% 1/10W	
		*****		R944	1-216-823-11	METAL CHIP 1.5K 5% 1/10W	
		< CONNECTOR >		R945	1-216-823-11	METAL CHIP 1.5K 5% 1/10W	
CN731	1-785-329-21	PIN, CONNECTOR (LIGHT ANGLE) 3P		R946	1-216-823-11	METAL CHIP 1.5K 5% 1/10W	
		< IC >		R947	1-216-825-11	METAL CHIP 2.2K 5% 1/10W	
IC731	6-600-564-01	IC RPI-579N1		R948	1-216-825-11	METAL CHIP 2.2K 5% 1/10W	
*****				R949	1-216-827-11	METAL CHIP 3.3K 5% 1/10W	
				R950	1-216-827-11	METAL CHIP 3.3K 5% 1/10W	
				R951	1-216-829-11	METAL CHIP 4.7K 5% 1/10W	
				R952	1-216-829-11	METAL CHIP 4.7K 5% 1/10W	
				R953	1-218-867-11	METAL CHIP 6.8K 0.5% 1/10W	
				R954	1-218-867-11	METAL CHIP 6.8K 0.5% 1/10W	
				R955	1-216-833-11	METAL CHIP 10K 5% 1/10W	
				R956	1-216-833-11	METAL CHIP 10K 5% 1/10W	
				R957	1-216-833-11	METAL CHIP 10K 5% 1/10W	

# HCD-GTR6/GTR6B/GTR7/GTR8/GTR8B

Ver. 1.2

**STR**   **SUBTRANS**   **SUBWOOFER**

Ref. No.	Part No.	Description	Remark
R958	1-216-819-11	METAL CHIP 680 5%	1/10W
R960	1-216-819-11	METAL CHIP 680 5%	1/10W
R962	1-216-819-11	METAL CHIP 680 5%	1/10W
R964	1-216-819-11	METAL CHIP 680 5%	1/10W
R965	1-216-835-11	METAL CHIP 15K 5%	1/10W
R966	1-216-835-11	METAL CHIP 15K 5%	1/10W
R968	1-216-837-11	METAL CHIP 22K 5%	1/10W
R969	1-216-839-11	METAL CHIP 33K 5%	1/10W
R970	1-216-843-11	METAL CHIP 68K 5%	1/10W
R971	1-216-833-11	METAL CHIP 10K 5%	1/10W
R973	1-216-819-11	METAL CHIP 680 5%	1/10W
R975	1-216-819-11	METAL CHIP 680 5%	1/10W
R977	1-216-819-11	METAL CHIP 680 5%	1/10W
R979	1-216-819-11	METAL CHIP 680 5%	1/10W
R981	1-216-819-11	METAL CHIP 680 5%	1/10W
R985	1-216-829-11	METAL CHIP 4.7K 5%	1/10W
R986	1-216-809-11	METAL CHIP 100 5%	1/10W
R987	1-216-809-11	METAL CHIP 100 5%	1/10W
R988	1-216-809-11	METAL CHIP 100 5%	1/10W
R989	1-216-833-11	METAL CHIP 10K 5%	1/10W
R990	1-216-864-11	SHORT CHIP 0	
< SWITCH >			
S933	1-771-410-21	SWITCH, TACTILE (SUBWOOFER ON/OFF) (GTR7/GTR8/GTR8B)	
S937	1-771-410-21	SWITCH, TACTILE (SUBWOOFER LEVEL) (GTR7/GTR8/GTR8B)	
S915	1-771-410-21	SWITCH, TACTILE (STOP)	
S916	1-771-410-21	SWITCH, TACTILE (EQ BAND/MEMORY)	
S917	1-771-410-21	SWITCH, TACTILE (TUNING-(CD))	
S918	1-771-410-21	SWITCH, TACTILE (SURR SP MODE(CD))	
S919	1-771-410-21	SWITCH, TACTILE (TUNING-(CD))	
S920	1-771-410-21	SWITCH, TACTILE (NIGHT MODE)	
S921	1-771-410-21	SWITCH, TACTILE (PLAY)	
S922	1-771-410-21	SWITCH, TACTILE (SOUND FLASH)	
S923	1-771-410-21	SWITCH, TACTILE (ALBUM-(CD))	
S924	1-771-410-21	SWITCH, TACTILE (BREAK)	
S925	1-771-410-21	SWITCH, TACTILE (RETURN)	
S926	1-771-410-21	SWITCH, TACTILE (MP3 BOOSTER + (CD))	
S927	1-771-410-21	SWITCH, TACTILE (CD)	
S928	1-771-410-21	SWITCH, TACTILE (GROOVE)	
S929	1-771-410-21	SWITCH, TACTILE (USB)	
S930	1-771-410-21	SWITCH, TACTILE (PRESET EQ)	
S931	1-771-410-21	SWITCH, TACTILE (PC(CD))	
S932	1-771-410-21	SWITCH, TACTILE (ALBUM + (CD))	
S934	1-771-410-21	SWITCH, TACTILE (PAUSE)	
S935	1-487-171-11	ROTARY ENCODER (MASTER_VOL)	
S936	1-480-581-11	ROTARY ENCODER (OP_DUAL)	
S938	1-771-410-21	SWITCH, TACTILE (ENTER)	
S940	1-771-410-21	SWITCH, TACTILE (TUNER/BAND)	
S941	1-771-410-21	SWITCH, TACTILE (TAPE)	
S942	1-771-410-21	SWITCH, TACTILE (VIDEO)	
S945	1-771-410-21	SWITCH, TACTILE (REC TO USB)	
*****			
SUBTRANS BOARD			
*****			
< CAPACITOR >			
C1200	1-164-156-11	CERAMIC CHIP 0.1uF	25V
C1201	1-164-156-11	CERAMIC CHIP 0.1uF	25V

Ref. No.	Part No.	Description	Remark
C1203	1-126-942-61	ELECT 1000uF 20%	25V
C1204	1-126-963-11	ELECT 4.7uF 20%	50V
C1205	1-164-156-11	CERAMIC CHIP 0.1uF	25V
C1206	1-164-156-11	CERAMIC CHIP 0.1uF	25V
< CONNECTOR >			
CN1201	1-568-106-11	PIN, CONNECTOR (3.96mm PITCH) 4P	(E2, E51, E3)
CN1202	1-564-321-00	PIN, CONNECTOR (3.96mm PITCH) 2P	(AR, AUS, MX)
CN1200	1-564-321-00	PIN, CONNECTOR (3.96mm PITCH) 2P	
CN1203	1-785-316-11	PIN, CONNECTOR (STRAIGHT) 4P	
< DIODE >			
D1200	6-501-817-01	DIODE MA2J1110GLS0	
D1201	6-500-848-01	DIODE MC2840-T112-1	
D1202	6-500-848-01	DIODE MC2840-T112-1	
D1203	6-500-335-01	DIODE MC2838-T112-1	
< TRANSFORMER >			
PT1200	1-443-927-11	TRANSFORMER, POWER (SUB) (MX)	
PT1200	1-443-927-21	TRANSFORMER, POWER (SUB) (MX)	
PT1200	1-443-928-11	TRANSFORMER, POWER (SUB) (EXCEPT MX)	
PT1200	1-443-928-21	TRANSFORMER, POWER (SUB) (EXCEPT MX)	
< TRANSISTOR >			
Q1200	8-729-620-07	TRANSISTOR 2SC3052EF-T1-LEF	
< RESISTOR >			
R1201	1-216-819-11	METAL CHIP 680 5%	1/10W
R1202	1-216-825-11	METAL CHIP 2.2K 5%	1/10W
R1205	1-216-845-11	METAL CHIP 100K 5%	1/10W
< RELAY >			
RY1200	1-755-334-11	RELAY, AC POWER	
< SWITCH >			
S1200	1-786-055-31	SELECTOR, VOLTAGE (VOLTAGE SELECTOR) (E2, E51, E3)	
*****			
SUBWOOFER BOARD			
(GTR7/GTR8/GTR8B)			
*****			
< CAPACITOR >			
C800	1-126-947-11	ELECT 47uF 20%	35V
C801	1-162-964-11	CERAMIC CHIP 0.001uF 10%	50V
C802	1-126-963-11	ELECT 4.7uF 20%	50V
C803	1-162-927-11	CERAMIC CHIP 100PF 5%	50V
C808	1-162-915-11	CERAMIC CHIP 10PF 0.5PF	50V (GTR7/GTR8/GTR8B)
C818	1-126-947-11	ELECT 47uF 20%	35V (GTR7/GTR8: E2, E51, AR/GTR8B)
C819	1-164-156-11	CERAMIC CHIP 0.1uF	25V (GTR7/GTR8: E2, E51, AR/GTR8B)
C820	1-164-156-11	CERAMIC CHIP 0.1uF	25V (GTR7/GTR8: E2, E51, AR/GTR8B)
C825	1-128-551-11	ELECT 22uF 20%	63V (GTR8/GTR8B)
C825	1-128-552-51	ELECT 47uF 20%	63V (GTR7)



Ref. No.	Part No.	Description	Remark	Ref. No.	Part No.	Description	Remark
C826	1-128-551-11	ELECT	22uF 20% 63V (GTR8/GTR8B)			< RESISTOR >	
C826	1-128-552-51	ELECT	47uF 20% 63V (GTR7)	R800	1-216-817-11	METAL CHIP	470 5% 1/10W (GTR8/GTR8B)
C846	1-115-339-11	CERAMIC CHIP	0.1uF 10% 50V	R800	1-216-819-11	METAL CHIP	680 5% 1/10W (GTR7)
C847	1-115-339-11	CERAMIC CHIP	0.1uF 10% 50V	R801	1-216-841-11	METAL CHIP	47K 5% 1/10W (GTR7)
C850	1-126-947-11	ELECT	47uF 20% 35V	R801	1-216-843-11	METAL CHIP	68K 5% 1/10W (GTR8/GTR8B)
C851	1-162-964-11	CERAMIC CHIP	0.001uF 10% 50V	R802	1-216-821-11	METAL CHIP	1K 5% 1/10W (GTR7/GTR8/GTR8B)
C852	1-126-963-11	ELECT	4.7uF 20% 50V	R808	1-216-841-11	METAL CHIP	47K 5% 1/10W (GTR7)
C853	1-162-927-11	CERAMIC CHIP	100PF 5% 50V	R808	1-216-843-11	METAL CHIP	68K 5% 1/10W (GTR8/GTR8B)
C858	1-162-915-11	CERAMIC CHIP	10PF 0.5PF 50V (GTR7/GTR8/GTR8B)	R815	1-249-401-11	CARBON	47 5% 1/4W (GTR7/GTR8: E2, E51, AR/GTR8B)
C875	1-128-557-11	ELECT	0.1uF 20% 100V (GTR7/GTR8/GTR8B)	R816	1-249-401-11	CARBON	47 5% 1/4W (GTR7/GTR8: E2, E51, AR/GTR8B)
C876	1-128-557-11	ELECT	0.1uF 20% 100V (GTR7/GTR8/GTR8B)	R817	1-249-401-11	CARBON	47 5% 1/4W (GTR7/GTR8: E2, E51, AR/GTR8B)
C892	1-126-963-11	ELECT	4.7uF 20% 50V (GTR7)	R818	1-216-845-11	METAL CHIP	100K 5% 1/10W (GTR7/GTR8: E2, E51, AR/GTR8B)
C896	1-115-339-11	CERAMIC CHIP	0.1uF 10% 50V	R819	1-216-833-11	METAL CHIP	10K 5% 1/10W (GTR7/GTR8: E2, E51, AR/GTR8B)
C897	1-115-339-11	CERAMIC CHIP	0.1uF 10% 50V	R822	1-216-821-11	METAL CHIP	1K 5% 1/10W (GTR7/GTR8: E2, E51, AR/GTR8B)
		< CONNECTOR >		R836	1-245-711-31	CARBON	10 5% 1/2W (GTR7)
CN801	1-766-724-11	CONNECTOR, BOARD TO BOARD 7P	(GTR7)	R839	1-216-825-11	METAL CHIP	2.2K 5% 1/10W (GTR8/GTR8B)
CN802	1-784-031-41	CONNECTOR, BOARD TO BOARD 8P	(GTR8/GTR8B)	R839	1-216-826-11	METAL CHIP	2.7K 5% 1/10W (GTR7)
* CN820	1-564-506-11	PLUG, CONNECTOR 3P	(GTR7/GTR8: E2, E51, AR/GTR8B)	R839	1-216-835-11	METAL CHIP	15K 5% 1/10W (GTR7)
* CN803	1-564-510-11	PLUG, CONNECTOR 7P		R840	1-216-825-11	METAL CHIP	2.2K 5% 1/10W (GTR7)
		< DIODE >		R840	1-216-835-11	METAL CHIP	15K 5% 1/10W (GTR8/GTR8B)
D817	6-501-772-01	DIODE MAZ8130GMLS0	(GTR7/GTR8: E2, E51, AR/GTR8B)	R840	1-216-837-11	METAL CHIP	22K 5% 1/10W (GTR7/GTR8)
D800	6-500-335-01	DIODE MC2838-T112-1		R841	1-216-848-11	METAL CHIP	180K 5% 1/10W (GTR8)
D811	6-501-817-01	DIODE MA2J1110GLS0		R841	1-216-850-11	METAL CHIP	270K 5% 1/10W (GTR7)
D812	6-501-817-01	DIODE MA2J1110GLS0		R850	1-216-817-11	METAL CHIP	470 5% 1/10W (GTR8/GTR8B)
		< IC >		R850	1-216-821-11	METAL CHIP	1K 5% 1/10W (GTR7)
IC800	6-600-562-01	IC STK433-100-E	(GTR7)	R851	1-216-841-11	METAL CHIP	47K 5% 1/10W (GTR7)
IC800	6-710-842-01	IC STK433-130-E	(GTR8/GTR8B)	R851	1-216-843-11	METAL CHIP	68K 5% 1/10W (GTR8/GTR8B)
		< JUMPER RESISTOR >		R852	1-216-821-11	METAL CHIP	1K 5% 1/10W (GTR7/GTR8/GTR8B)
JR804	1-216-296-11	SHORT CHIP	0	R858	1-216-841-11	METAL CHIP	47K 5% 1/10W (GTR7)
JR811	1-216-864-11	SHORT CHIP	0	R858	1-216-843-11	METAL CHIP	68K 5% 1/10W (GTR8/GTR8B)
		< COIL >		R886	1-245-711-31	CARBON	10 5% 1/2W (GTR7)
L830	1-420-872-52	COIL, AIR-CORE	(GTR7)	R889	1-216-825-11	METAL CHIP	2.2K 5% 1/10W (GTR8/GTR8B)
L880	1-420-872-52	COIL, AIR-CORE	(GTR7)	R889	1-216-826-11	METAL CHIP	2.7K 5% 1/10W (GTR7)
		< TRANSISTOR >					
Q821	8-729-040-76	TRANSISTOR KTA1273-Y-AT	(GTR7/GTR8: E2, E51, AR/GTR8B)				
Q822	8-729-620-07	TRANSISTOR 2SC3052EF-T1-LEF	(GTR7/GTR8: E2, E51, AR/GTR8B)				
Q824	8-729-620-07	TRANSISTOR 2SC3052EF-T1-LEF	(GTR7/GTR8: E2, E51, AR/GTR8B)				
Q825	8-729-620-07	TRANSISTOR 2SC3052EF-T1-LEF	(GTR7/GTR8: E2, E51, AR/GTR8B)				
Q800	8-729-924-99	TRANSISTOR 2SC3722K-E					
Q850	8-729-924-99	TRANSISTOR 2SC3722K-E					

# HCD-GTR6/GTR6B/GTR7/GTR8/GTR8B

Ver. 1.2

**SUBWOOFER**   **SW**   **TRANS**   **USB CD**

Ref. No.	Part No.	Description	Remark
R889	1-216-835-11	METAL CHIP 15K 5%	1/10W (GTR7)
R890	1-216-825-11	METAL CHIP 2.2K 5%	1/10W (GTR7)
R890	1-216-835-11	METAL CHIP 15K 5%	1/10W (GTR8/GTR8B)
R890	1-216-837-11	METAL CHIP 22K 5%	1/10W (GTR7/GTR8)
R891	1-216-848-11	METAL CHIP 180K 5%	1/10W (GTR8)
R891	1-216-850-11	METAL CHIP 270K 5%	1/10W (GTR7)
R893	1-216-841-11	METAL CHIP 47K 5%	1/10W (GTR7)
R804	1-217-637-55	FUSIBLE 1 5%	1/4W
R810	1-216-840-11	METAL CHIP 39K 5%	1/10W
R814	1-216-830-11	METAL CHIP 5.6K 5%	1/10W
R827	1-245-605-55	FUSIBLE 100 5%	1/4W
R828	1-245-605-55	FUSIBLE 100 5%	1/4W
R830	1-245-711-31	CARBON 10 5%	1/2W
R838	1-220-893-11	METAL 0.22 10%	5W
R841	1-216-845-11	METAL CHIP 100K 5%	1/10W
R860	1-216-841-11	METAL CHIP 47K 5%	1/10W
R867	1-246-024-21	METAL CHIP 150 5%	1/2W
R880	1-245-711-31	CARBON 10 5%	1/2W
R888	1-220-893-11	METAL 0.22 10%	5W
R891	1-216-845-11	METAL CHIP 100K 5%	1/10W
< RELAY >			
RY862	1-755-307-21	RELAY	
< TERMINAL >			
TB801	1-820-067-11	TERMINAL BOARD (SPEAKER, SUBWOOFER OUT RL)	(GTR8/GTR8B)
TB802	1-780-473-11	TERMINAL BOARD (SPEAKER) 1P (GTR7)	
*****			
SW BOARD *****			
< SWITCH >			
S751	1-786-514-11	SWITCH, LEVER (SLIDE) (OPEN/CLOSE ▲)	
*****			
TRANS BOARD *****			
< CAPACITOR >			
C1252	1-126-964-11	ELECT 10uF 20%	50V
C1253	1-128-563-11	ELECT 100uF 20%	100V
C1254	1-126-968-11	ELECT 100uF 20%	50V
C1255	1-126-767-11	ELECT 1000uF 20%	16V
< CONNECTOR >			
CN1250	1-564-528-11	PLUG, CONNECTOR 13P	
< DIODE >			
D1250	6-501-785-01	DIODE MAZ8200GMLS0	
D1251	6-501-788-01	DIODE MAZ8240GOLS0	
D1252	6-500-522-21	DIODE 10EDB40-TB3	
D1253	6-500-522-21	DIODE 10EDB40-TB3	

Ref. No.	Part No.	Description	Remark
D1254	6-500-522-21	DIODE 10EDB40-TB3	
D1255	6-500-522-21	DIODE 10EDB40-TB3	
D1256	6-500-522-21	DIODE 10EDB40-TB3	
< FUSE >			
F1271	1-523-087-11	FUSE 4A 250V (T4AL/250V)	
F1281	1-523-084-11	FUSE 2A 250V (T2AL/250V)	
< HOLDER, FUSE >			
FH1230	1-533-217-41	HOLDER, FUSE	
FH1232	1-533-217-41	HOLDER, FUSE	
FH1240	1-533-217-41	HOLDER, FUSE	
FH1242	1-533-217-41	HOLDER, FUSE	
FH1250	1-533-217-41	HOLDER, FUSE	
FH1252	1-533-217-41	HOLDER, FUSE	
FH1260	1-533-217-41	HOLDER, FUSE	
FH1262	1-533-217-41	HOLDER, FUSE	
< TRANSISTOR >			
Q1250	8-729-032-94	TRANSISTOR 2SD1859TV2Q	
< RESISTOR >			
R1250	1-216-821-11	METAL CHIP 1K 5%	1/10W
R1251	1-216-835-11	METAL CHIP 15K 5%	1/10W
R1271	1-219-124-55	FUSIBLE 0.68 5%	1/4W
*****			
USB CD BOARD *****			
< CAPACITOR >			
C1043	1-126-176-11	ELECT 220uF 20%	10V
C1044	1-164-360-11	CERAMIC CHIP 0.1uF	16V
C1045	1-126-176-11	ELECT 220uF 20%	10V
C1046	1-164-360-11	CERAMIC CHIP 0.1uF	16V
C1047	1-164-360-11	CERAMIC CHIP 0.1uF	16V
C1048	1-164-360-11	CERAMIC CHIP 0.1uF	16V
< CONNECTOR >			
CN1000	1-819-866-11	CONNECTOR, USB (A)	
CN1001	1-819-866-11	CONNECTOR, USB (A)	
< DIODE >			
D1020	6-501-691-01	DIODE 1L434FV22D0TDF01	
D1021	6-502-517-01	DI 1L434FB12E0MDTZ1	
D1022	6-502-517-01	DI 1L434FB12E0MDTZ1	
D1023	6-501-743-01	DIODE MAZ8068GMLS0	
D1024	6-501-743-01	DIODE MAZ8068GMLS0	
D1025	6-501-743-01	DIODE MAZ8068GMLS0	
D1026	6-500-848-01	DIODE MC2840-T112-1	
D1027	6-500-848-01	DIODE MC2840-T112-1	
D1030	6-500-848-01	DIODE MC2840-T112-1	
D1031	6-501-743-01	DIODE MAZ8068GMLS0	
D1032	6-500-848-01	DIODE MC2840-T112-1	
D1033	6-500-848-01	DIODE MC2840-T112-1	
D1034	6-501-743-01	DIODE MAZ8068GMLS0	
D1035	6-501-743-01	DIODE MAZ8068GMLS0	
D1038	6-500-848-01	DIODE MC2840-T112-1	

Ref. No.	Part No.	Description	Remark
< RESISTOR >			
R1041	1-216-819-11	METAL CHIP 680 5%	1/10W
R1043	1-216-819-11	METAL CHIP 680 5%	1/10W
R1045	1-216-819-11	METAL CHIP 680 5%	1/10W
R1046	1-216-839-11	METAL CHIP 33K 5%	1/10W
R1047	1-216-837-11	METAL CHIP 22K 5%	1/10W
< SWITCH >			
S1000	1-771-410-21	SWITCH, TACTILE (USB A)	
S1001	1-771-410-21	SWITCH, TACTILE (USB B)	
*****			
MISCELLANEOUS			
*****			
6	1-840-020-11	MECHA DECK (GTR6B/ GTR8B)	
13	1-827-995-11	WIRE (FLAT TYPE) (7 CORE) (GTR6B/GTR8B)	
14	1-827-720-11	WIRE (FLAT TYPE) (11 CORE)	
15	1-829-023-11	WIRE (FLAT TYPE) (23 CORE)	
53	1-828-938-51	WIRE (FLAT TYPE) (5 CORE)	
54	1-828-975-11	WIRE (FLAT TYPE) (13 CORE)	
55	1-828-384-11	WIRE (FLAT TYPE) (23 CORE)	
155	1-829-023-11	WIRE (FLAT TYPE) (23 CORE)	
△ 201	1-569-008-22	ADAPTOR, CONVERSION (E2, E51, E3)	
△ 202	1-777-071-83	CORD, POWER (E2, E51, E3)	
△ 202	1-829-259-11	CORD, POWER (AUS)	
△ 202	1-829-387-11	CORD, POWER (AR)	
203	3-703-244-00	CORD BUSH (2104) (EXCEPT MX)	
203	3-703-571-11	CORD BUSH (4516) (MX)	
204	1-457-369-12	CORE, FERRITE	
252	1-828-938-51	WIRE (FLAT TYPE) (5 CORE) (EXCEPT MX)	
252	1-776-182-11	WIRE (FLAT TYPE) (5 CORE) (MX)	
320	1-829-023-11	WIRE (FLAT TYPE) (23 CORE)	
△ F1231	1-533-949-33	FUSE, CYLINDRICAL (TIME LAG) (T8AL/250V)	
△ F1241	1-533-949-33	FUSE, CYLINDRICAL (TIME LAG) (T8AL/250V)	
△ F1251	1-533-949-33	FUSE, CYLINDRICAL (TIME LAG) (T8AL/250V)	
△ F1261	1-533-949-33	FUSE, CYLINDRICAL (TIME LAG) (T8AL/250V)	
M741	A-1108-955-A	MOTOR ASSY, TARLE	
M751	A-1108-966-A	MOTOR ASSY, LOADING (EXCEPT MX)	
M751	A-4737-553-A	MOTOR ASSY, LOADING (MX)	
M893	1-763-372-11	FAN, DC (GTR7/GTR8/GTR8B)	
M891	1-787-344-11	FAN, DC (GTR6/GTR6B)	
M892	1-787-344-11	FAN, DC (GTR7/GTR8/GTR8B)	
RE701	1-477-680-12	ENCODER, ROTARY (DISC TRAY ADDRESS DETECT)	
TU901	1-693-778-21	TUNER (FM/AM)	
△ PT1250	1-445-632-11	POWER TRANSFORMER (GTR6/GTR6B)	
△ PT1250	1-445-637-11	POWER TRANSFORMER (GTR8: E2, E51,AR/GTR8B)	
△ PT1250	1-445-640-11	POWER TRANSFORMER (GTR7:E2, E51, AR)	
△ PT1250	1-445-708-11	POWER TRANSFORMER (GTR7:MX)	
△ PT1250	1-445-709-11	POWER TRANSFORMER (GTR8:MX)	

