

HCD-MC1

SERVICE MANUAL

US Model
E Model



- This set is the tuner, deck, CD and amplifier section in MHC-MC1.

Manufactured under license from Dolby Laboratories Licensing Corporation.

“DOLBY” and the double-D symbol $\square\square$ are trademarks of Dolby Laboratories Licensing Corporation.

CD Section	Model Name Using Similar Mechanism	HCD-F150/FR10
	CD Mechanism Type	CDM-46B1
	Optical Pick-up Name	KSS-213BA/F-NP
Tape deck Section	Model Name Using Similar Mechanism	HCD-DR8AV
	Tape Transport Mechanism Type	TCM-230AWR2/230PWR2

SPECIFICATIONS

Amplifier section

U.S.A models:

AUDIO POWER SPECIFICATIONS

POWER OUTPUT AND TOTAL HARMONIC DISTORTION:

With 8 Ω loads both channels driven, from 70 – 20,000 Hz; rated 80 W per channel minimum RMS power, with no more than 0.9% total harmonic distortion from 250 mW to read output.

Continuous RMS power output
80 + 80 W(8 Ω at 1kHz, 10% THD)

Total harmonic distortion
less than 0.09%(8 Ω at 1kHz, 40W)

Inputs

VIDEO/MD IN (phono jack):
voltage 250mV/450mV,
impedance 47k Ω

Outputs

VIDEO/MD OUT (phono jack):
voltage 250mV,
impedance 1k Ω

PHONES (stereo phone jacks):

accepts headphones of 8 Ω or more

SPEAKER : accepts impedance of 8 to 16 Ω

REAR SPEAKER :

accepts impedance of 16 Ω

SUPER WOOFER :

Voltage 1V, impedance 1k Ω

CD player section

System Compact disc and digital audio system
Laser Semiconductor laser ($\lambda = 780\text{nm}$)
Emission duration:
continuous

Laser output

Max. 44.6 μW *

*This output is the value measured at a distance of 200 mm from the objective lens surface on the Optical Pick-up Block with 7 mm aperture.

Frequency response

2Hz – 20kHz ($\pm 0.5\text{dB}$)

Wavelength

780 – 790nm

Signal-to-noise ratio

More than 90dB

Dynamic range

More than 90dB

CD OPTICAL DIGITAL OUT

(Square optical connector jack, rear panel)

Output Level –18dBm

Tape player section

Recording system 4-track 2-channel stereo

Frequency response (DOLBY NR OFF)

40 – 13,000Hz ($\pm 3\text{dB}$),

using Sony TYPE I

cassette

40 – 14,000Hz ($\pm 3\text{dB}$),

using Sony TYPE II

cassette

Tuner section

FM stereo, FM/AM superheterodyne tuner

FM tuner section

Tuning range 87.5 – 108.0MHz

Antenna FM lead antenna

Antenna terminals 75 Ω unbalanced

Intermediate frequency 10.7MHz

— Continued on next page —

MINI HI-FI COMPONENT SYSTEM



SONY®

6-4. SCHEMATIC DIAGRAM BD SECTION • See page 71 for Waveforms. • See page 72 for IC Pin Functions.

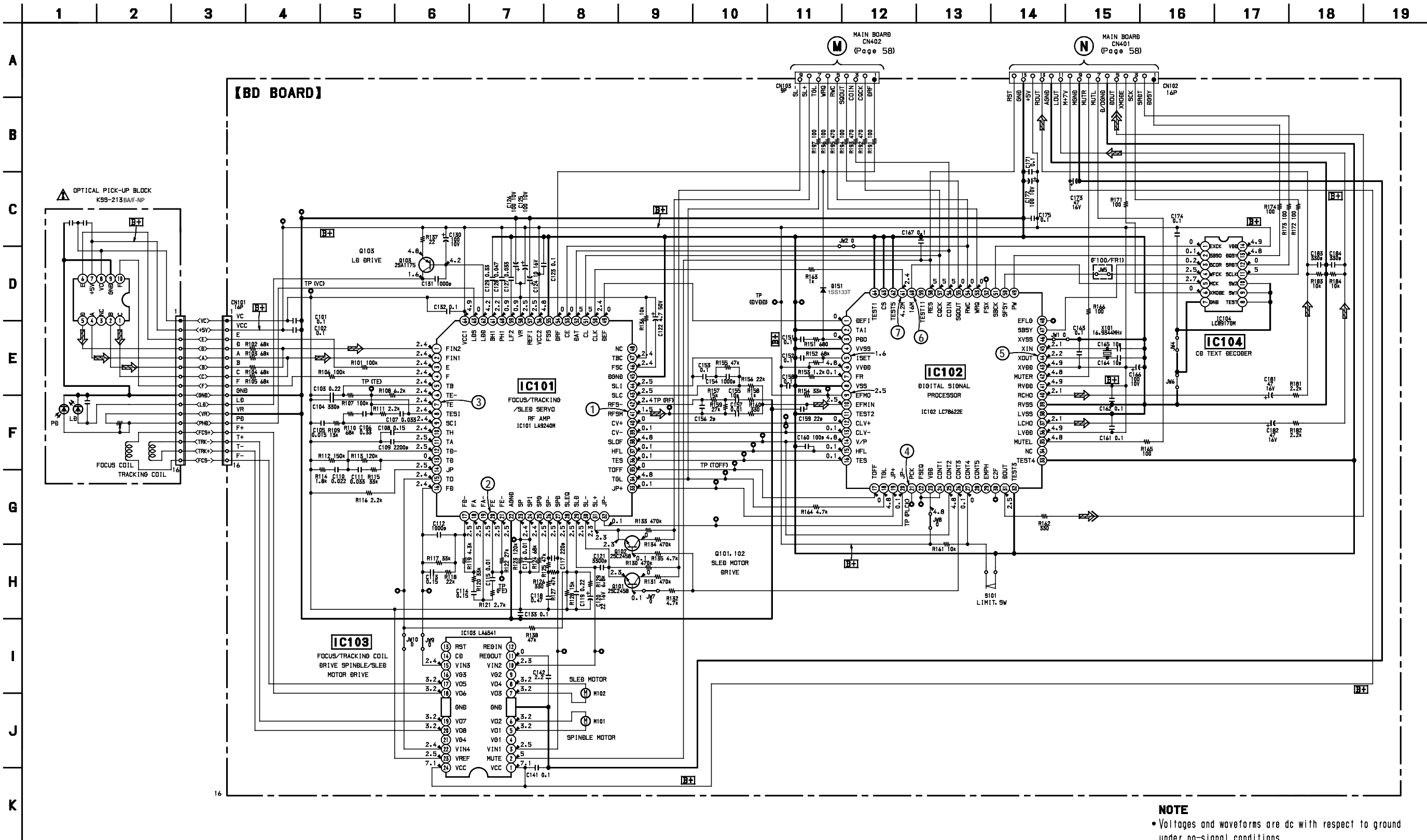

NOTE
 • Voltages and waveforms are dc with respect to ground under no-signal conditions, no mark: CD

The components identified by mark Δ or dotted line with mark Δ are critical for safety. Replace only with part number specified.

6-6. SCHEMATIC DIAGRAM CD MOTOR SECTION

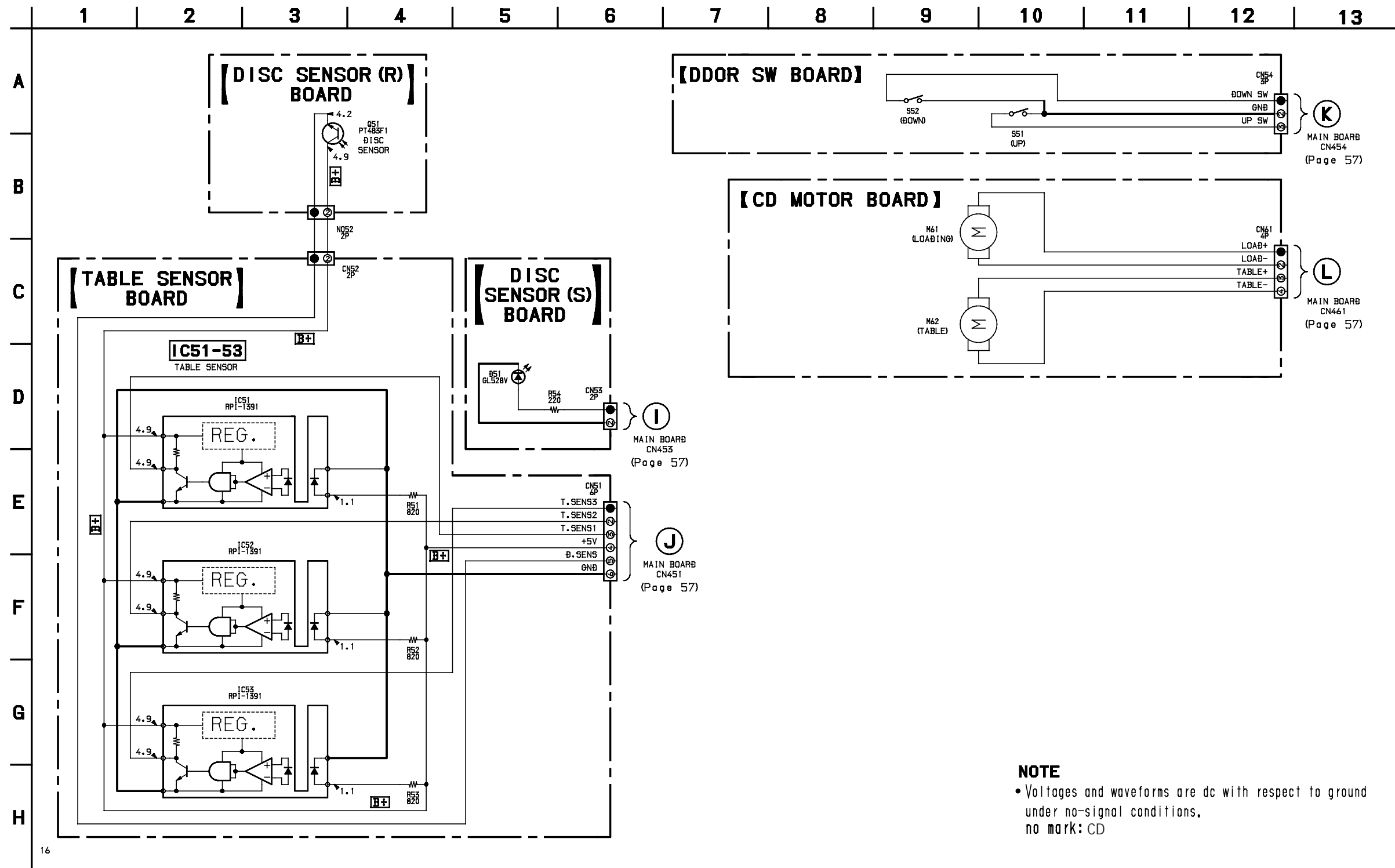

NOTE
 • Voltages and waveforms are dc with respect to ground under no-signal conditions.
 no mark: CD

6-8. SCHEMATIC DIAGRAM AUDIO SECTION • See page 80 for IC Block Diagrams.

	1	2	3	4	5	6	7	8	9	10	11	12	13
--	---	---	---	---	---	---	---	---	---	----	----	----	----

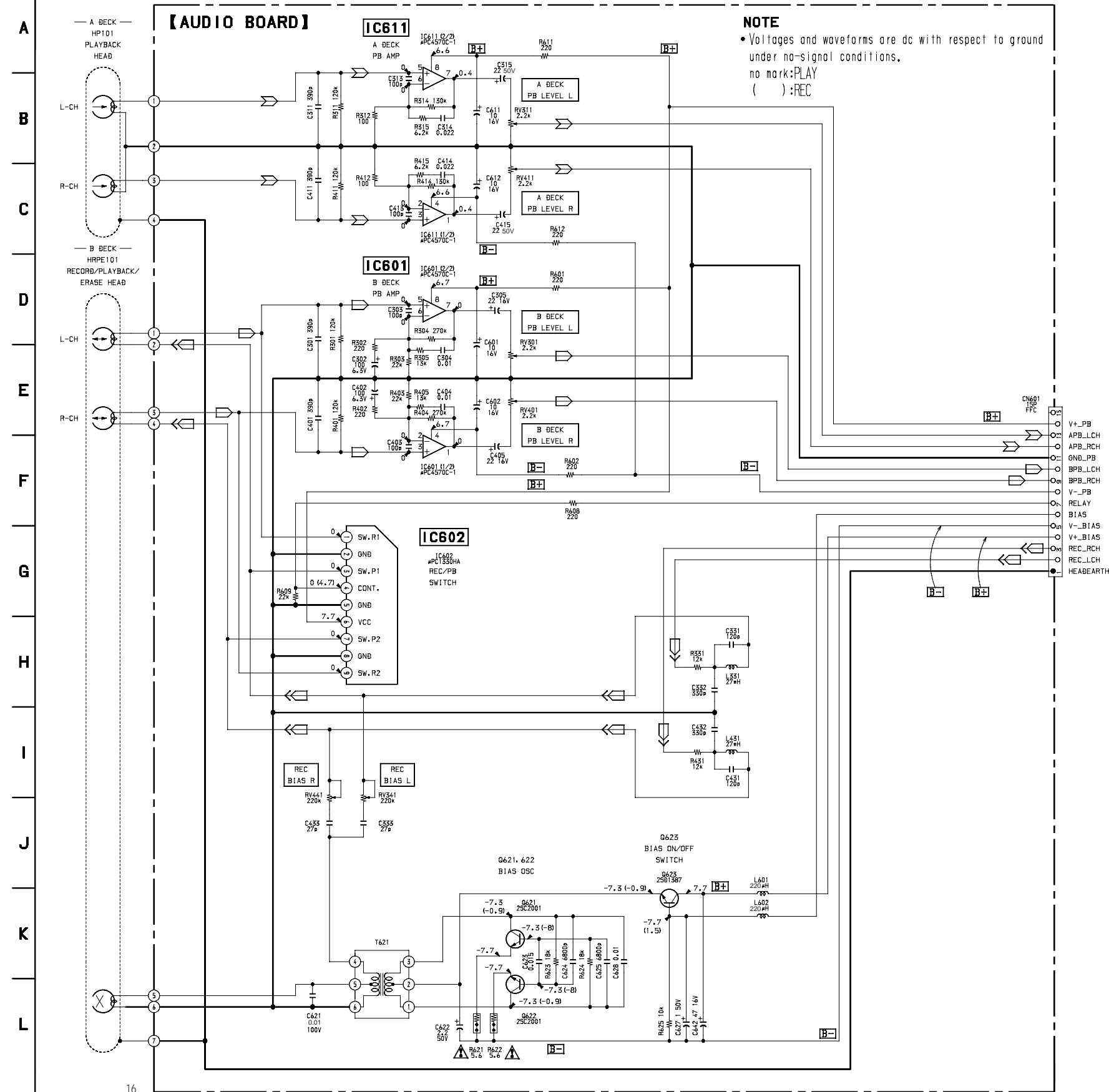

The components identified by mark \triangle or dotted line with mark \triangle are critical for safety. Replace only with part number specified.

6-10. SCHEMATIC DIAGRAM LEAF SW SECTION

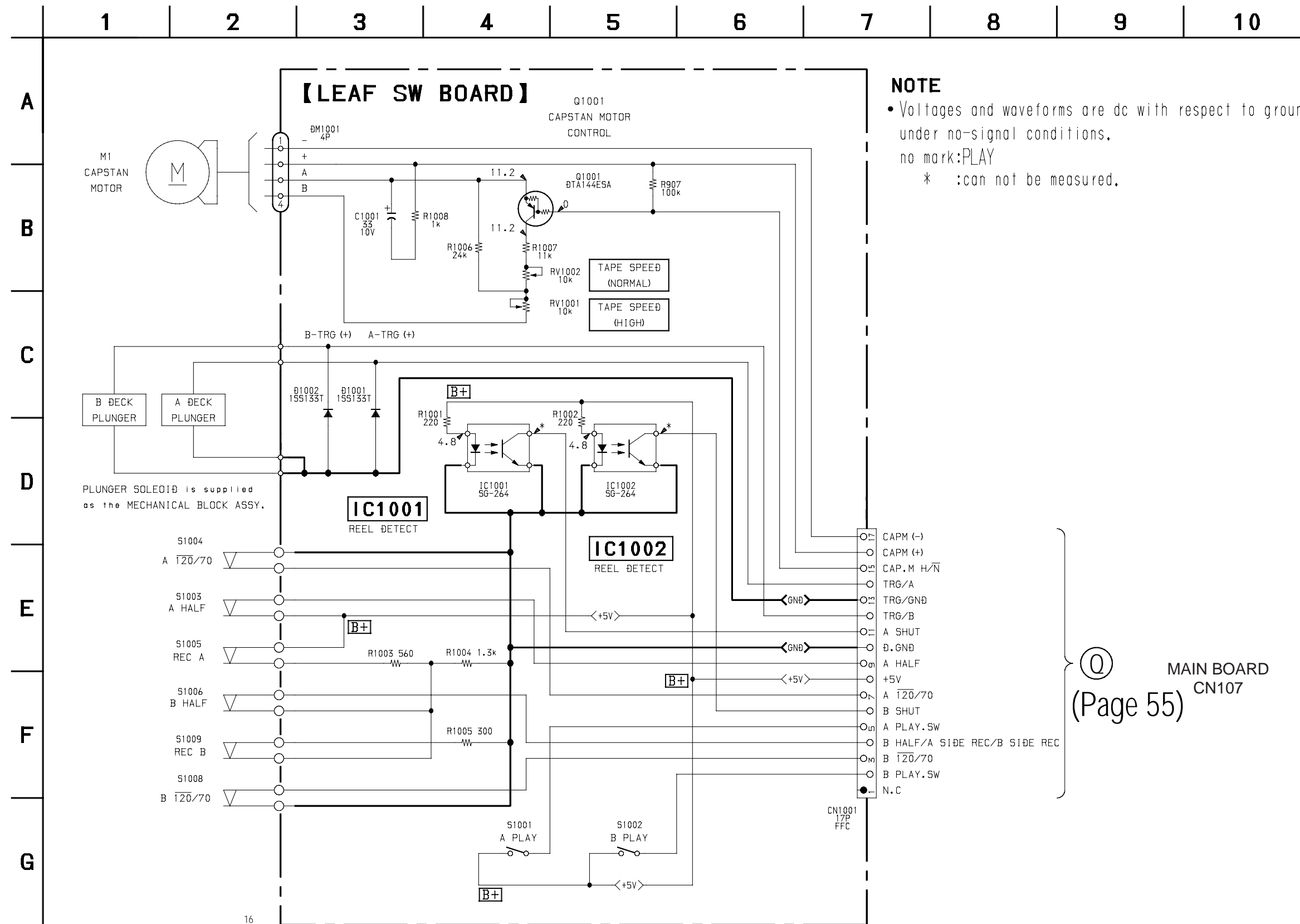

6-12. SCHEMATIC DIAGRAM MAIN (1/5) SECTION

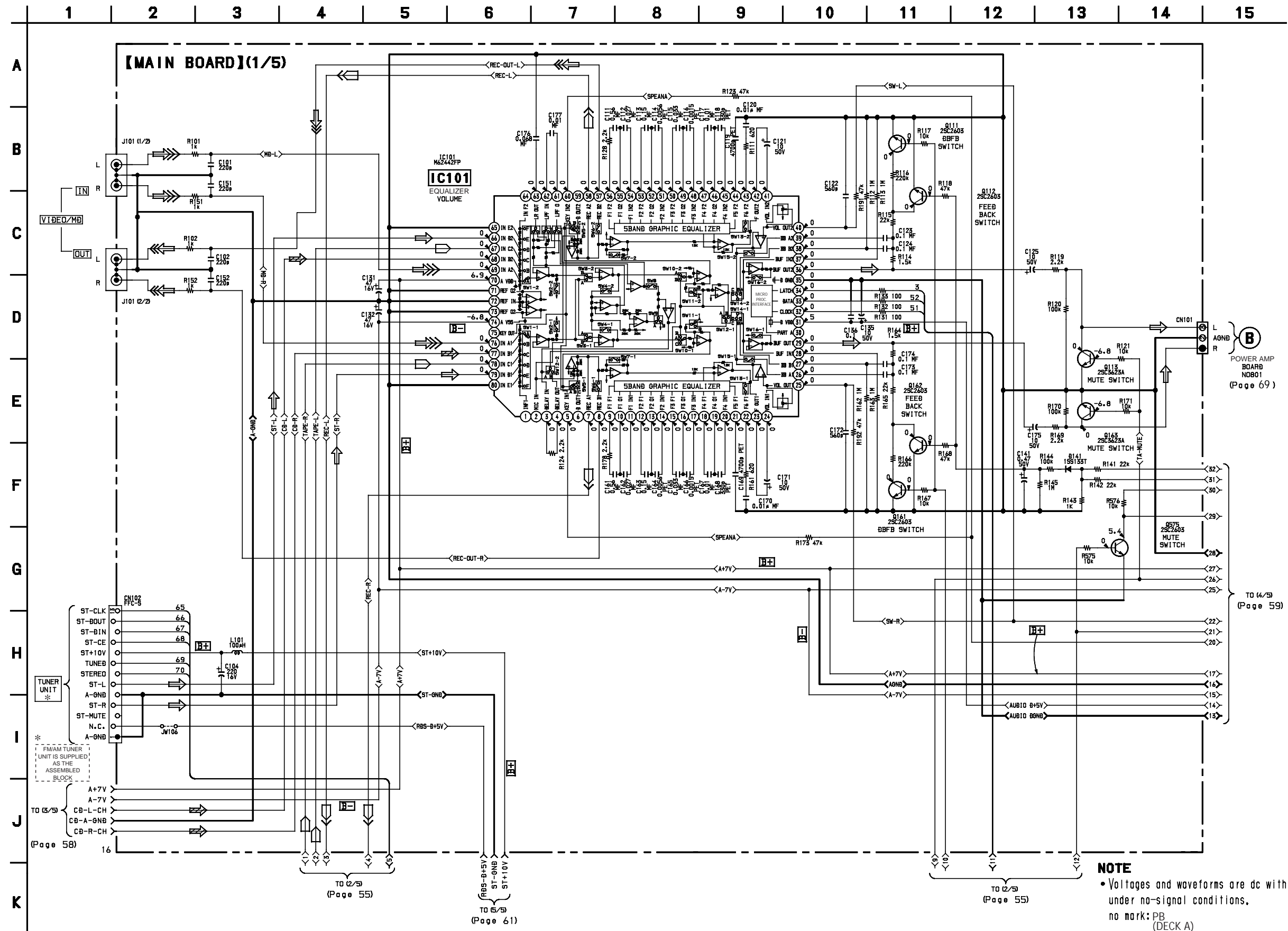

6-13. SCHEMATIC DIAGRAM MAIN (2/5) SECTION • See page 51 for Printed Wiring Board. • See page 71 for Waveforms. • See page 77 for IC Pin Functions.

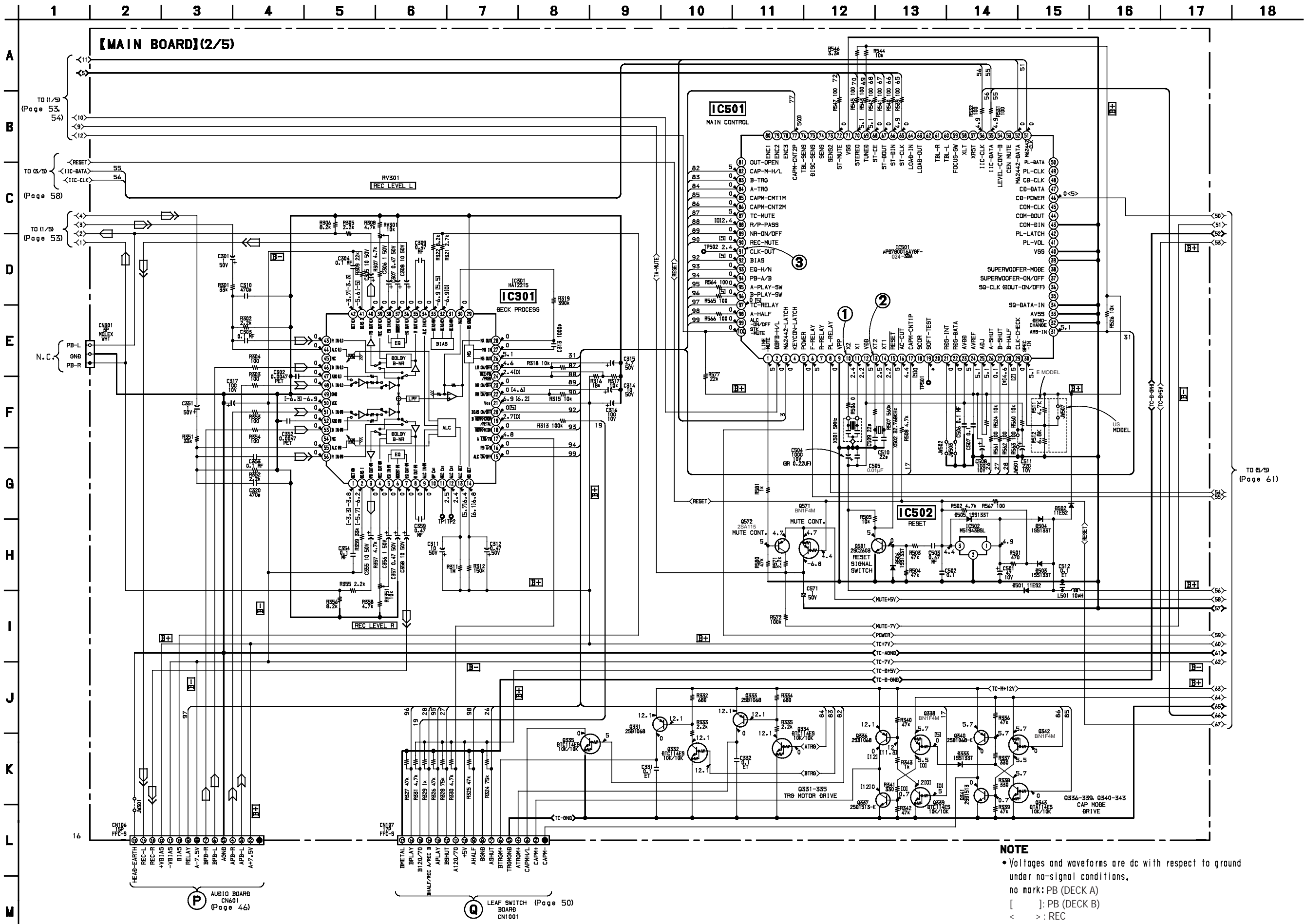

6-14. SCHEMATIC DIAGRAM MAIN (3/5) SECTION • See page 51 for Printed Wiring Board. • See page 71 for Waveforms. • See page 56 for IC Pin Functions.

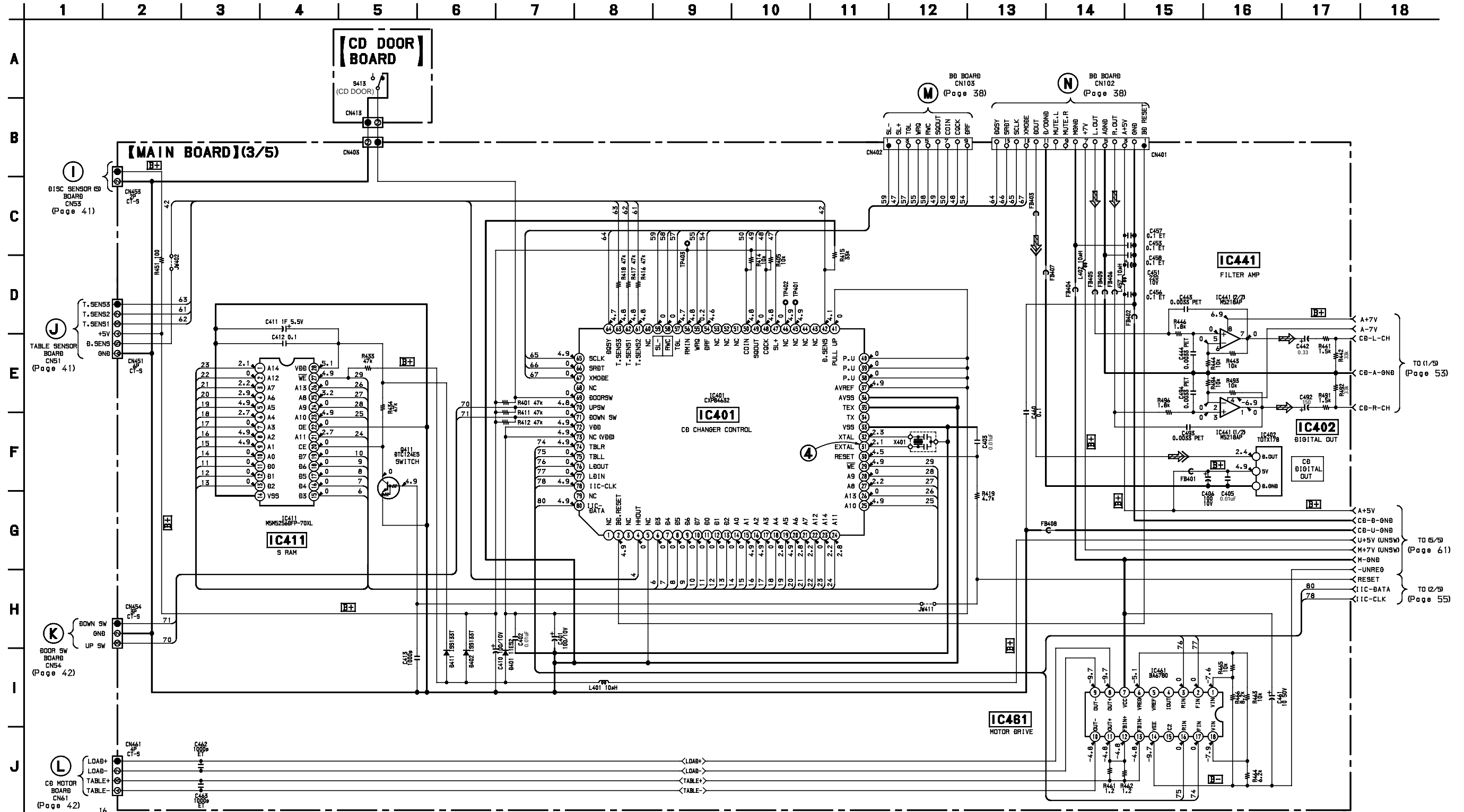

NOTE
 • Voltages and waveforms are dc with respect to ground under no-signal conditions.
 no mark:CD

6-15. SCHEMATIC DIAGRAM MAIN (4/5) SECTION • See page 51 for Printed Wiring Board. • See page 80 for IC Block Diagrams.

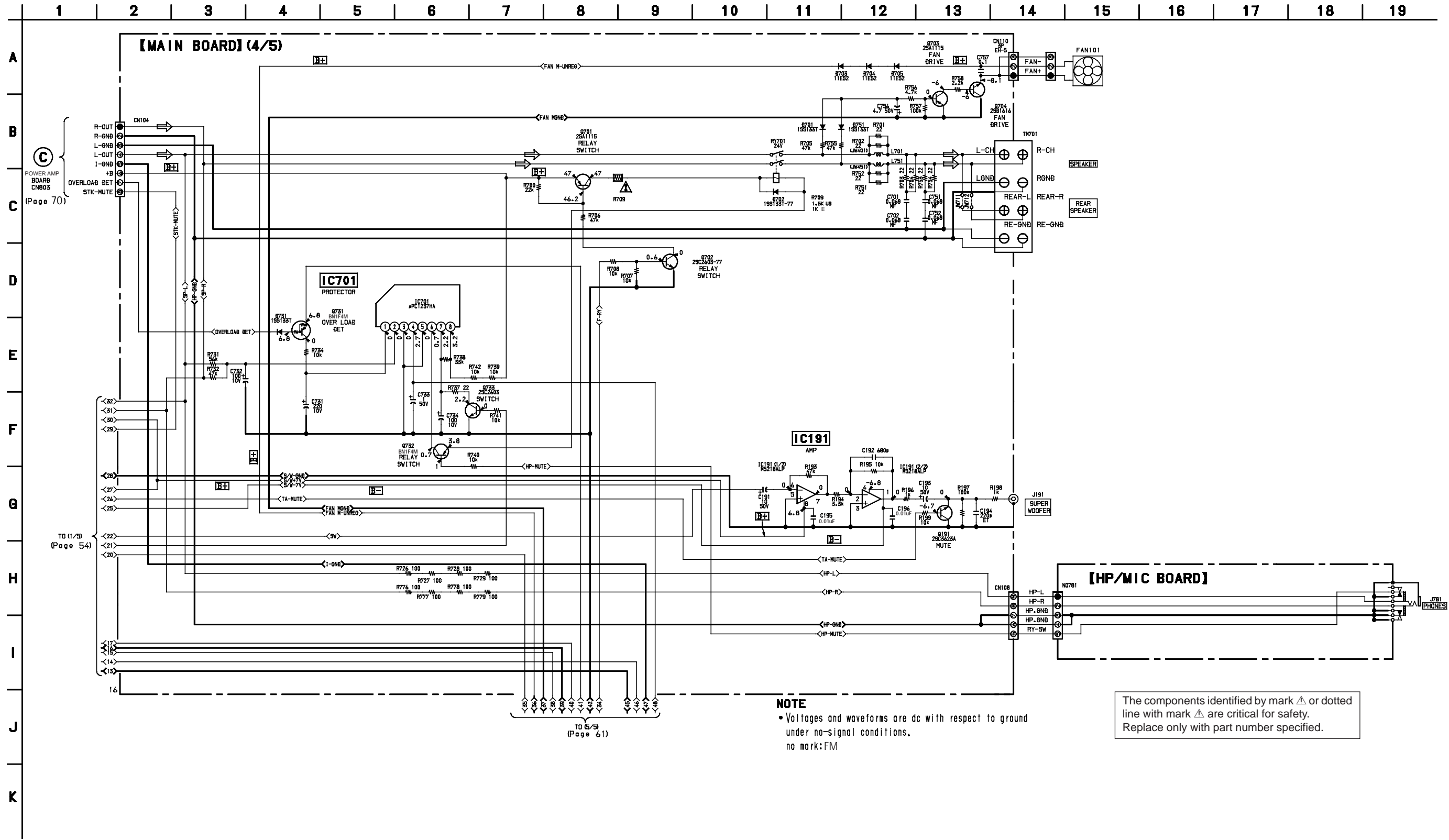

NOTE
 • Voltages and waveforms are dc with respect to ground under no-signal conditions.
 no mark:FM

The components identified by mark Δ or dotted line with mark Δ are critical for safety. Replace only with part number specified.

6-16. SCHEMATIC DIAGRAM MAIN (5/5) SECTION • See page 51 for Printed Wiring Board.

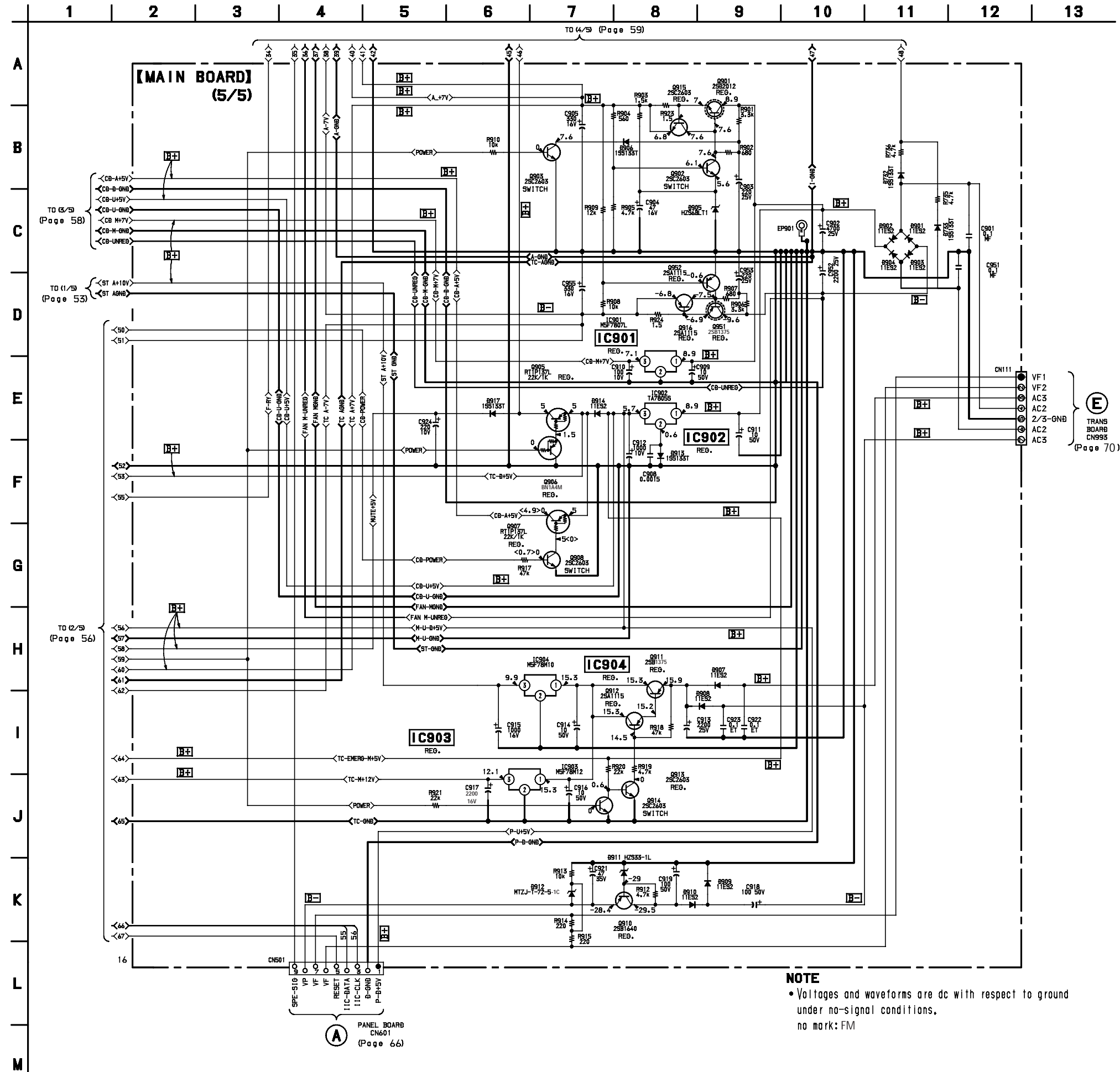

6-18. SCHEMATIC DIAGRAM PANEL SECTION • See page 80 for IC Block Diagrams. • See page 71 for Waveforms. • See page 79 for IC Pin Function Description.

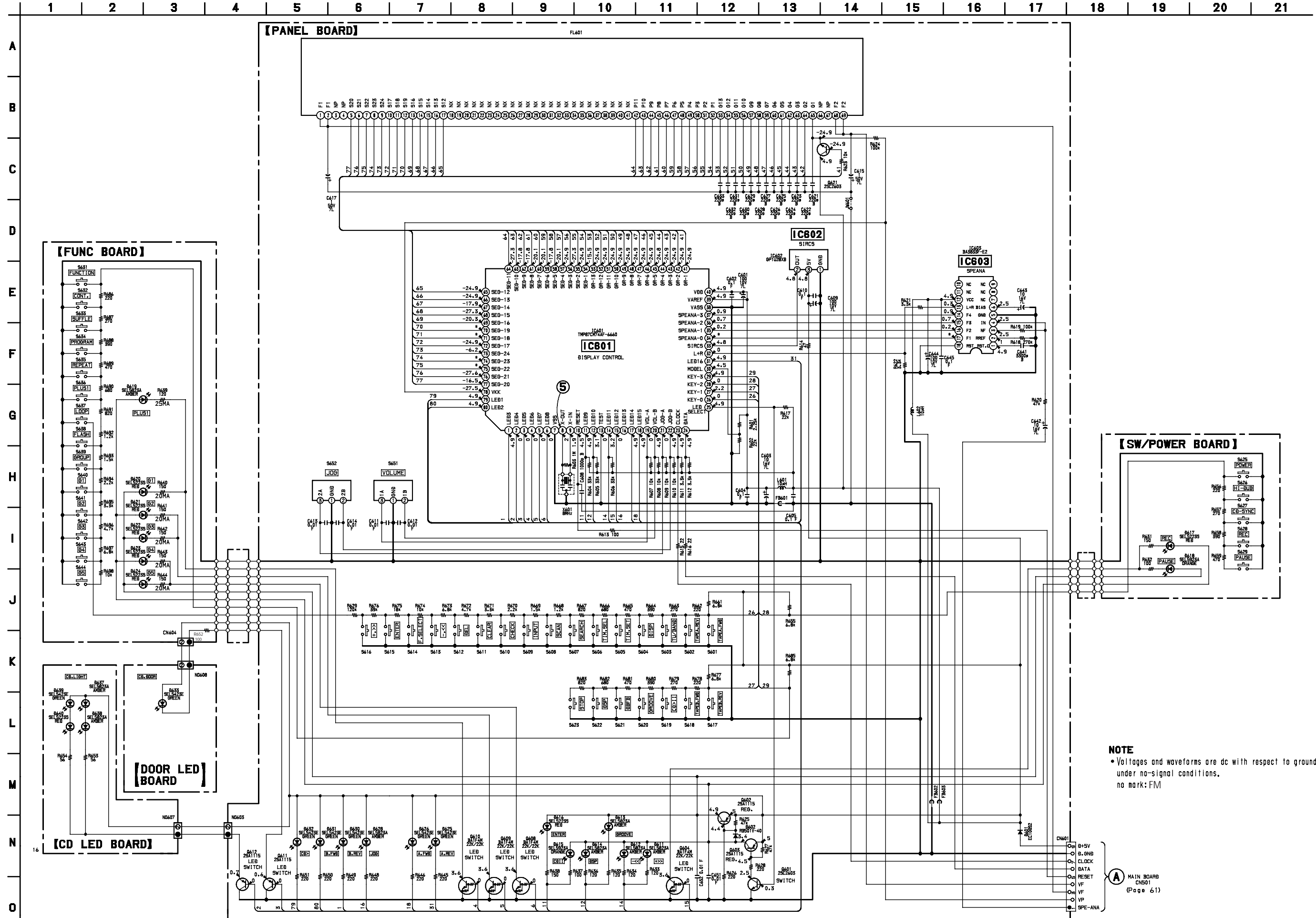

NOTE
 • Voltages and waveforms are dc with respect to ground under no-signal conditions, no mark: FM

A MAIN BOARD
 CN501
 (Page 61)

6-20. SCHEMATIC DIAGRAM POWER SECTION

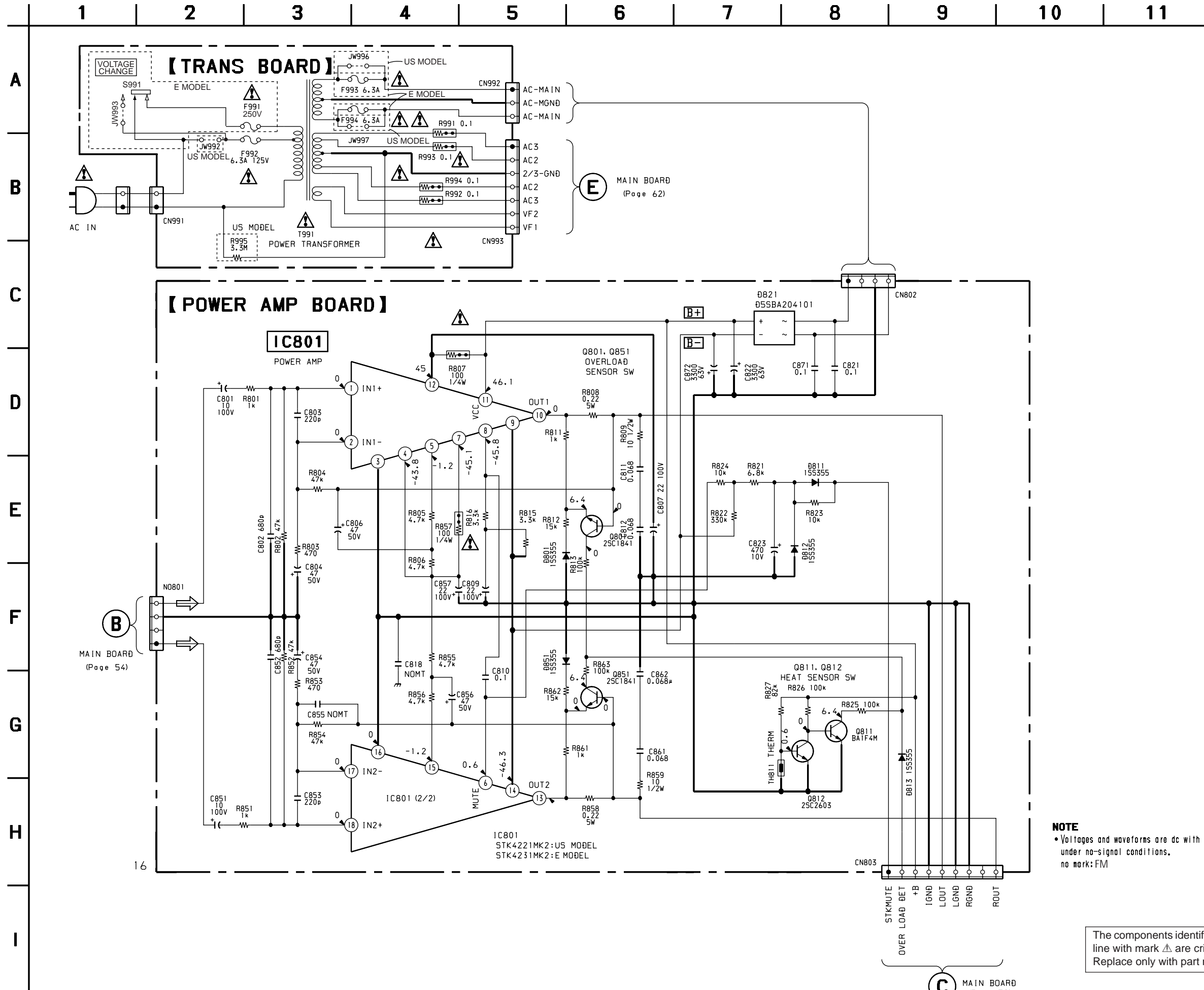

NOTE
 • Voltages and waveforms are dc with respect to ground under no-signal conditions.
 no mark: FM

The components identified by mark \triangle or dotted line with mark \triangle are critical for safety. Replace only with part number specified.

6-23. IC BLOCK DIAGRAMS

IC603 (PANEL BOARD) BA3833F-E2

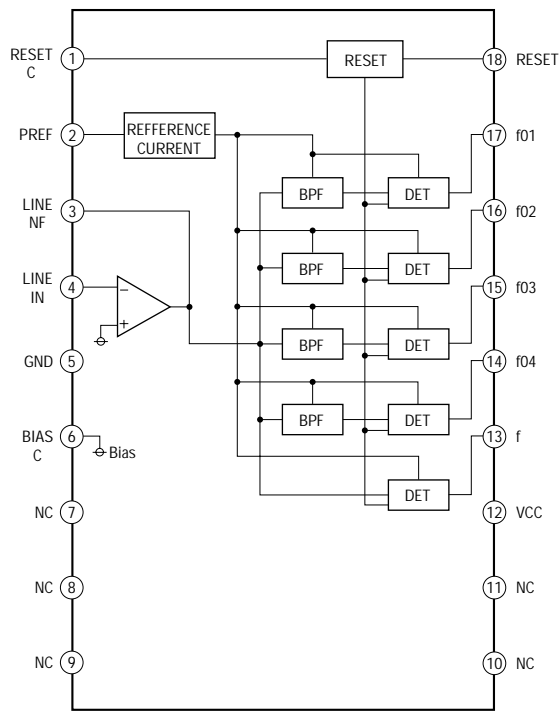

IC461 (MAIN BOARD) BA6780

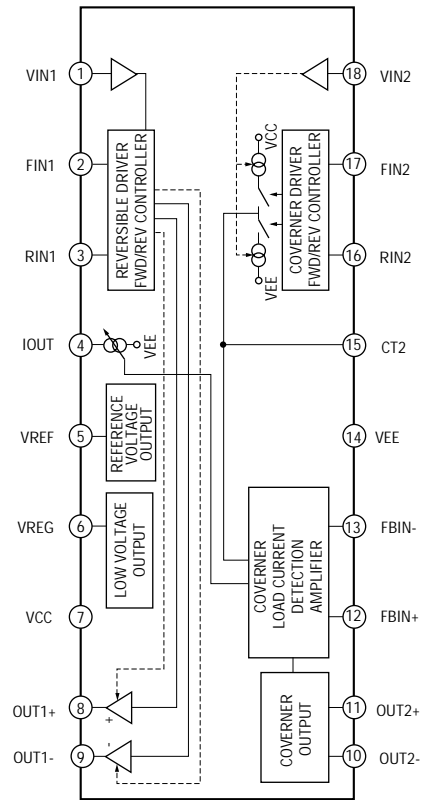

IC602 (AUDIO BOARD) uPC1330HA

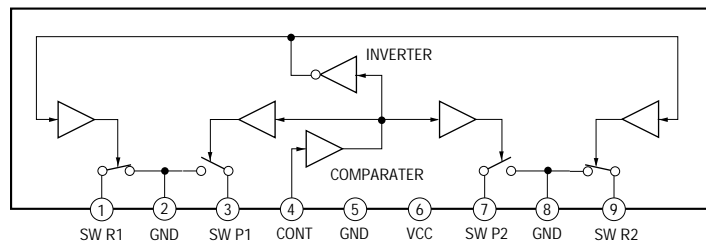

IC701 (MAIN BOARD) UPC1237HA

