

## Over voltage and over current protection IC

### Description

The HCP4803 is an Over-Voltage-Protection (OVP) and Over-Current-Protection (OCP) device. The device will switch off internal MOSFET to disconnect IN to OUT to protect load when any of input voltage, input current over the threshold. The Over temperature protection (OTP) function monitors chip temperature to protect the device.

### Application

- PAD
- GPS
- MID
- PMP
- Digital Cameras
- Digital Videos

### Features

- High voltage technology
- Maximum input voltage :25V
- Output power ON time :8ms(Typ.)
- OVP threshold :6.1V(Typ.)
- OVP response time :<1us
- OCP threshold :2A(Min.)
- Output auto discharge
- Small Package :SOT-23-6L

### Ordering information

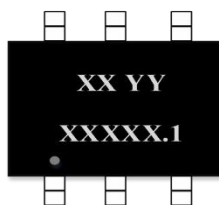

XX YY: Date code

XXXXX.1: Wafer batch

**Fig.1** Top view



**Table 1**

Package	SOT-23-6L
MOQ	3000 pcs

## Typical Application

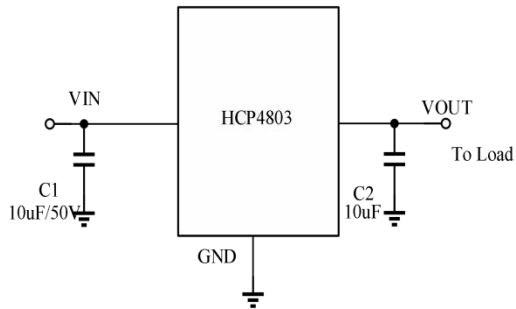
**Fig.2**

## Pin Configuration and Function

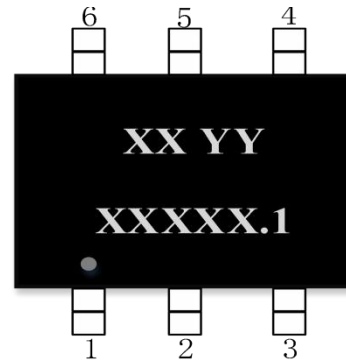
**Fig.3** Pin configuration (Top view)

**Table 2**

NO.	Symbol	Type	Description
1/2/5/6	GND	GROUND	Ground
3	VIN	POWER	Input pin. A 10uF low ESR ceramic capacitor or larger must be connected as close as to this pin. It is recommended to use 50V capacitor or according to application.
4	VOUT	OUTPUT	Output pin, Connect to load.

## Functional Block Diagram

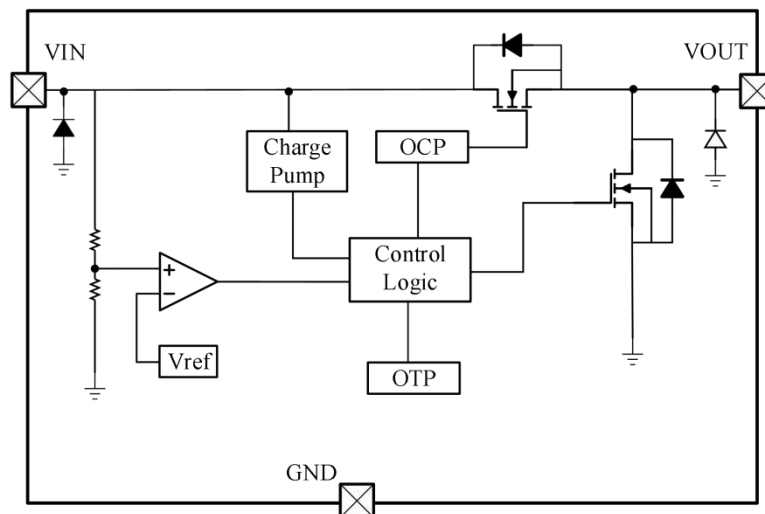
**Fig.4**

## Absolute Maximum Ratings

**Table 3**

Parameter	Symbol	Value	Unit
Input voltage (IN pin)	V <sub>IN</sub>	-0.3 ~ 25	V
Output voltage (OUT pin)	V <sub>OUT</sub>	-0.3 ~ 6.5	V
Power dissipation *1 *3	P <sub>D</sub>	0.5	W
Power dissipation *2 *3		0.3	W
Thermal resistance *1	R <sub>θJA</sub>	250	°C/W
Thermal resistance *2		416	°C/W
Junction temperature	T <sub>J</sub>	150	°C
Lead temperature(10s)	T <sub>L</sub>	260	°C
Storage temperature	T <sub>stg</sub>	-55 ~ 150	°C
ESD Ratings	HBM	±8000	V
	MM	±1000	V

**Note:** These are stress ratings only. Stresses exceeding the range specified under “Absolute Maximum Ratings” may cause substantial damage to the device. Functional operation of this device at other conditions beyond those listed in the specification is not implied and prolonged exposure to extreme conditions may affect device reliability.

\*1: Surface mounted on FR-4 Board using 1 square inch pad size, dual side, 1oz copper

\*2: Surface mounted on FR-4 board using minimum pad size, 1oz copper

\*3: Power dissipation is calculated by  $P_D = (V_{IN} - V_{OUT}) \times I_{OUT}$

## Recommend Operating Conditions

**Table 4** (T<sub>a</sub>=25°C, unless otherwise noted)

Parameter	Symbol	Value	Unit
Input voltage	V <sub>IN</sub>	3 ~ 40	V
Output current	I <sub>OUT</sub>	1.5	A
Ambient operating temperature	T <sub>opr</sub>	-40 ~ 85	°C

## Electrical Characteristics

**Table 5**

Parameter	Symbol	Test conditions	Min.	Typ.	Max.	Unit
<b>DC characteristics and Power-ON-Reset</b>						
Input quiescent current	$I_Q$	$V_{IN} = 5V, I_{OUT} = 0A$		280	350	$\mu A$
IN-to-OUT ON resistance *3	$R_{ON}$	$V_{IN} = 5V, I_{OUT} = 0.7A$		150	250	$m\Omega$
Output discharge resistance	$R_{DISCHARGE}$			500		$\Omega$
Under voltage lock out threshold	UVLO	$V_{IN}$ increasing from 0~3V	2.3		2.8	V
Under voltage lock out hysteresis	$V_{HYS-UVLO}$	$V_{IN}$ decreasing from 3~0V	200	250	300	mV
Output power-on time	$T_{ON}$	$V_{IN} = 0 \rightarrow 5V$ to output ON	6	8	10	ms
<b>Input Over-Voltage-Protection (OVP)</b>						
OVP threshold	$V_{OVP}$	$V_{IN}$ increasing from 5~7V	5.8	6.1	6.4	V
OVP hysteresis	$V_{HYS-OVP}$	$V_{IN}$ decreasing from 7~5V	200	300	400	mV
OVP active time	$T_{OVP}$	$V_{IN} = 5 \rightarrow 10V$			1	$\mu s$
OVP recovery time	$T_{ON(OVP)}$	$V_{IN} = 10 \rightarrow 5V$ to output ON	6	8	10	ms
<b>Input Over-Current-Protection (OCP)</b>						
OCP threshold	$I_{OCP}$		2.0			A
<b>Over-Temperature-Protection (OTP)</b>						
OTP threshold				165		$^{\circ}C$
OTP hysteresis				40		$^{\circ}C$

\*3: Single Pulse, Pulse width=10ms

### Typical characteristics

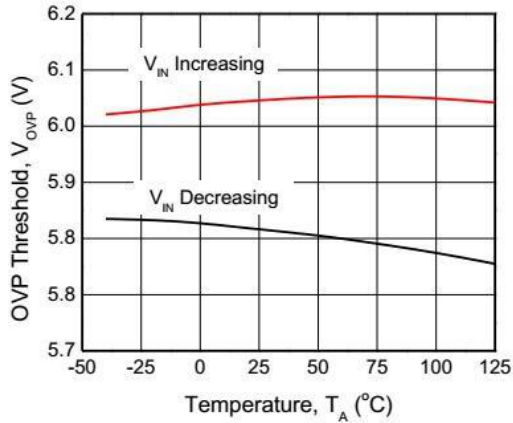

OVP threshold vs. Temperature

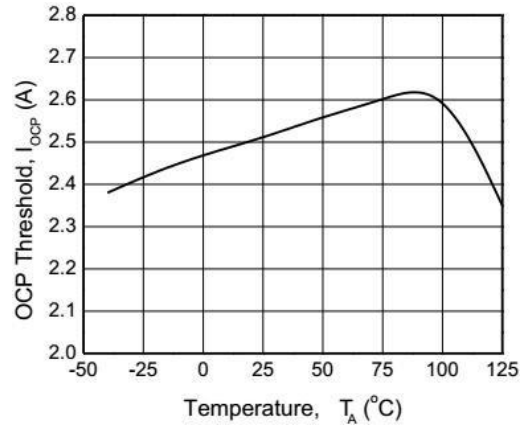

OCP threshold vs. Temperature

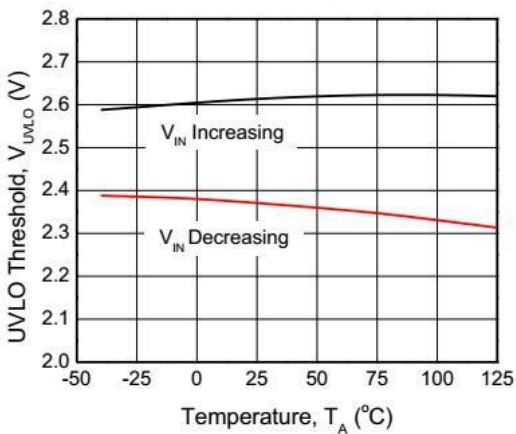

UVLO threshold vs. Temperature

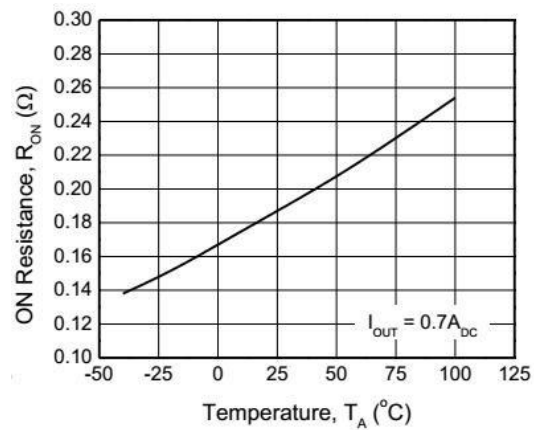

IN-to-OUT ON resistance vs. Temperature

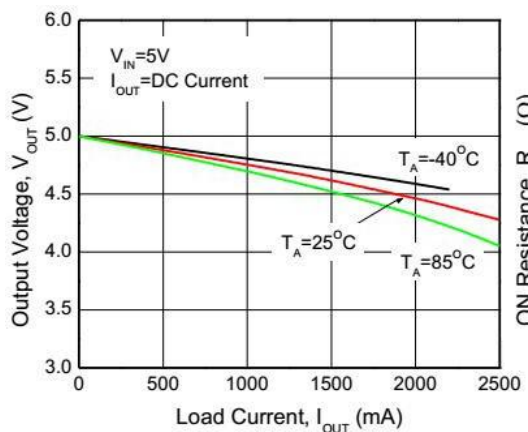

Output voltage vs. Output current

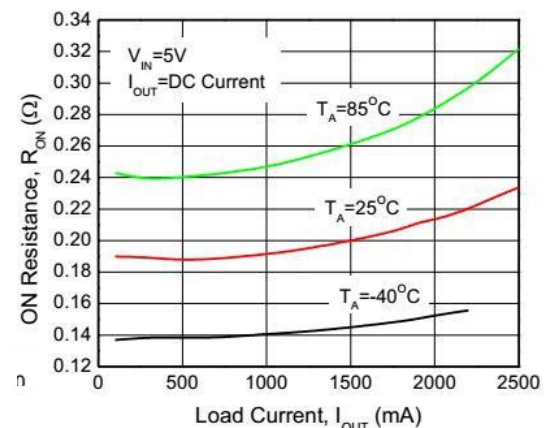

ON resistance vs. Output current

## Typical Application

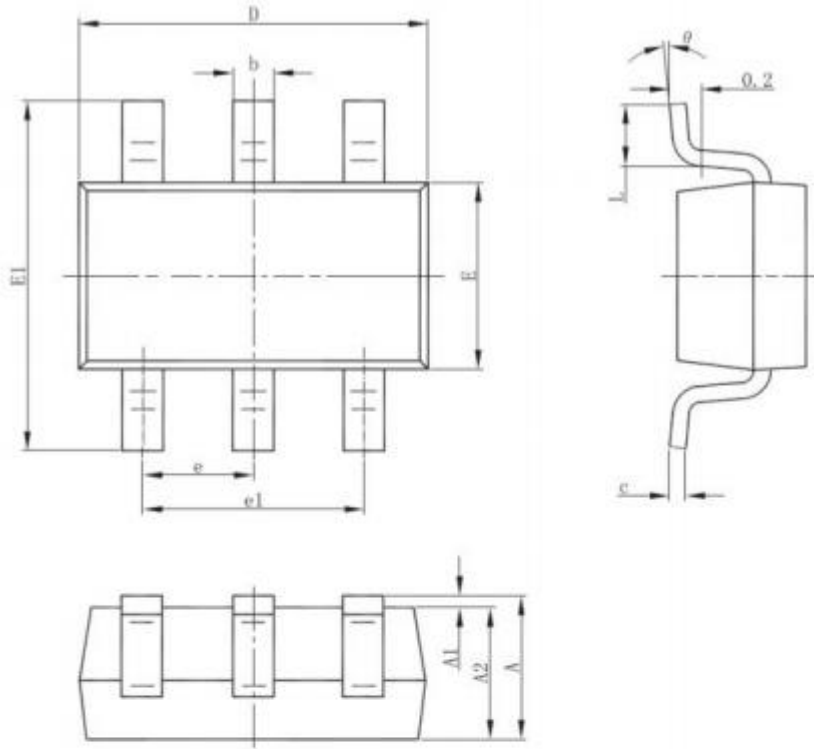
**Fig. 5 Package outline**
**Table 6**

Symbol	Min (mm)	Type(mm)	Max(mm)
A	1.050	-	1.250
A1	0.000	-	0.100
A2	1.050	-	1.150
b	0.300	0.400	0.500
c	0.100	-	0.200
D	2.820	2.900	3.020
E	1.500	1.600	1.700
E1	2.650	2.800	2.950
e	0.950Typ.		
e1	1.800	1.900	2.000
L	0.300	-	0.600
$\theta$	0°	-	8°