

HCPL-0708

High Speed CMOS Optocoupler



Data Sheet



Description

Available in SO-8 package, the HCPL-0708 optocoupler utilizes the latest CMOS IC technology to achieve outstanding performance with very low power consumption. Basic building blocks of the HCPL-0708 are a high speed LED and a CMOS detector IC. The detector incorporates an integrated photodiode, a high-speed trans-impedance amplifier, and a voltage comparator with an output driver.

Functional Diagram

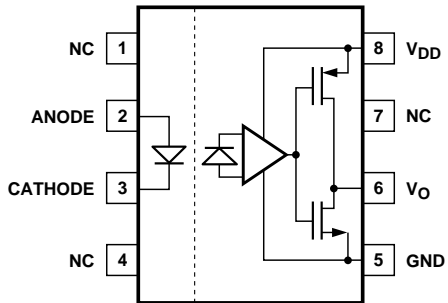

TRUTH TABLE

LED	V _O , OUTPUT
OFF	H
ON	L

**A 0.1 μF bypass capacitor must be connected between pins 5 and 8.*

Features

- +5 V CMOS compatibility
- 15 ns typical pulse width distortion
- 30 ns max. pulse width distortion
- 40 ns max. propagation delay skew
- High speed: 15 MBd
- 60 ns max. propagation delay
- 10 kV/μs minimum common mode rejection
- -40 to 100°C temperature range
- Safety and regulatory approvals pending
 - UL recognized
3750 V rms for 1 min. per UL 1577 for HCPL-0708
 - CSA component acceptance Notice #5
 - IEC/EN/DIN EN 60747-5-2
approved for HCPL-0708 Option 060

Applications

- Scan drive in PDP
- Digital field bus isolation: DeviceNet, SDS, Profibus
- Multiplexed data transmission
- Computer peripheral interface
- Microprocessor system interface
- DC/DC converter

CAUTION: It is advised that normal static precautions be taken in handling and assembly of this component to prevent damage and/or degradation which may be induced by ESD.

Ordering Information

HCPL-0708 is UL Recognized with 3750 Vrms for 1 minute per UL1577.

Part Number	Option		Package	Surface Mount	Gull Wing	Tape & Reel	UL 5000 Vrms/ 1 Minute rating	IEC/EN/DIN EN 60747-5-2	Quantity
	RoHS Compliant	non RoHS Compliant							
HCPL-0708	-000E	no option	SO-8						100 per tube
	-500E	-500		X	X	X			1500 per reel
	-060E	-060						X	100 per tube
	-560E	-560		X	X	X		X	1500 per reel

To order, choose a part number from the part number column and combine with the desired option from the option column to form an order entry.

Example 1:

HCPL-0708-500E to order product of Small Outline SO-8 package in Tape and Reel packaging and RoHS compliant.

Example 2:

HCPL-0708 to order product of Small Outline SO-8 package in Tube packaging and non RoHS compliant.

Option datasheets are available. Contact your Avago sales representative or authorized distributor for information.

Remarks: The notation '#XXX' is used for existing products, while (new) products launched since July 15, 2001 and RoHS compliant will use '-XXXE.'

Package Outline Drawing

HCPL-0708 (Small Outline SO-8 Package)

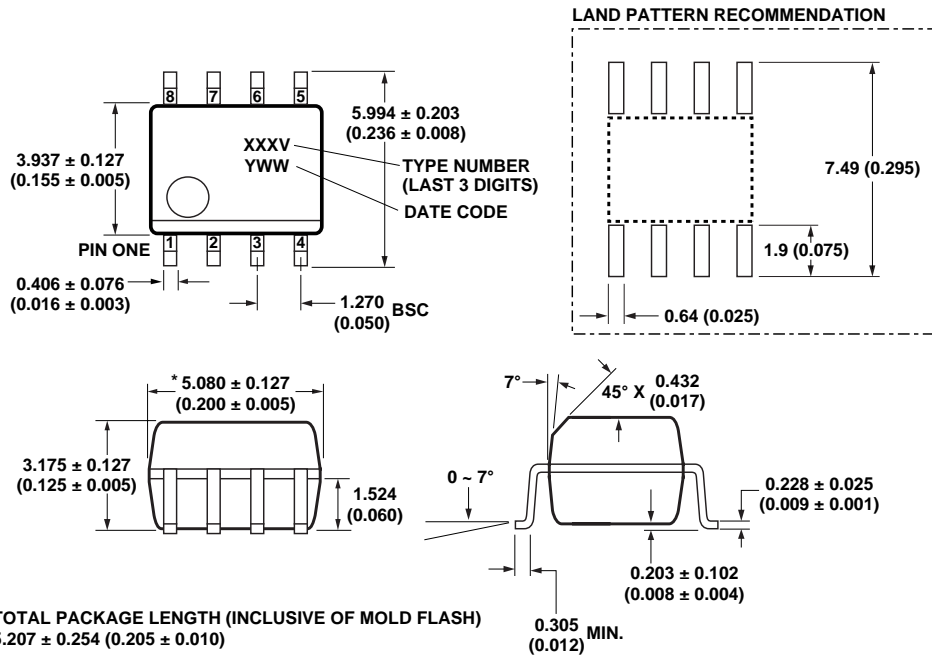

* TOTAL PACKAGE LENGTH (INCLUSIVE OF MOLD FLASH)
 5.207 ± 0.254 (0.205 ± 0.010)

DIMENSIONS IN MILLIMETERS (INCHES).
 LEAD COPLANARITY = 0.10 mm (0.004 INCHES) MAX.

OPTION NUMBER 500 NOT MARKED.

NOTE: FLOATING LEAD PROTRUSION IS 0.15 mm (6 mils) MAX.

Solder Reflow Thermal Profile

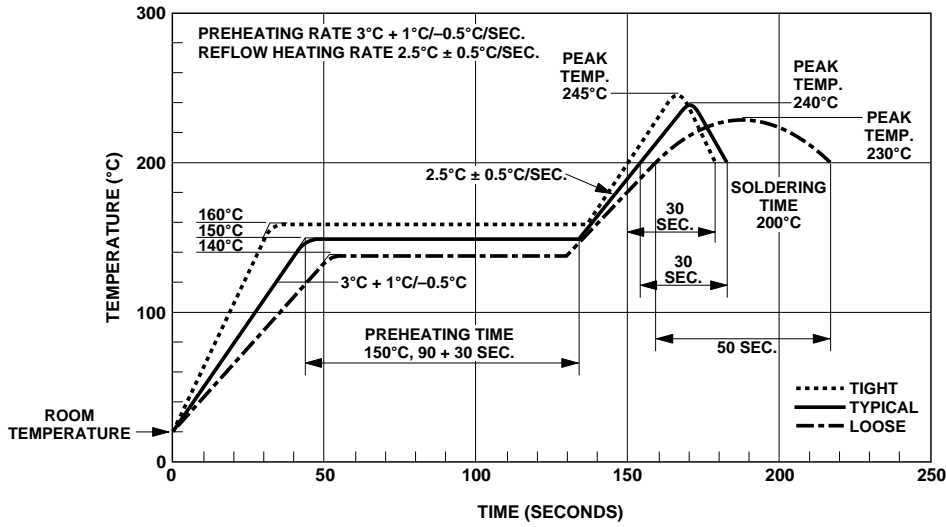

Note: Non-halide flux should be used.

Recommended Pb-Free IR Profile

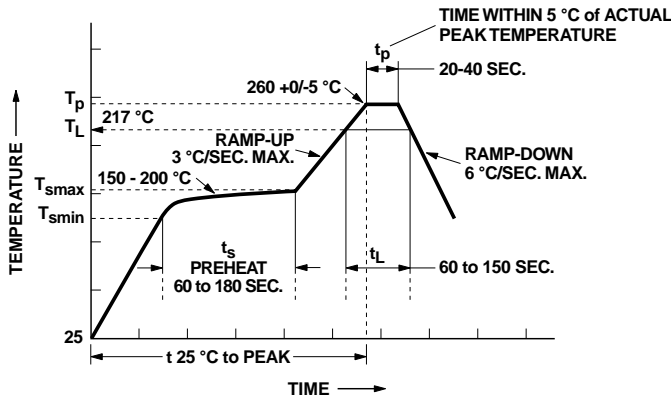

NOTES:
 THE TIME FROM 25°C TO PEAK TEMPERATURE = 8 MINUTES MAX.
 $T_{smax} = 200^{\circ}\text{C}$, $T_{smin} = 150^{\circ}\text{C}$

Note: Non-halide flux should be used.

Regulatory Information

The HCPL-0708 has been approved by the following organizations:

UL

Recognized under UL 1577, component recognition program, File E55361.

CSA

Approved under CSA Component Acceptance Notice #5, File CA88324.

IEC/EN/DINEN60747-5-2

Approved under:
 IEC 60747-5-2:1997 + A1:2002
 EN 60747-5-2:2001 + A1:2002
 DIN EN 60747-5-2 (VDE 0884 Teil 2):2003-01
 (Option 060 only)

Insulation and Safety Related Specifications

Parameter	Symbol	Value	Units	Conditions
Minimum External Air Gap (Clearance)	L(I01)	4.9	mm	Measured from input terminals to output terminals, shortest distance through air.
Minimum External Tracking (Creepage)	L(I02)	4.8	mm	Measured from input terminals to output terminals, shortest distance path along body.
Minimum Internal Plastic Gap (Internal Clearance)		0.08	mm	Insulation thickness between emitter and detector; also known as distance through insulation.
Tracking Resistance (Comparative Tracking Index)	CTI	≥175	Volts	DIN IEC 112/VDE 0303 Part 1
Isolation Group		IIIa		Material Group (DIN VDE 0110, 1/89, Table 1)

All Avago data sheets report the creepage and clearance inherent to the optocoupler component itself. These dimensions are needed as a starting point for the equipment designer when determining the circuit insulation requirements. However, once mounted on a printed circuit

board, minimum creepage and clearance requirements must be met as specified for individual equipment standards. For creepage, the shortest distance path along the surface of a printed circuit board between the solder fillets of the input and output leads must be considered.

There are recommended techniques such as grooves and ribs which may be used on a printed circuit board to achieve desired creepage and clearances. Creepage and clearance distances will also change depending on factors such as pollution degree and insulation level.

IEC/EN/DIN EN 60747-5-2 Insulation Related Characteristics (Option 060)

Description	Symbol	HCPL-0708 Option 060	Units
Installation classification per DIN VDE 0110/1.89, Table 1 for rated mains voltage ≤ 150 V rms for rated mains voltage ≤ 300 V rms for rated mains voltage ≤ 450 V rms		I-IV I-III	
Climatic Classification		55/85/21	
Pollution Degree (DIN VDE 0110/1.89)		2	
Maximum Working Insulation Voltage	V_{IORM}	560	V peak
Input to Output Test Voltage, Method bt $V_{IORM} \times 1.875 = V_{PR}$, 100% Production Test with $t_m = 1$ sec, Partial Discharge < 5 pC	V_{PR}	1050	V peak
Input to Output Test Voltage, Method at $V_{IORM} \times 1.5 = V_{PR}$, Type and Sample Test, $t_m = 60$ sec, Partial Discharge < 5 pC	V_{PR}	840	V peak
Highest Allowable Overvoltage† (Transient Overvoltage, $t_{ini} = 10$ sec)	V_{IOTM}	4000	V peak
Safety Limiting Values (Maximum values allowed in the event of a failure, also see Thermal Derating curve, Figure 11.)			
Case Temperature	T_S	150	°C
Input Current	$I_{S,INPUT}$	150	mA
Output Power	$P_{S,OUTPUT}$	600	mW
Insulation Resistance at T_S , $V_{10} = 500$ V	R_{IO}	$\geq 10^9$	Ω

†Refer to the front of the optocoupler section of the *Isolation and Control Component Designer's Catalog*, under Product Safety Regulations section IEC/EN/DIN EN 60747-5-2, for a detailed description.

Note: These optocouplers are suitable for "safe electrical isolation" only within the safety limit data. Maintenance of the safety data shall be ensured by means of protective circuits.

Note: The surface mount classification is Class A in accordance with CECC 00802.

Absolute Maximum Ratings

Parameter	Symbol	Min.	Max.	Units	Figure
Storage Temperature	T_S	-55	125	°C	
Ambient Operating Temperature ^[1]	T_A	-40	+100	°C	
Supply Voltages	V_{DD}	0	6	Volts	
Output Voltage	V_O	-0.5	$V_{DD2} + 0.5$	Volts	
Average Output Current	I_O		2	mA	
Average Forward Input Current	I_F		20	mA	
Lead Solder Temperature		260°C for 10 sec., 1.6 mm below seating plane			
Solder Reflow Temperature Profile		See Solder Reflow Temperature Profile Section			

Recommended Operating Conditions

Parameter	Symbol	Min.	Max.	Units	Figure
Ambient Operating Temperature	T_A	-40	+100	°C	
Supply Voltages	V_{DD}	4.5	5.5	V	
Input Current (ON)	I_F	10	16	mA	1, 2

Electrical Specifications

Over recommended temperature ($T_A = -40^{\circ}\text{C}$ to $+100^{\circ}\text{C}$) and $4.5\text{ V} \leq V_{DD} \leq 5.5\text{ V}$.

All typical specifications are at $T_A = 25^{\circ}\text{C}$, $V_{DD} = +5\text{ V}$.

Parameter	Symbol	Min.	Typ.	Max.	Units	Test Conditions	Fig.	Notes
Input Forward Voltage	V_F	1.3	1.5	1.8	V	$I_F = 12\text{ mA}$	1	
Input Reverse Breakdown Voltage	BV_R	5			V	$I_R = 10\text{ }\mu\text{A}$		
Logic High Output Voltage	V_{OH}	4.0	4.8		V	$I_F = 0, I_O = -20\text{ }\mu\text{A}$		
Logic Low Output Voltage	V_{OL}		0.01	0.1	V	$I_F = 12\text{ mA}, I_O = 20\text{ }\mu\text{A}$		
Input Threshold Current	I_{TH}			8.2	mA	$I_{OL} = 20\text{ }\mu\text{A}$	2	
Logic Low Output Supply Current	I_{DDL}		6.0	14.0	mA	$I_F = 12\text{ mA}$	4	
Logic High Output Supply Current	I_{DDH}		4.5	11.0	mA	$I_F = 0$	3	

Switching Specifications

Over recommended temperature ($T_A = -40^{\circ}\text{C}$ to $+100^{\circ}\text{C}$) and $4.5\text{ V} \leq V_{DD} \leq 5.5\text{ V}$.

All typical specifications are at $T_A = 25^{\circ}\text{C}$, $V_{DD} = +5\text{ V}$.

Parameter	Symbol	Min.	Typ.	Max.	Units	Test Conditions	Fig.	Notes
Propagation Delay Time to Logic Low Output	t_{PHL}	20	35	60	ns	$I_F = 12\text{ mA}, C_L = 15\text{ pF}$ CMOS Signal Levels	5	1
Propagation Delay Time to Logic High Output	t_{PLH}	13	21	60	ns	$I_F = 12\text{ mA}, C_L = 15\text{ pF}$ CMOS Signal Levels	5	1
Pulse Width	PW	100			ns			
Pulse Width Distortion	PWD	0	14	30	ns	$I_F = 12\text{ mA}, C_L = 15\text{ pF}$ CMOS Signal Levels	2	2
Propagation Delay Skew	t_{PSK}			40	ns	$I_F = 12\text{ mA}, C_L = 15\text{ pF}$ CMOS Signal Levels	3	3
Output Rise Time (10 - 90%)	t_R		20		ns	$I_F = 12\text{ mA}, C_L = 15\text{ pF}$ CMOS Signal Levels		
Output Fall Time (90 - 10%)	t_F		25		ns	$I_F = 12\text{ mA}, C_L = 15\text{ pF}$ CMOS Signal Levels		
Common Mode Transient Immunity at Logic High Output	$ CM_H $	10	15		kV/ μs	$V_{CM} = 1000\text{ V}, T_A = 25^{\circ}\text{C},$ $I_F = 0\text{ mA}$	4	4
Common Mode Transient Immunity at Logic Low Output	$ CM_L $	10	15		kV/ μs	$V_{CM} = 1000\text{ V}, T_A = 25^{\circ}\text{C},$ $I_F = 12\text{ mA}$	5	5

Package Characteristics

All Typicals at $T_A = 25^\circ\text{C}$.

Parameter	Symbol	Min.	Typ.	Max.	Units	Test Conditions
Input-Output Insulation	I_{I-O}			1	μA	45% RH, $t = 5\text{ s}$ $V_{I-O} = 3\text{ kV dc}$, $T_A = 25^\circ\text{C}$
Input-Output Momentary Withstand Voltage	V_{ISO}	3750			Vrms	RH $\leq 50\%$, $t = 1\text{ min.}$, $T_A = 25^\circ\text{C}$
Input-Output Resistance	R_{I-O}		10^{12}		Ω	$V_{I-O} = 500\text{ V dc}$
Input-Output Capacitance	C_{I-O}		0.6		pF	$f = 1\text{ MHz}$, $T_A = 25^\circ\text{C}$

Notes:

- t_{PHL} propagation delay is measured from the 50% level on the rising edge of the input pulse to the 2.5 V level of the falling edge of the V_O signal. t_{PLH} propagation delay is measured from the 50% level on the falling edge of the input pulse to the 2.5 V level of the rising edge of the V_O signal.
- PWD is defined as $|t_{PHL} - t_{PLH}|$.
- t_{PSK} is equal to the magnitude of the worst case difference in t_{PHL} and/or t_{PLH} that will be seen between units at any given temperature within the recommended operating conditions.
- CM_H is the maximum tolerable rate of rise of the common mode voltage to assure that the output will remain in a high logic state.
- CM_L is the maximum tolerable rate of fall of the common mode voltage to assure that the output will remain in a low logic state.

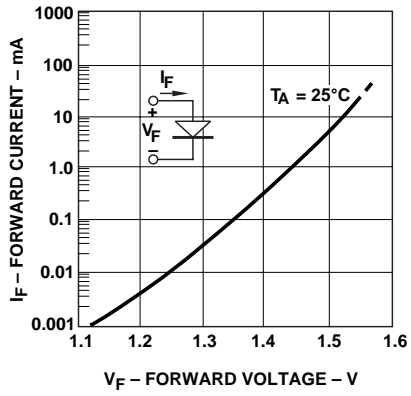

Figure 1. Typical input diode forward characteristic.

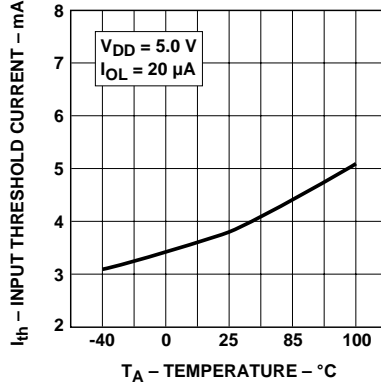

Figure 2. Typical input threshold current vs. temperature.

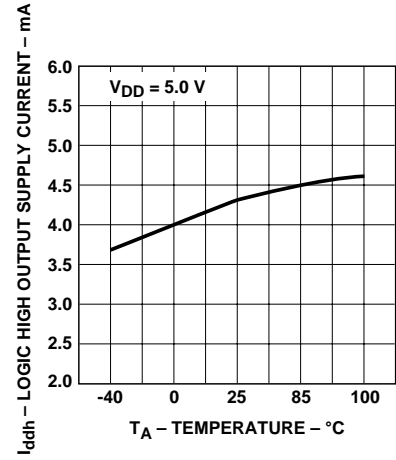

Figure 3. Typical logic high O/P supply current vs. temperature.

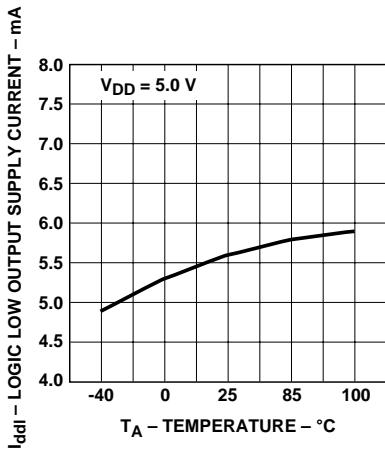

Figure 4. Typical logic low O/P supply current vs. temperature.

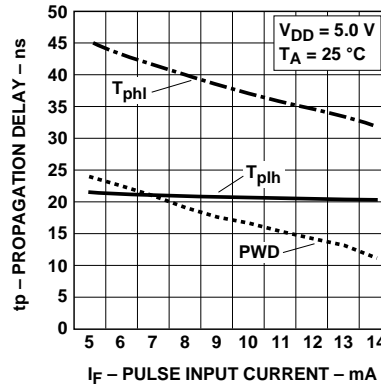

Figure 5. Typical switching speed vs. pulse input current.

Application Information

Bypassing and PC Board Layout

The HCPL-0708 optocoupler is extremely easy to use. No external interface circuitry is required because the HCPL-0708 uses high-speed CMOS IC technology allowing CMOS logic

to be connected directly to the inputs and outputs.

As shown in Figure 6, the only external component required for proper operation is the bypass capacitor. Capacitor values should be between 0.01 μF and

0.1 μF . For each capacitor, the total lead length between both ends of the capacitor and the power-supply pins should not exceed 20 mm. Figure 7 illustrates the recommended printed circuit board layout for the HCPL-0708.

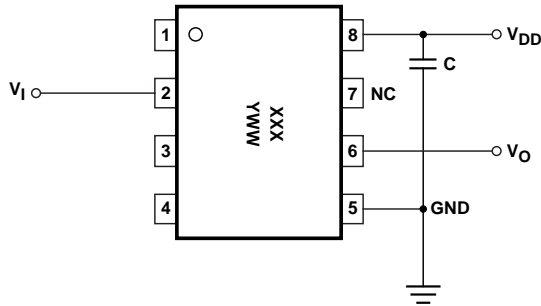

C1, C2 = 0.01 μF TO 0.1 μF

Figure 6. Recommended printed circuit board layout.

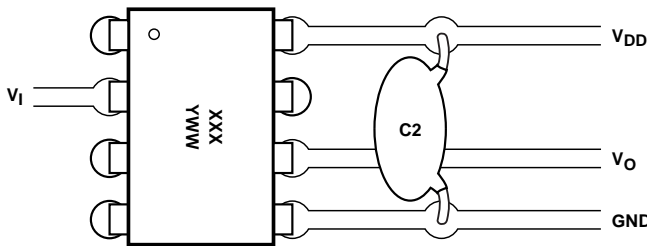

C1, C2 = 0.01 μF TO 0.1 μF

Figure 7. Recommended printed circuit board layout.

Propagation Delay, Pulse-Width Distortion and Propagation Delay Skew

Propagation Delay is a figure of merit which describes how quickly a logic signal propagates through a system. The propaga-

tion delay from low to high (t_{PLH}) is the amount of time required for an input signal to propagate to the output, causing the output to change from low to high. Similarly, the propagation delay from high to low (t_{PHL}) is the

amount of time required for the input signal to propagate to the output, causing the output to change from high to low. See Figure 8.

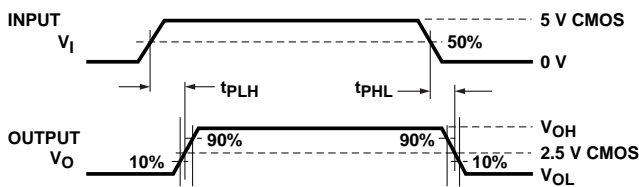

Figure 8.

Pulse-width distortion (PWD) is the difference between t_{PHL} and t_{PLH} and often determines the maximum data rate capability of a transmission system. PWD can be expressed in percent by dividing the PWD (in ns) by the minimum pulse width (in ns) being transmitted. Typically, PWD on the order of 20 - 30% of the minimum pulse width is tolerable; the exact figure depends on the particular application.

Propagation delay skew, t_{PSK} , is an important parameter to consider in parallel data applications where synchronization of signals on parallel data lines is a concern. If the parallel data is

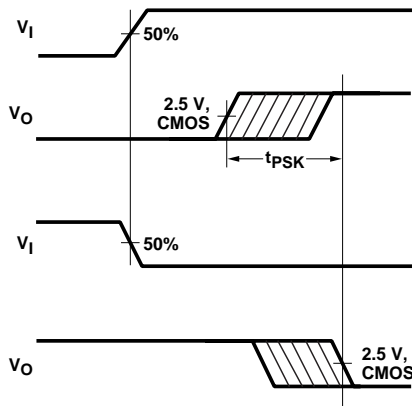

Figure 9. Propagation delay skew waveform.

Propagation delay skew represents the uncertainty of where an edge might be after being sent through an optocoupler. Figure 10 shows that there will be uncertainty in both the data and clock lines. It is important that these two areas of uncertainty not overlap, otherwise the clock signal might arrive before all of the data outputs have settled, or some of the data outputs may

being sent through a group of optocouplers, differences in propagation delays will cause the data to arrive at the outputs of the optocouplers at different times. If this difference in propagation delay is large enough it will determine the maximum rate at which parallel data can be sent through the optocouplers.

Propagation delay skew is defined as the difference between the minimum and maximum propagation delays, either t_{PLH} or t_{PHL} , for any given group of optocouplers which are operating under the same conditions (i.e., the same drive current, supply voltage, output load, and operating temperature). As illustrated in

start to change before the clock signal has arrived. From these considerations, the absolute minimum pulse width that can be sent through optocouplers in a parallel application is twice t_{PSK} . A cautious design should use a slightly longer pulse width to ensure that any additional uncertainty in the rest of the circuit does not cause a problem.

Figure 9, if the inputs of a group of optocouplers are switched either ON or OFF at the same time, t_{PSK} is the difference between the shortest propagation delay, either t_{PLH} or t_{PHL} , and the longest propagation delay, either t_{PLH} or t_{PHL} .

As mentioned earlier, t_{PSK} can determine the maximum parallel data transmission rate. Figure 10 is the timing diagram of a typical parallel data application with both the clock and data lines being sent through the optocouplers. The figure shows data and clock signals at the inputs and outputs of the optocouplers. In this case the data is assumed to be clocked off of the rising edge of the clock.

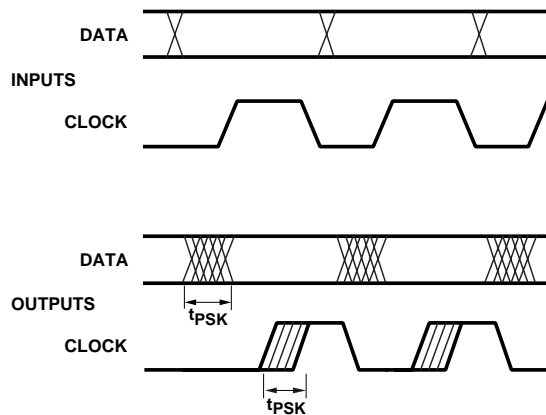

Figure 10. Parallel data transmission example.

The HCPL-0708 optocouplers offer the advantage of guaranteed specifications for propagation delays, pulse-width distortion, and propagation delay skew over the recommended temperature and power supply ranges.

For product information and a complete list of distributors, please go to our website: www.avagotech.com

Avago, Avago Technologies, and the A logo are trademarks of Avago Technologies Limited in the United States and other countries.
Data subject to change. Copyright © 2007 Avago Technologies Limited. All rights reserved. Obsoletes AV01-0031EN
AV01-0582EN July 7, 2007

