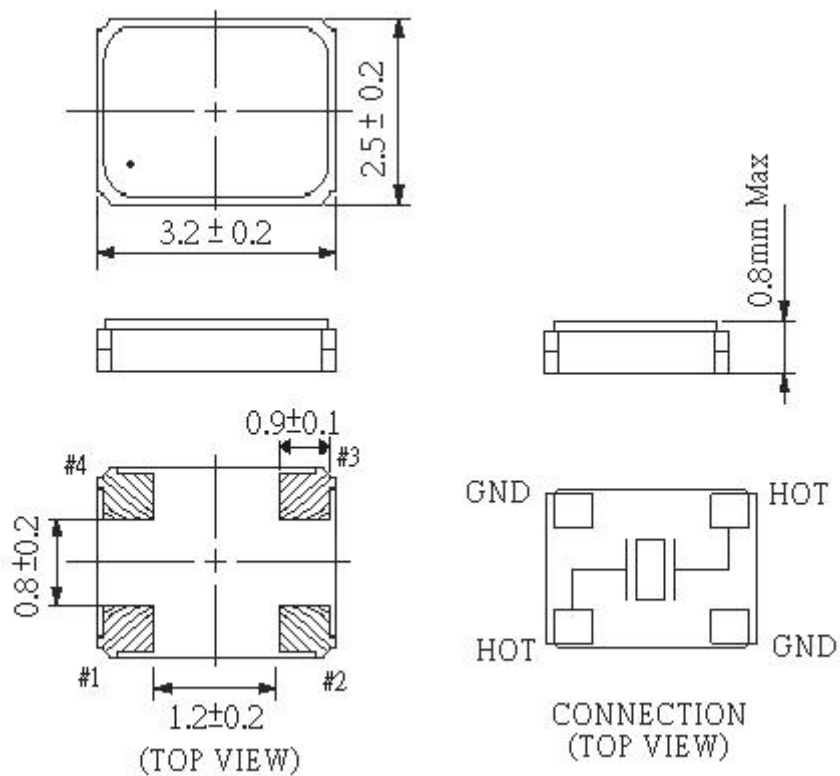
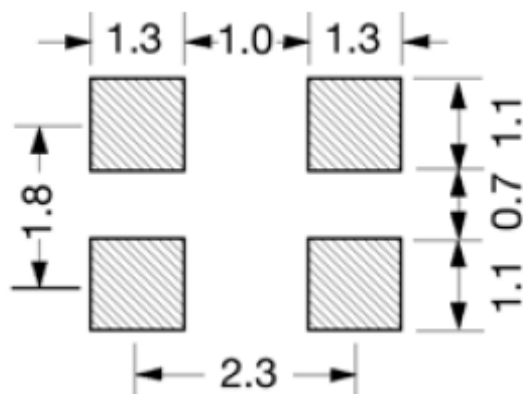

1. QUARTZ CRYSTAL UNIT SPECIFICATION

Item	Symbol	Specifications				Remark
		Min	Type	Max	Units	
1. Production type		SMD Quartz Crystal Resonator				
2. Holder		SMD 3.2x2.5				Seam Seal
3. Mode of oscillation		<input checked="" type="checkbox"/> Fundamental <input type="checkbox"/> 3 Overtone <input type="checkbox"/> 5 Overtone				
4. Frequency	FL	16.000000		MHz		
5. Load capacitance	CL	9		pF		
6. Frequency tolerance	Tol	±10		ppm	at 25°C ± 3°C	
7. Equivalent resistance	Rs	80		Ω	Max.	
8. Working temperature range	TR	-10 ~ 60		°C		
9. Freq. Temp. Characteristics	TC	± 30		ppm	working temperature ΔF	
10. Drive level	DL	100		μW		
11. Shunt Capacitance	C0	5		pF		
12. Storage temperature range		-40 ~ 85		°C		
13. Insulation resistance		500		MΩ	Min.	
14. Measure Circuit		S&A 250B				π network
15. Aging		5		ppm/Yr	Max.	

※ **This product doesn't include harmful substance that stipulated by RoHS**

2. MARKING & DIMENSIONS
2.1 DIMENSIONS (Unit: mm)

2.2 Recommended Land Pattern (Unit: mm)

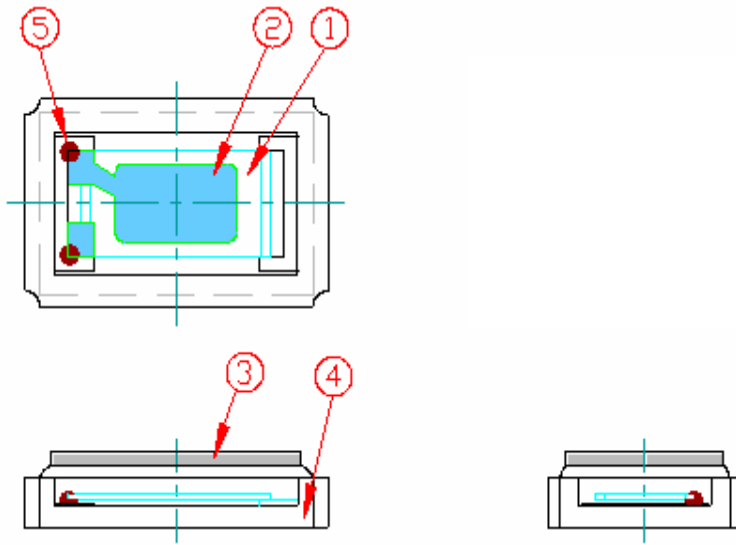
2.3 INSIDE STRUCTURE

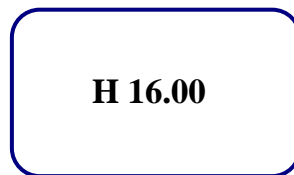

DESCRIPTION	
1	Quartz Blank
2	Electrode
3	Lid
4	Base
5	Conductive adhesive

2.4 MARKING



3. CHARACTERISTICS

Units and values indicated with { } in this specification are the former units and the specified values.

Standard atmospheric conditions:

Unless otherwise specified, the standard range of atmospheric conditions for making measurements and tests is as follows:

Ambient temperature: 15°C to 35°C

Relative humidity : 25% to 85%

Air pressure : 86 to 106 kPa

If there is any doubt about the results, measurements shall be made within the following limits:

Ambient temperature : 25°C±1°C

Relative humidity : 63% to 67%

Air pressure : 86 to 106 kPa

Operating temperature range:

The operating temperature range is the range of ambient temperatures at which the quartz crystal oscillator can be stored without damage. Conditions are as specified elsewhere on these specifications.

Operating temperature range: -10°C to +60°C

Storage temperature range:

The storage temperature range is the range of ambient temperatures at which the quartz crystal oscillator can be stored without damage. Conditions are as specified elsewhere on these specifications.

Storage temperature range: -40°C to +85°C

3.1 Mechanical characteristics

Provided that measurement shall be carried out after letting it alone in the room temperature for 1h.

Item		Specifications	
1	Drop Test	Dropping 3 times from the height of 75cm onto hard wooden board of thickness more than 30mm.	
2	Mechanical Shock	Devices are shocked to half sine wave (1000 G) three mutually perpendicular axes each 3 times.	
3	Vibration	(1) Vibration Frequency	10~55Hz
		(2) Cycle	1 to 2 min
		(3) Amplitude	1.0mm
		(4) Direction	X.Y.Z
		(5) Time	2hr for each direction
4	Solderability	MIL - STD - 20E Method 208C	
		Temperature	245°C±5°C
		Material	H63A (Silver 2 ~ 3 %)
		Immersion depth	0.5 mm minimum
		Immersion time	3 ± 0.5 seconds
	Flux	Rosin resin methyl alcohol solvent (1 : 4)	
5	Resistance to Soldering Heat	MIL - SLD -202, Method 210, Condition I or J 10 sec immersion into 260 ± 5°C solder pot, above 180°C is 90 ~ 120 sec.	

*Frequency variation shall be within +/-5ppm and equivalent resistance less than ±15% max. after the test.

Note: Measuring the frequency should be done after keeping test samples at room temperature for 24 hours.

3.2 Environmental characteristics

Provided that measurement shall be carried out after letting it alone in the room temperature for 1h.

Item		Specifications
1	Humidity	It alone at $40^{\circ}\text{C} \pm 2^{\circ}\text{C}$ in humidity of 90~95% for 48h.
2	Storage in Low Temperature	It alone at $-40^{\circ}\text{C} \pm 2^{\circ}\text{C}$ for 240h.
3	Storage in High Temperature	It alone at $85^{\circ}\text{C} \pm 2^{\circ}\text{C}$ for 240h.
4	Temperature Cycle	The following temperature cycle (10 cycles). Refer to below Fig. Temperature shift from low to high, high to low shall be done in $1^{\circ}\text{C}/\text{min}$.

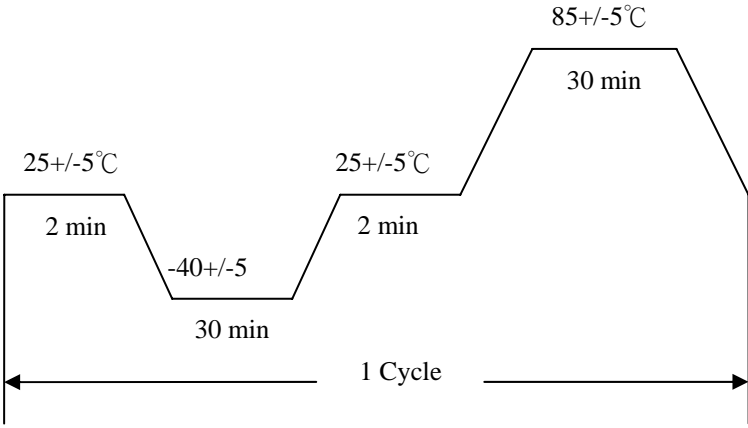

The graph illustrates a temperature cycle with four stages: a 2-minute hold at $25 \pm 5^{\circ}\text{C}$, a 30-minute hold at $-40 \pm 5^{\circ}\text{C}$, another 2-minute hold at $25 \pm 5^{\circ}\text{C}$, and a final 30-minute hold at $85 \pm 5^{\circ}\text{C}$. The temperature transitions between these stages occur at a rate of $1^{\circ}\text{C}/\text{min}$. A horizontal arrow below the graph indicates that this sequence constitutes one cycle, and the entire test consists of 10 such cycles.

*Frequency variation shall be within $\pm 5\text{ppm}$ and equivalent resistance less than $\pm 15\%$ max. after the test.

Note: Measuring the frequency should be done after keeping test samples at room temperature for 24 hours.

3.3 SUGGESTED IR REFLOW PROFILE

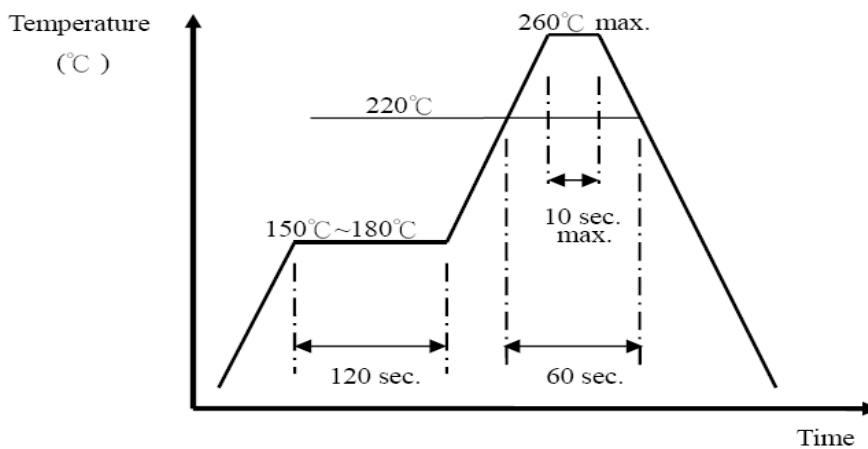

4. PACKING

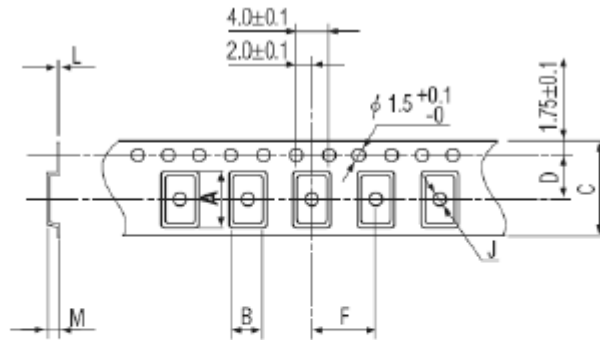

A	B	C	D	F	J	L	M	Reel Dia.	Qty/Reel
3.5	2.8	8.0	3.5	4.0	1.1	0.25	1.0	180	1000

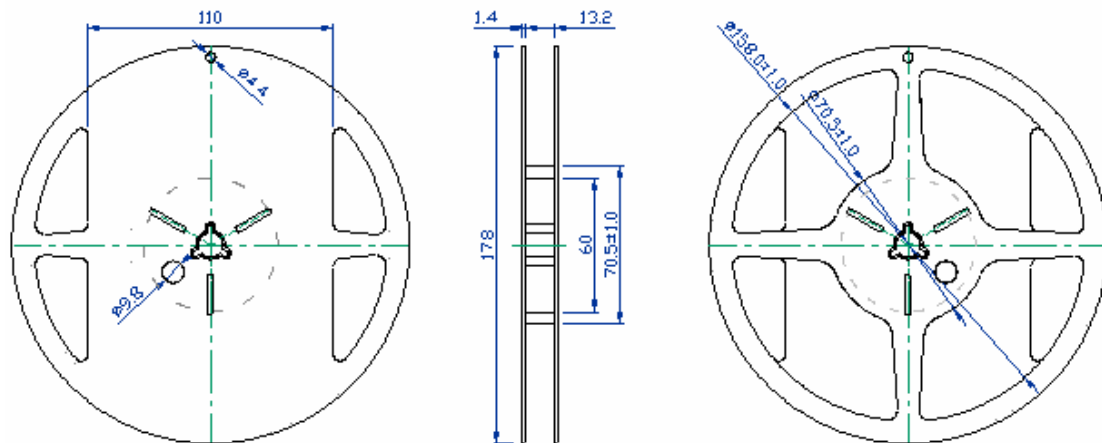

1. 230mm minimum leader which consist of carrier and tape followed by a minimum of 160mm of empty carrier tape sealed with cover tape.
2. 160mm minimum trailer of empty carrier tape sealed with cover tape.

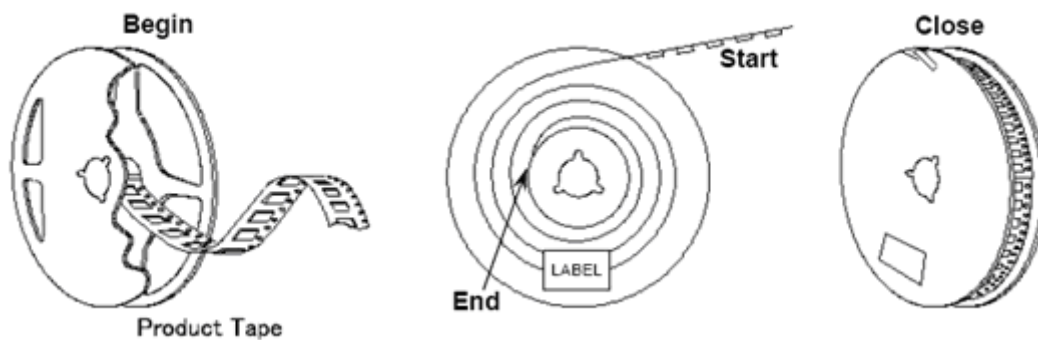

5. Note

1. Only the lead should be heated when soldering.

In case that the package temperature is exceeding 150°C , it may impair the crystal or may cause the crystal quartz to destroy.

2. Pulling the lead strongly may cause cracking of the hermetic glass seal bending the lead closely from the case may also cause same problem, so when the lead needs to be bent, please leave more than 0.5mm of lead from the case.
3. Too much shock or vibration is not allowed. According to conditions such as machine shock during the assembly, the internal quartz crystal might be damaged.

Please check your conditions carefully when using it in advance.

4. Don't storage or use in the environment that temperature may change rapidly to avoid the condensation. And also we recommend to storage the products in the normal environment. (Temperature, humidity)
5. This product can be subjected to ultrasonic cleaning. However, since the oscillator may be affected depending on the condition, be sure to check it.
6. Applying excessive drive level to the quartz crystal may cause deterioration for characteristics or damage.

Circuit design must be such as to maintain a proper drive level.

7. Unless adequate negative resistance is allocated in the oscillation circuit, startup time of oscillation may be increased or no oscillation may occur. In order to avoid this, provide enough negative resistance in the circuitry design.