

# HD14527B

## BCD Rate Multiplier

The HD14527B BCD rate multiplier(DRM) provides an output pulse rate based upon the BCD input number. For example, if 6 is the BCD input number, there will be six output pulses for every ten input pulses. This part may be used for arithmetic operations including multiplication and division. Typical applications include digital filters, motor speed control and frequency synthesizers.

### FEATURES

- Quiescent Current=5nA/pkg typ. @5V
- Supply Voltage Range=3 to 18V
- Low Input Capacitance= 5pF typ.
- Internally Synchronous for High Speed
- Output Clocked on the Negative Going Edge of Clock
- Strobe for Inhibiting or Enabling Outputs
- Enable and Cascade Inputs for Cascade Operation of Two or More DRMs
- " 9 " Output for the Parallel Enable Configuration and DRMs in Cascade
- Complementary Outputs
- Clear and Set to Nine Inputs

### PIN ARRANGEMENT

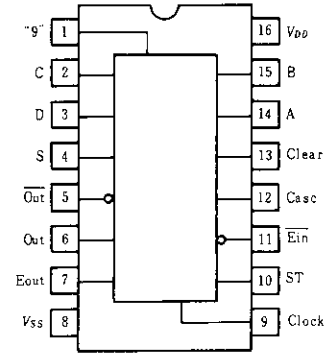

(Top View)

### TRUTH TABLE

Inputs										Output			
										Logic Level			
										Number of Pulses			
D	C	B	A	Number of Clock Pulses	Ein	Strobe	Cascade	Clear	Set	Out	Out	Eout	" 9 "
0	0	0	0	10	0	0	0	0	0	0	1	1	1
0	0	0	1	10	0	0	0	0	0	1	1	1	1
0	0	1	0	10	0	0	0	0	0	2	2	1	1
0	0	1	1	10	0	0	0	0	0	3	3	1	1
0	1	0	0	10	0	0	0	0	0	4	4	1	1
0	1	0	1	10	0	0	0	0	0	5	5	1	1
0	1	1	0	10	0	0	0	0	0	6	6	1	1
0	1	1	1	10	0	0	0	0	0	7	7	1	1
1	0	0	0	10	0	0	0	0	0	8	8	1	1
1	0	0	1	10	0	0	0	0	0	9	9	1	1
1	0	1	0	10	0	0	0	0	0	8	8	1	1
1	0	1	1	10	0	0	0	0	0	9	9	1	1
1	1	0	0	10	0	0	0	0	0	8	8	1	1
1	1	0	1	10	0	0	0	0	0	9	9	1	1
1	1	1	0	10	0	0	0	0	0	8	8	1	1
1	1	1	1	10	0	0	0	0	0	9	9	1	1
x	x	x	x	10	1	0	0	0	0	--	--	--	--
x	x	x	x	10	0	1	0	0	0	0	1	1	1
x	x	x	x	10	0	0	1	0	0	1	0	1	1
1	x	x	x	10	0	0	0	1	0	10	10	1	0
0	x	x	x	10	0	0	0	1	0	0	1	1	0
x	x	x	x	10	0	0	0	0	1	0	1	0	1

x=Don't Care

LOGIC DIAGRAM

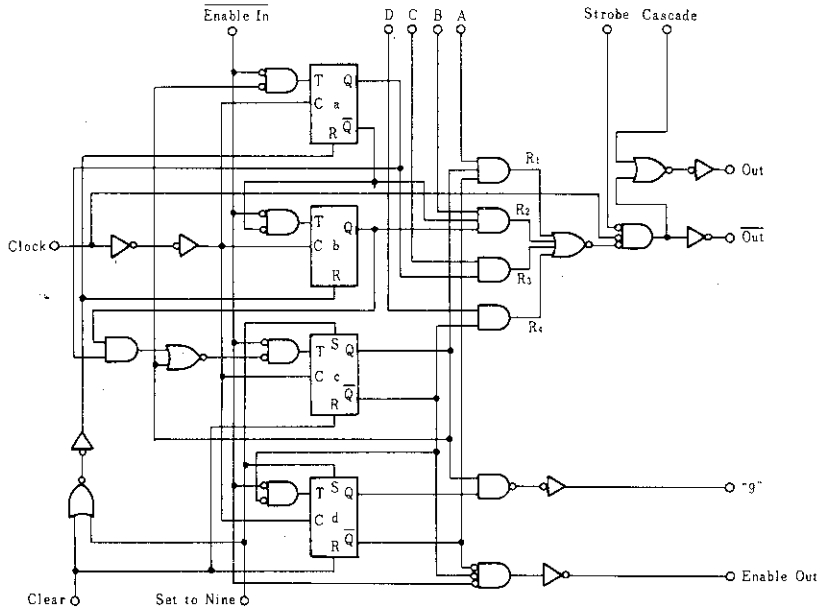

ELECTRICAL CHARACTERISTICS

Characteristic	Symbol	V <sub>DD</sub> (V)	Test Conditions	-40°C		25°C			85°C		Unit
				min	max	min	typ	max	min	max	
Output Voltage	V <sub>OL</sub>	5.0	V <sub>in</sub> =V <sub>DD</sub> or 0	—	0.05	—	0	0.05	—	0.05	V
		10		—	0.05	—	0	0.05	—	0.05	
		15		—	0.05	—	0	0.05	—	0.05	
	V <sub>OH</sub>	5.0	V <sub>in</sub> =0 or V <sub>DD</sub>	4.95	—	4.95	5.0	—	4.95	—	V
		10		9.95	—	9.95	10	—	9.95	—	
		15		14.95	—	14.95	15	—	14.95	—	
Input Voltage	V <sub>IL</sub>	5.0	V <sub>out</sub> =4.5 or 0.5V	—	1.5	—	2.25	1.5	—	1.5	V
		10	V <sub>out</sub> =9.0 or 1.0V	—	3.0	—	4.50	3.0	—	3.0	
		15	V <sub>out</sub> =13.5 or 1.5V	—	4.0	—	6.75	4.0	—	4.0	
	V <sub>IH</sub>	5.0	V <sub>out</sub> =0.5 or 4.5V	3.5	—	3.5	2.75	—	3.5	—	V
		10	V <sub>out</sub> =1.0 or 9.0V	7.0	—	7.0	5.50	—	7.0	—	
		15	V <sub>out</sub> =1.5 or 13.5V	11.0	—	11.0	8.25	—	11.0	—	
Output Drive Current	I <sub>OH</sub>	5.0	V <sub>OH</sub> =2.5V	-1.0	—	-0.8	-1.7	—	-0.6	—	mA
		5.0	V <sub>OH</sub> =4.6V	-0.2	—	-0.16	-0.36	—	-0.12	—	
		10	V <sub>OH</sub> =9.5V	-0.5	—	-0.4	-0.9	—	-0.3	—	
		15	V <sub>OH</sub> =13.5V	-1.4	—	-1.2	-3.5	—	-1.0	—	
	I <sub>OL</sub>	5.0	V <sub>OL</sub> =0.4V	0.52	—	0.44	0.88	—	0.36	—	mA
		10	V <sub>OL</sub> =0.5V	1.3	—	1.1	2.25	—	0.9	—	
15		V <sub>OL</sub> =1.5V	3.6	—	3.0	8.8	—	2.4	—		
Input Current	I <sub>in</sub>	15		—	±0.3	—	±0.0001	±0.3	—	±1.0	μA
Input Capacitance	C <sub>in</sub>	—	V <sub>in</sub> =0	—	—	—	5.0	7.5	—	—	pF
Quiescent Current	I <sub>DD</sub>	5.0	Zero Signal, per Package	—	20	—	0.005	20	—	150	μA
		10		—	40	—	0.010	40	—	300	
		15		—	80	—	0.015	80	—	600	
Total Supply Current*	I <sub>T</sub>	5.0	Dynamic+I <sub>DD</sub> ,	—	—	—	0.85	—	—	—	μA
		10	per Gate	—	—	—	1.75	—	—	—	
		15	C <sub>L</sub> =50 pF, f=1 kHz	—	—	—	2.6	—	—	—	

\* To calculate total supply current at frequency other than 1kHz.

@V<sub>DD</sub>=5.0V I<sub>T</sub>=(0.85μA/kHz)f+I<sub>DD</sub>. @V<sub>DD</sub>=10V I<sub>T</sub>=(1.75μA/kHz)f+I<sub>DD</sub>. @V<sub>DD</sub>=15V I<sub>T</sub>=(2.6μA/kHz)f+I<sub>DD</sub>

● POWER DISSIPATION TEST CIRCUIT AND WAVEFORM

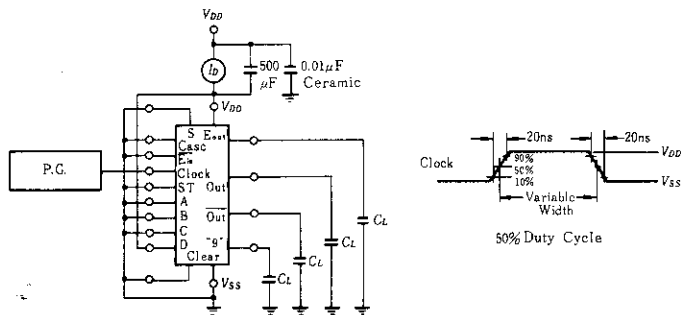

■ SWITCHING CHARACTERISTICS ( $C_L=50\text{pF}$ ,  $T_a=25^\circ\text{C}$ )

Characteristic		Symbol	$V_{DD}$ (V)	min	typ	max	Unit
Output Rise Time		$t_r$	5.0	—	180	400	ns
			10	—	90	200	
			15	—	65	160	
Output Fall Time		$t_f$	5.0	—	100	200	ns
			10	—	50	100	
			15	—	37	80	
Propagation Delay Time	Clock to Out	$t_{PHL}$	5.0	—	200	500	ns
			10	—	100	250	
			15	—	70	175	
	Clock to $\overline{\text{Out}}$	$t_{PLH}$	5.0	—	125	315	
			10	—	65	150	
			15	—	45	115	
	Clock to Eout	$t_{PHL}$	5.0	—	295	900	
			10	—	130	325	
			15	—	85	230	
	Clock to "g"	$t_{PHL}$	5.0	—	400	1000	
			10	—	155	400	
			15	—	110	300	
Set, Clear to Out	$t_{PHL}$	5.0	—	380	1000	ns	
		10	—	165	400		
		15	—	110	300		
Cascade to Out	$t_{PLH}$	5.0	—	125	315	ns	
		10	—	65	150		
		15	—	45	115		
Strobe to Out	$t_{PLH}$	5.0	—	230	700	ns	
		10	—	105	265		
		15	—	70	190		
Clock Pulse Width	$PW_C$	5.0	500	250	—	ns	
		10	200	110	—		
		15	150	80	—		
Clock Frequency	$PRF$	5.0	—	2.0	1.0	MHz	
		10	—	4.5	2.5		
		15	—	6.0	3.3		
Clock Pulse Rise and Fall Time	$t_r, t_f$	5.0	—	—	15	$\mu\text{s}$	
		10	—	—	15		
		15	—	—	15		
Set or Clear Pulse Width	$PW_S$ $PW_{clear}$	5.0	240	80	—	ns	
		10	100	35	—		
		15	75	30	—		
Set Removal Time	$t_{rem}$	5.0	0	-20	—	ns	
		10	0	-10	—		
		15	0	-7.5	—		
Enable In Setup Time	$t_{setup}$	5.0	400	175	—	ns	
		10	150	60	—		
		15	120	45	—		

■ TIMING DIAGRAM

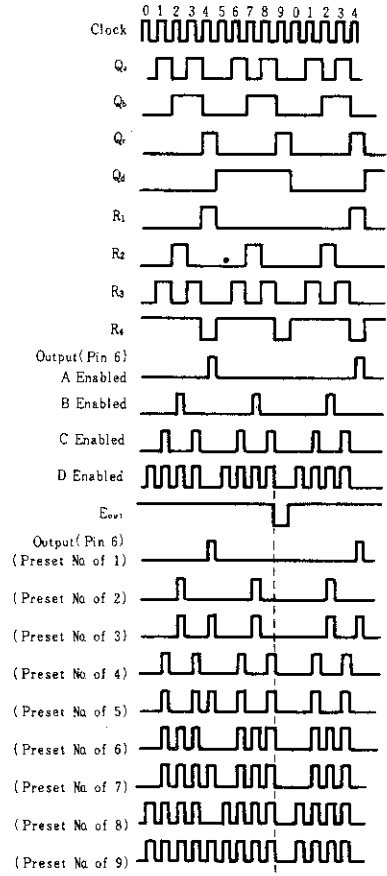
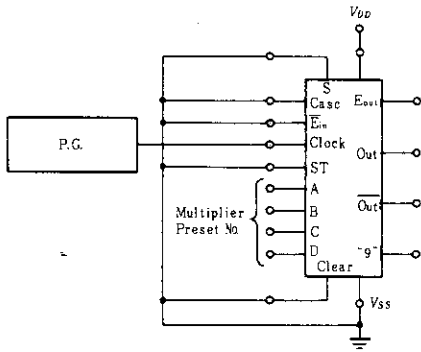

■ SWITCHING TIME TEST CIRCUIT

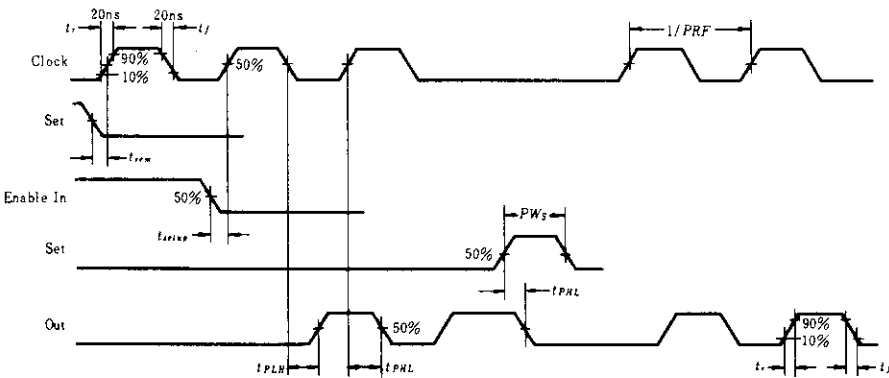
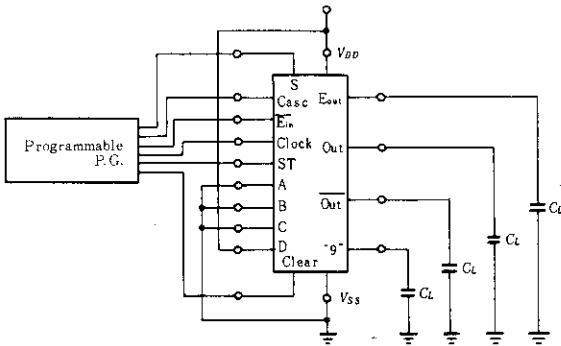

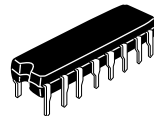
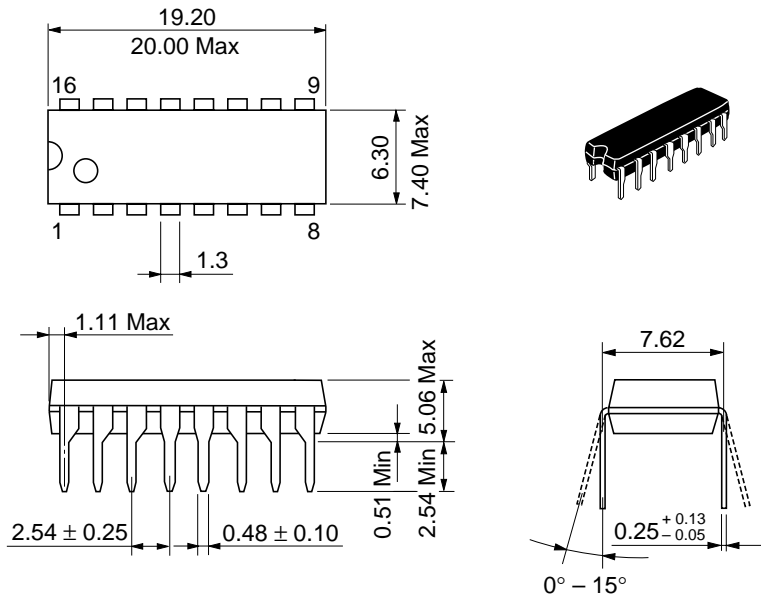

Hitachi Code	DP-16
JEDEC	Conforms
EIAJ	Conforms
Weight (reference value)	1.07 g

## Cautions

1. Hitachi neither warrants nor grants licenses of any rights of Hitachi's or any third party's patent, copyright, trademark, or other intellectual property rights for information contained in this document. Hitachi bears no responsibility for problems that may arise with third party's rights, including intellectual property rights, in connection with use of the information contained in this document.
2. Products and product specifications may be subject to change without notice. Confirm that you have received the latest product standards or specifications before final design, purchase or use.
3. Hitachi makes every attempt to ensure that its products are of high quality and reliability. However, contact Hitachi's sales office before using the product in an application that demands especially high quality and reliability or where its failure or malfunction may directly threaten human life or cause risk of bodily injury, such as aerospace, aeronautics, nuclear power, combustion control, transportation, traffic, safety equipment or medical equipment for life support.
4. Design your application so that the product is used within the ranges guaranteed by Hitachi particularly for maximum rating, operating supply voltage range, heat radiation characteristics, installation conditions and other characteristics. Hitachi bears no responsibility for failure or damage when used beyond the guaranteed ranges. Even within the guaranteed ranges, consider normally foreseeable failure rates or failure modes in semiconductor devices and employ systemic measures such as fail-safes, so that the equipment incorporating Hitachi product does not cause bodily injury, fire or other consequential damage due to operation of the Hitachi product.
5. This product is not designed to be radiation resistant.
6. No one is permitted to reproduce or duplicate, in any form, the whole or part of this document without written approval from Hitachi.
7. Contact Hitachi's sales office for any questions regarding this document or Hitachi semiconductor products.

# HITACHI

## Hitachi, Ltd.

Semiconductor & Integrated Circuits.  
Nippon Bldg., 2-6-2, Ohte-machi, Chiyoda-ku, Tokyo 100-0004, Japan  
Tel: Tokyo (03) 3270-2111 Fax: (03) 3270-5109

URL      North America      : <http://semiconductor.hitachi.com/>  
             Europe                 : <http://www.hitachi-eu.com/hel/ecg>  
             Asia (Singapore)       : <http://www.has.hitachi.com.sg/grp3/sicd/index.htm>  
             Asia (Taiwan)            : [http://www.hitachi.com.tw/E/Product/SICD\\_Frame.htm](http://www.hitachi.com.tw/E/Product/SICD_Frame.htm)  
             Asia (HongKong)       : <http://www.hitachi.com.hk/eng/bo/grp3/index.htm>  
             Japan                        : <http://www.hitachi.co.jp/Sicd/indx.htm>

## For further information write to:

Hitachi Semiconductor  
(America) Inc.  
179 East Tasman Drive,  
San Jose, CA 95134  
Tel: <1> (408) 433-1990  
Fax: <1> (408) 433-0223

Hitachi Europe GmbH  
Electronic components Group  
Dornacher Straße 3  
D-85622 Feldkirchen, Munich  
Germany  
Tel: <49> (89) 9 9180-0  
Fax: <49> (89) 9 29 30 00

Hitachi Europe Ltd.  
Electronic Components Group.  
Whitebrook Park  
Lower Cookham Road  
Maidenhead  
Berkshire SL6 8YA, United Kingdom  
Tel: <44> (1628) 585000  
Fax: <44> (1628) 778322

Hitachi Asia Pte. Ltd.  
16 Collyer Quay #20-00  
Hitachi Tower  
Singapore 049318  
Tel: 535-2100  
Fax: 535-1533

Hitachi Asia Ltd.  
Taipei Branch Office  
3F, Hung Kuo Building, No.167,  
Tun-Hwa North Road, Taipei (105)  
Tel: <886> (2) 2718-3666  
Fax: <886> (2) 2718-8180

Hitachi Asia (Hong Kong) Ltd.  
Group III (Electronic Components)  
7/F., North Tower, World Finance Centre,  
Harbour City, Canton Road, Tsim Sha Tsui,  
Kowloon, Hong Kong  
Tel: <852> (2) 735 9218  
Fax: <852> (2) 730 0281  
Telex: 40815 HITEC HX

Copyright ' Hitachi, Ltd., 1999. All rights reserved. Printed in Japan.

## HITACHI