

HD63485

Description

The HD63485 LSI belongs to the ACRTC (advanced CRT controller) family. It provides memory access control to frame buffers for graphic display and drawing. Incorporating bus driver circuits and a DRAM (dynamic RAM) interface, the GMIC allows direct connection to DRAMs with no external circuits. Its main function includes address data latch, DRAM row and column address multiplexing, supplying RAS, CAS, OE, WE, and other signals, and generating the 2CLK signal for the ACRTC. Using the Hi-BiCMOS process, the HD63485 achieves high speed memory access with low power dissipation.

Type of Products

Part No.	Speed	Package
HD63485PS-32	32MHz	64-pin Plastic Shrink DIP (DP-64S)
HD63485PS-48	48MHz	
HD63485PS-64	64MHz	
HD63485CP-32	32MHz	68-pin PLCC (CP-68)
HD63485CP-48	48MHz	
HD63485CP-64	64MHz	

Features

- Drives frame buffer memory directly ($I_{OL} = 24 \text{ mA max}$)
- Generates DRAM signal: row and column addresses, RAS, CAS, OE, WE, etc
- High-speed dot rate input (64 MHz max)
- Direct ACRTC interface
- Generates horizontal scrolling control signals
- Generates load signals for horizontal smooth scrolling
- Programmable address increment mode
- Generates 2CLK signal
- TTL-compatible input/output
- Single +5 V power supply
- Low power dissipation



Pin Description

Figure 1 shows the pin arrangement for the 64-pin shrink-type DIP and the 68-pin PLCC packages. Pins marked with* are bus drivers, which can

handle a maximum output current I_{OL} of 24mA. Table 1 describes the pins.

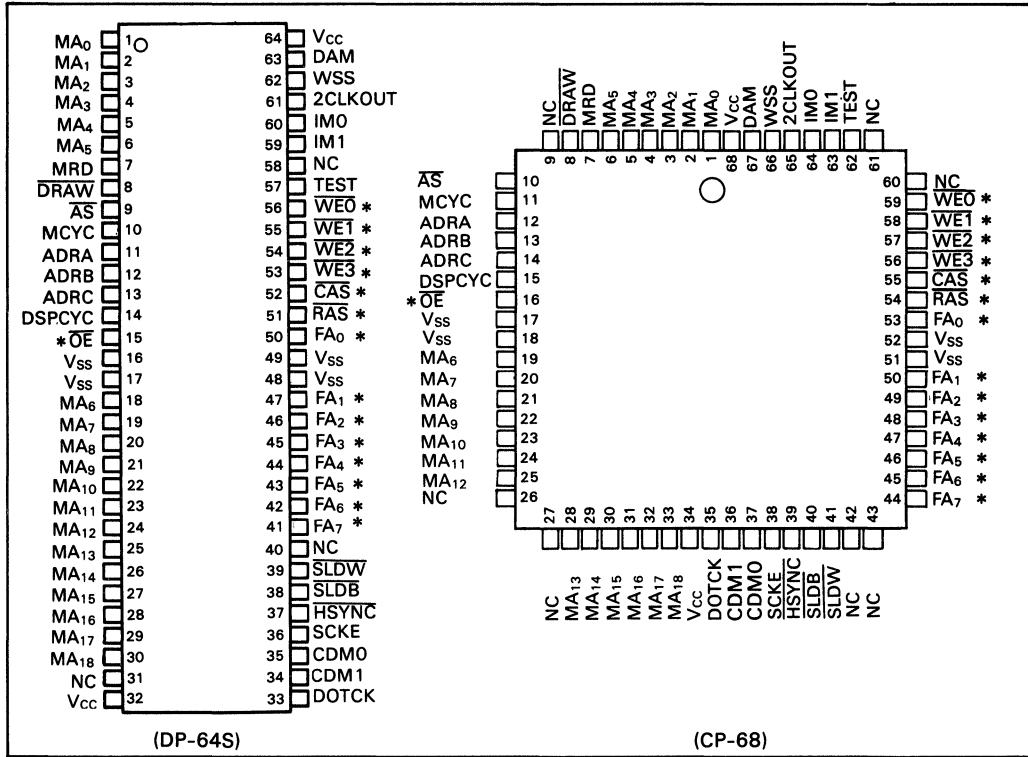

Figure 1. Pin arrangement



Power Supply (V_{SS}, V_{CC})

V_{SS} and V_{CC} are the GMIC power supply pins. V_{CC} pins are +5 V ± 5 % supply pins. V_{SS} are the ground

pins. Be sure to connect all four V_{SS} pins to ground and both V_{CC} pins to the power supply.

Table 1. Pin Description

Signal	Pin Number		I/O	Description
	DIP-64	PLCC-68		
V _{CC}	32,64	34,68		+ 5 V power supply
V _{SS}	16,17, 17,18, 48,49	51,52		Ground
CDM1, CDM0	34,35	36,37	I	Clock division ratio
DAM	63	67	I	Dual access mode
IM1, IMO	59,60	63,64	I	Increment mode
WSS	62	66	I	Window smooth scroll
DOTCK	33	35	I	Dot clock
TEST	57	62	I	Test
2CLKOUT	61	65	O	Clock
MCYC	10	11	I	Memory cycle
$\overline{\text{DRAW}}$	8	8	I	Draw
MRD	7	7	I	Memory read
$\overline{\text{AS}}$	9	10	I	Address strobe
MA18- MA0	30-18, 33-28, 6-1	25-19, 6-1	I	Memory address bus
$\overline{\text{HSYNC}}$	37	39	I	Horizontal sync
$\overline{\text{RAS}}$	51	54	O	Row address strobe
$\overline{\text{CAS}}$	52	55	O	Column address strobe
$\overline{\text{WE}}$ -3- $\overline{\text{WE}}$ 0	53-56	56-59	O	Write enable
$\overline{\text{OE}}$	15	16	O	Output enable
FA7-FA0	41-47, 44-50, 50	53	O	Frame buffer address
ADRA- ADRC	11-13	12-14	O	Address
SCKE	36	38	O	Shift clock enable
$\overline{\text{SLDB}}$, SLDW	38, 39	40, 41	O	Shift load signals

Program Pins

Clock Division Ratio (CDM1, CDM0): The CDM1 and CDM0 inputs determine the division ratio used to generate 2CLKOUT for the ACRTC from the DOTCK input. See Table 2.

Dual Access Mode (DAM): The DAM input sets the access mode as shown in Table 3.

Increment Mode (IM 1, IM 0): The IM 1 and IM 0 inputs determine the addresses sent from memory addresses (MA 18-MA 0) as the frame buffer output (FA 7-FA 0) to accommodate different DRAM types. Table 4 shows the memory address outputs corresponding to the IM 1 and IM 0 settings. Note that the frame buffer addresses (FA 7-FA 0) have multiplexed memory address outputs.

IM inputs are closely related to the graphic address increment (GAI) of the ACRTC (see ACRTC User's Manual).

Window Smooth Scroll (WSS): When the WSS input is low (0), each base screen can be scrolled in single access mode, dual access mode 0, and dual access mode 1. The SLDW signal contains the

scrolling data.

When the WSS input is high (1), the window screen can be smooth scrolled in dual access mode 1. The SLDW signal contains the scrolling data.

Operation Control Signals

Dot Clock (DOTCK): The DOTCK input must be the same clock that is supplied to the shift register for video signal generation. Dot clock frequency is determined by the horizontal display resolution (pixel count) and the display period of one horizontal scan.

Test (TEST): The TEST input is used for manufacturing operational testing. It must be fixed low when the GMIC is mounted in a system.

ACRTC Interface Signals

Clock (2CLK): The 2CLKOUT clock output is a basic clock for the ACRTC's internal operation. The GMIC generates 2CLKOUT by dividing the high-speed dot clock by the ratio determined by the CDM 1 and CDM 0 inputs.

Table 2. Clock Division Ratio

CDM 1	CDM 0	Division Ratio
0	0	Not allowed
0	1	Divide by 4
1	0	Divide by 8
1	1	Divide by 16

Table 3. Access Modes

DAM	Access Mode
0	Single access mode
1	Dual access mode

Table 4. Increment Mode

IM 1	IM 0	Increment Mode	Address Output to FA 7-FA 0	Address Output to ADRC-ADRA
0	0	+1	MA ₁₅ -MA ₈ , MA ₇ -MA ₀	MA ₁₈ , MA ₁₇ , MA ₁₆
0	1	+2	MA ₁₆ -MA ₉ , MA ₈ -MA ₁	MA ₀ , MA ₁₇ , MA ₁₈
1	0	+4	MA ₁₇ -MA ₁₀ , MA ₉ -MA ₂	MA ₀ , MA ₁ , MA ₁₈
1	1	+8	MA ₁₈ -MA ₁₁ , MA ₁₀ -MA ₃	MA ₀ , MA ₁ , MA ₂



Memory Cycle (MCYC): The MCYC input indicates the ACRTC's frame buffer access timing. MCYC is low when the ACRTC is in the address cycle, and high when the ACRTC is in the data cycle.

Draw (DRAW): The DRAW input indicates whether the ACRTC memory cycle is a drawing cycle. DRAW is low during drawing cycle, and high otherwise. The GMIC uses DRAW to recognize display cycles, and also to generate DRAM control signals (WE 3-WE 0).

Memory Read (MRD): The MRD input controls data transfer between frame buffers and the ACRTC. The ACRTC pulls MRD high when it reads data from the frame buffer, and low when it writes data.

The only exception is when the ACRTC is in superimpose display mode (dual access mode 1). In superimpose display mode, the ACRTC inputs a low level and reads data from a frame buffer in order to indicate that the display cycle is for a superimposed screen (window screen).

Address Strobe (AS): The AS input is a latch timing signal for the memory address sent from the ACRTC. Additionally, AS indicates whether memory is begin accessed. For example, for horizontal zooming, the SLDB signal is provided at a lower frequency, corresponding to the lower frequency of AS.

Memory Address Bus (MA₁₈-MA₀): The MA₁₈-MA₀ inputs are address signals for frame buffer access, provided by the ACRTC.

Horizontal Sync (HSYNC): The HSYNC input is a DRAM refresh cycle control signal to horizontally synchronize CRT displays. The GMIC performs RAS only refresh when HSYNC is low and DRAW is high when AS pulses are input.

Setting HSYNC low informs the GMIC of the end of a raster display. Usually, the ACRTC's HSYNC output supplies this input.

Frame Buffer Access Signals

Row Address Strobe (RAS): The GMIC outputs the DRAMs' RAS timing signal on the RAS output.

Column Address Strobe (CAS): The GMIC outputs the DRAMs' CAS timing signal on the CAS output.

Write Enable (WE 3-WE 0): The GMIC outputs the DRAM's WE timing signals on the WE outputs. Since WE 3-WE 0 are controlled by the increment mode (IM 1, IM 0) and by the lower two bits of the address (MA 1, MA 0), the GMIC can directly control up to four memory banks. Up to eight memory banks can be controlled by externally decoding the address (ADRC) and WE 3-WE 0.

WE 3-WE 0 are bus driver that can handle a maximum output current I_{OL} of 24 mA.

Output Enable (OE): The GMIC outputs the DRAMs' output timing signal on the OE output. OE is a bus driver that can handle a maximum output current I_{OL} of 24 mA.

Frame Buffer Address (FA 7-FA 0): The GMIC outputs the multiplexed DRAM address on FA 7-FA 0. How the address is multiplexed depends on the increment mode (table 4). FA 7-FA 0 are bus drivers that can handle a maximum output current I_{OL} of 24 mA.

Address (ADRA-ADRC): The GMIC latches three address bits other than those delivered on the FA 7-FA 0 bits and outputs them on ADRA-ADRC in one memory cycle.

GVAC Control Signals

Shift Clock Enable (SCKE): The SCKE output controls the GVACs' video signal generation shift register. It outputs a control signal for zooming according to the horizontal zoom signal (attribute control signal) from the ACRTC. The GVAC performs horizontal zoom by halting the clock when SCKE is low.

Shift Load Signals (SLDB, SLDW): The SLDB and SLDW outputs are load signals for the display data of the video signal generation shift register. The SLDB output is used for single access mode, dual access mode 0, and dual access mode 1. The SLDW output controls the window screen in dual access mode 1.



Functional Description

Figure 2 is a block diagram of the HD63485.

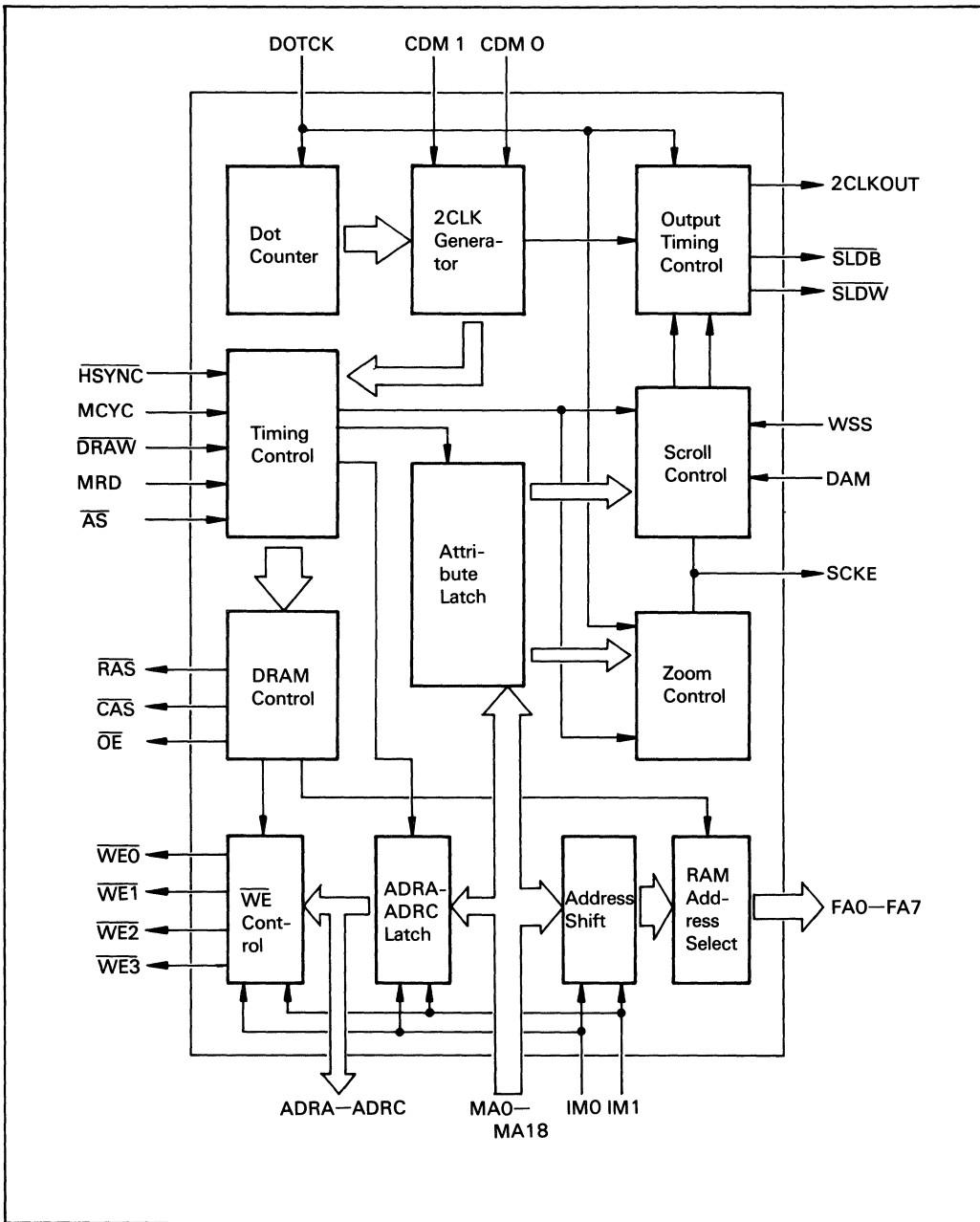

Figure 2. GMIC Block Diagram



2CLK Generator

The 2CLK generator generates 2CLKOUT for the ACRTC and itself by dividing the external DOTCK signal. The ratio of DOTCK to 2CLKOUT is set externally by the CDM 1 and CDM 0 inputs.

Attribute Latch

The attribute latch temporarily stores the attribute codes input from the ACRTC on MA 18-MA 0 used for horizontal zoom (HZ 3-HZ 0) and horizontal scroll dot (HSD 3-HSD 0).

Zoom Control

Zoom control generates the SCKE signal from DOTCK to control the GVAC clock for horizontal display zooming.

Scroll Control

Scroll control generates shift load signals ($\overline{\text{SLDB}}$, $\overline{\text{SLDW}}$) which control video signal generation for the GVAC.

Address Shifter

The address shifter stores memory addresses (MA 18-MA 0) sent from the ACRTC. It supplies them to the RAM address section according to the timesharing mode selected by the graphic increment mode (IM 1, IM 0).

ADRA-ADRC Latches

The ADRA-ADRC latches store the lower or upper address bits which are not supplied to FA 7-FA 0 from the memory address sent from the ACRTC. It outputs them for the whole memory cycle.

RAM Address Selection

The RAM address selection circuits output the timeshared row and column addresses to the frame buffers according to the $\overline{\text{RAS}}$ and $\overline{\text{CAS}}$ timing.

DRAM Control and $\overline{\text{WE}}$ Control

The DRAM and $\overline{\text{WE}}$ control circuits generate $\overline{\text{RAS}}$, $\overline{\text{CAS}}$, $\overline{\text{OE}}$, and $\overline{\text{WE}}$ signals for frame buffer access from the ACRTC output signals.

System Description

Applications

The GMIC provides communications between the ACRTC and frame buffers. It contains control circuits for generating signals necessary for the ACRTC to access a frame buffer. In addition it generates basic signals for operating the ACRTC and control signals for the GVAC (Graphic Video Attribute Controller), which generates the video signals for a CRT display.

The GMIC's operation mode can be controlled by its program pins. This makes the GMIC suitable for a wide range of operations, from small, low-speed systems to large, high-speed systems, and it allows it to flexibly change to suit system specification changes.

Figure 3 shows a graphic system configuration using an ACRTC, GMIC, and GVACs. Using a GMIC for interface to the frame buffers and GVACs for CRT video signal generation creates a flexible, high-performance graphic system with a minimum component count.

System Configuration

The typical graphic system application for the GMIC and GVAC shown in figure 3 uses two GVACs, but the number of GVACs used can be changed to accommodate CRT resolution and color/grey scale per pixel for various applications.

The GMIC receives memory addresses (MAD_{15} - MAD_0 , MA_{18} - MA_{16}), address strobe (\overline{AS}), memory cycle ($MCYC$), draw (\overline{DRAW}), memory read (MRD), and other ACRTC outputs, and generates control signals for the frame buffers. The frame buffers are generally constructed from DRAM, since graphic systems require large memory capacity frame buffers. The GMIC therefore uses a DRAM-compatible multiplexing system. Through this multiplexing, the GMIC delivers address outputs and control signals such as \overline{RAS} , \overline{CAS} , \overline{WE} , and \overline{OE} , acting as a direct interface between the ACRTC and the frame buffers. Furthermore, the GMIC generates a basic clock signal for the ACRTC ($2CLK$) by dividing the high-speed dot clock. It also generates control signals for the GVAC.

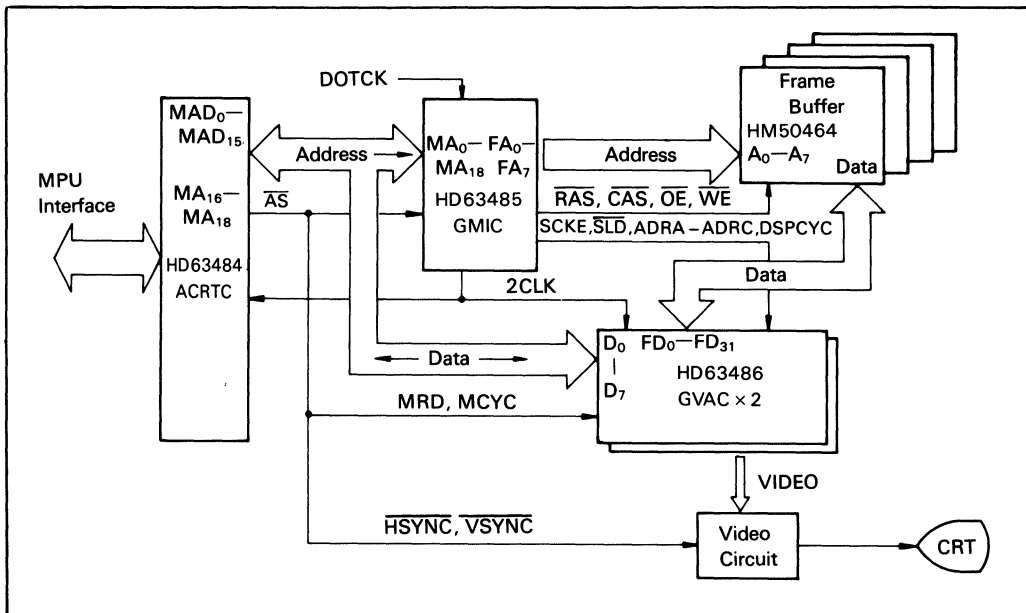

Figure 3. System Application Example



Operation

Basic Clock

Timing for signals to and from the GMIC is based on the dot clock (DOTCK) supplied to the GMIC and the clock output (2CLKOUT) generated by the GMIC. 2CLKOUT is generated by dividing the DOTCK input by the ratio selected by the CDM 1 and CDM 0 inputs. Figure 4 shows the relation between DOTCK and 2CLKOUT. The frequency of DOTCK depends on the speed and resolution of the CRT display. DOTCK (in MHz) equals the horizontal resolution (pixels/raster line) by the horizontal display raster scan period (μ s per raster).

$$f_{\text{DOTCK}} = \frac{[\text{Horizontal resolution (pixels/raster)}]}{[\text{Horizontal display period}(\mu\text{s})]} \text{ (MHz)}$$

The dot clock dividing mode should be chosen considering the frame buffer cycle time and the speed of the ACRTC used. For high-speed drawing, a smaller division ratio should be used to supply a

higher frequency clock to the ACRTC. For applications using low-speed frame buffers and external circuits, larger division ratios should be selected to supply a lower frequency clock to the ACRTC.

Note: The maximum DOTCK frequency is sometimes limited by the DOTCK division ratio. If the division ratio is 8 or 16, the maximum frequency is allowed, but if a division ratio of 4 is used, the DOTCK frequency is limited to 32 MHz.

Frame Buffer Control

The GMIC is designed for use with DRAM frame buffer memories. Therefore, the GMIC generates DRAM access signals RAS, CAS, WE, and OE. Also, it outputs row and column addresses to the RAM, timeshared according to RAS and CAS.

Table 5 shows the GMIC frame buffer access modes. The memory cycles are roughly divided into six types. They are distinguished by the ACRTC's

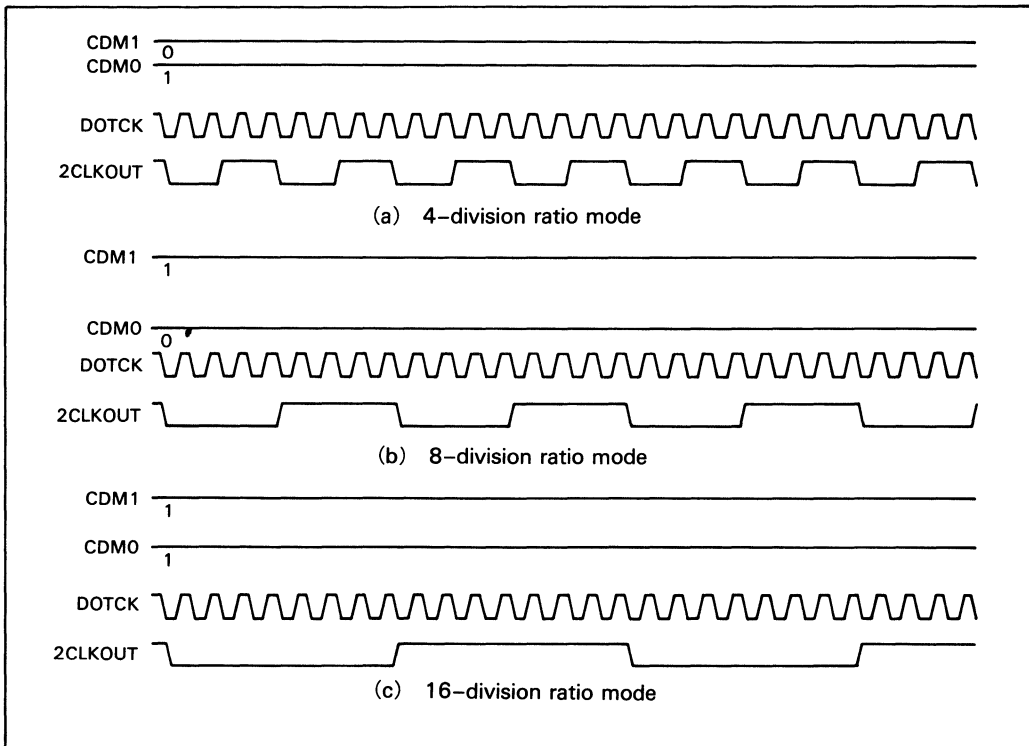

Figure 4. DOTCK Division



output signals (\overline{AS} , \overline{HSYNC} , \overline{DRAW} , \overline{MRD}).
 Figure 5 shows \overline{RAS} only refresh cycle timing.

Figure 6 and 7 show read and write cycle timing, respectively.

Table 5. Memory Cycles

\overline{AS}	\overline{HSYNC}	\overline{DRAW}	\overline{MRD}	Cycle Mode	Memory Cycle
Low pulse	Low	High	High	Refresh cycle	RAS only refresh
		Low	Low	Drawing write cycle	Memory write
		Low	High	Drawing read cycle	Memory read
	High	High	Low	Window screen cycle	Memory read
		High	High	Background screen display	Memory read
High	High	High	High		No access

Note: The GMIC performs a frame buffer refresh during a horizontal sync period (\overline{HSYNC} =low), with \overline{DRAW} high and \overline{AS} pulse applied. During a refresh cycle, only \overline{RAS} is output. \overline{CAS} and \overline{OE} are not output.

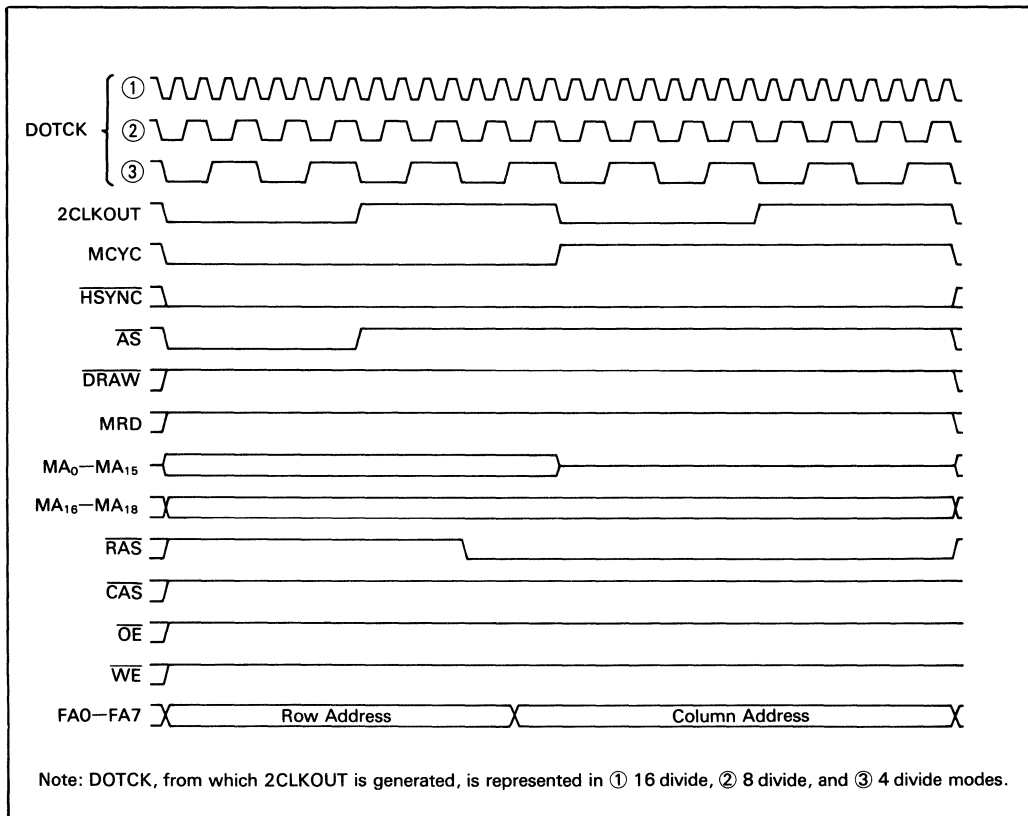

Figure 5. \overline{RAS} Only Refresh Timing



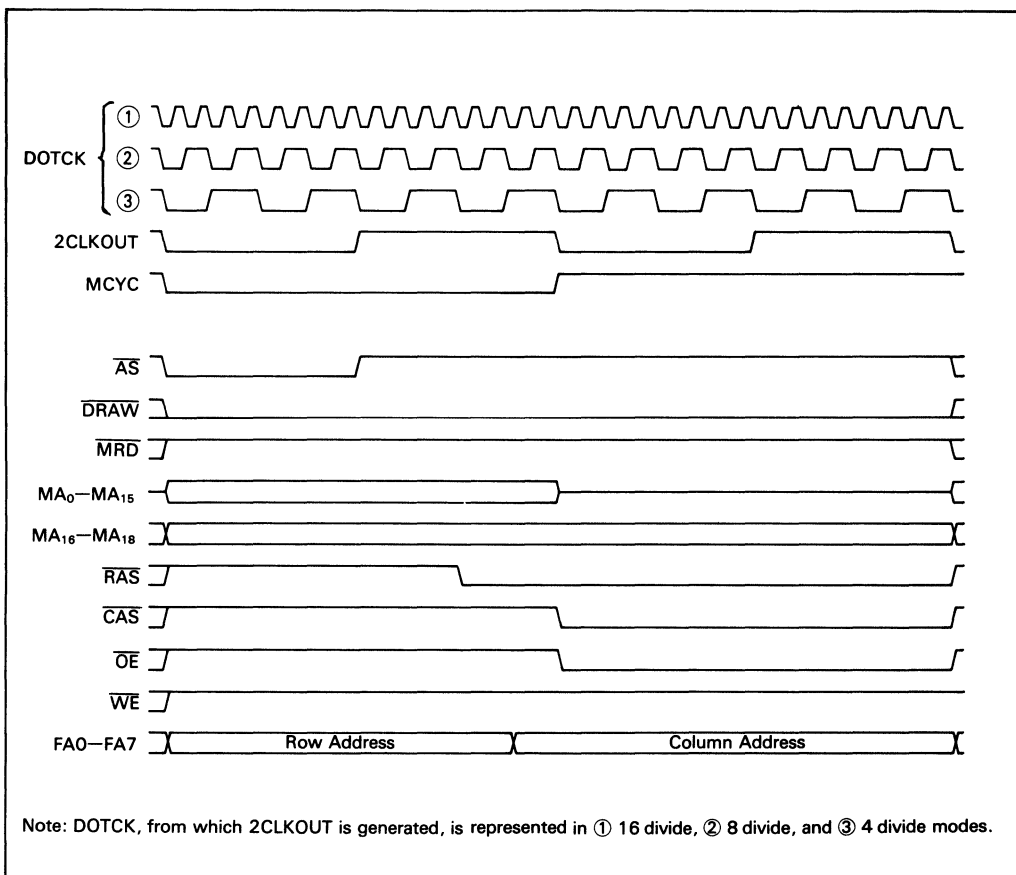
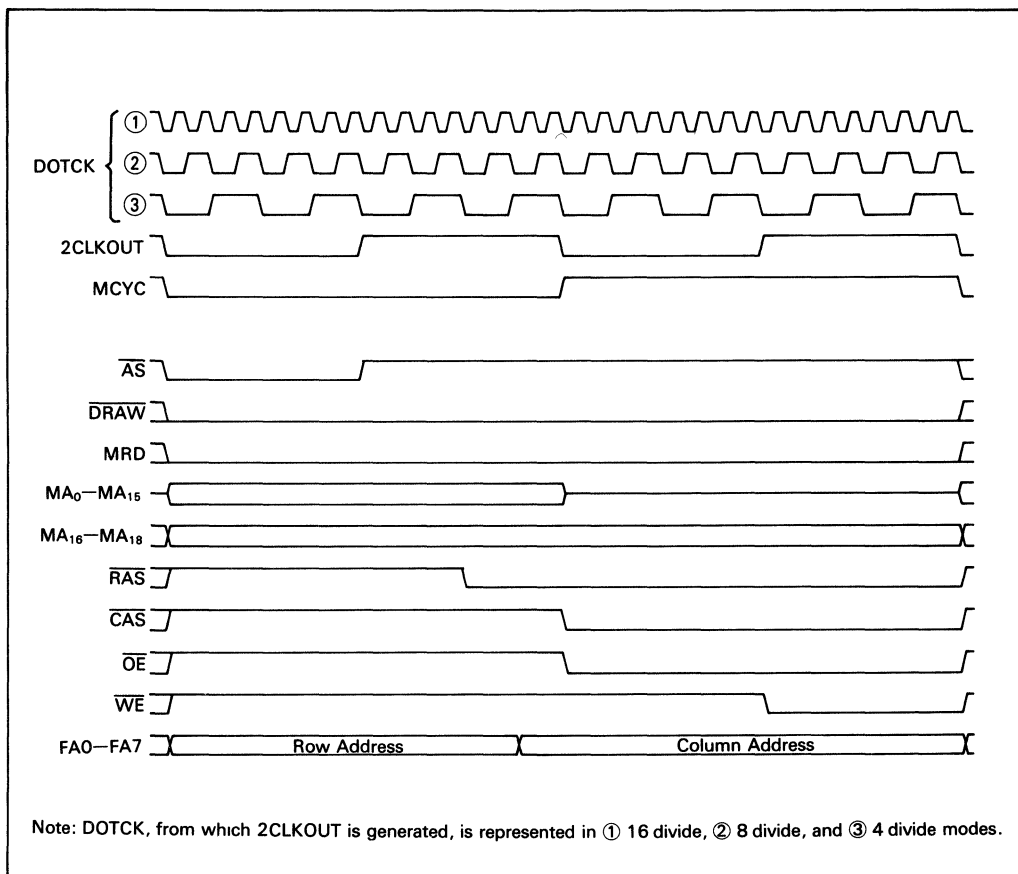

Figure 6. Read Cycle Timing



Note: DOTCK, from which 2CLKOUT is generated, is represented in ① 16 divide, ② 8 divide, and ③ 4 divide modes.

Figure 7. Write Cycle Timing

Table 6 shows the relation between frame buffer addresses (FA7-FA0) and memory address (MA₁₈-MA₀), as determined by the increment mode (IM1, IM0). FA pins provide multiplexed addresses for DRAM, and the remaining address bits are output at ADRA-ADRC. The GMIC has four increment modes: +1, +2, +4, and +8. This mode should be set the same as the ACRTC's GAI (graphic address increment) mode. GAI mode is a bit set according to the frame buffer, which sets the increment mode for display address output for a graphic address.

Graphic drawing data is processed on a single word (16 bit) basis. The ACRTC sets the bit count per pixel by the graphic bit mode (GBM) in its command control register, which is more suitable for multicolor/grey scale systems. However, if one word is definitely read from a frame buffer during each display cycle, four pixels per word can be displayed when GBM is set to 4 bits per pixel. To

implement a CRT display having a 1 bit per pixel resolution (16 pixels/word), an input clock four times faster must be supplied to the ACRTC. For more multicolor/grey scale systems, an ever faster clock is required.

On the other hand, if several words are read from a frame buffer during each display cycle, and the CRT can have a higher resolution without speeding up the ACRTC input clock. For example, in the +4 increment mode, when GBM is set to 4 bits/pixel, 4 words (64 bits) containing 16 pixels can be read in one display cycle.

For one word (16 bits) read during one display cycle, the GAI must be set to 000.

When 32/64/128 bits are required during one display cycle for a high-resolution or multicolor/grey scale system, GAI must be set to 001/010/011

Table 6. Frame Buffer and Memory Addresses

Frame Address	+1 Mode		+2 Mode		+3 Mode		+4 Mode	
	Row	Col	Row	Col	Row	Col	Row	Col
FA0	MA0	MA8	MA1	MA9	MA2	MA10	MA3	MA11
FA1	MA1	MA9	MA2	MA10	MA3	MA11	MA4	MA12
FA2	MA2	MA10	MA3	MA11	MA4	MA12	MA5	MA13
FA3	MA3	MA11	MA4	MA12	MA5	MA13	MA6	MA14
FA4	MA4	MA12	MA5	MA13	MA6	MA14	MA7	MA15
FA5	MA5	MA13	MA6	MA14	MA7	MA15	MA8	MA16
FA6	MA6	MA14	MA7	MA15	MA8	MA16	MA9	MA17
FA7	MA7	MA15	MA8	MA16	MA9	MA17	MA10	MA18
ADRA	MA16		MA0		MA0		MA0	
ADRB	MA17		MA17		MA1		MA1	
ADRC	MA18		MA18		MA18		MA2	

Table 7. \overline{WE} Output Timing

Increment Mode	DRAW	Input					Output			
		MRD	MA1	MA0	IM1	IM0	WE3	WE2	WE1	WE0
	H	x	x	x	x	x	H	H	H	H
	L	H	x	x	x	x	H	H	H	H
+1	L	L	x	x	0	0	L	L	L	L
	L	L	x	0	0	1	H	L	H	L
+2	L	L	x	1	0	1	L	H	L	H
	L	L	0	0	1	x	H	H	H	L
+4/+8	L	L	0	1	1	x	H	H	L	H
	L	L	1	0	1	x	H	L	H	H
	L	L	1	1	1	x	L	H	H	H
	L	L	1	1	1	x	L	H	H	H



respectively.

Table 7 shows the output condition of the write enable signals $\overline{WE3}$ - $\overline{WE0}$. The four write enable signals can directly control up to four memory banks. The \overline{WE} output is determined by \overline{DRAW} , MA0, IM1, and IM0.

Video Shifter Shift Load Signals (\overline{SLDB} , \overline{SLDW})

\overline{SLDB} and \overline{SLDW} load timing signals control the timing of display data input from a frame buffer to the video signal generation shift register (parallel-to-serial conversion circuit). \overline{SLDB} is used for base screen in single access mode, dual access mode 0, and dual access mode 1. \overline{SLDW} is used for window screens in dual access mode 1.

Relation of Access Mode and WSS to \overline{SLDB} and \overline{SLDW} : Table 8 shows the relationship between access modes, WSS, and \overline{SLDB} and \overline{SLDW} . When WSS=0 in single access or dual access mode 0, \overline{SLDB} output timing can be varied according to the amount of scrolling for one display cycle. \overline{SLDW} is not output.

When WSS=0 in dual access mode 1 for the base screen, \overline{SLDB} output timing can be varied to accommodate smooth scrolling according to the horizontal scroll dot attribute control signals (HSD3-HSD0) supplied by the ACRTC. The

\overline{SLDW} signal is asserted for one period of the last dot clock during a display cycle. Its output cannot be varied for scrolling.

When WSS=1, for the window in dual access mode 1, \overline{SLDB} signal is asserted and fixed for one period of the last dot clock of one display cycle, where as \overline{SLDW} timing can be varied according to scrolling amount in one display cycle.

Amount of Scrolling and Output Timing: Figure 8 shows the output timing of the shift load signals (\overline{SLDB} , \overline{SLDW}) for different amounts of scrolling. With increased scrolling, the load signal is output earlier by one dot clock.

Figure 9, 10, and 11 show \overline{SLDB} and \overline{SLDW} timing for single access, dual access mode 0, and dual access mode 1, respectively. Figure 12, 13, and 14 show \overline{SLDB} timing for double and triple zooming.

Table 9 shows the attribute codes set for the ACRTC and the corresponding scrolling amounts. Table 10 shows the relationship between the GMIC dot clock division ratios and GVAC shift register lengths in corresponding access modes. Display colors are determined by the shift register length and amount of display data simultaneously read set in the ACRTC's GAI. The single and dual access modes are described in the ACRTC User's Manual, Section 3.2 CRT Interface.

Table 8. WSS, Access Mode, Shift Load Signals

WSS	Access Mode	\overline{SLDB}	\overline{SLDW}
0	Single access, Dual access 0	Scrolling amount is permitted	No output
	Dual access 1, Base screen	Scrolling amount is permitted	Scrolling impossible
1	Dual access 1, Base screen	Scrolling impossible	Scrolling amount is permitted

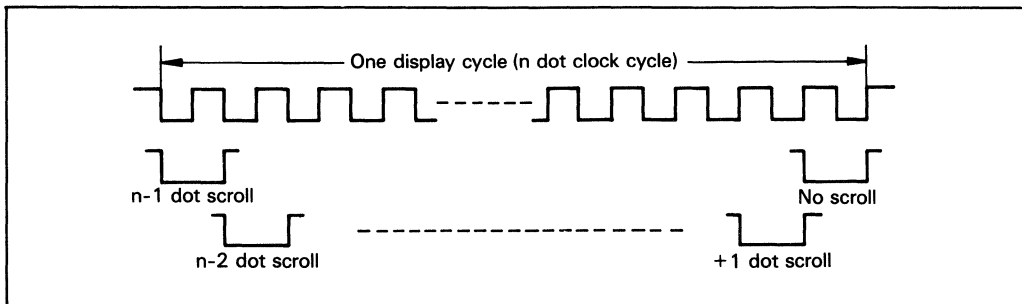

Figure 8. Shift Load (\overline{SLDB} , \overline{SLDW}) Output Timing



Table 9. ACRTC Attribute Codes and Scrolling Amounts

Shift Bit Length	HSD5	HSD4	HSD3	HSD2	HSD1	HSD0	Scroll Dot Count
16 bits	x	x	0	0	0	0	0
	x	x	0	0	0	1	1
	x	x	0	0	1	0	2
32 bits	x	x	1	1	1	0	14
	x	x	1	1	1	1	15
	x	0	0	0	0	0	0
	x	0	0	0	0	1	1
	x	0	0	0	1	0	2
64 bits	x	1	1	1	1	0	30
	x	1	1	1	1	1	31
	0	0	0	0	0	0	0
	0	0	0	0	0	1	1
	0	0	0	0	1	0	2
	1	1	1	1	1	0	62
	1	1	1	1	1	1	63

Note: The attribute code from the ACRTC supplies HSD3-HSD0, and memory address MA1 and MA0 supply HSD5 and HSD4. If these memory address bits are used (MA1 for 64-bit shifts, MA0 for 32-bit shifts), they must not be changed during one horizontal period

Table 10. GMIC Division Ratio and GVAC Shift Lengths

Division Ratio	Single Access	Dual Access
Divide by 4	8 dot shift	16 dot shift
Divide by 8	16 dot shift	32 dot shift
Divide by 16	32 dot shift	64 dot shift (note)

Note: This mode cannot be used directly because the maximum shift register length is 32 dots

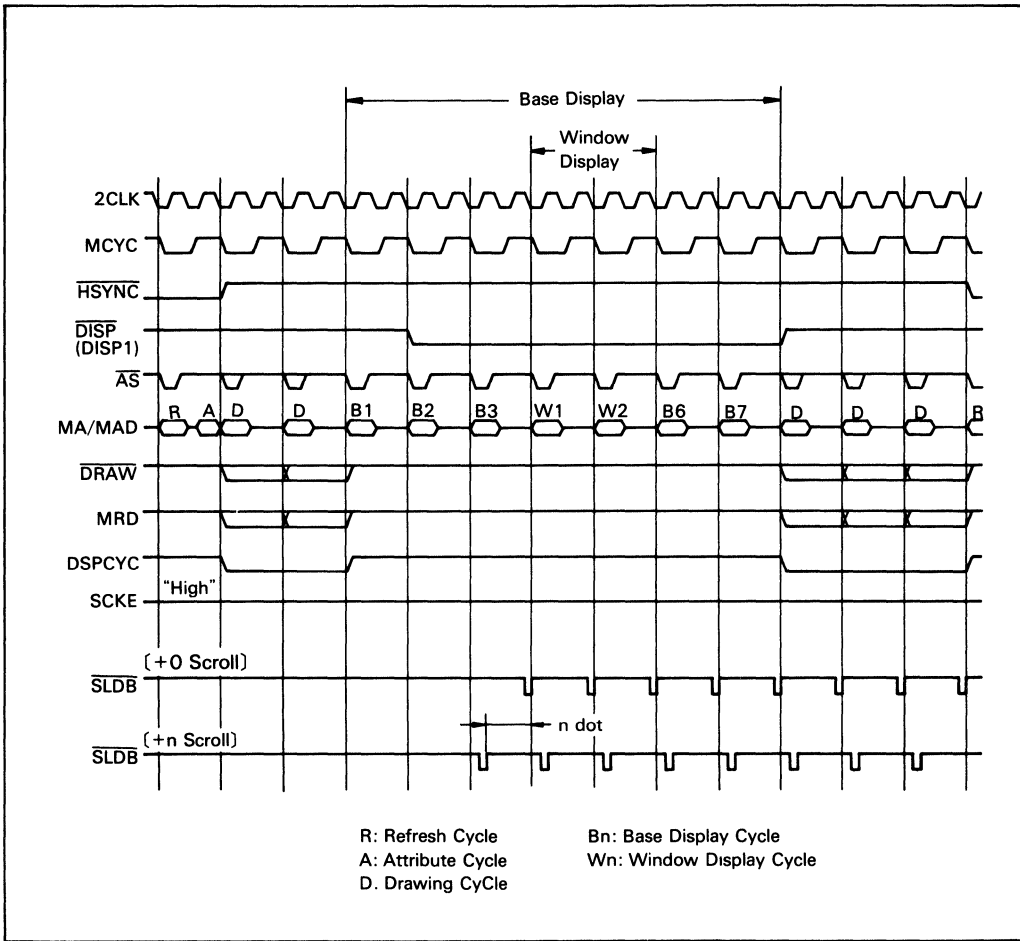

Figure 9. SLDB Timing (Single Access Mode)

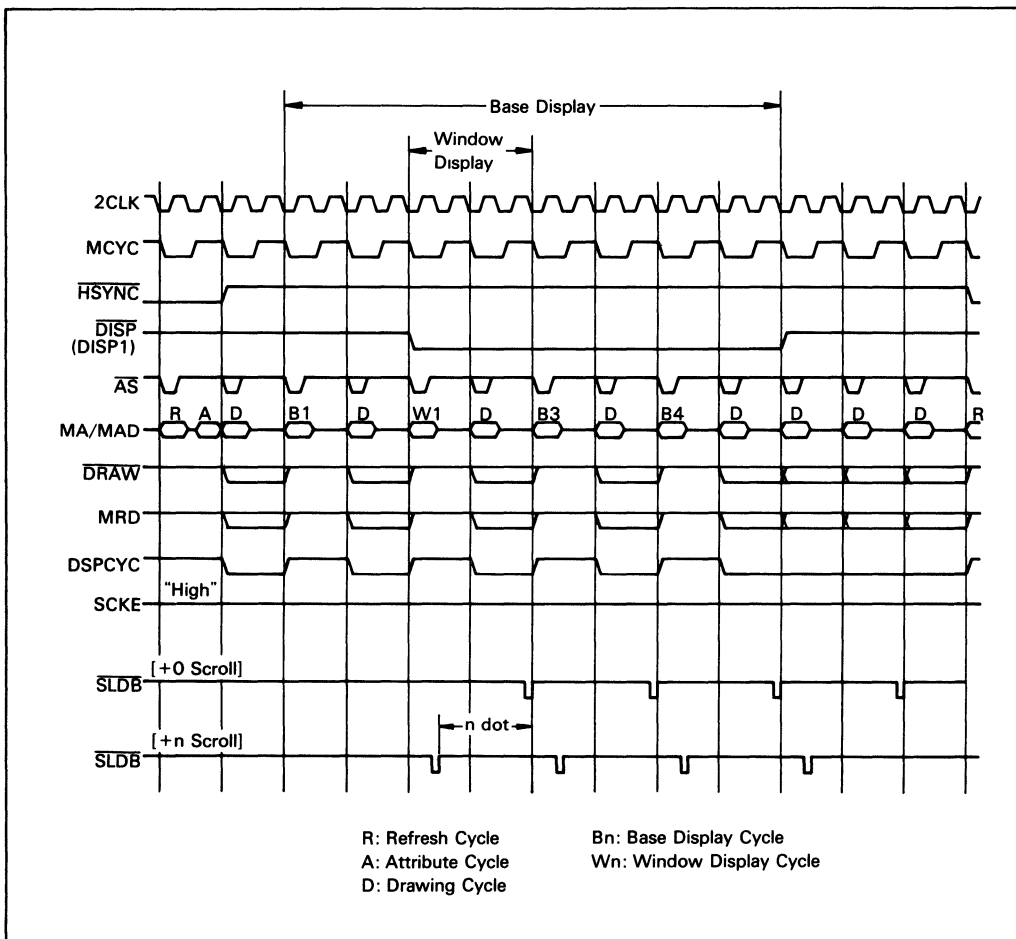

Figure 10. SLDB Timing (Dual Access Mode 0)

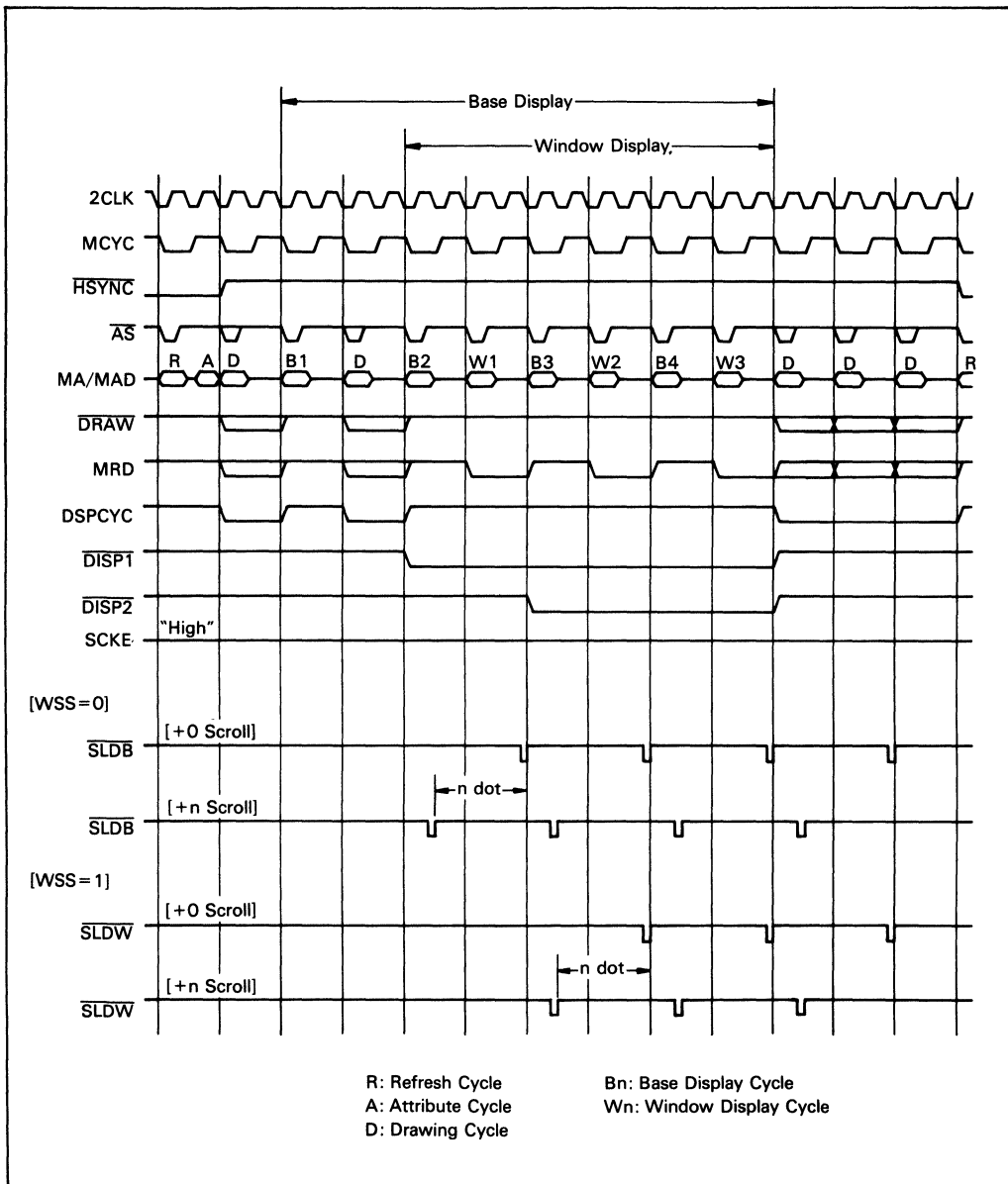

Figure 11. \overline{SLDB} and \overline{SLDW} Timing (Dual Access Mode 1)

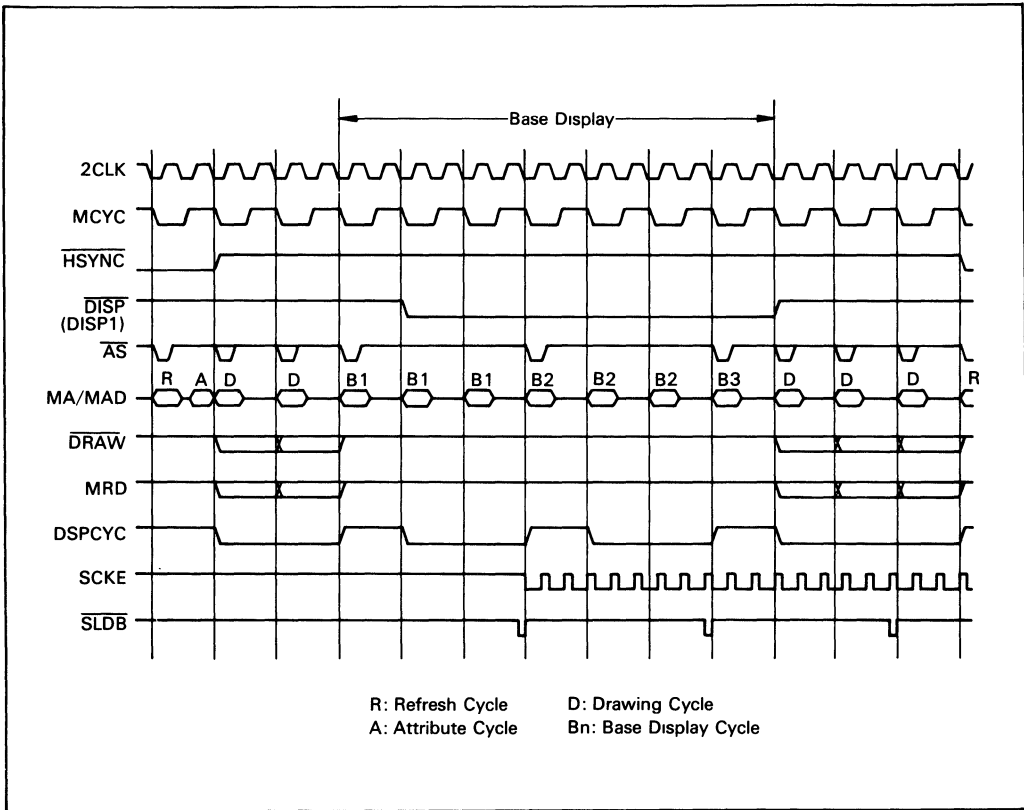

Figure 12. Zoom Display Timing (Single Access Mode, Triple Zoom)

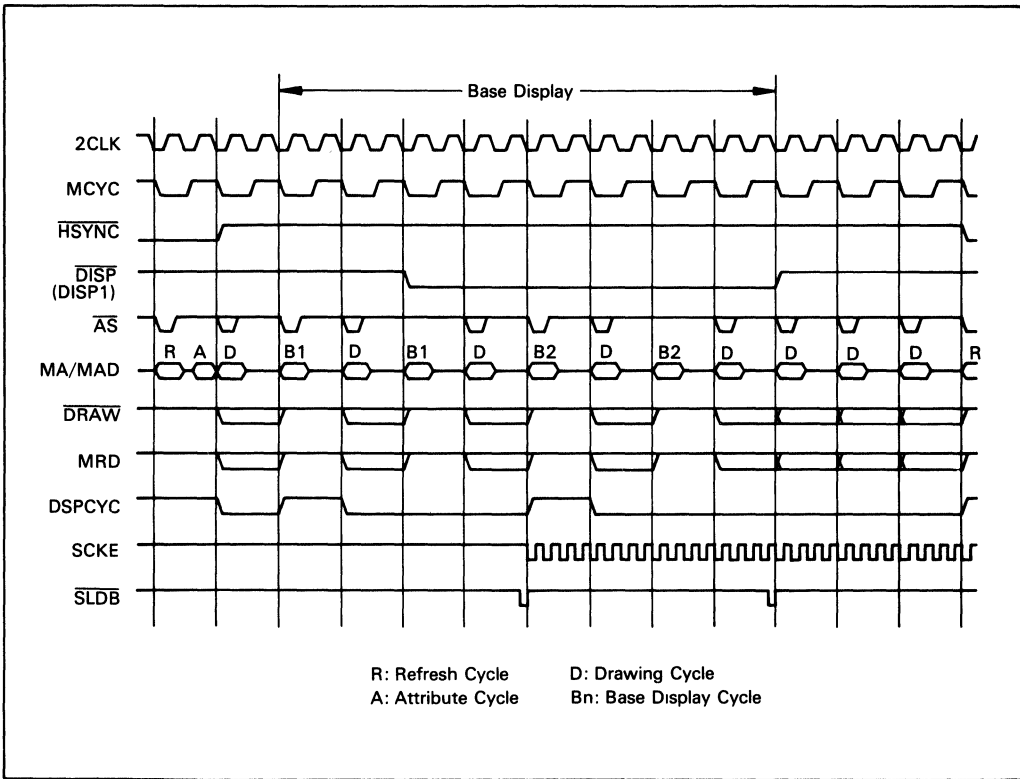

Figure 13. Zoom Display Timing (Dual Access Mode 0, Double Zoom)

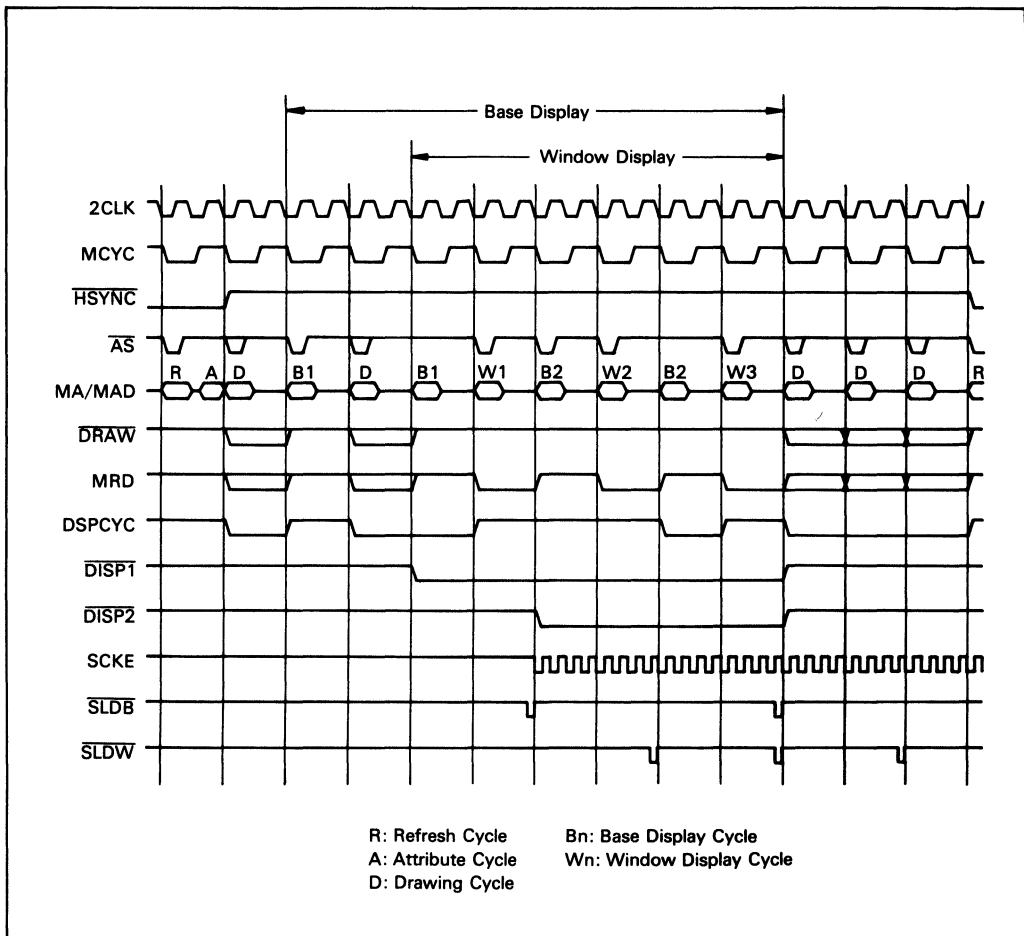

Figure 14. Zoom Display Timing (Dual Access Mode 1, Double Zoom)

Driving Priority Mode : In the ACRTC drawing priority mode, drawing memory access takes priority over display memory access. In this mode, when display data is provided in the same manner as in the 32-bit shift mode but the system does not enter a display cycle, and a total output of 32 bits is completed, low-level output are provided until the next display cycle.

Shift Clock Enable (SCKE)

Shift clock enable (SCKE) is a control signal for the GVAC video signal generation shift register. GVAC drives the shift register on the falling edge of the dot clock. The SCKE control signal decreases the dot clock frequency to set the zoom scale. Figure 15 shows triple zoom (HZ=0011) timing. Table 11 shows attribute codes and corresponding zoom scales.

Table 11. Attribute Codes and Zoom Scales

HZ3	HZ2	HZ1	HZ0	Zoom scale
0	0	0	0	1
0	0	0	1	2
0	0	1	0	3
0	0	1	1	4
0	1	0	0	5
0	1	0	1	6
0	1	1	0	7
0	1	1	1	8
1	0	0	0	9
1	0	0	1	10
1	0	1	0	11
1	0	1	1	12
1	1	0	0	13
1	1	0	1	14
1	1	1	0	15
1	1	1	1	16

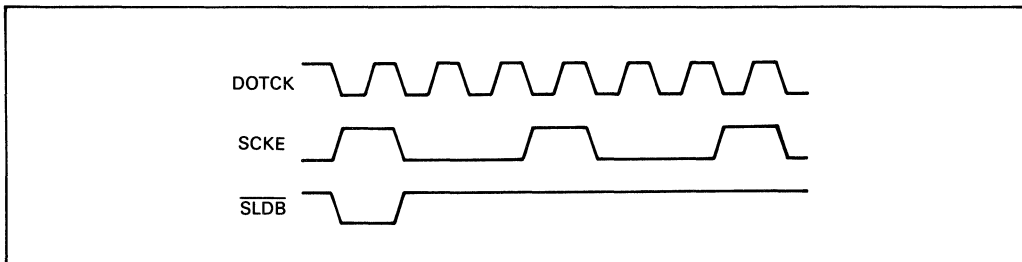

Figure 15. Triple Zoom Timing

Attribute Control Signals

The GMIC receives attribute code control signals for horizontal zooming and horizontal smooth scrolling from the ACRTC. Figure 16 shows attribute control output timing, and figure 17 shows the corresponding output pins.

The GMIC can control horizontal smooth scrolling of up to a 63-dot shift. However, the ACRTC outputs a 4-bit code (HSD3-HSD0), directly supporting up to a 15-dot shift. Therefore, the GMIC latches the lower 2 bits of the display cycle address (MA0, MA1) output every display cycle into its internal register in order to control a 63-dot shift.

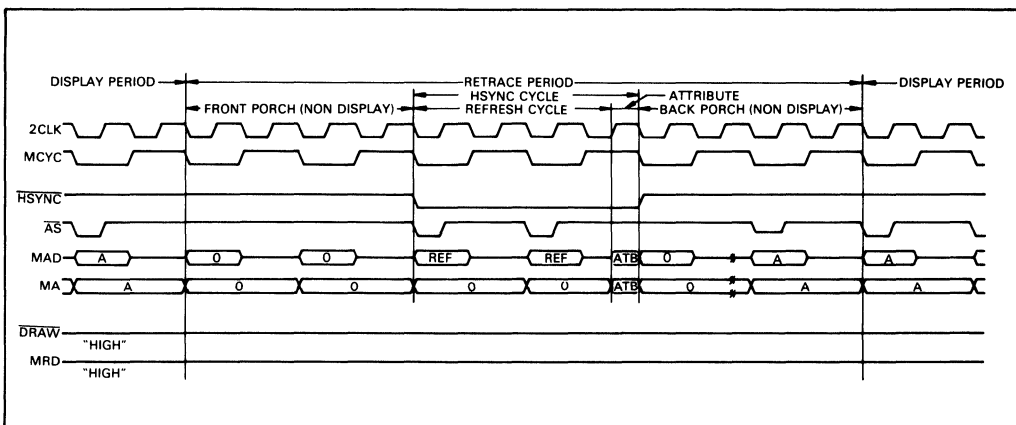

Figure 16. DRAM Refresh and Attribute Control Data Output (Single Access Mode)

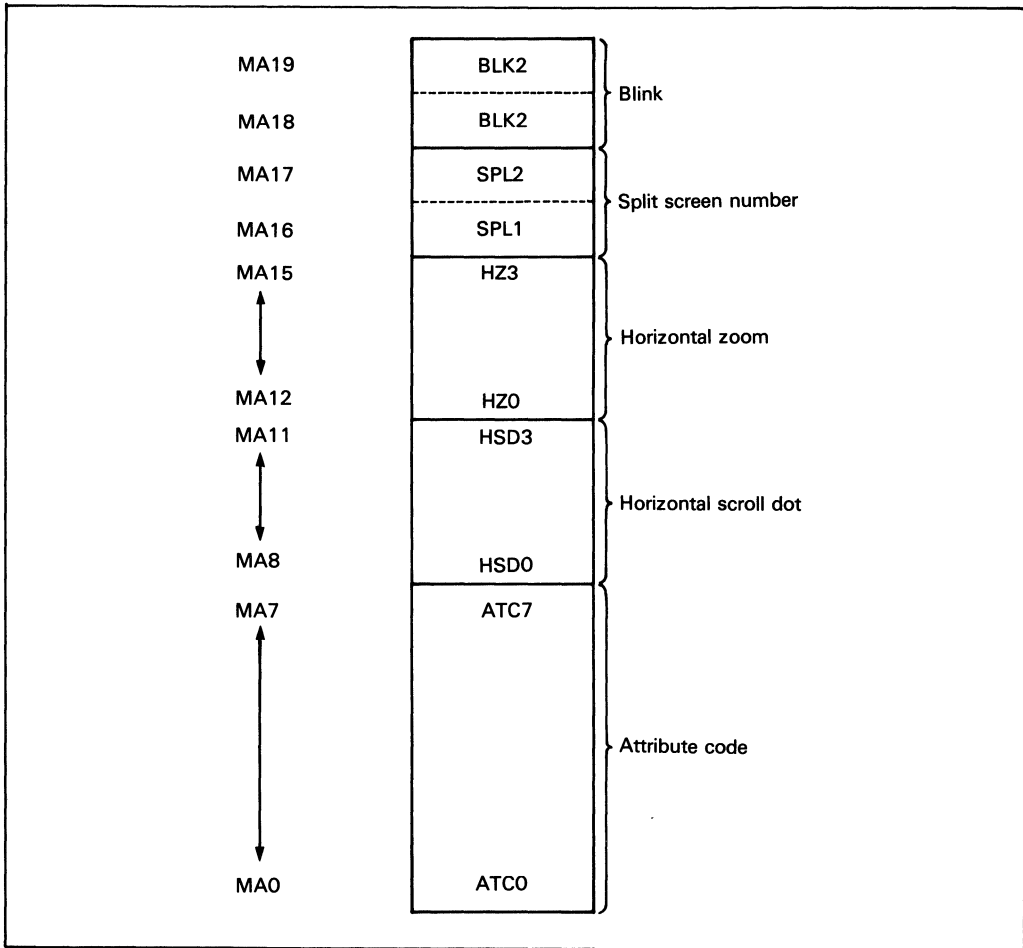

Figure 17. Attribute Control Signal Output Pins

Absolute Maximum Ratings (All voltages referenced to $V_{SS} = 0\text{ V}$)

Item	Symbol	Rating	Unit
Supply voltage	V_{CC}	- 0.3 to + 7.0	V
Input voltage	V_{in}	- 0.3 to $V_{CC} + 0.3$	V
Output voltage	V_{out}	5.5	V
Operating temperature	T_{opr}	0 to + 70	°C
Storage temperature	T_{str}	- 55 to + 150	°C

Notes: Using an LSI beyond in maximum ratings may result in its permanent destruction. LSIs should usually be operated under the recommended operating conditions. Exceeding any of these conditions may adversely affect its reliability.

Recommended Operating Conditions (All voltages referenced to $V_{SS} = 0\text{ V}$)

Item	Symbol	Min	Typ	Max	Unit
Supply voltage	V_{CC}	4.75	5.00	5.25	V
Input voltage low	V_{IL}	0	—	0.7	V
Input voltage high	V_{IH}	2.2	—	V_{CC}	V
Operating temperature	T_{opr}	0	25	70	°C

Electrical Characteristics

DC Characteristics ($V_{CC} = 5.0 \text{ V} \pm 5\%$, $V_{SS} = 0 \text{ V}$, $T_a = 0^\circ\text{C}$ to 70°C unless otherwise noted)

Item		Symbol	Min	Max	Unit	Test Condition
Input voltage high		V_{IH}	2.2	V_{CC}	V	
Input voltage low		V_{IL}	-0.3	0.7	V	
Input clamp voltage		V_I		-1.5	V	$V_{CC} = 4.75 \text{ V}$, $I_{in} = -18 \text{ mA}$
Output voltage high	ADRA-ADRC, SLDB, SLDW, DSPCYC, SCKE, 2CLKOUT	V_{OH}	2.7		V	$V_{CC} = 4.75 \text{ V}$, $I_{OH} = -400 \text{ mA}$
	$\overline{WE3}$ - $\overline{WE0}$, FA7-FA0, RAS, CAS, OE	V_{OH}	2.0		V	$V_{CC} = 4.75 \text{ V}$, $I_{OH} = -15 \text{ mA}$
Output voltage low	ADRA-ADRC, SLDB, SLDW, DSPCYC, SCKE 2CLKOUT	V_{OL}		0.5	V	$V_{CC} = 4.75 \text{ V}$, $I_{OL} = 8 \text{ mA}$
	$\overline{WE3}$ - $\overline{WE0}$, FA7-FA0, RAS, CAS, OE	V_{OL}		0.5	V	$V_{CC} = 4.75 \text{ V}$, $I_{OL} = 24 \text{ mA}$
Input current high		I_{IH}		20	μA	$V_{CC} = 5.25 \text{ V}$, $V_I = 2.7 \text{ V}$
Input current low		I_{IL}		-400	μA	$V_{CC} = 5.25 \text{ V}$, $V_I = 0.4 \text{ V}$
Output short circuit current		I_{OS}	-40	-120	mA	$V_{CC} = 5.25 \text{ V}$
Current consumption		I_{CC}		160	mA	$V_{CC} = 5.25 \text{ V}$
Input capacitance		C_{in}		10	pF	

AC Characteristics ($V_{CC} = 5.0 \text{ V} \pm 5\%$, $V_{SS} = 0 \text{ V}$, $T_a = 0^\circ\text{C}$ to $+70^\circ\text{C}$)

No	Item	Symbol	32 MHz		48 MHz		64 MHz		Unit	Figure
			Min	Max	Min	Max	Min	Max		
	DOTCK operation frequency	f	32		48		64		MHz	
①	DOTCK cycle time	t_c	31.3		20.8		15.6		ns	18
②	DOTCK high level pulse width	t_{HW}	12		9		6		ns	
③	DOTCK low level pulse width	t_{LW}	12		9		6		ns	
④	DOTCK rise time	t_R	5		5		5		ns	
⑤	DOTCK fall time	t_F	5		5		5		ns	
⑥	2CLKOUT delay	t_{2CLKD}	24		17		14		ns	19
⑦	MCYC setup time	t_{MCYCS}	$t_c + 20$		$t_c + 20$		$t_c + 20$		ns	20-23
⑧	MCYC hold time	t_{MCYCH}	0		0		0		ns	
⑨	HSYNC setup time	t_{HSS}	$t_c + 20$		$t_c + 20$		$t_c + 20$		ns	20-22
⑩	HSYNC hold time	t_{HSH}	0		0		0		ns	23
⑪	MRD setup time	t_{MRDS}	$t_c + 20$		$t_c + 20$		$t_c + 20$		ns	20-22
⑫	MRD hold time	t_{MRDH}	5		5		5		ns	20, 21, 23
⑬	DRAW setup time	t_{DRAWS}	$t_c + 20$		$t_c + 20$		$t_c + 20$		ns	20-22
⑭	DRAW hold time	t_{DRAWH}	5		5		5		ns	20, 21, 23
⑮	AS setup time (CDM = 01)	t_{ASS}	$t_c + 25$		$t_c + 25$		$t_c + 25$		ns	20-23
	AS setup time (CMD = 10)	t_{ASS}	$2t_c + 25$		$2t_c + 25$		$2t_c + 25$		ns	
	AS setup time (CDM = 11)	t_{ASS}	$4t_c + 25$		$4t_c + 25$		$4t_c + 25$		ns	
⑯	AS pulse width	t_{ASW}	25		25		25		ns	
⑰	Memory address setup time	t_{MAS}	10		10		10		ns	20-23
⑱	Memory address hold time	t_{MAH}	5		5		5		ns	
⑲	Attribute code setup time	t_{ACS}	20		20		20		ns	23
⑳	Attribute code hold time	t_{ACH}	5		5		5		ns	

AC Characteristics (cont)

No	Item	Symbol	32 MHz		48 MHz		64 MHz		Unit	Figure
			Min	Max	Min	Max	Min	Max		
21	RAS setup time (CDM = 01)	trSS	tc - 20		tc - 20		tc - 20		ns	20-23
	RAS setup time (CDM = 10)	trSS	2tc - 20		2tc - 20		2tc - 20		ns	
	RAS setup time (CDM = 11)	trSS	4tc - 20		4tc - 20		4tc - 20		ns	
22	RAS hold time	trSH	3		3		3		ns	
23	CAS delay time (CDM = 01)	tcASD	tc - 7		tc - 7		tc - 7		ns	20, 21
	CAS delay time (CDM = 10)	tcASD	2tc - 7		2tc - 7		2tc - 7		ns	
	CAS delay time (CDM = 11)	tcASD	4tc - 7		4tc - 7		4tc - 7		ns	
23A	CAS delay time from 2CLK	tcASDH		20		20		15	ns	
24	CAS hold time	tcASH	3		3		3		ns	
25	Memory address setup time (CDM = 01)	tmASC	tc + 25		tc + 25		tc + 25		ns	20-23
	Memory address setup time (CDM = 10)	tmASC	2tc + 25		2tc + 25		2tc + 25		ns	
	Memory address setup time (CDM = 11)	tmASC	4tc + 25		4tc + 25		4tc + 25		ns	
26	Row address setup time	trAS	0		0		0		ns	
27	Row address hold time (CDM = 01)	trAH	tc/2 - 2		tc/2 - 2		tc/2 - 2		ns	
	Row address hold time (CDM = 10)	trAH	tc - 2		tc - 2		tc - 2		ns	
	Row address hold time (CDM = 11)	trAH	2tc - 2		2tc - 2		2tc - 2		ns	
28	Column address setup time	tcAS	0		0		0		ns	20, 21
29	Column address hold time	tCAH	0		0		0		ns	



AC Characteristics (cont)

No	Item	Symbol	32 MHz		48 MHz		64 MHz		Unit	Figure
			Min	Max	Min	Max	Min	Max		
⑩	\overline{OE} delay time	tOED		20		20		20	ns	20
⑪	\overline{OE} hold time	tOEH	3		3		3		ns	
⑫	\overline{WE} delay time	tWED	5	30	5	30	5	30	ns	21
⑬	\overline{WE} hold time	tWEH	3		3		3		ns	
⑭	Address delay time	tAD		30		30		30	ns	
⑮	Address hold time	tAH	0		0		0		ns	
⑯	SCKE delay time	tSCKD	3	22	3	15	3	12	ns	18
⑰	SLD delay time	tSLDD	5	24	5	17	5	17	ns	
⑱	DSPCYC delay time from AS	tDSPDA		40		40		40	ns	20
⑳A	DSPCYC delay time from DRAW	tDSPDD		20		20		20	ns	
㉑	DSPCYC hold time	tDSPH	5		5		5		ns	

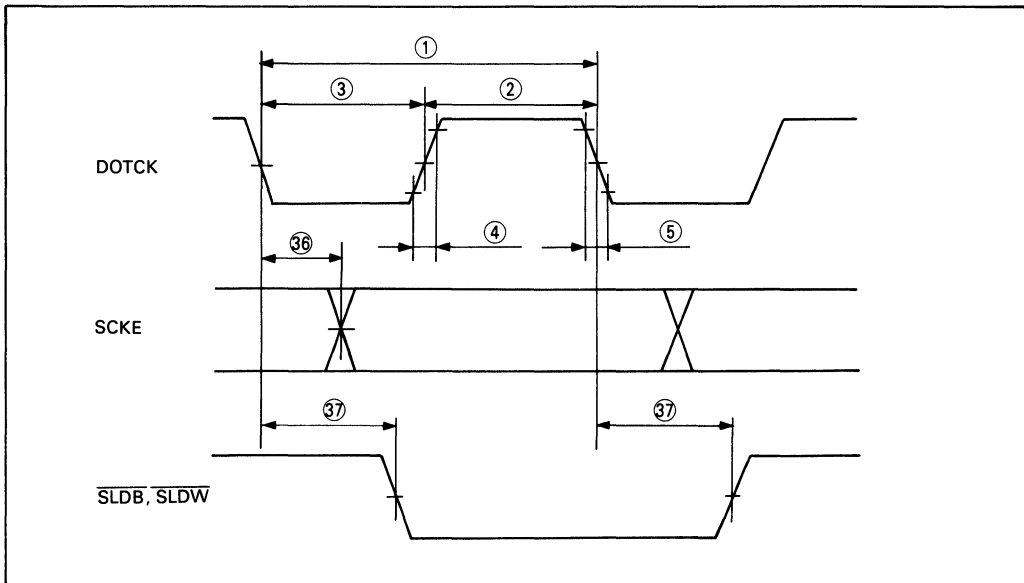

Figure 18. Clock

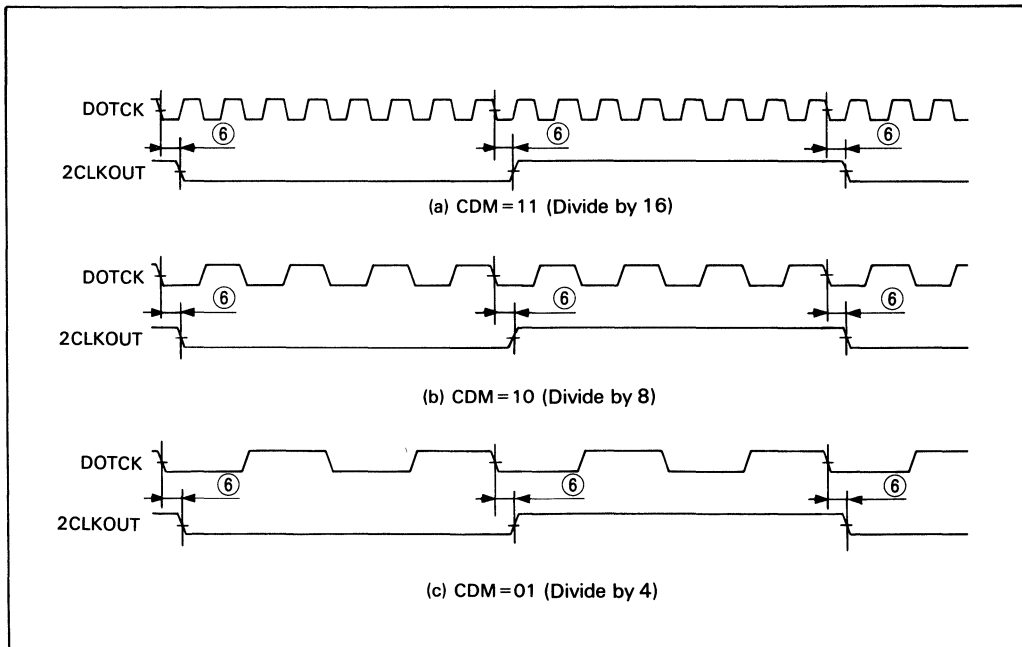

Figure 19. 2CLKOUT



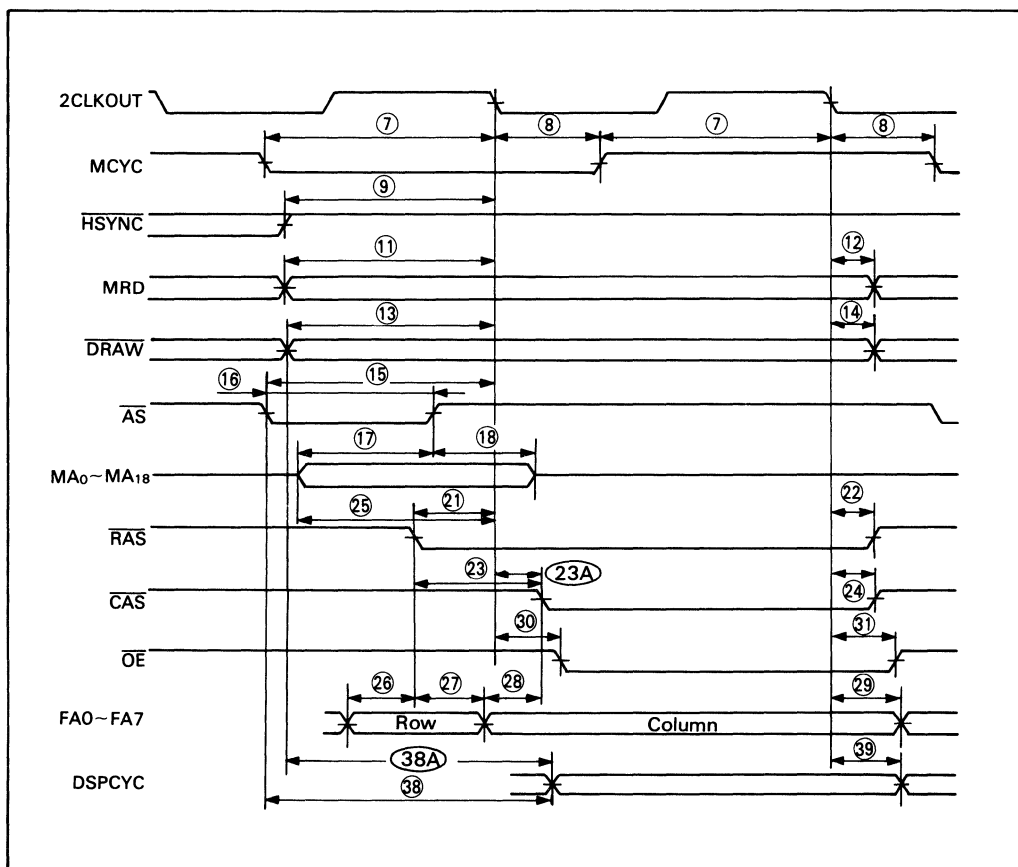

Figure 20. Memory Read Cycle (Drawing Read and Display)

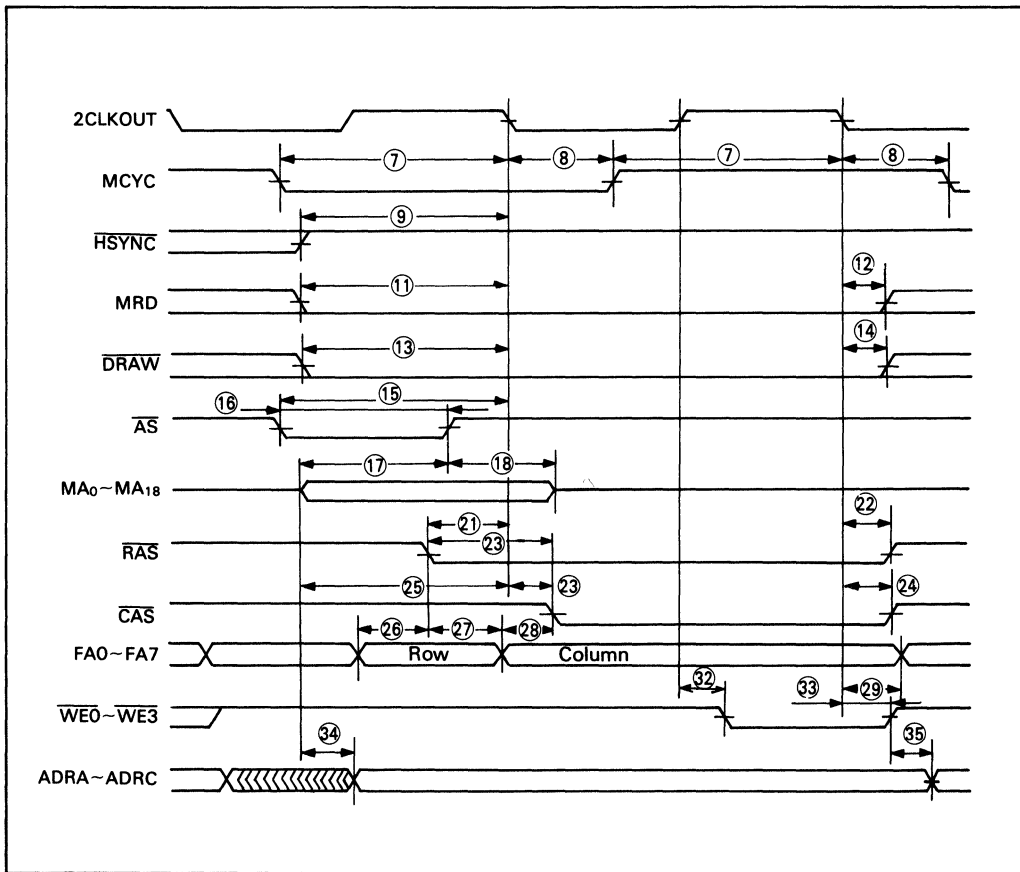

Figure 21. Memory Write Cycle

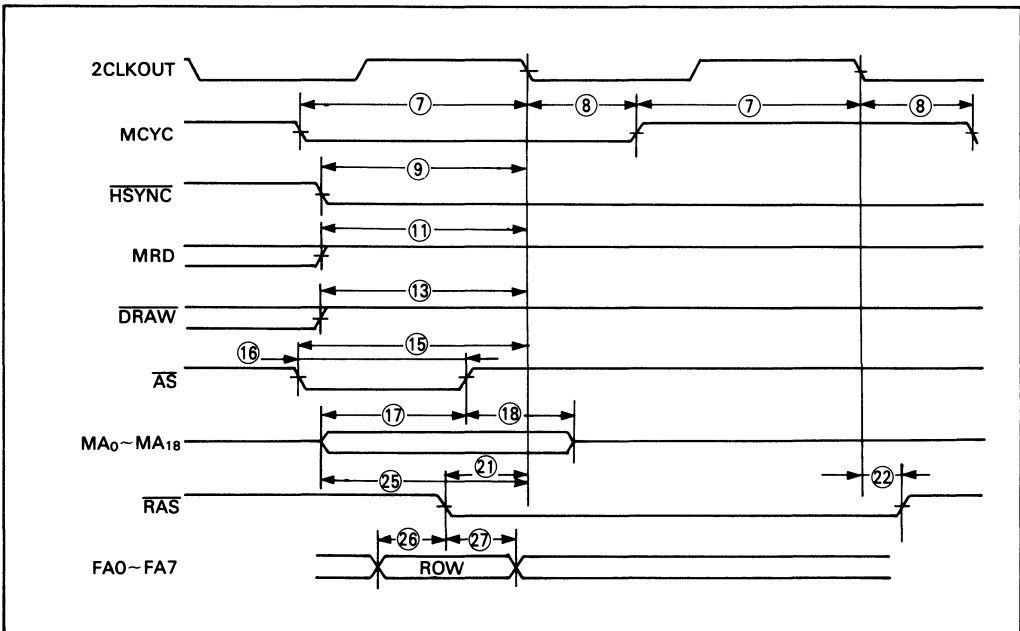

Figure 22. Refresh Cycle

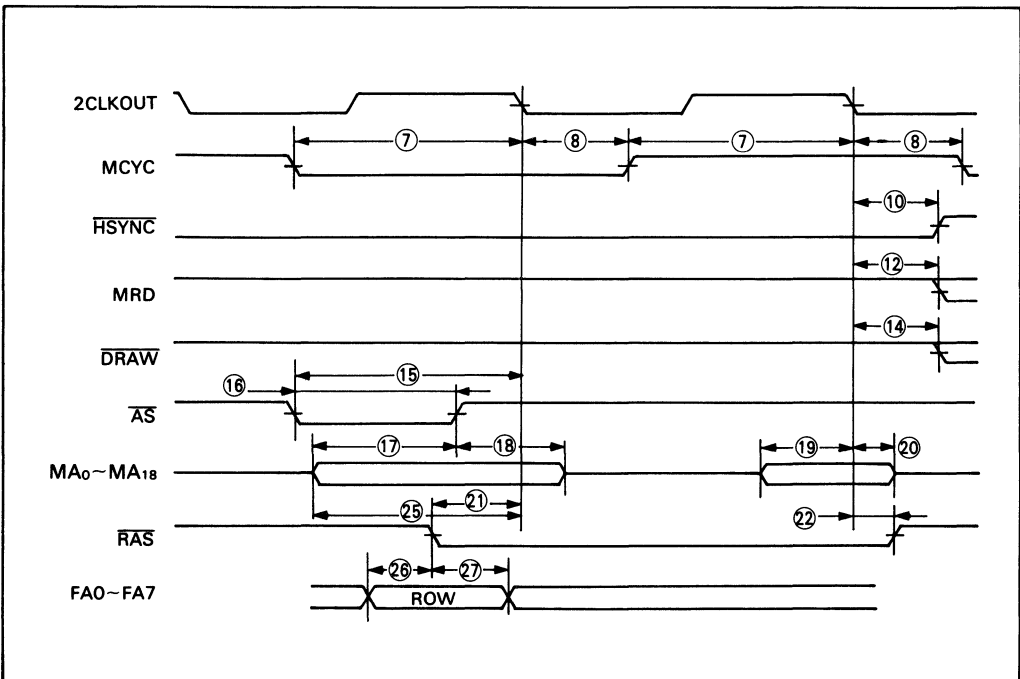

Figure 23. Attribute Cycle



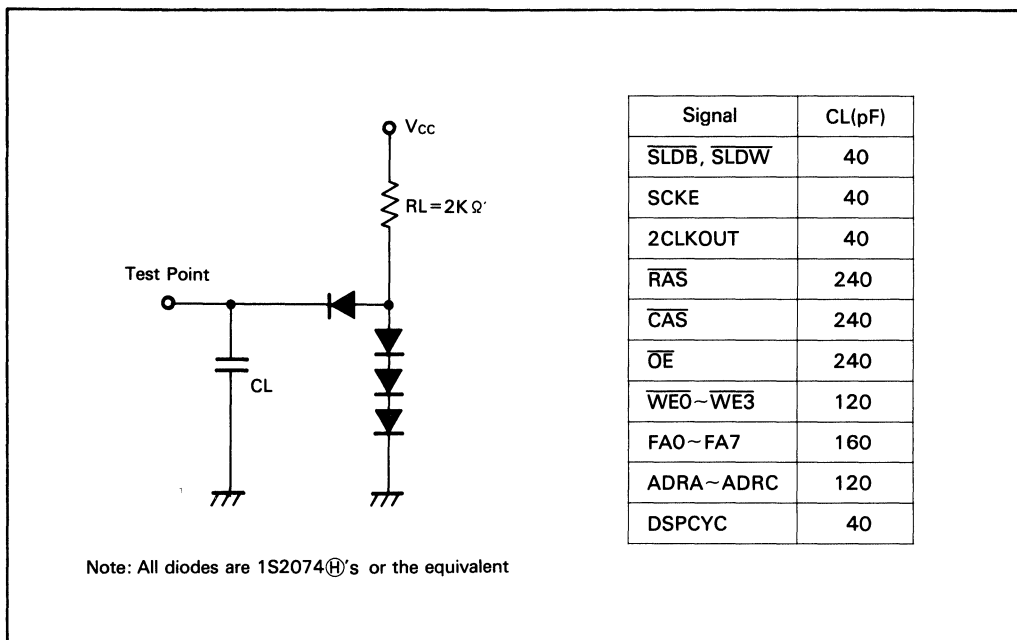

Figure 24. Test Load Circuit

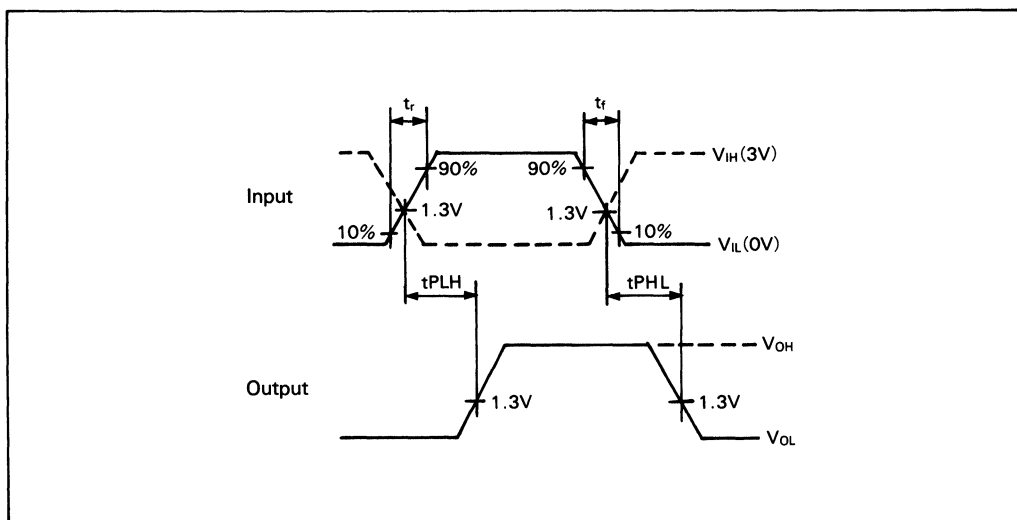
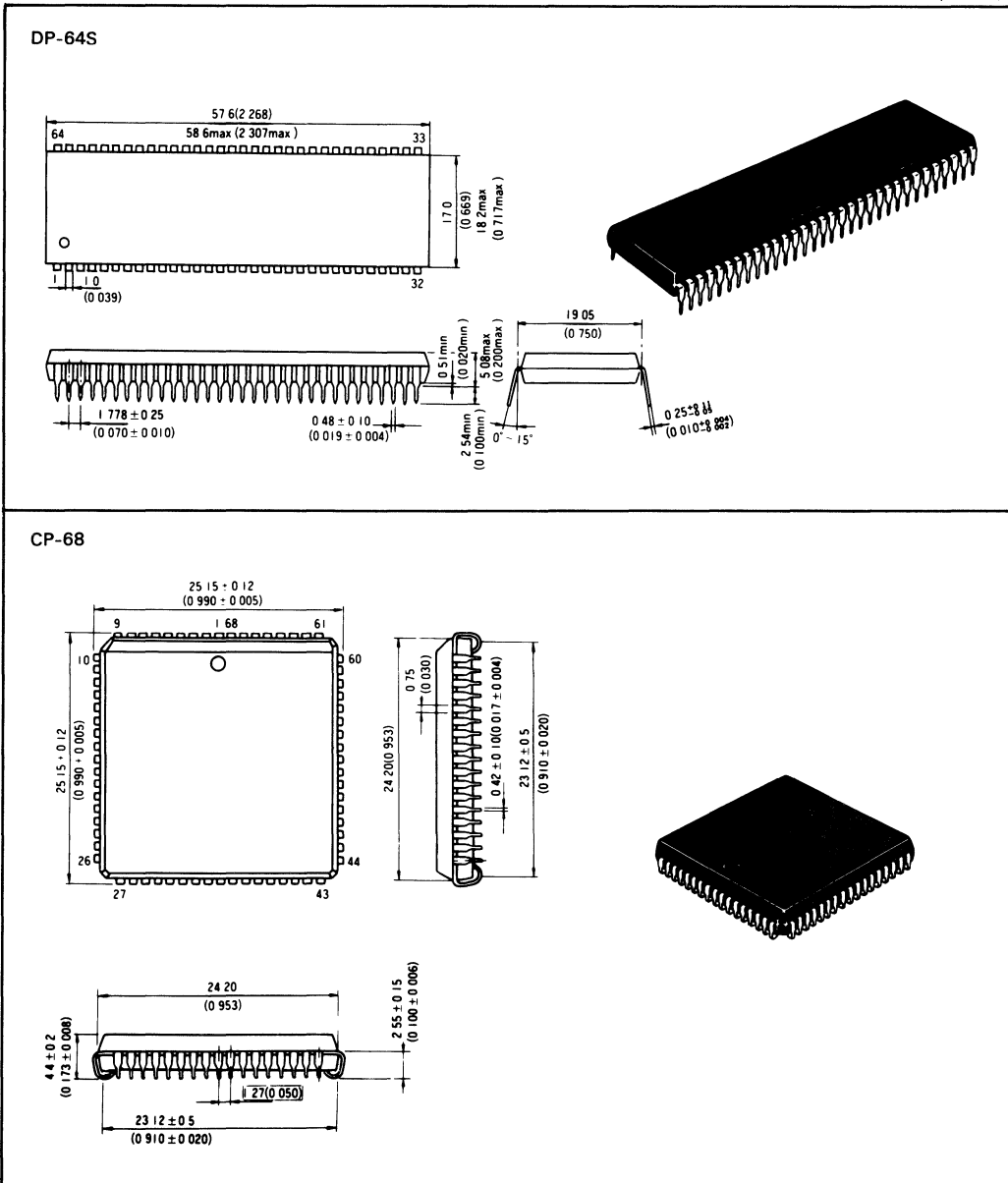

Figure 25. Input/Output waveforms



Package Dimensions

Unit: mm(inches)



Note) Inch valve indicated for your reference.



Reference Literature

Product	Data Sheet	User's Manual	Application Note	Others
HD63484 ACRTC	ID #U149	ID #U75	Introduction to ACRTC Applications, Circuits and Software ID #U90	
HD63486 GVAC	ID #U176	_____		_____