

HD74ALVCH162831

1-bit 4-bit Address Register / Driver with 3-state Outputs

REJ03D0039-0200Z
(Previous ADE-205-195(Z))
Rev.2.00
Oct.02.2003

Description

This 1-bit to 4-bit address register / driver is designed for 2.3 V to 3.6 V V_{CC} operation. The device is ideal for use in applications in which a single address bus is driving four separate memory locations. The HD74ALVCH162831 can be used as a buffer or a register, depending on the logic level of the select (\overline{SEL}) input. When \overline{SEL} is logic high, the device is in the buffer mode. The outputs follow the inputs and are controlled by the two output enable (\overline{OE}) controls. Each \overline{OE} controls two groups of nine outputs. When \overline{SEL} is logic low, the device is in the register mode. The register is an edge triggered D-type flip flop. On the positive transition of the clock (CLK) input, data set up at the A inputs is stored in the internal registers. \overline{OE} controls operate the same as in buffer mode. When \overline{OE} is logic low, the outputs are in a normal logic state (high or low logic level). When \overline{OE} is logic high, the outputs are in the high impedance state. To ensure the high impedance state during power up or power down, \overline{OE} should be tied to V_{CC} through a pullup resistor; the minimum value of the resistor is determined by the current sinking capability of the driver. \overline{SEL} and \overline{OE} do not affect the internal operation of the flip flops. Old data can be retained or new data can be entered while the outputs are in the high impedance state. Active bus hold circuitry is provided to hold unused or floating data inputs at a valid logic level. All outputs, which are designed to sink up to 12 mA, include 26 Ω resistors to reduce overshoot and undershoot.

Features

- $V_{CC} = 2.3 \text{ V to } 3.6 \text{ V}$
- Typical V_{OL} ground bounce $< 0.8 \text{ V}$ (@ $V_{CC} = 3.3 \text{ V}$, $T_a = 25^\circ\text{C}$)
- High output current $\pm 12 \text{ mA}$ (@ $V_{CC} = 3.0 \text{ V}$)
- Bus hold on data inputs eliminates the need of
- Bus hold on data inputs eliminates the need of
- All outputs have equivalent 26 Ω series resistors, so no external resistors are required.

Function Table

| Inputs | | | | Output Y |
|-----------------|------------------|-----|---|----------|
| \overline{OE} | \overline{SEL} | CLK | A | |
| H | X | X | X | Z |
| L | H | X | L | L |
| L | H | X | H | H |
| L | L | ↑ | L | L |
| L | L | ↑ | H | H |

H : High level

L : Low level

X : Immaterial

Z : High impedance

↑ : Low to high transition

**Not recommend
for new design**

Pin Arrangement

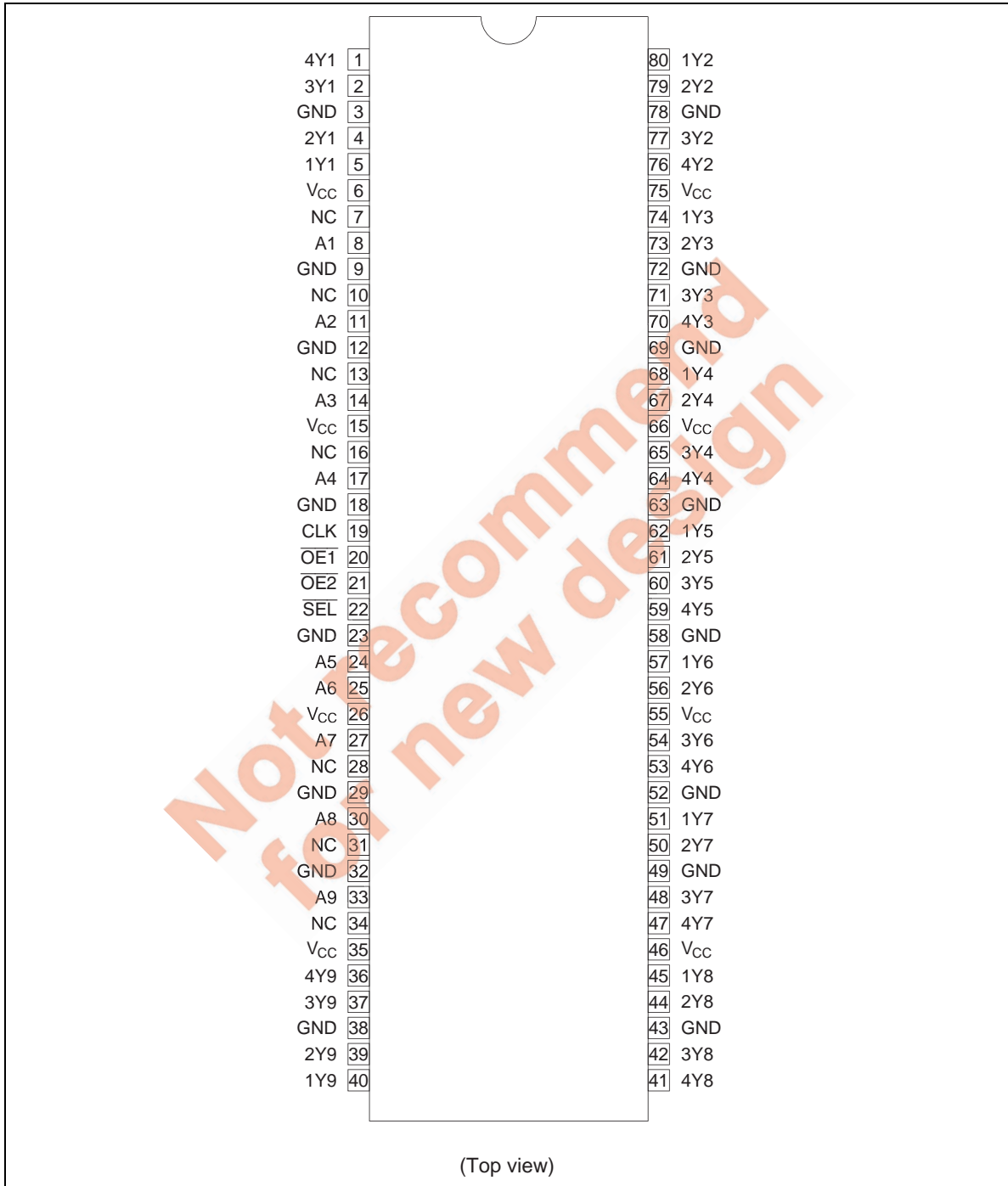

Absolute Maximum Ratings

| Item | Symbol | Ratings | Unit | Conditions |
|--|-----------------------|------------------------|------------------|-----------------------------|
| Supply voltage | V_{CC} | -0.5 to 4.6 | V | |
| Input voltage ^{*1} | V_I | -0.5 to 4.6 | V | |
| Output voltage ^{*1, 2} | V_O | -0.5 to $V_{CC} + 0.5$ | V | |
| Input clamp current | I_{IK} | -50 | mA | $V_I < 0$ |
| Output clamp current | I_{OK} | ± 50 | mA | $V_O < 0$ or $V_O > V_{CC}$ |
| Continuous output current | I_O | ± 50 | mA | $V_O = 0$ to V_{CC} |
| V_{CC} , GND current / pin | I_{CC} or I_{GND} | ± 100 | mA | |
| Maximum power dissipation at $T_a = 55^\circ\text{C}$ (in still air) ^{*3} | P_T | 1 | W | TVSOP |
| Storage temperature | T_{stg} | -65 to 150 | $^\circ\text{C}$ | |

Notes: Stresses beyond those listed under "absolute maximum ratings" may cause permanent damage to the device. These are stress ratings only, and functional operation of the device at these or any other conditions beyond those indicated under "recommended operating conditions" is not implied. Exposure to absolute maximum rated conditions for extended periods may affect device reliability.

1. The input and output negative voltage ratings may be exceeded if the input and output clamp current ratings are observed.
2. This value is limited to 4.6 V maximum.
3. The maximum package power dissipation is calculated using a junction temperature of 150°C and a board trace length of 750 mils.

Recommended Operating Conditions

| Item | Symbol | Min | Max | Unit | Conditions |
|------------------------------------|-----------------------|-----|----------|------------------|--------------------------|
| Supply voltage | V_{CC} | 2.3 | 3.6 | V | |
| Input voltage | V_I | 0 | V_{CC} | V | |
| Output voltage | V_O | 0 | V_{CC} | V | |
| High level output current | I_{OH} | — | -6 | mA | $V_{CC} = 2.3 \text{ V}$ |
| | | — | -8 | | $V_{CC} = 2.7 \text{ V}$ |
| | | — | -12 | | $V_{CC} = 3.0 \text{ V}$ |
| Low level output current | I_{OL} | — | 6 | mA | $V_{CC} = 2.3 \text{ V}$ |
| | | — | 8 | | $V_{CC} = 2.7 \text{ V}$ |
| | | — | 12 | | $V_{CC} = 3.0 \text{ V}$ |
| Input transition rise or fall rate | $\Delta t / \Delta v$ | 0 | 10 | ns / V | |
| Operating temperature | T_a | -40 | 85 | $^\circ\text{C}$ | |

Note: Unused control inputs must be held high or low to prevent them from floating.

Logic Diagram

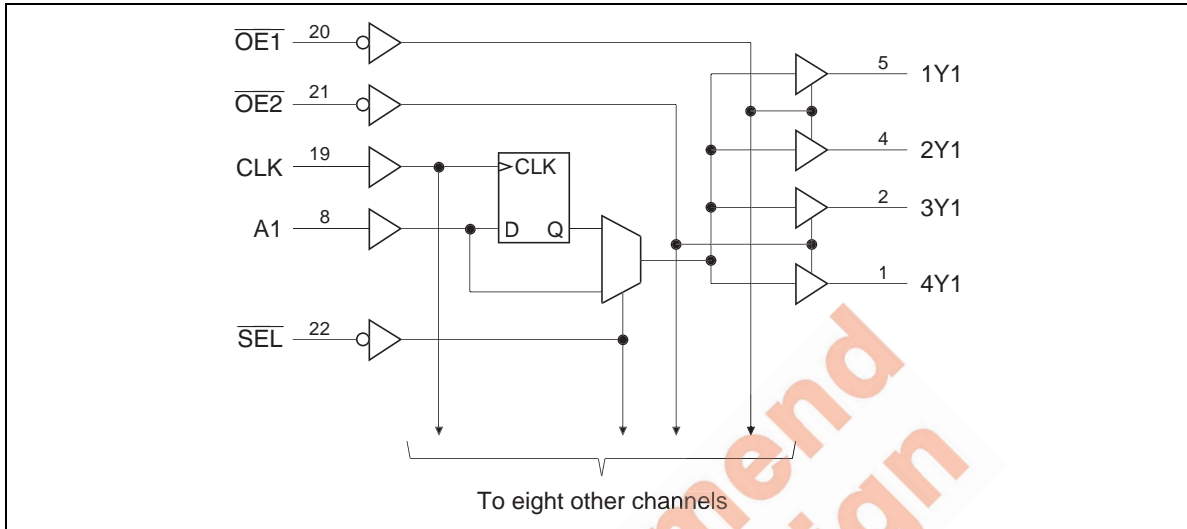

Not recommended
for new design

Electrical Characteristics

(Ta = -40 to 85°C)

| Item | Symbol | V _{CC} (V) | Min | Max | Unit | Test Conditions | | | |
|--------------------------|-----------------|---------------------|----------------------|------|--|---|---|----|---|
| Input voltage | V _{IH} | 2.3 to 2.7 | 1.7 | — | V | | | | |
| | | 2.7 to 3.6 | 2.0 | — | | | | | |
| | V _{IL} | 2.3 to 2.7 | — | 0.7 | | | | | |
| | | 2.7 to 3.6 | — | 0.8 | | | | | |
| Output voltage | V _{OH} | 2.3 to 3.6 | V _{CC} -0.2 | — | V | I _{OH} = -100 μA | | | |
| | | 2.3 | 1.9 | — | | I _{OH} = -4 mA, V _{IH} = 1.7 V | | | |
| | | 2.3 | 1.7 | — | | I _{OH} = -6 mA, V _{IH} = 1.7 V | | | |
| | | 2.7 | 2.4 | — | | I _{OH} = -6 mA, V _{IH} = 2.0 V | | | |
| | | 3.0 | 2.0 | — | | I _{OH} = -8 mA, V _{IH} = 2.0 V | | | |
| | | 3.0 | 2.0 | — | | I _{OH} = -12 mA, V _{IH} = 2.0 V | | | |
| | V _{OL} | 2.3 to 3.6 | — | 0.2 | μA | I _{OL} = 100 μA | | | |
| | | 2.3 | — | 0.4 | | I _{OL} = 4 mA, V _{IL} = 0.7 V | | | |
| | | 2.3 | — | 0.55 | | I _{OL} = 6 mA, V _{IL} = 0.7 V | | | |
| | | 3.0 | — | 0.55 | | I _{OL} = 6 mA, V _{IL} = 0.8 V | | | |
| | | 2.7 | — | 0.6 | | I _{OL} = 8 mA, V _{IL} = 0.8 V | | | |
| | | 3.0 | — | 0.8 | | I _{OL} = 12 mA, V _{IL} = 0.8 V | | | |
| | | Input current | I _{IN} | 3.6 | | — | ±5 | μA | V _{IN} = V _{CC} or GND |
| | | | | 2.3 | | 45 | — | | V _{IN} = 0.7 V |
| -45 | — | | | | V _{IN} = 1.7 V | | | | |
| 3.0 | 75 | | | — | V _{IN} = 0.8 V | | | | |
| 3.0 | -75 | | | — | V _{IN} = 2.0 V | | | | |
| 3.6 | — | | | ±500 | V _{IN} = 0 to 3.6 V ^{*1} | | | | |
| Off state output current | I _{OZ} | | | 3.6 | — | ±10 | μA | | V _{OUT} = V _{CC} or GND |
| Quiescent supply current | I _{CC} | 3.6 | — | 40 | μA | V _{IN} = V _{CC} or GND | | | |
| | | ΔI _{CC} | 3.0 to 3.6 | — | | 750 | V _{IN} = one input at (V _{CC} -0.6) V, other inputs at V _{CC} or GND | | |

Note: 1. This is the bus hold maximum dynamic current required to switch the input from one state to another.

Switching Characteristics

(T_a = -40 to 85°C)

| Item | Symbol | V _{CC} (V) | Min | Typ | Max | Unit | FROM (Input) | TO (Output) | | |
|-------------------------|------------------|---------------------|---------|---------|-----|------|----------------|-------------|-----|---|
| Maximum clock frequency | f _{max} | 2.5±0.2 | 150 | — | — | MHz | | | | |
| | | 2.7 | 150 | — | — | | | | | |
| | | 3.3±0.3 | 150 | — | — | | | | | |
| Propagation delay time | t _{PLH} | 2.5±0.2 | 1.1 | — | 4.7 | ns | A | Y | | |
| | | 2.7 | — | — | 4.8 | | | | | |
| | t _{PHL} | 3.3±0.3 | 1.5 | — | 4.3 | | | | | |
| | | 2.5±0.2 | 1.0 | — | 5.3 | | | | CLK | Y |
| | | | 2.7 | — | — | 5.3 | | | | |
| | | | 3.3±0.3 | 1.4 | — | 4.7 | | | | |
| | | | | 2.5±0.2 | 1.1 | — | 6.0 | | SEL | Y |
| | | | | 2.7 | — | — | 6.2 | | | |
| | | | 3.3±0.3 | 1.5 | — | 4.8 | | | | |
| | | | | | | | | | | |
| Output enable time | t _{ZH} | 2.5±0.2 | 1.0 | — | 5.9 | ns | OE | Y | | |
| | | 2.7 | — | — | 5.9 | | | | | |
| | t _{ZL} | 3.3±0.3 | 1.1 | — | 5.1 | | | | | |
| Output disable time | t _{HZ} | 2.5±0.2 | 1.4 | — | 6.3 | ns | OE | Y | | |
| | | 2.7 | — | — | 5.4 | | | | | |
| | t _{LZ} | 3.3±0.3 | 1.6 | — | 5.1 | | | | | |
| Setup time | t _{su} | 2.5±0.2 | 2.0 | — | — | ns | | | | |
| | | 2.7 | 2.0 | — | — | | | | | |
| | | 3.3±0.3 | 1.6 | — | — | | | | | |
| Hold time | t _h | 2.5±0.2 | 0.7 | — | — | ns | | | | |
| | | 2.7 | 0.5 | — | — | | | | | |
| | | 3.3±0.3 | 1.1 | — | — | | | | | |
| Pulse width | t _w | 2.5±0.2 | 3.3 | — | — | ns | | | | |
| | | 2.7 | 3.3 | — | — | | | | | |
| | | 3.3±0.3 | 3.3 | — | — | | | | | |
| Input capacitance | C _{IN} | 3.3 | — | 4.5 | — | pF | Control inputs | | | |
| | | 3.3 | — | 5.0 | — | | Data inputs | | | |
| Output capacitance | C _O | 3.3 | — | 7.5 | — | pF | | | | |

Switching Characteristics

(Ta = 0 to 65°C)

| Item | Symbol | V _{CC} (V) | Min | Typ | Max | Unit | FROM (Input) | TO (Output) |
|------------------------|-------------------------------------|---------------------|-----|-----|-----|------|-----------------|----------------|
| Propagation delay time | t _{PLH} , t _{PHL} | 3.3±0.15 | 1.9 | — | 4.5 | ns | CLK | Y |

Not recommend
for new design

Test Circuit

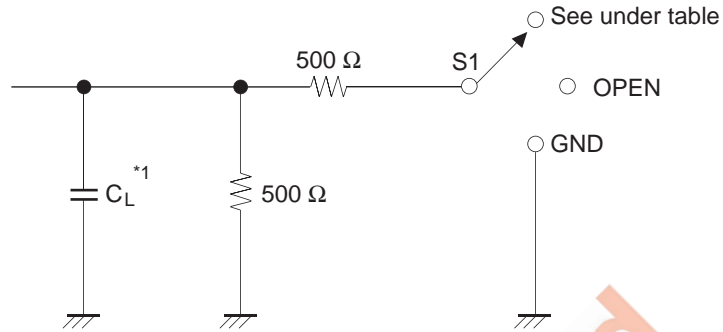

Load Circuit for Outputs

| Symbol | V _{CC} =2.5±0.2V | V _{CC} =2.7V, 3.3±0.3V |
|---|---------------------------|------------------------------------|
| t _{PLH} /t _{PHL} | OPEN | OPEN |
| t _{su} /t _h /t _w | OPEN | OPEN |
| t _{ZH} /t _{HZ} | GND | GND |
| t _{ZL} /t _{LZ} | 2 × V _{CC} | 6.0 V |
| C _L | 30 pF | 50 pF |

Note: 1. C_L includes probe and jig capacitance.

Not recommended for new design

Waveforms - 1

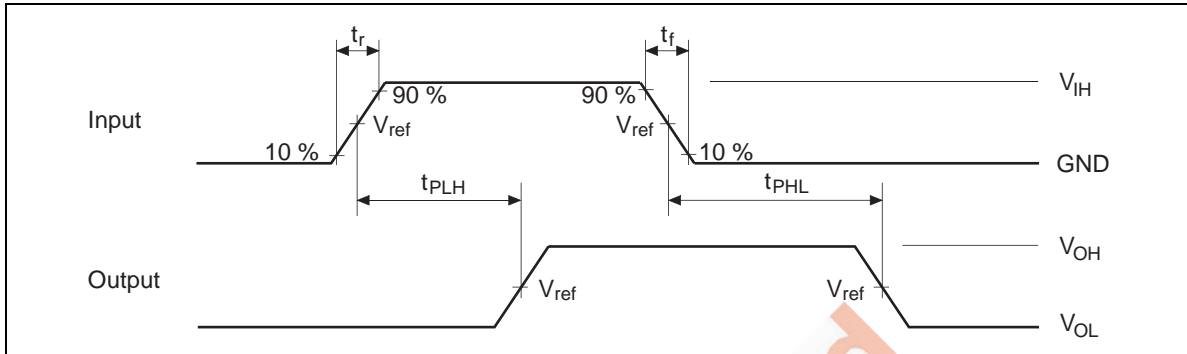

Waveforms - 2

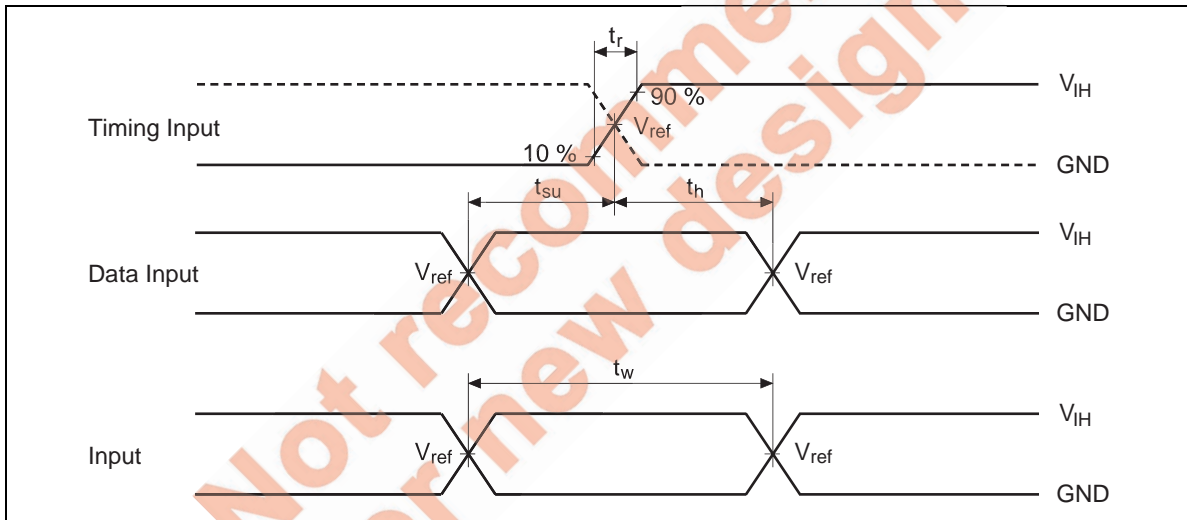

Waveforms - 3

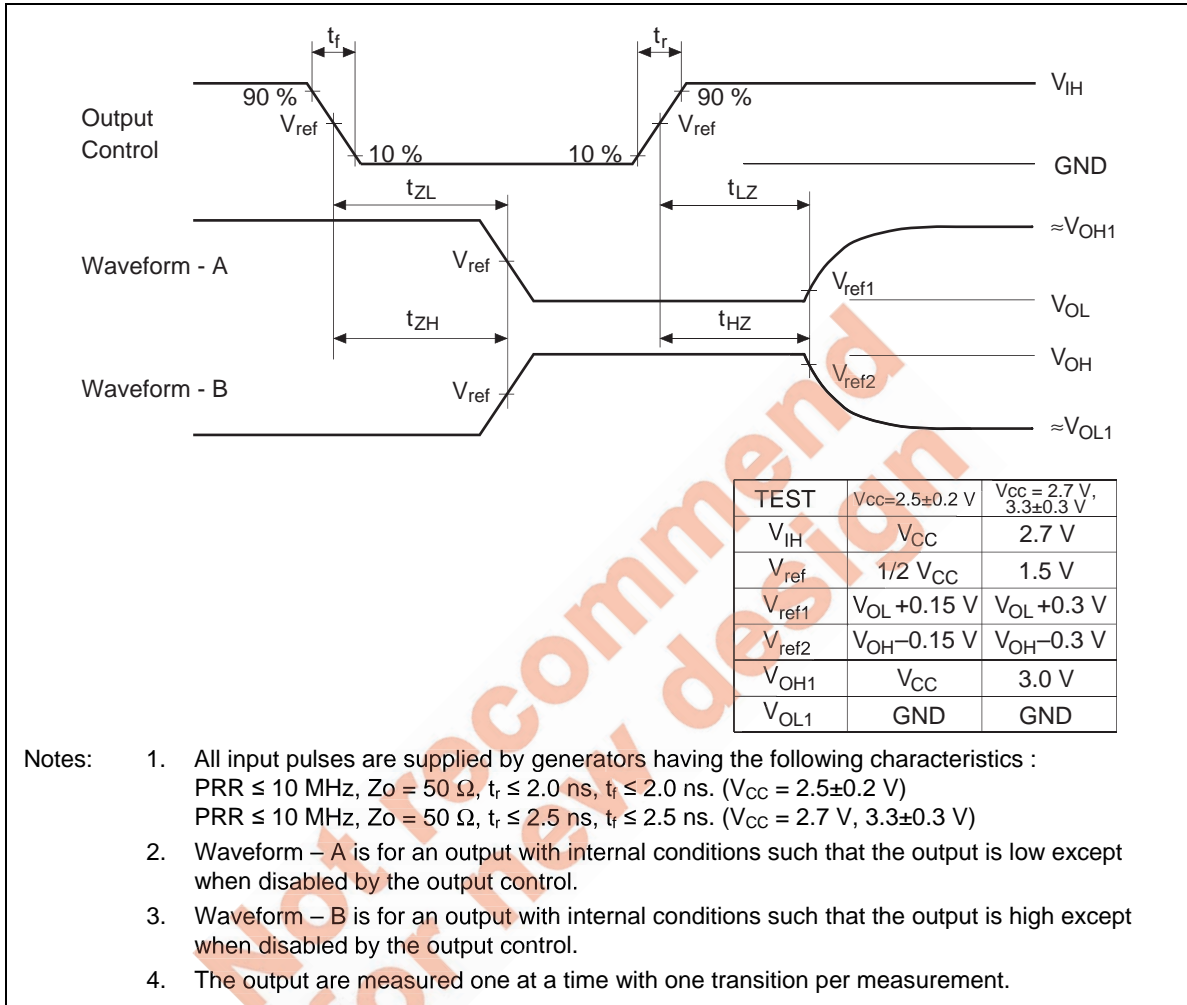

Package Dimensions

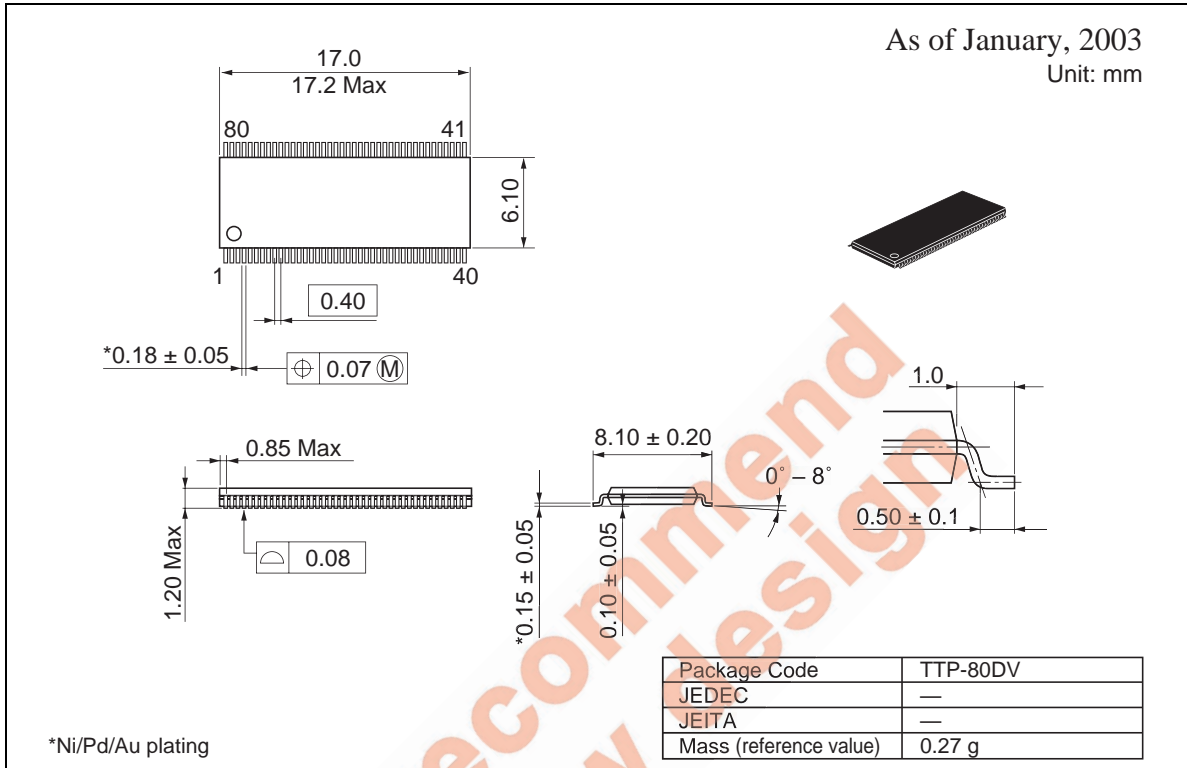

Renesas Technology Corp. Sales Strategic Planning Div. Nippon Bldg., 2-6-2, Ohte-machi, Chiyoda-ku, Tokyo 100-0004, Japan

Keep safety first in your circuit designs!

1. Renesas Technology Corp. puts the maximum effort into making semiconductor products better and more reliable, but there is always the possibility that trouble may occur with them. Trouble with semiconductors may lead to personal injury, fire or property damage.
Remember to give due consideration to safety when making your circuit designs, with appropriate measures such as (i) placement of substitutive, auxiliary circuits, (ii) use of nonflammable material or (iii) prevention against any malfunction or mishap.

Notes regarding these materials

1. These materials are intended as a reference to assist our customers in the selection of the Renesas Technology Corp. product best suited to the customer's application; they do not convey any license under any intellectual property rights, or any other rights, belonging to Renesas Technology Corp. or a third party.
2. Renesas Technology Corp. assumes no responsibility for any damage, or infringement of any third-party's rights, originating in the use of any product data, diagrams, charts, programs, algorithms, or circuit application examples contained in these materials.
3. All information contained in these materials, including product data, diagrams, charts, programs and algorithms represents information on products at the time of publication of these materials, and are subject to change by Renesas Technology Corp. without notice due to product improvements or other reasons. It is therefore recommended that customers contact Renesas Technology Corp. or an authorized Renesas Technology Corp. product distributor for the latest product information before purchasing a product listed herein.
The information described here may contain technical inaccuracies or typographical errors.
Renesas Technology Corp. assumes no responsibility for any damage, liability, or other loss rising from these inaccuracies or errors.
Please also pay attention to information published by Renesas Technology Corp. by various means, including the Renesas Technology Corp. Semiconductor home page (<http://www.renesas.com>).
4. When using any or all of the information contained in these materials, including product data, diagrams, charts, programs, and algorithms, please be sure to evaluate all information as a total system before making a final decision on the applicability of the information and products. Renesas Technology Corp. assumes no responsibility for any damage, liability or other loss resulting from the information contained herein.
5. Renesas Technology Corp. semiconductors are not designed or manufactured for use in a device or system that is used under circumstances in which human life is potentially at stake. Please contact Renesas Technology Corp. or an authorized Renesas Technology Corp. product distributor when considering the use of a product contained herein for any specific purposes, such as apparatus or systems for transportation, vehicular, medical, aerospace, nuclear, or undersea repeater use.
6. The prior written approval of Renesas Technology Corp. is necessary to reprint or reproduce in whole or in part these materials.
7. If these products or technologies are subject to the Japanese export control restrictions, they must be exported under a license from the Japanese government and cannot be imported into a country other than the approved destination.
Any diversion or reexport contrary to the export control laws and regulations of Japan and/or the country of destination is prohibited.
8. Please contact Renesas Technology Corp. for further details on these materials or the products contained therein.



RENESAS SALES OFFICES

<http://www.renesas.com>

Renesas Technology America, Inc.
450 Holger Way, San Jose, CA 95134-1368, U.S.A
Tel: <1> (408) 382-7500 Fax: <1> (408) 382-7501

Renesas Technology Europe Limited.
Dukes Meadow, Millboard Road, Bourne End, Buckinghamshire, SL8 5FH, United Kingdom
Tel: <44> (1628) 585 100, Fax: <44> (1628) 585 900

Renesas Technology Europe GmbH
Dornacher Str. 3, D-85622 Feldkirchen, Germany
Tel: <49> (89) 380 70 0, Fax: <49> (89) 929 30 11

Renesas Technology Hong Kong Ltd.
7/F., North Tower, World Finance Centre, Harbour City, Canton Road, Hong Kong
Tel: <852> 2265-6688, Fax: <852> 2375-6836

Renesas Technology Taiwan Co., Ltd.
FL 10, #99, Fu-Hsing N. Rd., Taipei, Taiwan
Tel: <886> (2) 2715-2888, Fax: <886> (2) 2713-2999

Renesas Technology (Shanghai) Co., Ltd.
26/F., Ruijin Building, No.205 Maoming Road (S), Shanghai 200020, China
Tel: <86> (21) 6472-1001, Fax: <86> (21) 6415-2952

Renesas Technology Singapore Pte. Ltd.
1, Harbour Front Avenue, #06-10, Keppel Bay Tower, Singapore 098632
Tel: <65> 6213-0200, Fax: <65> 6278-8001