



# HD8205

## Dual N-Channel Enhancement Mode MOSFET

Product Summary		
V <sub>DS</sub> (V)	I <sub>D</sub> (A)	R <sub>DS(ON)</sub> (mΩ) Max
20V	5A	29 @V <sub>GS</sub> = 4.5V
		34 @V <sub>GS</sub> = 2.5V

### FEATURES

- Super high dense cell design for low R<sub>DS(ON)</sub>.
- Rugged and reliable.
- Surface Mount package.

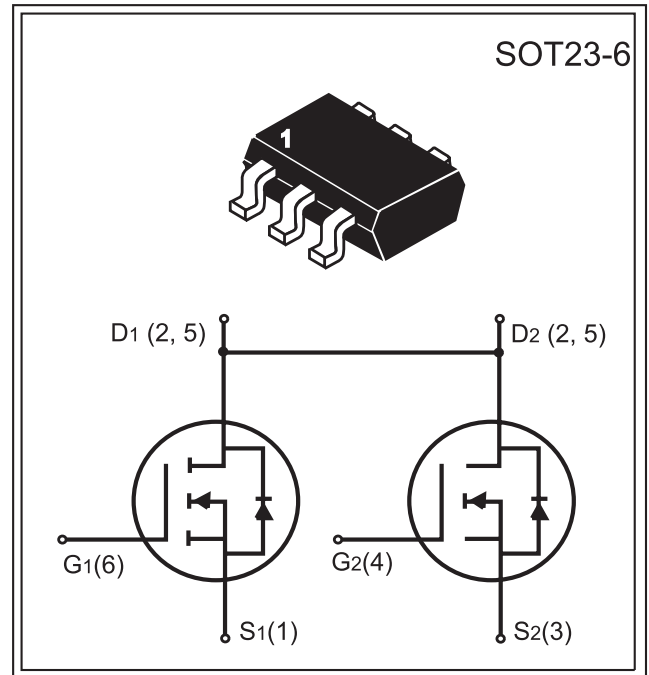

ABSOLUTE MAXIMUM RATINGS (T <sub>A</sub> = 25°C unless otherwise noted)			
Parameter	Symbol	Limit	Unit
Drain-Source Voltage	V <sub>DS</sub>	20	V
Gate-Source Voltage	V <sub>GS</sub>	±12	V
Drain Current-Continuous @ T <sub>J</sub> = 25°C	I <sub>D</sub>	5	A
-Pulsed <sup>b</sup>	I <sub>DM</sub>	20	A
Drain-Source Diode Forward Current <sup>a</sup>	I <sub>S</sub>	2.5	A
Maximum Power Dissipation <sup>a</sup>	P <sub>D</sub>	1.25	W
Operating Junction and Storage Temperature Range	T <sub>J</sub> , T <sub>STG</sub>	-55 to 150	°C
THERMAL CHARACTERISTICS			
Thermal Resistance, Junction-to-Ambient <sup>a</sup>	R <sub>JA</sub>	100	°C/W



Electrical Characteristics (T <sub>A</sub> = 25°C unless otherwise noted)						
Parameter	Symbol	Condition	Min	Typ <sup>c</sup>	Max	Unit
Drain-Source Breakdown Voltage	BV <sub>DSS</sub>	V <sub>GS</sub> =0V, I <sub>D</sub> =250nA	20			V
Zero Gate Voltage Drain Current	I <sub>DSS</sub>	V <sub>DS</sub> =16V, V <sub>GS</sub> =0V			1	μA
Gate-Body Leakage	I <sub>GSS</sub>	V <sub>GS</sub> =10V, V <sub>DS</sub> =0V			100	nA
Gate Threshold Voltage	V <sub>GS(th)</sub>	V <sub>DS</sub> =V <sub>GS</sub> I <sub>D</sub> =250nA	0.4		1.0	V
Drain-Source On-State Resistance	R <sub>DS(ON)</sub>	V <sub>GS</sub> =4.5V, I <sub>D</sub> =4.5A		20	29	mΩ
		V <sub>GS</sub> =2.5V, I <sub>D</sub> =3.5A		27	34	
Forward Transconductance	g <sub>FS</sub>	V <sub>DS</sub> =5V, I <sub>D</sub> =7A		17.7		S
Input Capacitance	C <sub>ISS</sub>	V <sub>DS</sub> =8V V <sub>GS</sub> =0V f=1.0MHz		802		pF
Output Capacitance	C <sub>OSS</sub>			153		
Reverse Transfer Capacitance	C <sub>RSS</sub>			122		
Turn-On Delay Time	t <sub>D(ON)</sub>	V <sub>D</sub> =10V, I <sub>D</sub> =1A, V <sub>GEN</sub> =4.5V, R <sub>GEN</sub> =10Ω, R <sub>L</sub> =10Ω		18		ns
Rise Time	t <sub>r</sub>			5		
Turn-Off Delay Time	t <sub>D(OFF)</sub>			43.8		
Fall Time	t <sub>f</sub>			20		
Total Gate Charge	Q <sub>g</sub>	V <sub>DS</sub> =10V, I <sub>D</sub> =4A, V <sub>GS</sub> =4.5V		10.5		nC
Gate-Source Charge	Q <sub>gs</sub>			2		
Gate-Drain Charge	Q <sub>gd</sub>			2.5		
Diode Forward Voltage	V <sub>SD</sub>	V <sub>GS</sub> =0V, I <sub>D</sub> =1A			1.2	V

Notes:

- Surface Mounted on FR4 Board, t ≤ 10 sec.
- Pulse Test: Pulse Width ≤ 300 μs, Duty Cycle ≤ 2%.
- Guaranteed by design, not subject to production testing.

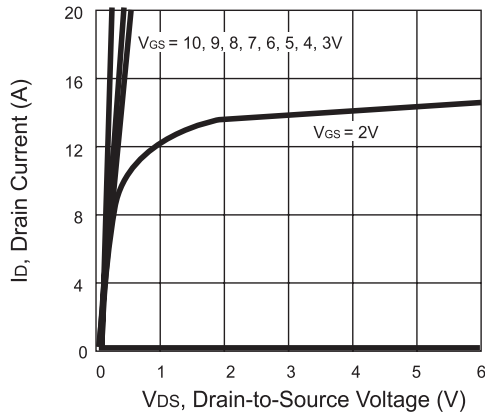

Figure 1. Output Characteristics

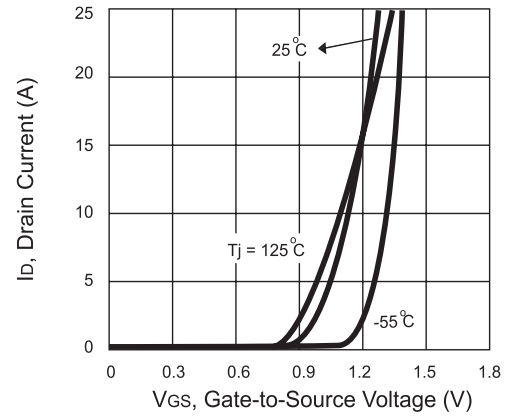

Figure 2. Transfer Characteristics

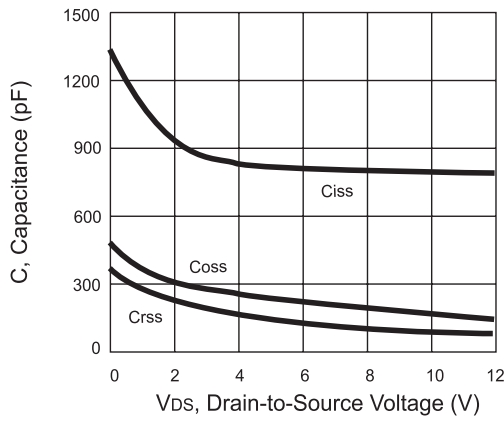

Figure 3. Capacitance

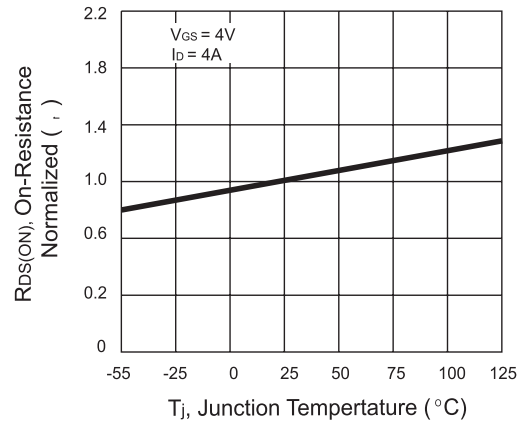

Figure 4. On-Resistance Variation with Temperature

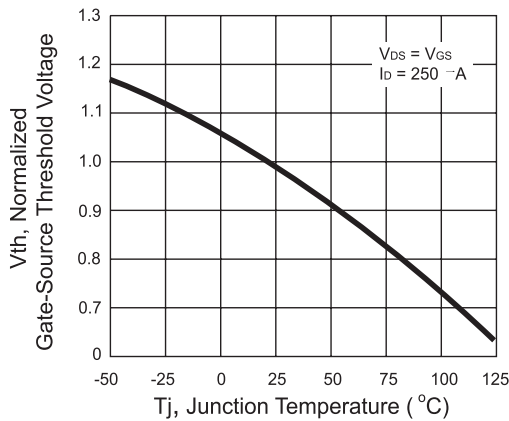

Figure 5. Gate Threshold Variation with Temperature

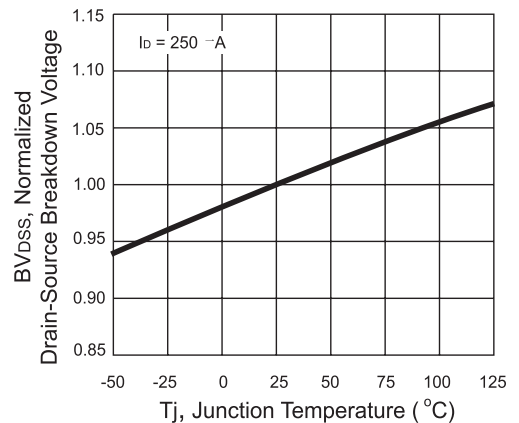

Figure 6. Breakdown Voltage Variation with Temperature

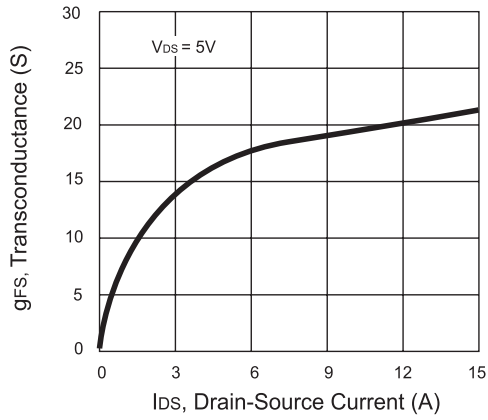

Figure 7. Transconductance Variation with Drain Current

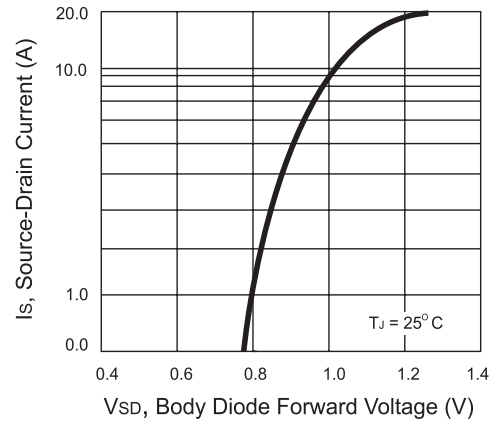

Figure 8. Body Diode Forward Voltage Variation with Source Current

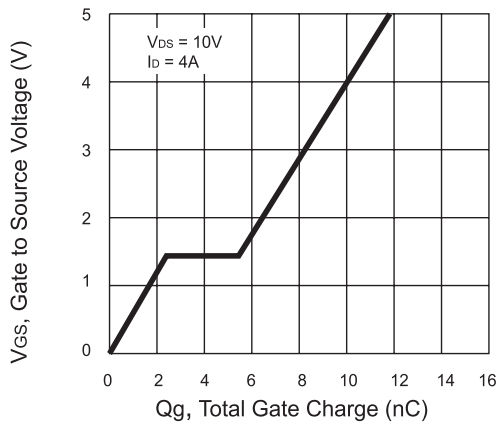

Figure 9. Gate Charge

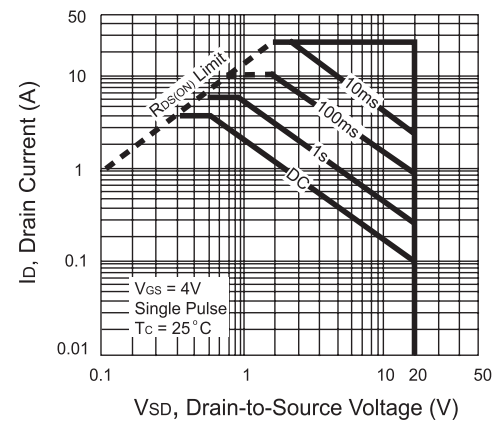

Figure 10. Maximum Safe Operating Area

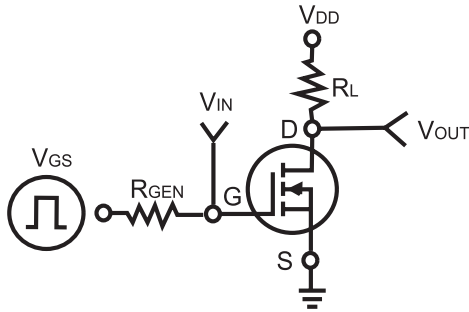

Figure 11. Switching Test Circuit

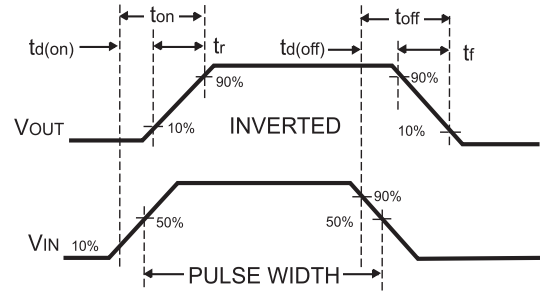

Figure 12. Switching Waveforms

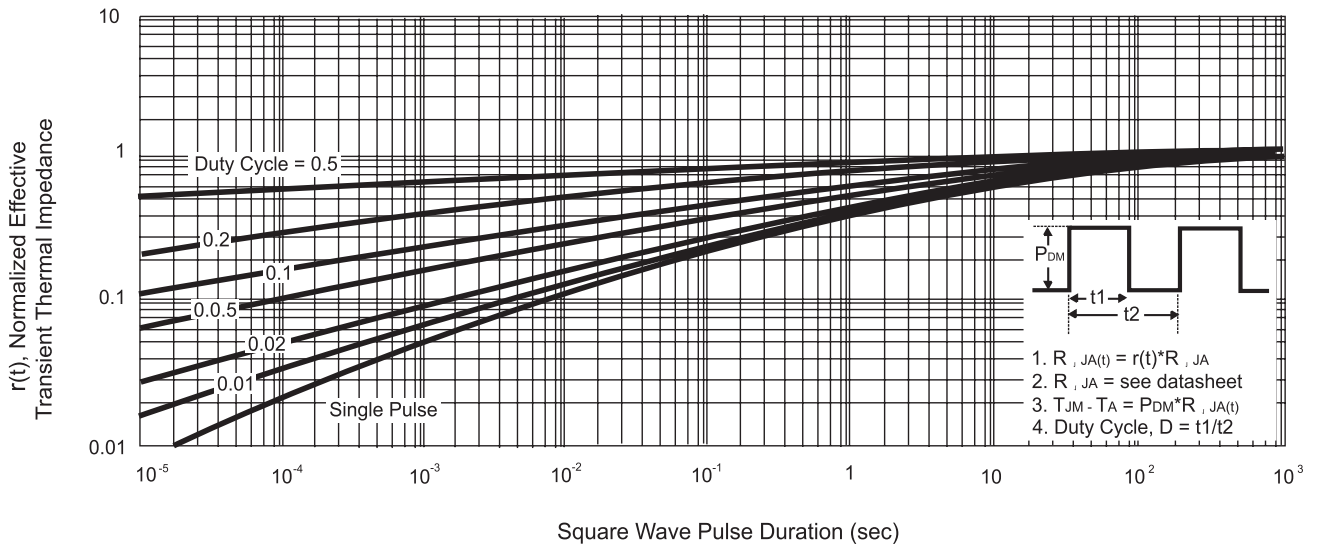
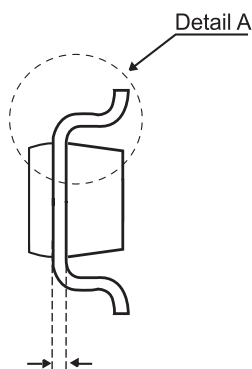
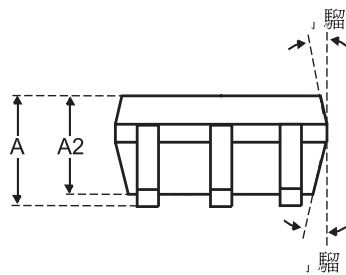
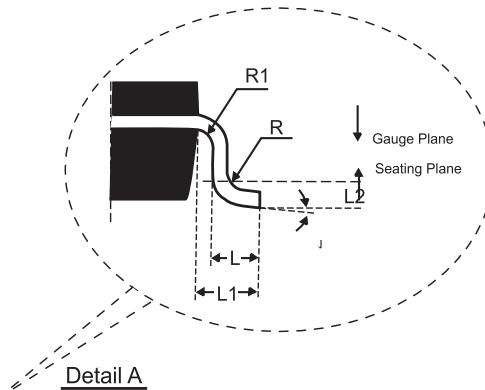
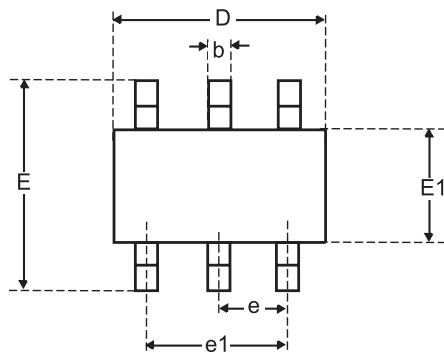

Figure 13. Normalized Thermal Transient Impedance Curve

### Package Outline Dimensions

SOT23-6



SYMBOLS	MILLIMETERS		
	Min.	Nom.	Max.
A	駢	駢	1.45
A2	0.90	0.15	1.30
b	0.30	駢	0.50
c	0.08	駢	0.22
D	2.70	2.90	3.10
E	2.50	2.80	3.10
E1	1.50	1.60	1.70
e	0.95 BSC		
e1	1.90 BSC		
L	0.30	0.45	0.60
L1	0.60 BSC		
L2	0.20 BSC		
R	0.10	駢	駢
R1	0.10	駢	0.25
j	0°	4°	8°
j1	0°	10°	15°

### Carrier Tape & Reel Dimensions

SOT23-6

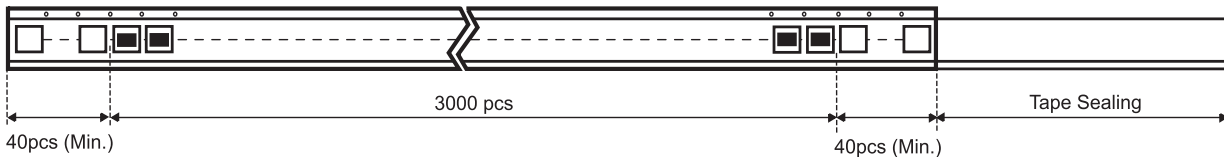
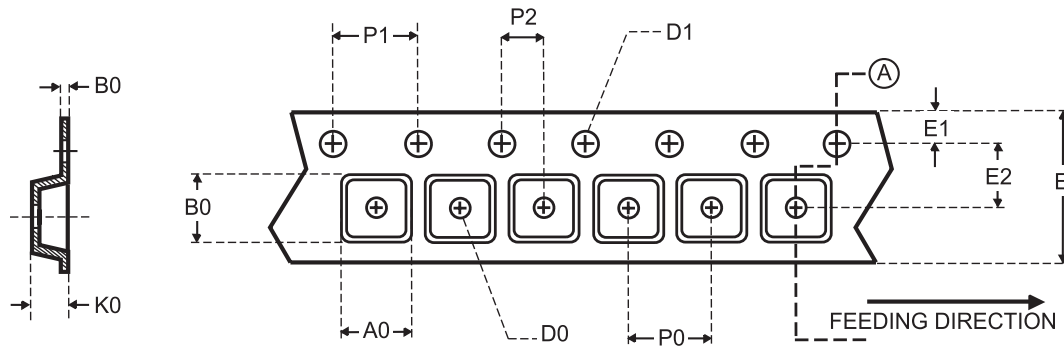

	A0	B0	K0	D0	D1	E	E1	E2	P0	P1	P2	
SOT23-6	3.15	3.20	1.40	$\begin{matrix} \text{L} 1.50 \\ +0.10 \\ -0.00 \end{matrix}$	$\begin{matrix} \text{L} 1.50 \\ +0.10 \\ -0.00 \end{matrix}$	$\begin{matrix} 8.00 \\ \pm 0.30 \end{matrix}$	1.75	$\begin{matrix} 3.50 \\ \pm 0.05 \end{matrix}$	4.00	4.00	$\begin{matrix} 2.00 \\ \pm 0.05 \end{matrix}$	$\begin{matrix} 0.20 \\ \pm 0.03 \end{matrix}$

UNIT: mm

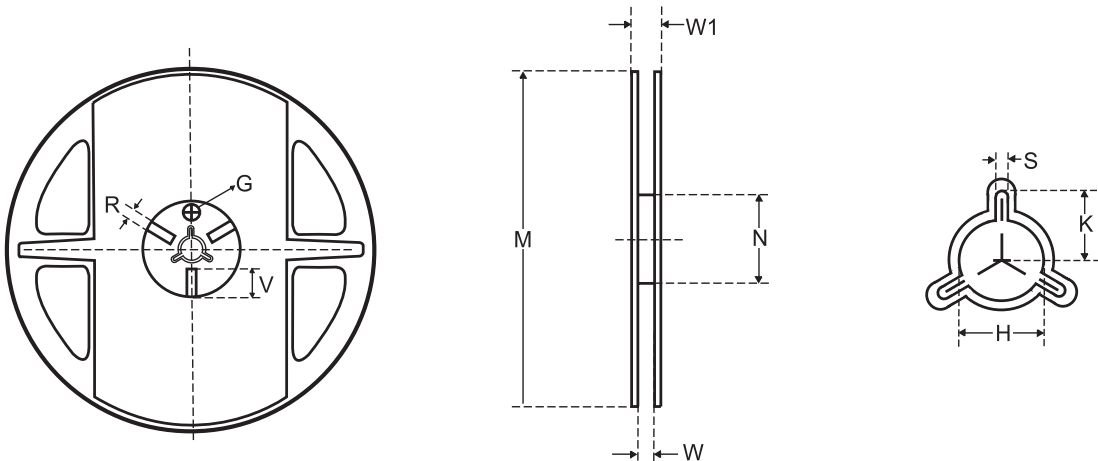

Tape size	Reel Size	M	N	W	W1	H	K	S	G	R	V
8mm	$\begin{matrix} \text{L} 178 \end{matrix}$	$\begin{matrix} \text{L} 178 \\ \pm 1 \end{matrix}$	$\begin{matrix} \text{L} 60 \\ \pm 1 \end{matrix}$	$\begin{matrix} 8.4 \\ \pm 0.5 \end{matrix}$	$\begin{matrix} 11.4 \\ -0.5 \end{matrix}$	$\begin{matrix} \text{L} 13.5 \\ \pm 0.5 \end{matrix}$	10.5	$\begin{matrix} 2.0 \\ \pm 0.5 \end{matrix}$	$\begin{matrix} \text{L} 10.0 \end{matrix}$	5.0	18.0

UNIT: mm