

Approved by:

Checked by:

Issued by:

SPECIFICATION

PRODUCT: SAW FILTER

MODEL: HDBF36A2D



SHOULDER ELECTRONICS LIMITED

1.SCOPE

SHOULDER's SAW filter series have broad line up products meeting all broadcast standard including NTSC,PAL and SECAM systems. These filters are composed of two interdigital transducers on a single-crystal. piezoelectrical chip. they are used in electronic equipments such as TV and so on.

2.Construction

2.1 Dimension and materials

Manufacturer's name : SHOULDER ELECTRONICS Co. LTD(CHINA)

Type : BF36A2D

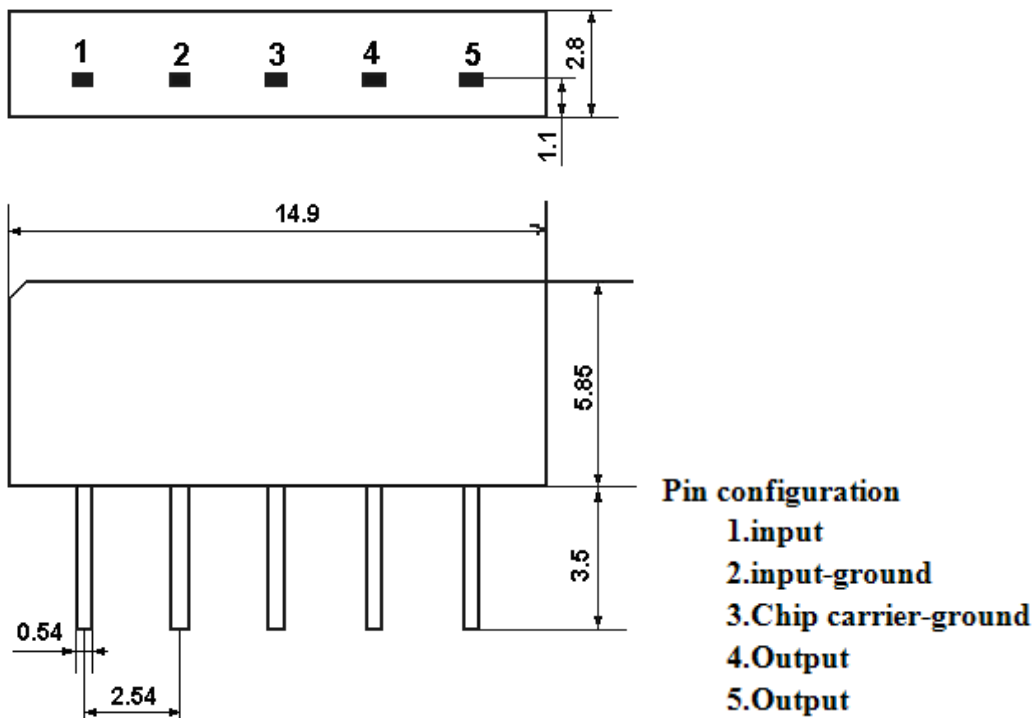

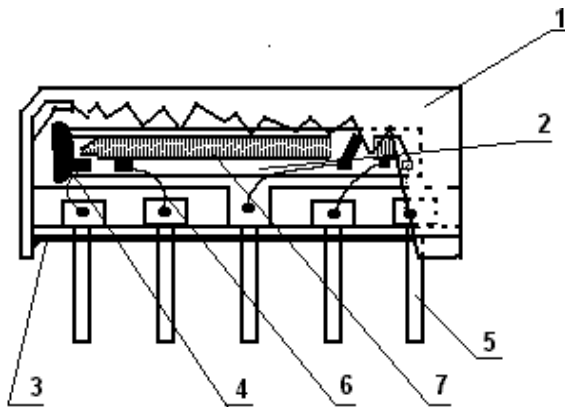

Components	Materials
1.Outer casing	PPS
2.Substrate	Lithium niobate
3.Base	Epoxy resin
4.Absorber	Epoxy resin
5.Lead	Cu alloy+Au plate
6.Bonding wire	AlSi alloy
7.Electrode	Al

2.2. Circuit construction, measurement circuit

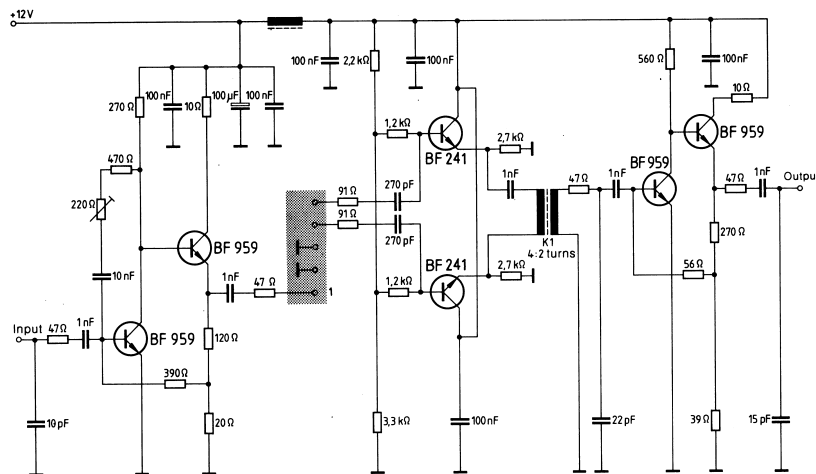

Test circuit for SIP-5 filter
Input impedance of the symmetrical post-amplifier: 2 kΩ in parallel with 3 pF

3.Characteristics

Items	Conditions	Specifications
-------	------------	----------------

Standard atmospheric conditions	Unless otherwise specified , the standard rang of atmospheric conditions for making measurements and tests is as follows; Ambient temperature : 15°C to 35°C Relative humidity : 25% to 85% Air pressure : 86kPa to 106kPa	There shall be no damage.
Operating temperature rang	Operating temperature rang is the rang of ambient temperatures in which the filter can be operated continuously. -10°C ~ +60°C	
Storage temperature rang	Storage temperature rang is the rang of ambient temperatures at which the filter can be stored without damage. Conditions are as specified elsewhere in these specifications. -40°C ~ +70°C	
Reference temperature	+25°C	

3.1 Maximum Rating

DC voltage VDC	12	V	Between any terminals
AC voltage Vpp	10	V	Between any terminals

3.2 Electrical Characteristics

Source impedance

$$Z_s=50\Omega$$

Load impedance

$$Z_L=2k\Omega//3pF$$

$$T_A=25^\circ C$$

Item	Freq	min	typ	max	
Center frequency	Fo	-	36.00	-	MHz
Insertion attenuation Reference level	36.00MHz	19.0	21.0	23.0	dB
Amplitude ripple (p-p) 32,35 ... 39,65 MHz		-	0.7	1.2	dB
Pass bandwidth	B _{1.5dB}	-	7.8	-	MHz
	B _{3dB}	-	8.1	-	MHz

	B_{15dB}	-	8.9	-	MHz
	B_{30dB}	-	9.4	-	MHz
Relative attenuation	31.65MHz	7.0	10.0	-	dB
	40.35MHz	7.0	10.0	-	dB
	31.30MHz	22.0	29.0	-	dB
	40.70MHz	22.0	29.0	-	dB
Reflected wave signal suppression 1,0 μ s ... 6,0 μ s after main pulse (test pulse 250 ns, carrier frequency 36,00 MHz)		42.0	52.0	-	dB
Feedthrough signal suppression 1,3 μ s ... 1,2 μ s before main pulse (test pulse 250 ns, carrier frequency 36,00 MHz)		-	50.0	-	dB
Group delay ripple (p-p) $\Delta\tau$ 32,35 ... 39,65 MHz			50	80	ns
Impedance at 36,00 MHz Input: $Z_{IN} = R_{IN} \parallel C_{IN}$ Output: $Z_{OUT} = R_{OUT} \parallel C_{OUT}$		-	2,8 15,5 2,4 4,4	-	k Ω pF k Ω pF
Sidelobe	25.00~31.00MHz	32.0	40.0	-	dB
	41.00~45.00MHz	30.0	38.0	-	dB
Temperature coefficient			-72		ppm/k

3.3 Environmental Performance Characteristics

Item	Condition	Specifications
High temperature	The specimen shall be store at a temperature of $80\pm 2^{\circ}\text{C}$ for $96\pm 4\text{h}$. Then it shall be subjected to standard atmospheric conditions for 1h, after which measurement shall be made within 1h.	Mechanical characteristics and specifications in electrical characteristics shall be satisfied. There shall be no excessive change in appearance.
Low temperature	The specimen shall be store at a temperature of $-20\pm 3^{\circ}\text{C}$ for $96\pm 4\text{h}$. Then it shall be subjected to standard atmospheric conditions for 1h, after which measurement shall be made within 1h.	
Humidity	The specimen shall be store at a temperature of $40\pm 2^{\circ}\text{C}$ with relative humidity of 90% to 96% for $96\pm 4\text{h}$. Then it shall be subjected to standard atmospheric conditions for 1h, after which measurement shall be made within 1h.	
Thermal shock	The specimen shall be subjected to 8 continuous cycles each as shown below. Then it shall be subjected to standard atmospheric conditions for 1h, after which measurement shall be made	

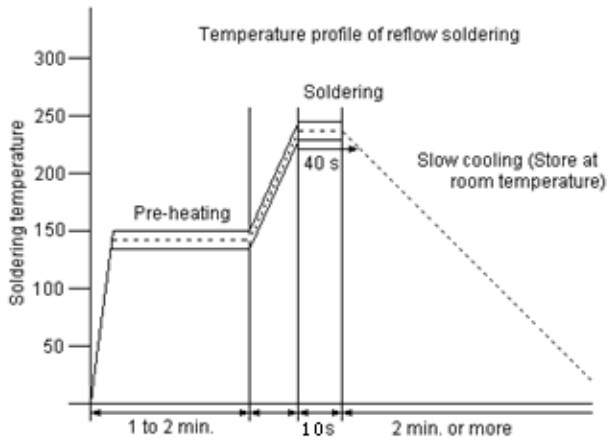
	<p>within 1h.</p> <table border="1"> <thead> <tr> <th></th> <th>Temperature</th> <th>Duration</th> </tr> </thead> <tbody> <tr> <td>1</td> <td>+25 °C=>-40 °C</td> <td>0.5h</td> </tr> <tr> <td>2</td> <td>-40 °C</td> <td>4h</td> </tr> <tr> <td>3</td> <td>-40 °C=>+85 °C</td> <td>2h</td> </tr> <tr> <td>4</td> <td>+85 °C</td> <td>4h</td> </tr> <tr> <td>5</td> <td>+85 °C=>+25 °C</td> <td>0.5h</td> </tr> <tr> <td>6</td> <td>+25 °C</td> <td>1h</td> </tr> </tbody> </table>		Temperature	Duration	1	+25 °C=>-40 °C	0.5h	2	-40 °C	4h	3	-40 °C=>+85 °C	2h	4	+85 °C	4h	5	+85 °C=>+25 °C	0.5h	6	+25 °C	1h	
	Temperature	Duration																					
1	+25 °C=>-40 °C	0.5h																					
2	-40 °C	4h																					
3	-40 °C=>+85 °C	2h																					
4	+85 °C	4h																					
5	+85 °C=>+25 °C	0.5h																					
6	+25 °C	1h																					
Resistance to Soldering heat	<p>Reflow soldering method Peak: 255 ±5 °C, 220 ±5 °C, 40s At electrode temperature of the specimen.</p>  <p>The specimen shall be passed through the reflow furnace with the condition shown in the above profile for 1 time. The specimen shall be stored at standard atmospheric conditions for 1h, after which the measurement shall be made. Test board shall be 1.6 mm thick. Base material shall be glass fabric base epoxy resin.</p>																						
Solder ability	<p>Immerse the pins melt solder at 260°C+5/-0°C for 5 sec.</p>	<p>More then 95% of total area of the pins should be covered with solder</p>																					

3.4 Mechanical Test

Items	Conditions	Specifications
Vibration	600-3300rpm amplitude 1.5mm 3 directions 2 H each	There shall be no damage.
Drop	On maple plate from 1 m high 3 times	
Lead pull	Pull with 1 kg force for 30 seconds	
Lead bend	90° bending with 500g weigh 2 times	

3.5 Voltage Discharge Test

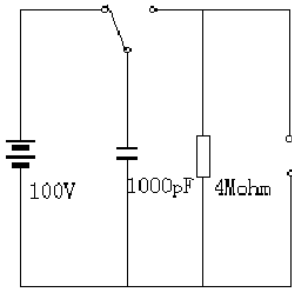
Item	Condition	Specifications
Surge	Between any two electrode 	There shall be no damage

3.6 Frequency response

CH1 S21 log MAG 10 dB/ REF -21 dB 4: -0343 dB

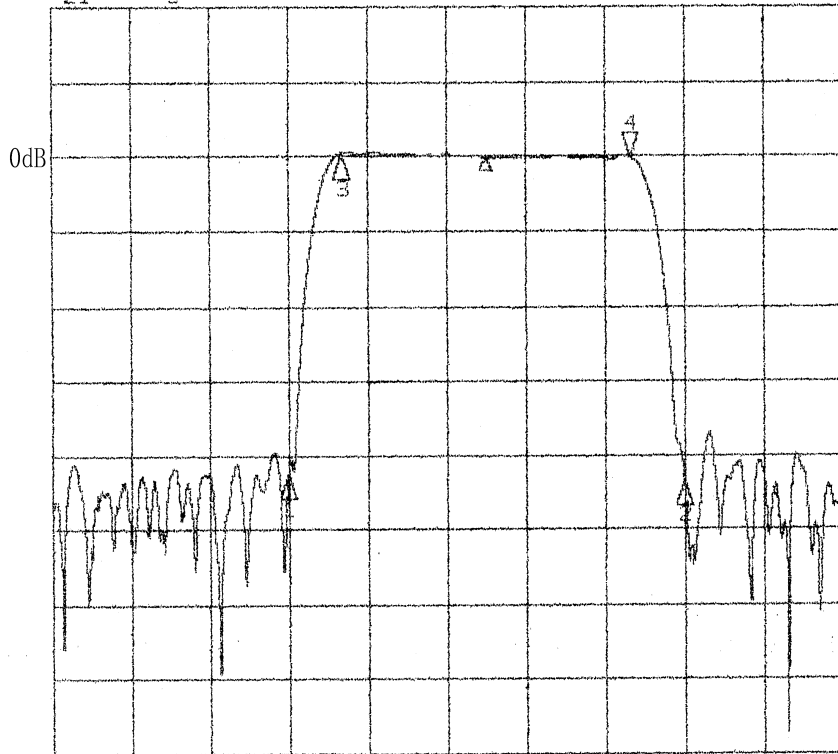

START 25.000 000 MHz STOP 45.000 000 MHz

CH1 S21 delay 30 ns/ REF 1.303 μ s 2 1.1845 μ s
CH2 S21 log MAG 1 dB/ REF -21 dB 3 -21.128 dB

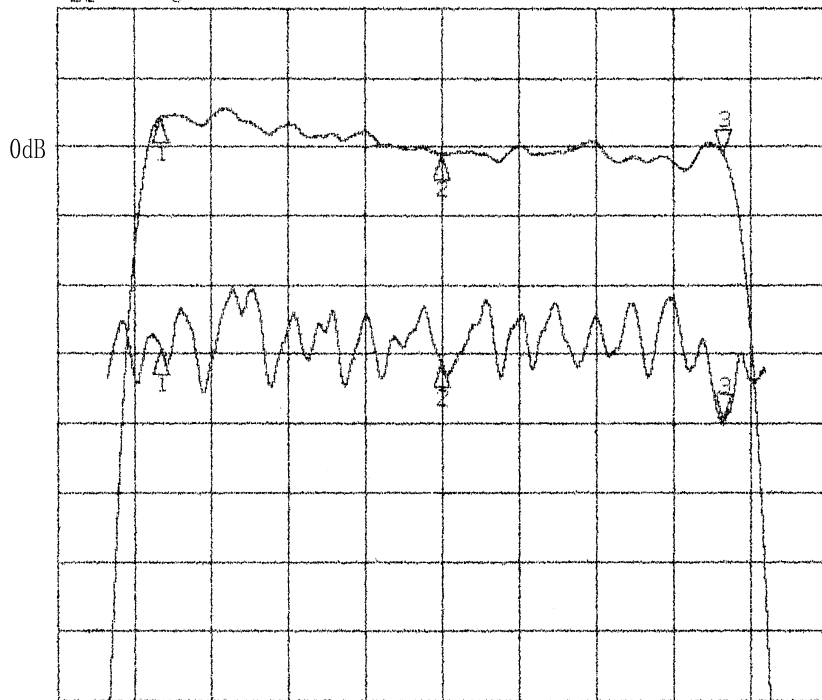

CENTER 36.000 000 MHz SPAN 10.000 000 MHz

