

### FEATURES

- 10 mbar to 5 bar, absolute, gage or differential pressure
- Digital I<sup>2</sup>C-bus and analog output
- Precision ASIC signal conditioning
- Calibrated and temperature compensated
- SMT and DIP housings
- RoHS compliant

### MEDIA COMPATIBILITY

To be used with non-corrosive, non-ionic working fluids such as clean dry air, dry gases and the like.

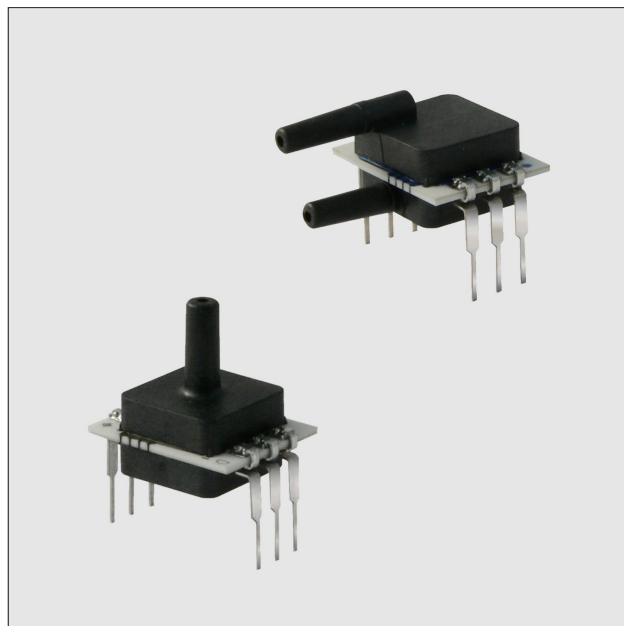

### SPECIFICATIONS

#### Maximum ratings

Supply voltage $V_s$	
HDI...3	2.7 ... 3.3 $V_{DC}$
HDI...5	4.5 ... 5.5 $V_{DC}$ max. 6.50 $V_{DC}$

Output current	
Sink	1 mA
Source	1 mA

#### Lead specifications

Average preheating temperature gradient	2.5 K/s
Soak time	ca. 3 min
Time above 217°C	50 s
Time above 230°C	40 s
Time above 250°C	15 s
Peak temperature	260°C
Cooling temperature gradient	-3.5 K/s

#### Temperature ranges<sup>5</sup>

Compensated	0 ... +85 °C
Operating	-20 ... +85 °C
Storage	-40 ... +125 °C

### ELECTRICAL CONNECTION

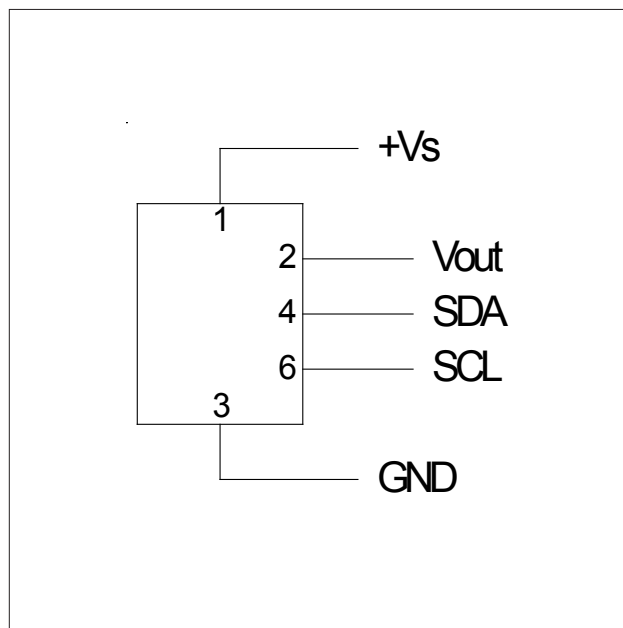

### PRESSURE SENSOR CHARACTERISTICS

(T<sub>A</sub>=25 °C, RH=50 %)

Part no.	Operating pressure	Proof pressure <sup>1</sup>	Burst pressure <sup>2</sup>
HDIM010...B...	0...±10 mbar	150 mbar	200 mbar
HDIM020...B...	0...±20 mbar	150 mbar	200 mbar
HDIM050...B...	0...±50 mbar	550 mbar	800 mbar
HDIM100...B...	0...±100 mbar	1 bar	1.5 bar
HDIM200...B...	0...±200 mbar	1 bar	1.5 bar
HDIM500...B...	0...±500 mbar	1 bar	1.5 bar
HDIB001...B...	0...±1 bar	2 bar	3 bar
HDIM010...U...	0...10 mbar	150 mbar	200 mbar
HDIM020...U...	0...20 mbar	150 mbar	200 mbar
HDIM050...U...	0...50 mbar	550 mbar	800 mbar
HDIM100...U...	0...100 mbar	1 bar	1.5 bar
HDIM200...U...	0...200 mbar	1 bar	1.5 bar
HDIM500...U...	0...500 mbar	1 bar	1.5 bar
HDIB001...U...	0...1 bar	2 bar	3 bar
HDIB002...U...	0...2 bar	4 bar	6 bar
HDIB005...U...	0...5 bar	7 bar	7 bar
HDI0611AR...	600...1100 mbar(a)	2 bara	3 bara
HDI0811AR...	800...1100 mbar(a)	2 bara	3 bara

**Other pressure ranges are available on request. Please contact First Sensor.**

#### Specification notes:

1. Proof pressure is the maximum pressure which may be applied without causing durable shifts of the electrical parameters of the sensing element.
2. Burst pressure is the maximum pressure which may be applied without causing damage to the sensing element or leaks to the housing.
3. Full Scale Span (FSS) is the algebraic difference between the output signal for the highest and lowest specified pressure.
4. Total accuracy is the combined error from offset and span calibration, linearity, pressure hysteresis, and temperature effects. Linearity is the measured deviation based on a straight line. Hysteresis is the maximum output difference at any point within the operating pressure range for increasing and decreasing pressure. Calibration errors include the deviation of offset and full scale from nominal values.
5. Extended temperature ranges on request. Please contact First Sensor.
6. Max. delay time between pressure change at the pressure die and signal change at the output.
7. The response time depends on the adjusted internal A/D resolution of the sensor. For 12 bit it is typ. 0.5 ms. Other A/D resolutions and response time are available on request. Please contact First Sensor for further information.
8. Sensors with lower current consumption are available on request. Please contact First Sensor for further information.

# HDI Series

## Amplified pressure sensors

### PERFORMANCE CHARACTERISTICS

( $V_S=5.0 V_{DC}$ ,  $T_A=25\text{ }^\circ\text{C}$ ,  $RH=50\%$ , analog output signal is **ratiometric** to  $V_S$ , digital output signal is **not ratiometric** to  $V_S$ )

#### All HDI...P5 devices ( $V_S = 5.0$ )

Characteristics	Min.	Typ.	Max.	Units
Total accuracy (0...85°C) <sup>4</sup>	all barometric devices		±1.0	%FSS
	all other devices		±0.5	
Response delay <sup>6,7</sup>		0.5		ms
A/D resolution <sup>7</sup>		12		bit
D/A resolution			11	
Current consumption <sup>8</sup>		5		mA

#### All HDI...R...P5 (barometric devices)

Characteristics	Min.	Typ.	Max.	Units
ANALOGUE PERFORMANCE CHARACTERISTIC				
Output at min. specified pressure	0.46	0.50	0.54	V
Full scale span (FSS) <sup>3</sup>		4.00		
Full scale output	4.46	4.50	4.54	
DIGITAL PERFORMANCE CHARACTERISTIC				
Output at min. specified pressure	3015	3277	3539	counts
Full scale span (FSS) <sup>3</sup>		26214		
Full scale output	29228	29490	29752	

#### All HDI...U...P5 (unidirectional devices)

Characteristics	Min.	Typ.	Max.	Units
ANALOG PERFORMANCE CHARACTERISTIC				
Zero pressure offset	0.48	0.50	0.52	V
Full scale span (FSS) <sup>3</sup>		4.00		
Full scale output	4.48	4.50	4.52	
DIGITAL PERFORMANCE CHARACTERISTIC				
Zero pressure offset	3146	3277	3408	counts
Full scale span (FSS) <sup>3</sup>		26214		
Full scale output	29359	29490	29621	

#### All HDI...B...P5 (bidirectional devices)

Characteristics	Min.	Typ.	Max.	Units	
ANALOG PERFORMANCE CHARACTERISTIC					
Zero pressure offset	2.48	2.50	2.52	V	
Full scale span (FSS) <sup>3</sup>		4.00			
Output	at max. specified pressure	4.48	4.50		4.52
	at min. specified pressure	0.48	0.50		0.52
DIGITAL PERFORMANCE CHARACTERISTIC					
Zero pressure offset	16252	16384	16515	counts	
Full scale span (FSS) <sup>3</sup>		26214			
Output	at max. specified pressure	29359	29490		29621
	at min. specified pressure	3146	3277		3408

# HDI Series

## Amplified pressure sensors

### PERFORMANCE CHARACTERISTICS

( $V_S=3.0 V_{DC}$ ,  $T_A=25\text{ }^\circ\text{C}$ ,  $RH=50\%$ , analog output signal is **ratiometric** to  $V_S$ , digital output signal is **not ratiometric** to  $V_S$ )

#### All HDI...P3 devices ( $V_S = 3.0$ )

Characteristics	Min.	Typ.	Max.	Units
Total accuracy (0...85°C) <sup>4</sup>	all barometric devices		±1.0	%FSS
	all other devices		±0.5	
Response delay <sup>6,7</sup>		0.5		ms
A/D resolution <sup>7</sup>		12		bit
D/A resolution			11	
Current consumption <sup>8</sup>		3		mA

#### All HDI...R...P3 (barometric devices)

Characteristics	Min.	Typ.	Max.	Units
ANALOGUE PERFORMANCE CHARACTERISTIC				
Output at min. specified pressure	0.23	0.25	0.27	V
Full scale span (FSS) <sup>3</sup>		2.00		
Full scale output	2.23	2.25	2.27	
DIGITAL PERFORMANCE CHARACTERISTIC				
Output at min. specified pressure	2512	2731	2949	counts
Full scale span (FSS) <sup>3</sup>		21845		
Full scale output	24357	24575	24794	

#### All HDI...U...P3 (unidirectional devices)

Characteristics	Min.	Typ.	Max.	Units
ANALOG PERFORMANCE CHARACTERISTIC				
Zero pressure offset	0.24	0.25	0.26	V
Full scale span (FSS) <sup>3</sup>		2.00		
Full scale output	2.24	2.25	2.26	
DIGITAL PERFORMANCE CHARACTERISTIC				
Zero pressure offset	2621	2731	2840	counts
Full scale span (FSS) <sup>3</sup>		21845		
Full scale output	24466	24575	24684	

#### All HDI...B...P3 (bidirectional devices)

Characteristics	Min.	Typ.	Max.	Units
ANALOG PERFORMANCE CHARACTERISTIC				
Zero pressure offset	1.24	1.25	1.26	V
Full scale span (FSS) <sup>3</sup>		2.00		
Output	at max. specified pressure		2.24	
	at min. specified pressure		0.24	
DIGITAL PERFORMANCE CHARACTERISTIC				
Zero pressure offset	13545	13653	13762	counts
Full scale span (FSS) <sup>3</sup>		21845		
Output	at max. specified pressure		24466	
	at min. specified pressure		2621	

## I<sup>2</sup>C BUS

### Introduction

The HDI is capable to generate a digital output signal. The device runs a cyclic program, which will store a corrected pressure value with 12 bit resolution about every 250  $\mu$ s within the output registers of the internal ASIC. In order to use the sensor for digital signal readout, it should be connected to a bidirectional I<sup>2</sup>C-bus.

According to the I<sup>2</sup>C-bus specification, the bus is controlled by a master device, which generates the clock signal, controls the bus access and generates START and STOP conditions. The HDI is designed to work as a slave, hence it will only respond to requests from a master device.

### Digital I<sup>2</sup>C interface

The HDI complies with the following protocol (Fig. 1):

**Bus not busy:** During idle periods both data line (SDA) and clock line (SCL) remain HIGH.

**START condition (S):** HIGH to LOW transition of SDA line while clock (SCL) is HIGH is interpreted as START condition. START conditions are always generated by the master. Each initial request for a pressure value has to begin with a START condition.

**STOP condition (P):** LOW to HIGH transition of SDA line while clock (SCL) is HIGH determines STOP condition. STOP conditions are always generated by the master. More than one request for the current pressure value can be transmitted without generation of intermediate STOP condition.

**DATA valid (D):** State of data line represents valid data when, after START condition, data line is stable for duration of HIGH period of clock signal. Data on line must be changed during LOW period of clock signal. There is one clock pulse per bit of data.

**Acknowledge (A):** Data is transferred in pieces of 8 bits (1 byte) on serial bus, MSB first. After each byte receiving device – whether master or slave – is obliged to pull data line LOW as acknowledge for reception of data. Master must generate an extra clock pulse for this purpose. When acknowledge is missed, slave transmitter becomes inactive. It is on master either to send last command again or to generate STOP condition in that case.

**Slave address:** The I<sup>2</sup>C-bus master-slave concept requires a unique address for each device. The HDI has a preconfigured slave address (1111000xb). By factory programming it is possible to define a secondary slave address additional to the general one. According to I<sup>2</sup>C specification 127 different addresses are available. The sensor will then listen to both slave addresses. After generating a START condition the master sends the address byte containing a 7 bit address followed by a data direction bit (R/W). A "0" indicates a transmission from master to slave (WRITE), a "1" indicates a data request (READ).

**DATA operation:** The sensor starts to send 2 data bytes containing the current pressure value as a 15 bit information placed in the output registers.

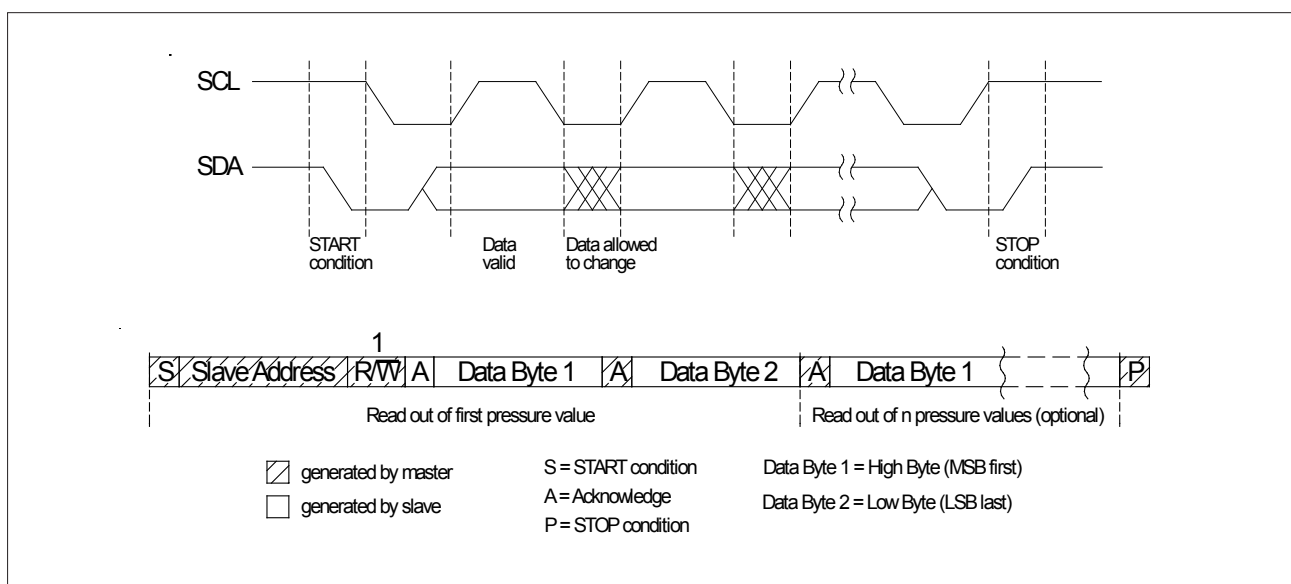

Fig. 1: I<sup>2</sup>C bus protocol

### I<sup>2</sup>C Interface Parameters

Parameter	Symbol	Min.	Typ.	Max.	Unit
Input high level		90		100	% of V <sub>s</sub>
Input low level		0		10	
Output low level				10	
Pull-up resistor		500			Ω
Load capacitance @ SDA	C <sub>SDA</sub>			400	pF
Input capacitance @ SDA/SCL	C <sub>I2C IN</sub>			10	
SCL clock frequency	F <sub>SCL</sub>	100*		400	kHz
Bus free time between STOP and START condition	t <sub>BUF</sub>	1.3			μs
Hold time (repeated) START condition, to first clock pulse	t <sub>HD,STA</sub>	0.8			
LOW period of SCL	t <sub>LOW</sub>	1.3			
HIGH period of SCL	t <sub>HIGH</sub>	0.6			
Setup time repeated START condition	t <sub>SU,STA</sub>	1			
Data hold time	t <sub>HD,DAT</sub>	0			
Data setup time	t <sub>SU,DAT</sub>	0.2			
Rise time of both SDA and SCL	t <sub>R</sub>			0.3	
Fall time of both SDA and SCL	t <sub>F</sub>			0.3	
Setup time for STOP condition	t <sub>SU,STO</sub>	0.6			

\* recommended

**Note:** First Sensor recommends communication speeds of at least 100 kHz (max. 400 kHz). Please contact us for further information.

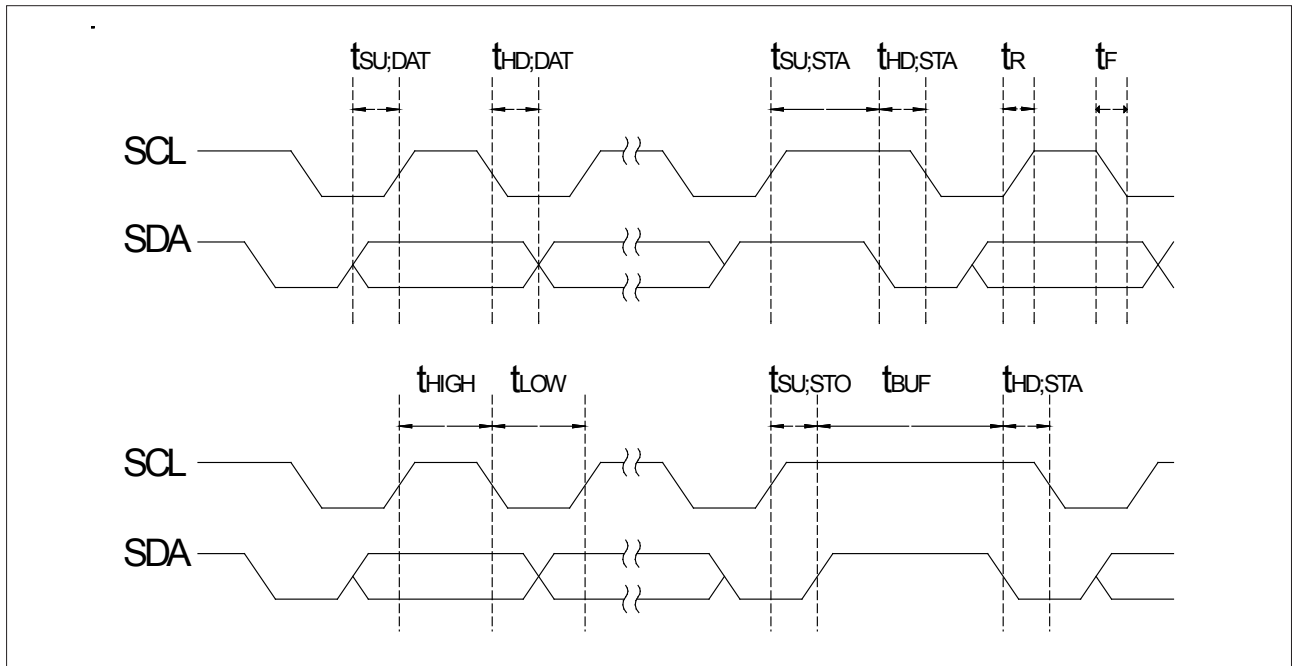
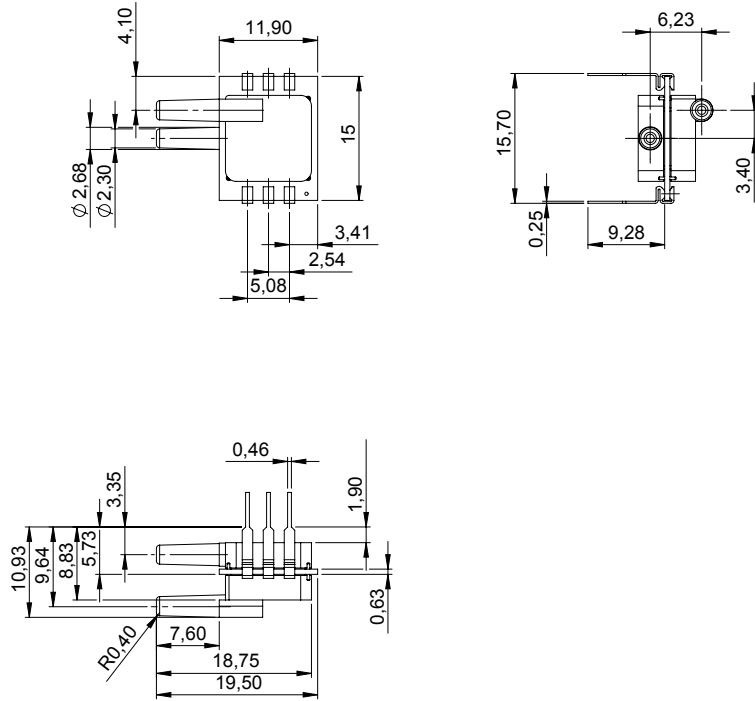
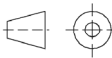

Fig. 2: Timing characteristics

### PHYSICAL DIMENSIONS

HDI...F... (DIP, 2 ports same side)



  
 first angle projection  
 dimensions in mm

HDI...E... (SMD, 2 ports same side)

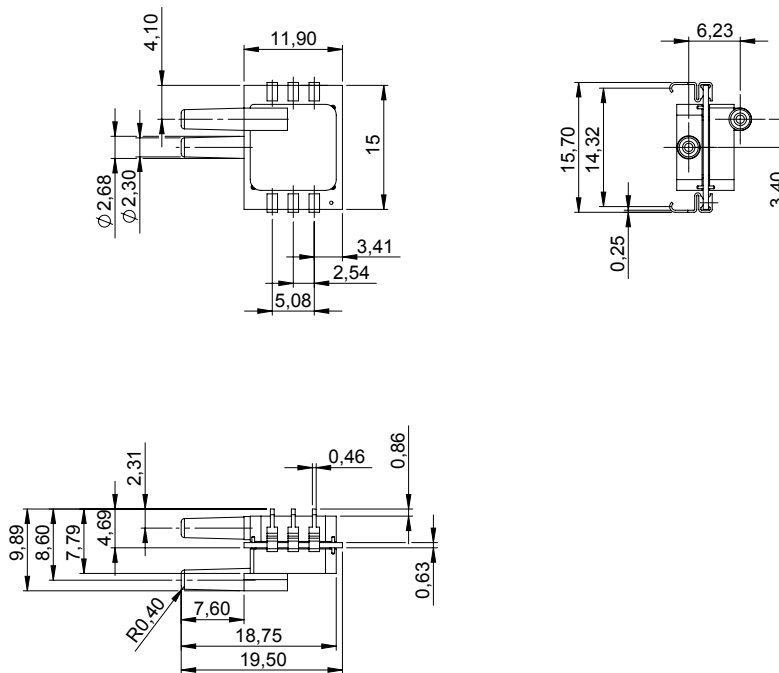

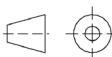
  
 first angle projection  
 dimensions in mm

### PHYSICAL DIMENSIONS (cont.)

#### HDI...Z... (DIP, 1 port axial)

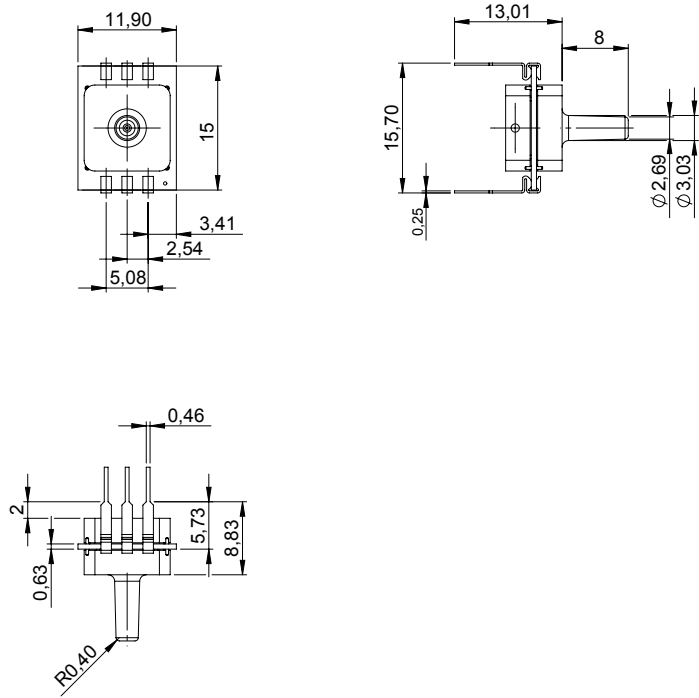

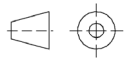
  
 first angle projection  
 dimensions in mm

#### HDI...Y... (SMD, 1 port axial)

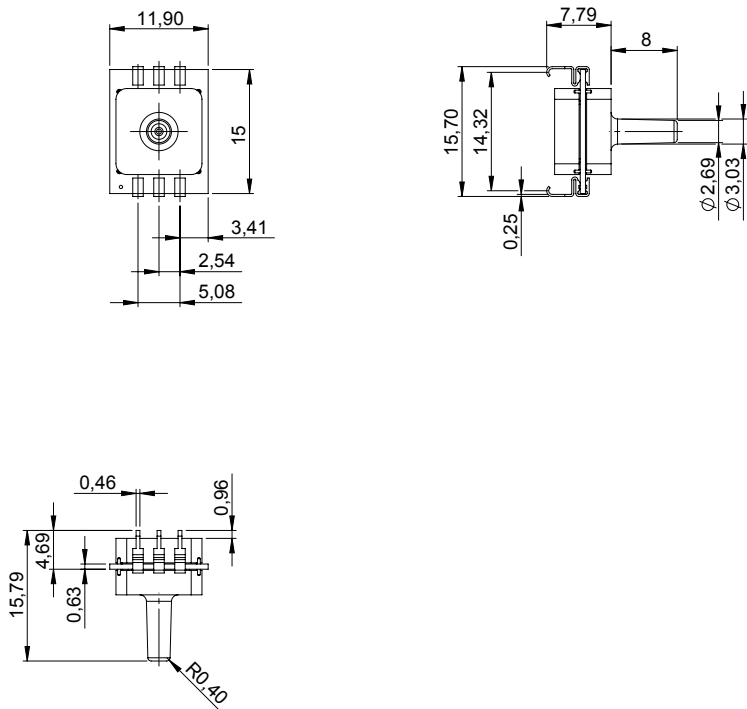

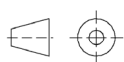
  
 first angle projection  
 dimensions in mm



# HDI Series

## Amplified pressure sensors

### ELECTRICAL CONNECTION (cont.)

HDI...A...  
(absolute)

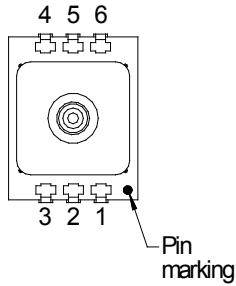

HDI...G...  
(gage)

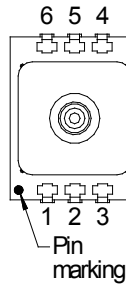

HDI...D...  
(differential)

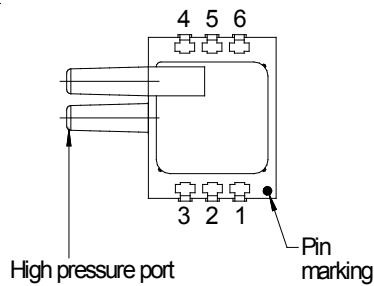

Pin	Connection
1	+Vs
2	+Vout
3	GND
4	SDA
5	I / C*
6	SCL

\* Internal connection.  
Do not connect for any reason

### ORDERING INFORMATION

Options	Series	Pressure range		Pressure mode		Calibration		Housing		Porting		Grade		Voltage	
	HDI	0611	600...1100 mbar	A*	Absolute	B*	Bidirectional	F*	DIP, 2 ports same side	8	Straight	P	Prime	5	5 V
		0811	800...1100 mbar	D	Differential	U	Unidirectional	E*	SMD, 2 ports same side					3	3 V
		M010	10 mbar	G	Gage	R**	Barometric	Z**	DIP, 1 port axial						
		M020	20 mbar					Y**	SMD, 1 port axial						
		M050	50 mbar												
		M100	100 mbar												
		M200	200 mbar												
		M500	500 mbar												
		B001	1 bar												
		(B001A)	1 bara												
		B002	2 bar												
		B005	5 bar												
				* only from 1 bar		* only up to 1 bar ** for pressure ranges 0611, 0811		* standard for differential devices, "D" ** standard for absolute and gage devices, "A" and "G"							
Example:		HDI	M050	G		U		Z		8		P		5	

Note: Devices highlighted in grey are preferred stock items

First Sensor reserves the right to make changes to any products herein. First Sensor does not assume any liability arising out of the application or use of any product or circuit described herein, neither does it convey any license under its patent rights nor the rights of others.