

# HDG1602F-1

## Dimensional Drawing

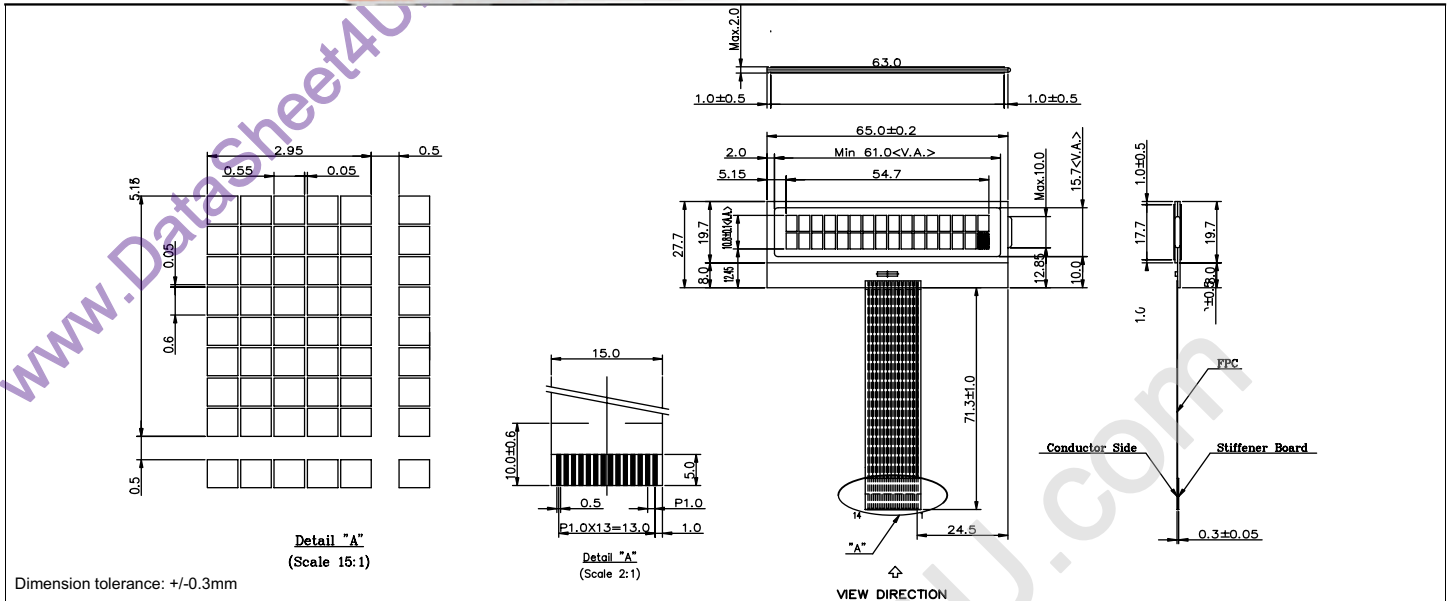

16 Character x 2 Line



### Features

Character Format .....5x7 Dots with Cursor  
 Connection .....Flat Flex Cable  
 Options.....STN, Reflective Polarizer  
 Characters.....240 in ROM, 8 user designed in RAM

### Physical Data

Module Size.....65.0W x 27.7H x 2.0T mm  
 Viewing Area Size.....61.0W x 15.7H mm  
 Character Size.....2.95W x 5.15H mm  
 Weight.....6.8 g

### Absolute Maximum Ratings

PARAMETER	SYMBOL	MIN	MAX	UNIT
SUPPLY VOLTAGE	$V_{DD}-V_{SS}$	-0.3	6.0	V
SUPPLY VOLTAGE FOR LCD	$V_{DD}-V_L$	0	11.0	V
INPUT VOLTAGE	$V_{IN}$	$V_{SS}$	$V_{DD}$	V
OPERATING TEMPERATURE	$T_{OP}$	0	50	°C
STORAGE TEMPERATURE	$T_{STG}$	-20	70	°C

### Electrical Characteristics (VDD=5.0±0.25V 25°C)

PARAMETER	SYM	CONDITION	MIN	TYP	MAX	UNIT
INPUT HIGH VOLTAGE	$V_{IH}$	-	$0.7V_{DD}$	-	$V_{DD}$	V
INPUT LOW VOLTAGE	$V_{IL}$	-	$V_{SS}$	-	$0.2V_{DD}$	V
OUTPUT HIGH VOLTAGE	$V_{OH}$	$I_{OH}=0.2mA$	$0.8V_{DD}$	-	$V_{DD}$	V
OUTPUT LOW VOLTAGE	$V_{OL}$	$I_{OL}=1.2mA$	$V_{SS}$	-	$0.2V_{DD}$	V
POWER SUPPLY CURRENT	$I_{DD}$	$V_{DD}=5V$	-	0.82	1.4	mA
POWER SUPPLY FOR LCD	$V_{DD}-V_L$	$T_A=25°C$	4.1	4.5	4.9	V
DRIVE METHOD	1/16 Duty					

### Block Diagram

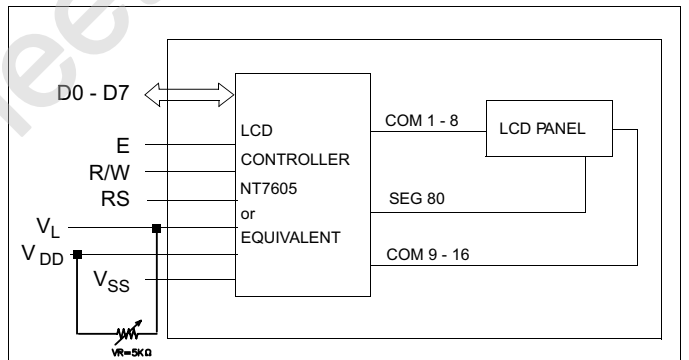

### Pin Connections

PIN NO.	SYMBOL	LEVEL	FUNCTION
1	RS	H/L	H: Data input L: Instruction data input
2	R/W	H/L	H: Data read L: Data write
3	E	H,HI L	Enable signal
4	D0	H/L	Data bus
5	D1	H/L	
6	D2	H/L	
7	D3	H/L	
8	D4	H/L	
9	D5	H/L	
10	D6	H/L	
11	D7	H/L	Power supply
12	$V_{SS}$	0V	
13	$V_{DD}$	5V	
14	$V_L$	~+0.6V	