

液晶之友 电话: 020-33819057

[Http://www.lcdfriends.com](http://www.lcdfriends.com)

**HANTRONIX**

## PRODUCT SPECIFICATION

# HDM64GS12-R

128 x 64 GRAPHICS  
LCD DISPLAY MODULE

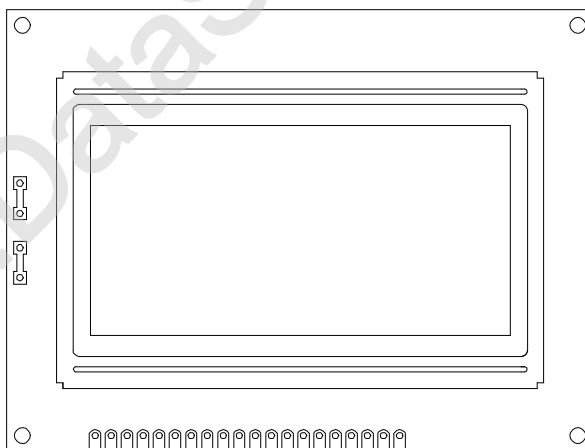

<b>HANTRONIX, INC.</b> 10080 BUBB RD. CUPERTINO, CA 95014	Q.A.:	REV.:	<b>HDM64GS12-R</b>	SHEET 1 OF 13
	JK	1.0		DATE: 9/3/03

## I . General Specifications

### 1. Features

- (1) Model: HDM64GS12\_-R
- (2) Drive Method: 1/64 Duty, 1/9 Bias
- (3) Viewing Direction: 6:00 or 12:00 O'clock
- (4) Operating Temperature: Normal (0°C~50°C) or Extended (-20°C~70°C)
- (5) Storage Temperature: Normal (-20°C~70°C) or Extended (-30°C~85°C)
- (6) Display Type: FSTN, Gray or Yellow STN, Positive/ Negative
- (7) Backlight: None, LED (Yellow Green)
- (8) DC-to-DC Converter: Built-in
- (9) Controller: Samsung KS108B

### 2. Mechanical Data

- (1) Resolution: 128 dots x 64 dots
- (2) Module Size: 93.0 l \* 70.0 w mm
- (3) Bessel Size: 77.2 l \* 50.2 w mm
- (4) Viewing Area: 72.0 l \* 40.0 w mm
- (5) Dot Size: 0.48 w \* 0.48 h mm
- (6) Dot Pitch: 0.52 w \* 0.52 h mm

<b>HANTRONIX, INC.</b> 10080 BUBB RD. CUPERTINO, CA 95014	Q.A.:	REV.:	<b>HDM64GS12-R</b>	SHEET 2 OF 13
	JK	1.0		DATE: 9/3/03

3. Pin Connections:

Pin No.	Symbol	Function
1	VSS	Ground(0v)
2	VDD	Logic Supply Voltage(+5.0v)
3	V0	LCD Driver Voltage Input(+9.7v)
4	RS	Data Or Instruction
5	R/W	Read/Write Select
6	E	Enable Signal
7~14	DB0~DB7	Data Bus Line
15	Cs1	Chip Selection(Segment Driver 1)
16	Cs2	Chip Selection(Segment Driver 2)
17	RSTB	Reset Signal
18	Vout	Dc-Dc-Converter Output
19-20	A,K	LED Backlight

4. Timing Characteristics: (VDD=5V ± 10%)

(1) Common Driver :

Characteristic	Symbol	Min.	Typ.	Max.	Unit
Data Setup Time	Tsu	20	--	--	us
Data Hold Time	Tdh	40	--	--	
Data Delay Time	Td	5	--	--	
FRM Delay Time	Tdf	-2	--	2	
M Delay Time	Tdm	-2	--	2	
Cl2 Low Level Width	Twlc	35	--	--	
Cl2 High Level Width	Twhc	35	--	--	
Clk1 Low Level Width	Twl1	700	--	--	ns
Clk2 Low Level Width	Twl2	700	--	--	

<b>HANTRONIX, INC.</b> 10080 BUBB RD. CUPERTINO, CA 95014	Q.A.:	REV.:	<b>HDM64GS12-R</b>	SHEET 3 OF 13
	JK	1.0		DATE:

Clk1 High Level Width	Twh1	2100	--	--	ns
Clk2 High Level Width	Twh2	2100	--	--	
Clk1-Clk2 Phase Difference	Td12	700	--	--	
Clk2-Clk1 Phase Difference	Td21	700	--	--	
Clk1,Clk2 Rise/Fall Time	Tr/Tf	--	--	150	

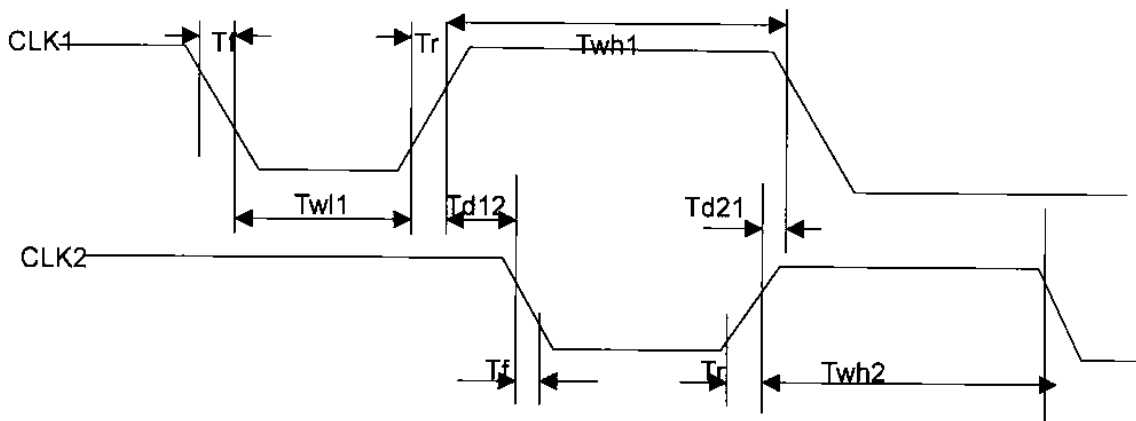
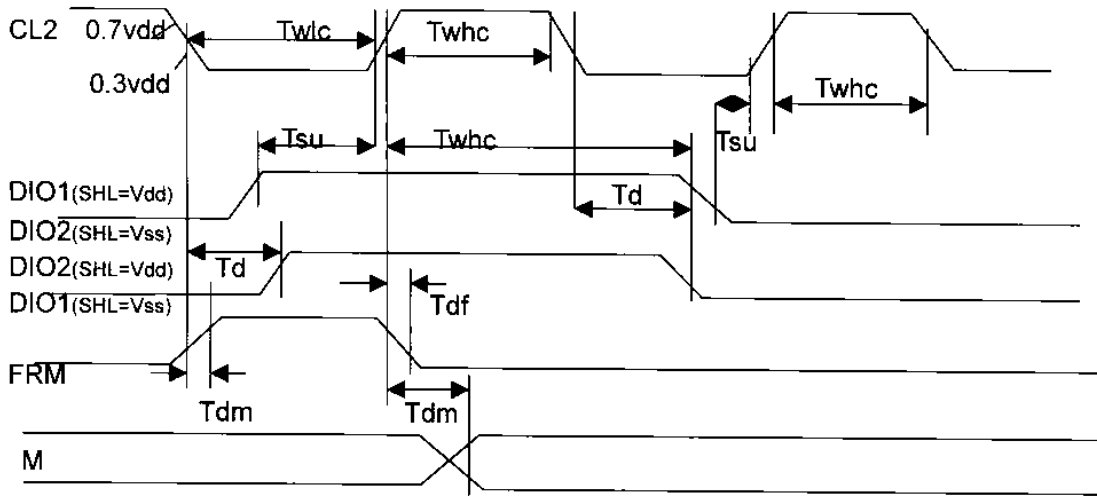

(2) Segment Driver:

A. Clock Timing:

Characteristic	Symbol	Min.	Typ.	Max.	Unit
Clk1, Clk2 Cycle Time	Tcy	2.5	--	20	$\mu$ s
Clk1 "Low" Level Width	Twl1	625	--	--	ns
Clk2 "Low" Level Width	Twl2	625	--	--	
Clk1 "High" Level Width	Twh1	1875	--	--	
Clk2 "High" Level Width	Twh2	1875	--	--	
Clk1-Clk2 Phase Difference	Td12	625	--	--	
Clk2-Clk1 Phase Difference	Td21	625	--	--	
Clk1, Clk2 Rise Time	Tr	--	--	150	
Clk1, Clk2 Fall Time	Tf	--	--	150	

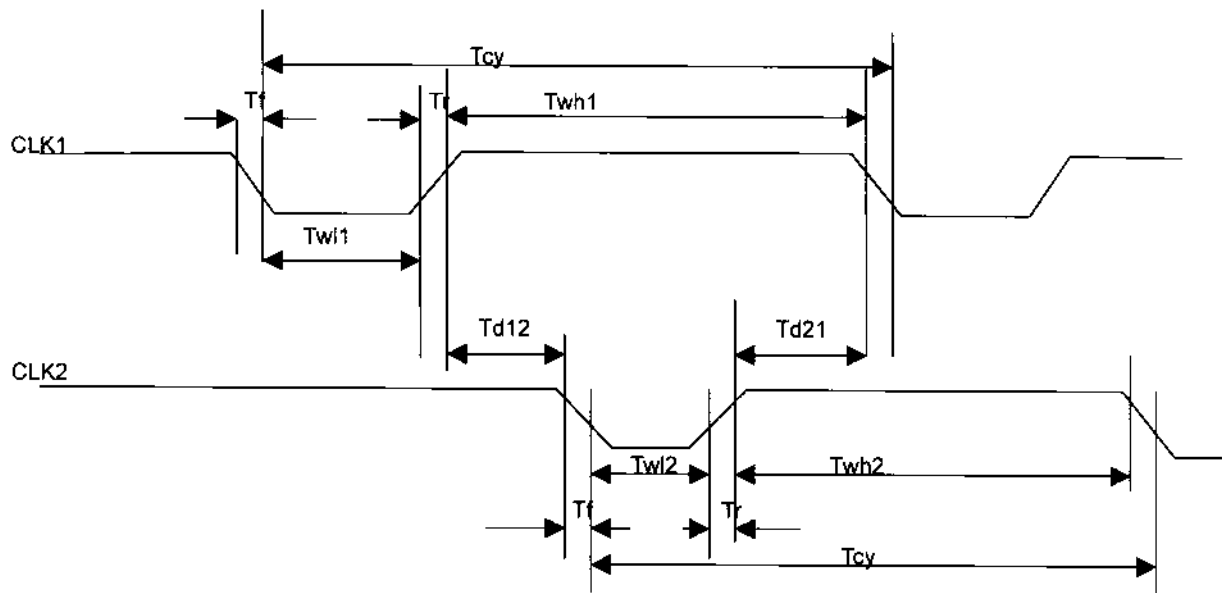

B. Display Control Timing

Characteristic	Symbol	Min.	Typ.	Max.	Unit
Frm Delay Time	Tdf	-2	--	+2	$\mu$ s
M Delay Time	Tdm	-2	--	+2	$\mu$ s
Cl"Low" Level Width	Twl	35	--	--	$\mu$ s
Cl"High" Level Width	Twh	35	--	--	$\mu$ s

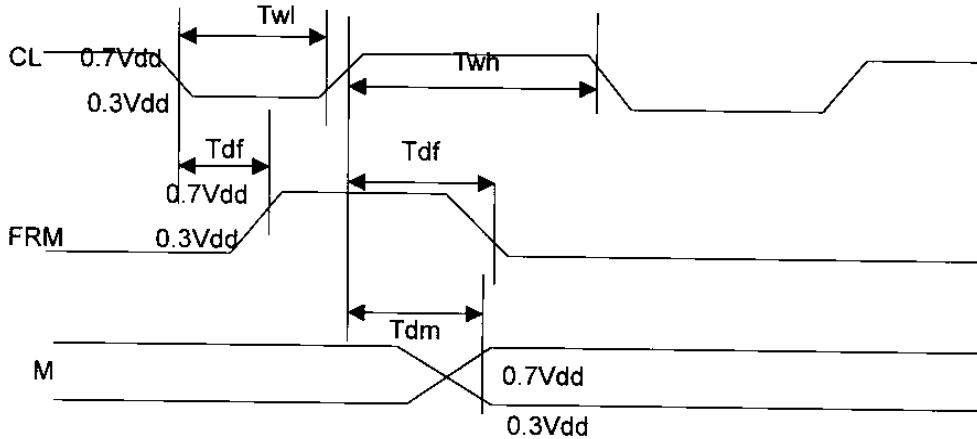

C. Mpu Interface:

Characteristic	Symbol	Min.	Typ.	Max.	Unit
E Cycle	Tc	1000	--	--	ns
E High Level Width	Twh	450	--	--	
E Low Level Width	Twl	450	--	--	
E Rise Time	Tr	--	--	25	
E Fall Time	Tf	--	--	25	
Address Set-Up Time	Tasu	140	--	--	
Address Hold Time	Tah	10	--	--	
Data Set-Up Time	Tdsu	200	--	--	
Data Delay Time	Td	--	--	320	
Data Hold Time(Write)	Tdhw	10	--	--	
Data Hold Time(Read)	Tdhr	20	--	--	

Mpu Write Timing:

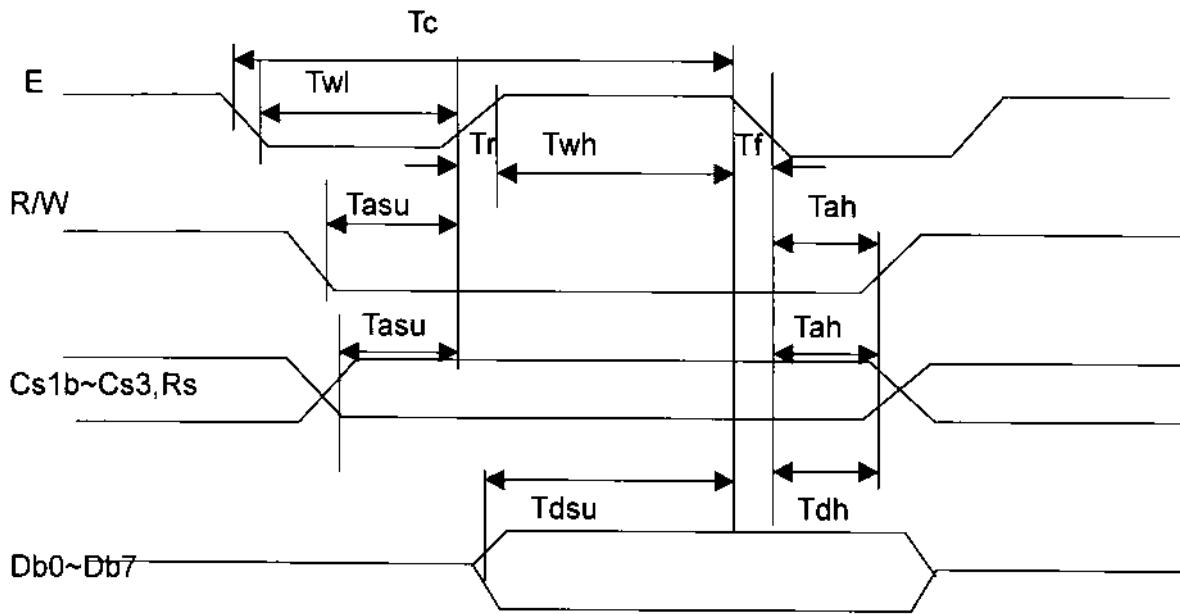

Mpu Read Timing:

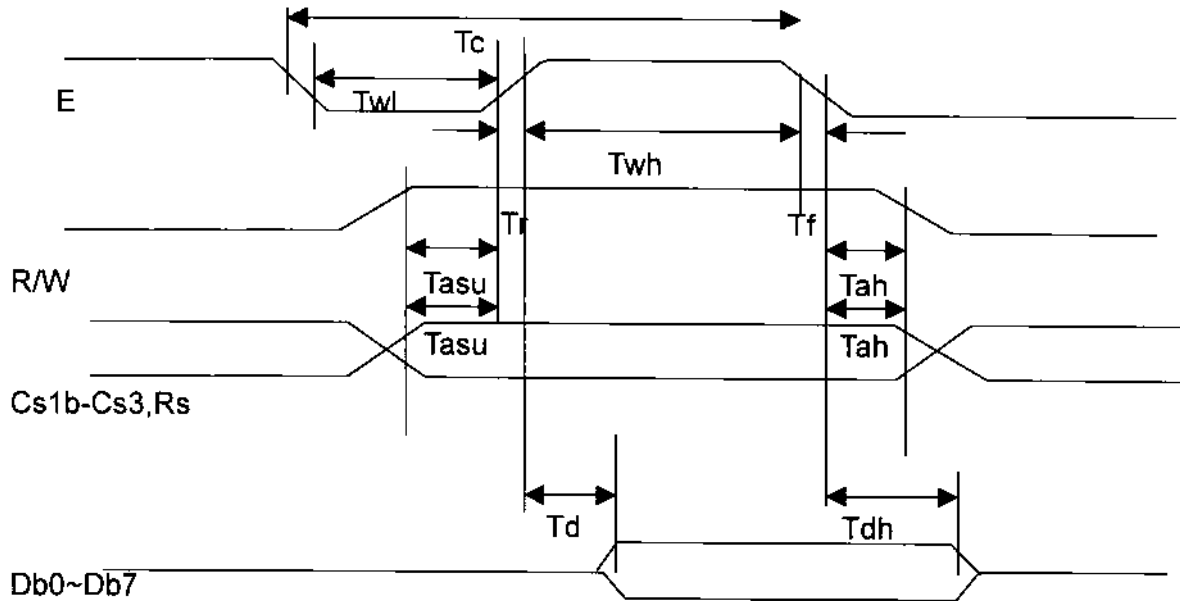

<b>HANTRONIX, INC.</b> 10080 BUBB RD. CUPERTINO, CA 95014	Q.A.:	REV.:	<b>HDM64GS12-R</b>	SHEET 7 OF 13
	JK	1.0		DATE:

## II .The Characteristics and The Reliability Test

### 1.Electro-Optic Characteristics:

Condition:TEMP=(23±3)°C Hum=(70±5)%RH

V<sub>dd</sub>: 5.0V

F<sub>osc</sub>: 450KHZ

NO	Item	Symbol	Min	Typ.	Max	Unit	Condition
1	Supply Voltage(Logic)	V <sub>dd</sub> -V <sub>ss</sub>	4.5	5.0	5.5	V	
2	Supply Current (Logic)	I <sub>dd</sub>		2.30		mA	V <sub>dd</sub> =5V
3	LCD Operating Voltage	V <sub>dd</sub> -V <sub>0</sub>		9.9		V	0°C
			9.2	9.7	10.2	V	25°C
				9.5		V	50°C
4	Response Time	T <sub>on</sub>		72		ms	
		T <sub>off</sub>		202		ms	
5	Contrast	CR	3				
6	Viewing Angel	12H	θ 1		55		De g.  (CR≥ 3.0)
		6H	θ 2		68		
		3H	θ 3		60		
		9H	θ 4		60		
7	LCD Threshold Voltage	V <sub>th</sub>		1.22		V	25°C

### 2. Absolute Maximum Ratings(LED unit):

Item	Symbol	Typ.	Rating.	Unit	Condition
Forward Current	I <sub>FM</sub>		720	mA	T <sub>a</sub> =25°C
Peak forward current	I <sub>FP</sub>		2160	mA	1 msec plus 10% duty cycle
Reverse Voltage	V <sub>R</sub>		8	V	T <sub>a</sub> =25°C
Power Dissipation	P <sub>D</sub>		3600	mW	T <sub>a</sub> =25°C

### 3. Electrical-optical Characteristics(LED unit):

Ltem	Symbol	Min	Typ	Max	Unit	Condition
Forward	V <sub>F</sub>	3.9	4.1	4.3	V	I <sub>F</sub> =360mA
Reverse current	I <sub>R</sub>			3600	uA	V <sub>R</sub> =8V
Luminous	L <sub>V</sub>	184	230		cd/m <sup>2</sup>	I <sub>F</sub> =360mA
Color	Yellow/Green					

<b>HANTRONIX, INC.</b> 10080 BUBB RD. CUPERTINO, CA 95014	Q.A.:	REV.:	<b>HDM64GS12-R</b>	SHEET 8 OF 13
	JK	1.0		DATE:



### III. The LCD Measuring Method and Equipment

#### 1. Current Consumption Measuring

##### (1) Equipment

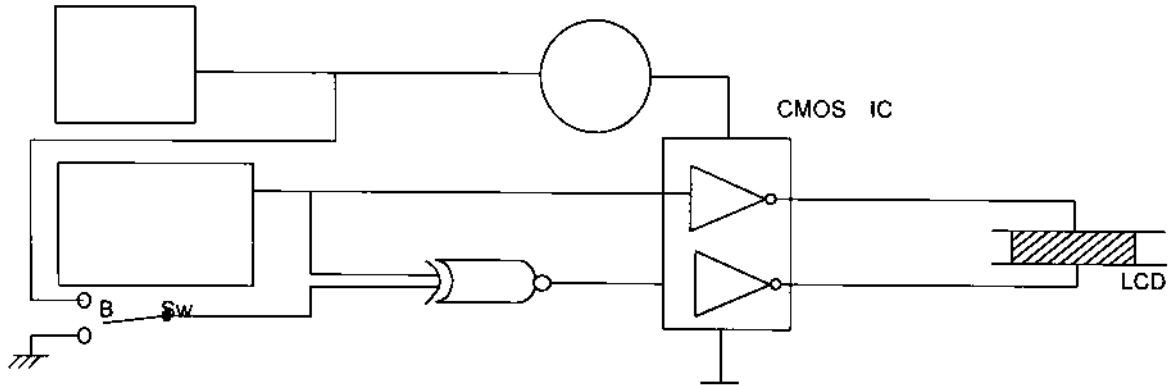

##### (2) Condition

Operating Frequency: 128HZ

Operating Voltage (RMS): Selected Voltage

#### 2. Threshold Voltage and Response Time Measuring

##### (1) Equipment

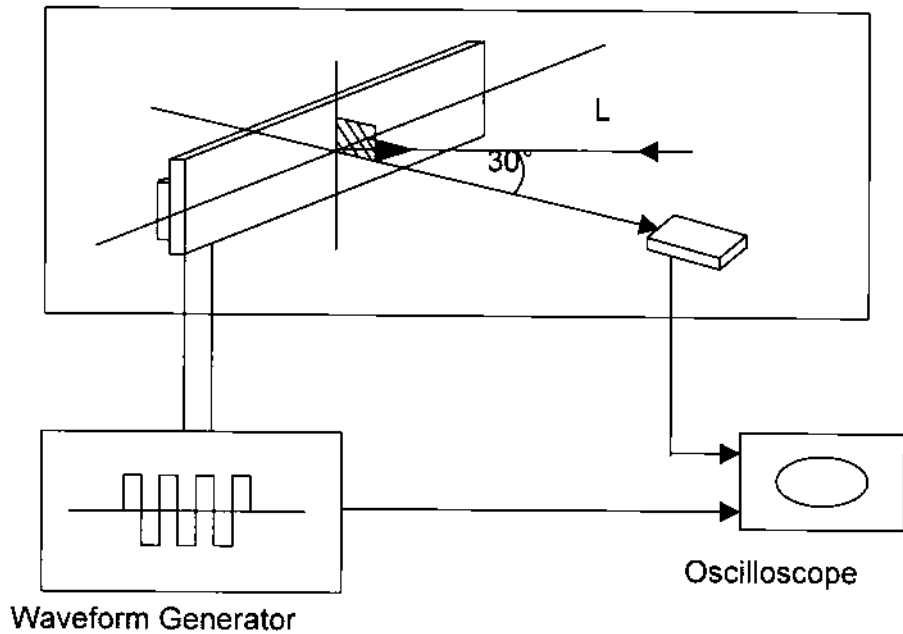

(2) Definition

A. Threshold Voltage ( $V_{th}$ )

Brightness

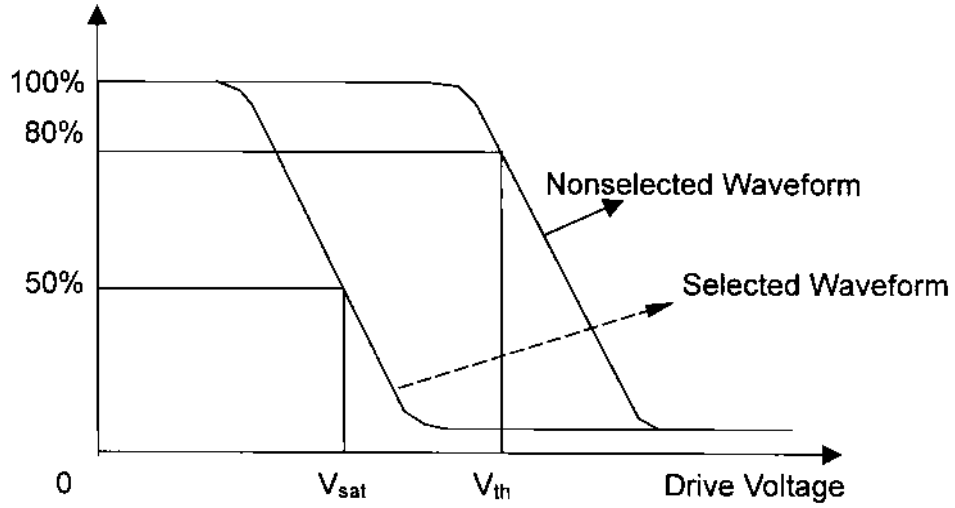

B. Response Time

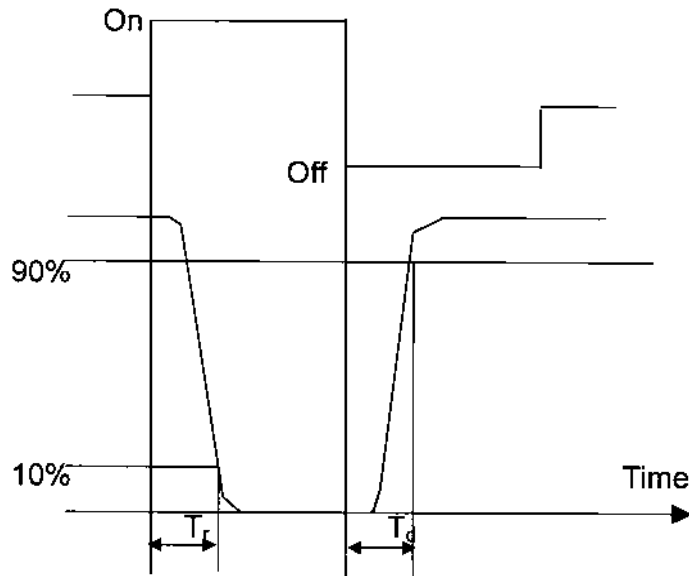

<b>HANTRONIX, INC.</b> 10080 BUBB RD. CUPERTINO, CA 95014	Q.A.:	REV.:	<b>HDM64GS12-R</b>	SHEET 10 OF 13
	JK	1.0		DATE: 9/3/03

### 3. Contrast Measuring

#### (1) Equipment

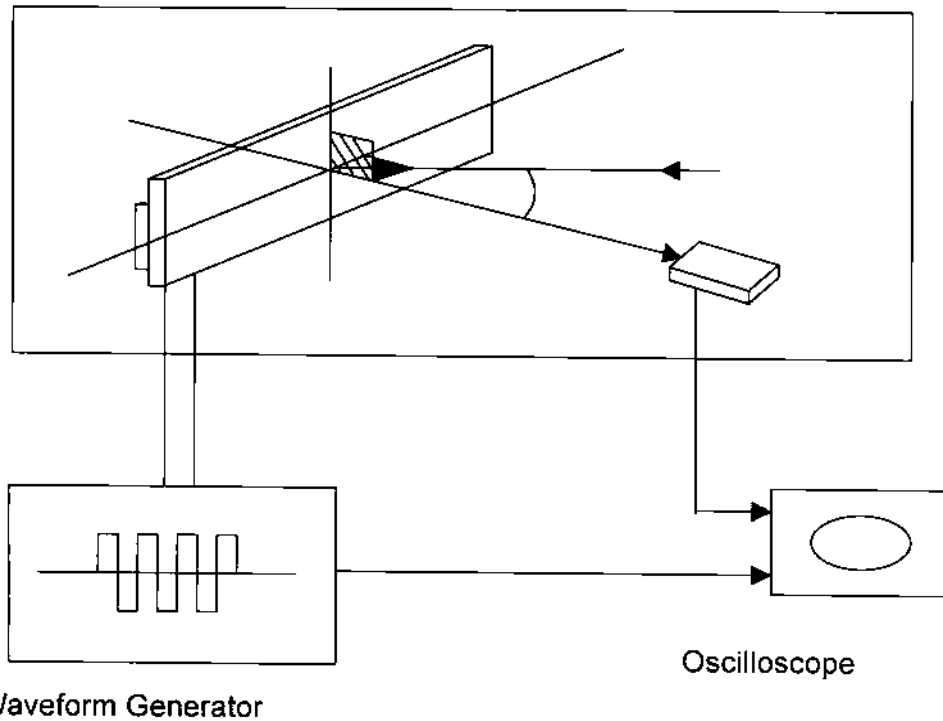

#### (2) Definition:

##### A. Viewing Angle:

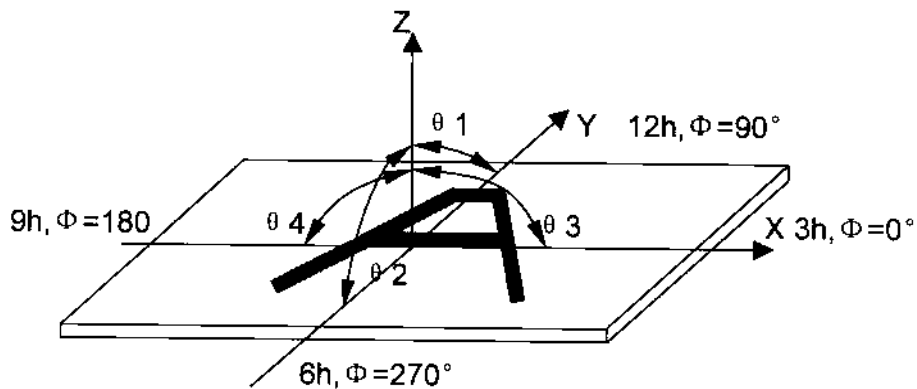

##### B. Contrast Ratio (Positive)

$$CR = \frac{\text{Brightness of non-selected wave-form}}{\text{Brightness of selected wave-form}}$$

HANTRONIX, INC.  
10080 BUBB RD.  
CUPERTINO, CA 95014

Q.A.:  
JK

REV.:  
1.0

HDM64GS12-R

SHEET 11 OF 13

DATE:  
9/3/03

## IV. Block Diagram

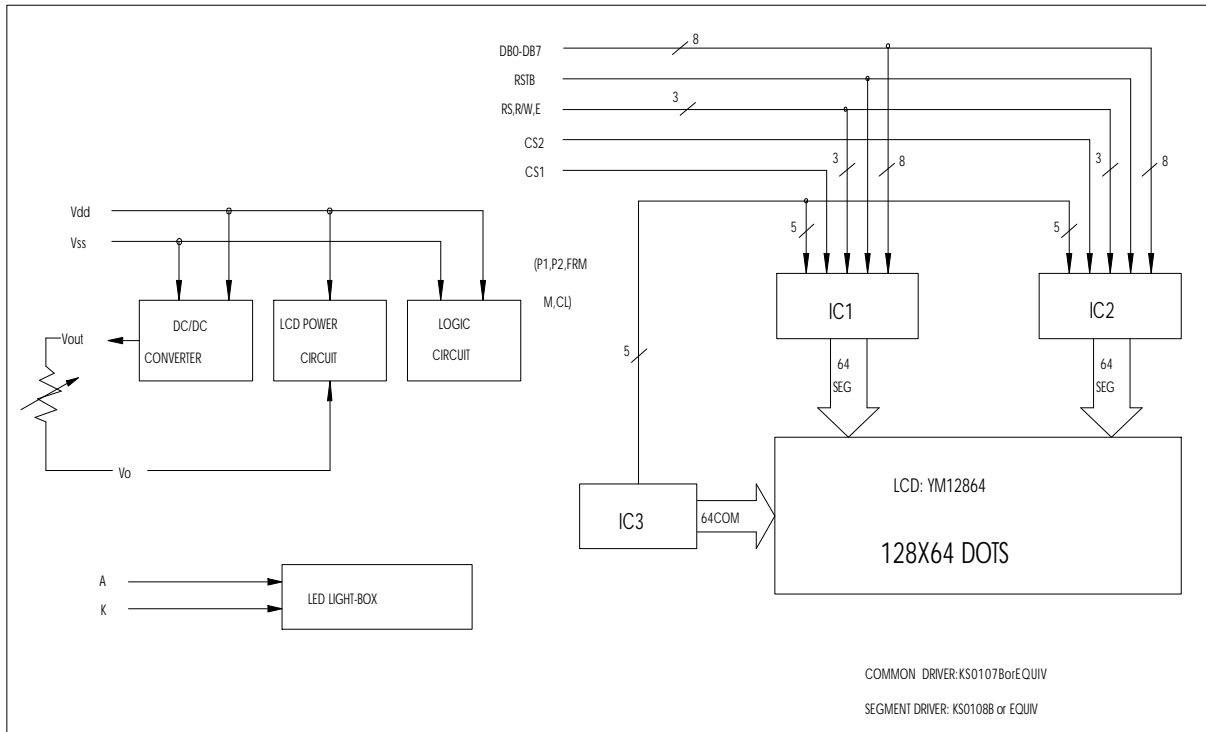

PIN NO.	1	2	3	4	5	6	7	8	9	10	11	12	13	14	15	16	17	18	19	20
SYMBOL	Vss	Vdd	Vo	RS	R/W	E	DB0	DB1	DB2	DB3	DB4	DB5	DB6	DB7	CS1	CS2	RSTB	Vout	A	K

**HANTRONIX, INC.**  
10080 BUBB RD.  
CUPERTINO, CA 95014

Q.A.:  
JK

REV.:  
1.0

**HDM64GS12-R**

SHEET 12 OF 13

DATE:  
9/3/03

# V. Drawing

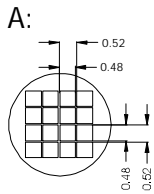
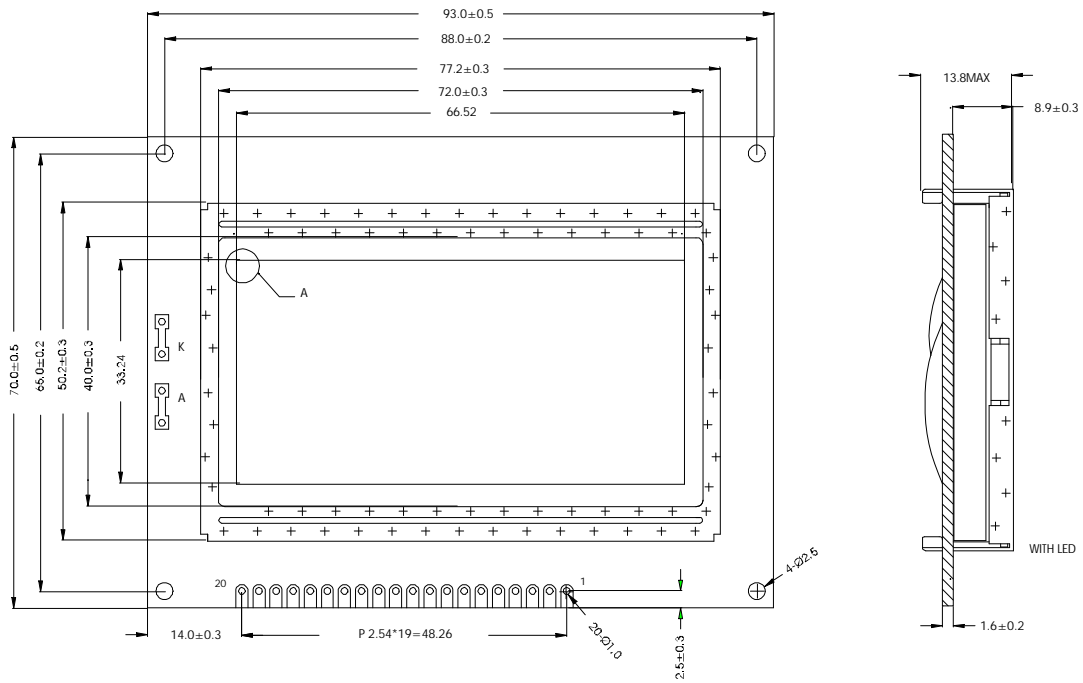

<p><b>HANTRONIX, INC.</b> 10080 BUBB RD. CUPERTINO, CA 95014</p>	<p>Q.A.: JK</p>	<p>REV.: 1.0</p>	<p><b>HDM64GS12-R</b></p>	<p>SHEET 13 OF 13 DATE: 9/3/03</p>
--	---------------------	----------------------	---------------------------	--