

液晶之友 电话: 020-33819057
http://www.lcdfriends.com

HANTRONIX

PRODUCT SPECIFICATION

HDM64GS12_-1

128X64 GRAPHICS
LCD DISPLAY MODULE

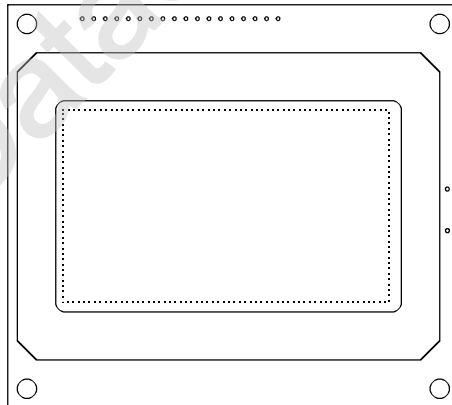

HANTRONIX, INC. 10080 BUBB RD. CUPERTINO, CA 95014	Q.A.:	REV.:	HDM64GS12_-1	SHEET 1 OF 18
	JK	2.1		DATE: 6/27/03

1. MECHANICAL DATA

(1) Product No. **HDM64GS12_-1**

(2) Module Size 78.0 (W)mm x 70.0 (H)mm x MAX9.5 (D)mm
(W/O,EL B/L)
78.0 (W)mm x 70.0 (H)mm x MAX13.0 (D)mm
(LED B/L)

(3) Dot Size 0.425(W)mm x 0.585(H)mm

(4) Dot Pitch 0.44 (W)mm x 0.60 (H)mm

(5) Number of Dots 128 (W) x 64 (H)Dots

(6) Duty 1/64

(7) LCD Display Mode STN: Gray Mode Yellow Mode Blue Mode
FSTN: Black and White(Normal White/Positive Image)
 Black and White(Normal Black/Negative Image)

Rear Polarizer: Reflective Transflective Transmissive

(8) Viewing Direction 6 O'clock 12 O'clock ___O'clock

(9) Backlight W/O LED EL

(10) Weight W/O B/L : 55 g
EL B/L : 58 g
LED B/L : 67 g

HANTRONIX, INC. 10080 BUBB RD. CUPERTINO, CA 95014	Q.A.:	REV.:	HDM64GS12_-1	SHEET 2 OF 18
	JK	2.1		DATE:

2. ABSOLUTE MAXIMUM RATINGS

(1) ELECTRICAL ABSOLUTE RATINGS

V_{SS}=0V

ITEM	SYMBOL	MIN	MAX	UNIT	COMMENT
Power Supply for Logic	VCC-VSS	-0.3	7.0	V	
Input Voltage	V _I	-0.3	VCC	V	
Static Electricity	-	-	-	-	Note 1

Note 1 LCM should be grounded during handling LCM.

(2) ENVIRONMENTAL ABSOLUTE MAXIMUM RATINGS

ITEM	NORMAL TEMP.				WIDE TEMP.			
	OPERATING		STORAGE		OPERATING		STORAGE	
	MIN.	MAX.	MIN.	MAX.	MIN.	MAX.	MIN.	MAX.
Ambient Temperature	0	50	-20	70	-20	70	-30	80
Humidity (Without Condensation)	Note 1,3		Note 2,3		Note 3,4		Note 3,5	

Note 1 Ta ≤ 50°C : 85%RH max
 Ta > 50°C : Absolute humidity must be lower
 than the humidity of 85%RH at 50°C

Note 2 Ta at -20°C will be < 48hrs, at 70°C will be < 120hrs

Note 3 Background color will change slightly depending on ambient temperature.
 This phenomenon is reversible.

Note 4 Ta ≤ 70°C : 75%RH max
 Ta > 70°C : Absolute humidity must be lower
 than the humidity of 75%RH at 70°C

Note 5 Ta at -30°C will be < 48hrs, at 80°C will be < 120hrs

HANTRONIX, INC. 10080 BUBB RD. CUPERTINO, CA 95014	Q.A.:	REV.:	HDM64GS12_-1	SHEET 3 OF 18
	JK	2.1		DATE:

3. ELECTRICAL CHARACTERISTICS

3-1. ELECTRICAL CHARACTERISTICS OF LCM

(VCC= 5V ± 10%)

ITEM		SYMBOL	CONDITION	MIN.	TYP.	MAX.	UNIT		
Input Voltage		V _{IH}	H level	0.8VCC	-	VCC	V		
		V _{IO}	L level	0	-	0.2VCC			
Recommended LCD Driving Voltage		VCC-V _O (V _{LCD}) Bias=1/10 Duty=1/64	-20℃	10.2	10.5	10.8	V		
			0℃	9.0	9.3	9.6			
			25℃	8.5	8.8	9.1			
			50℃	8.3	8.6	8.9			
			70℃	8.1	8.4	8.7			
Power Supply Current		I _{DD}	FLM=70Hz VCC = 5.0V VCC-V _O =8.8V PATTERN: □ ■ □ ■ □ ■ □ ■ □ ■ □ ■ □ ■	-	16.6	25.0	mA		
LCM	Surface Luminance (LED B/L)	L	V _{BL} = 4.2V _{DC}	PATTERN: (Dots All On)	H485C	-	4.5	-	cd/m ²
					S485C	-	4.0	-	
				PATTERN: (Dots All Off)	H485C	-	24.5	-	
					S485C	-	24.0	-	
LCM	Surface Luminance (EL B/L)	L	V _{BL} =110V _{AC} 400Hz	PATTERN: (Dots All On)	H485J	-	0.4	-	cd/m ²
					H485C	-	0.3	-	
				PATTERN: (Dots All Off)	H485J	-	2.4	-	
					H485C	-	2.5	-	

HANTRONIX, INC. 10080 BUBB RD. CUPERTINO, CA 95014	Q.A.:	REV.:	HDM64GS12_-1	SHEET 4 OF 18
	JK	2.1		DATE:

3-2.ELECTRICAL CHARACTERISTICS OF EL BACKLIGHT

Used EL Rating

Temp.=25°C

ITEM	SYMBOL	MIN.	TYP.	MAX.	UNIT	REMARK
Maximum applied voltage	V _L	-	-	170	Vrms	-
Maximum applied frequency	F _L	-	-	1000	Hz	-
EL current	I _L	-	5.4	6.2	mArms	at 110 Vrms 400 Hz
EL power consumption	P _L	-	0.6	-	W	(*1)
EL life time	L _L	-	2000	-	hrs	at 110 Vrms 400 Hz (*2)

(*1) Power consumption excluded inverter loss .

(*2) EL life time is defined as follows : The final brightness is at 50% of original brightness .

HANTRONIX, INC. 10080 BUBB RD. CUPERTINO, CA 95014	Q.A.: JK	REV.: 2.1	HDM64GS12_-1	SHEET 5 OF 18
				DATE: 6/27/03

3-3.ELECTRICAL CHARACTERISTICS OF BACKLIGHT

Used LED Rating

Temp.=25°C

ITEM	SYMBOL	MIN.	TYP.	MAX.	UNIT	REMARK
Peak forward current	I _P	-	-	550	mA	-
Maximum reverse voltage	V _R	-	-	8	V	-
Applied forward current	I _F	-	220	330	mA	at V _F = 4.2 V
Applied forward voltage	V _F	-	4.2	4.6	V	at I _F = 220 mA
LED power consumption	P _F	-	0.9	-	W	-
LED life time	LL	-	40000	-	hrs	at I _F = 220 mA (*1)

(*1) LED life time is defined as follows : The final brightness is at 50% of original brightness .

HANTRONIX, INC.
10080 BUBB RD.
CUPERTINO, CA 95014

Q.A.:

JK

REV.:

2.1

HDM64GS12_-1

SHEET 6 OF 18

DATE:

6/27/03

4.OPTICAL CHARACTERISTICS

AT Vop

ITEM		Cr(Contrast Ratio)										θ (Viewing Angle)		ϕ (Viewing Angle)	
		-20℃		0℃		25℃		50℃		70℃		25℃		25℃	
		MIN.	TYP.	MIN.	TYP.	MIN.	TYP.	MIN.	TYP.	MIN.	TYP.	MIN.	TYP.	MIN.	TYP.
H	J	7.0	7.5	8.0	8.5	11.0	11.5	12.0	12.5	8.0	8.5	-	82	-	±35
	C	6.0	6.5	7.0	7.5	8.0	8.5	9.0	9.5	7.0	7.5	-	67	-	±36
S	C	6.5	7.0	7.5	8.0	8.5	9.0	9.5	10.0	7.5	8.0	-	67	-	±36
R	C	2.5	3.5	2.5	3.5	3.5	4.5	2.5	3.5	2.5	3.5	-	65	-	±30
note		NOTE 6										NOTE 5			

note:

H: TRANSFLECTIVE(high transparency) C: YELLOW 6 O'clock
 R: Reflective J: NORMALLY WHITE(6 O'clock)
 S: Transflective

AT $\phi=0^\circ$ $\theta=0^\circ$

ITEM	SYMBOL	CONDITION	MIN.	TYP.	MAX.	UNIT	NOTE
Response Time (rise)	Tr	-20℃	-	2500	3000	ms	NOTE 2
		0℃	-	1500	2000		
		25℃	-	380	410		
		50℃	-	150	170		
		70℃	-	90	110		
Response Time (fall)	Tf	-20℃	-	1000	1500	ms	NOTE 2
		0℃	-	650	850		
		25℃	-	150	180		
		50℃	-	70	90		
		70℃	-	30	40		

HANTRONIX, INC. 10080 BUBB RD. CUPERTINO, CA 95014	Q.A.:	REV.:	HDM64GS12_-1	SHEET 7 OF 18
	JK	2.1		DATE:

(NOTE 1)

Definition of Operation Voltage(Vop)

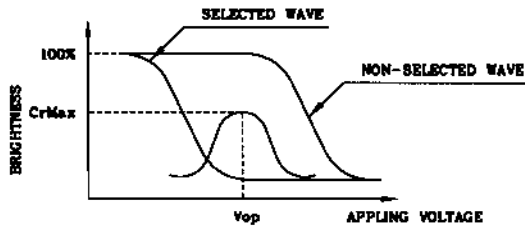

(positive type)

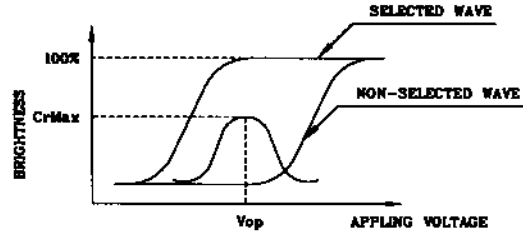

(negative type)

*Conditions

Viewing Angle : 0
 Frame Frequency : 70Hz
 Applying Waveform : 1/N duty 1/a bias

(NOTE 2)

Definition of Response Time(Tr,Tf)

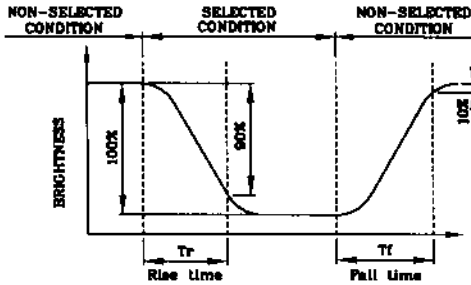

(positive type)

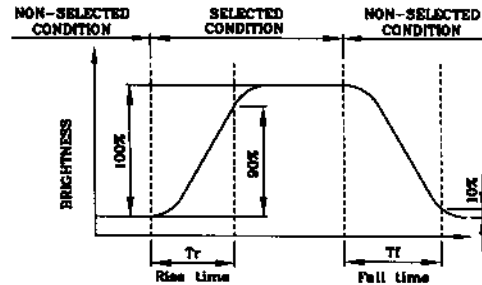

(negative type)

*Conditions

Operating Voltage : Vop
 Viewing Angle (θ,φ) : (0,0)
 Frame Frequency : 70Hz
 Applying Waveform : 1/N duty 1/a bias

(NOTE 3)

Description of Measuring Equipment and Driving Waveforms

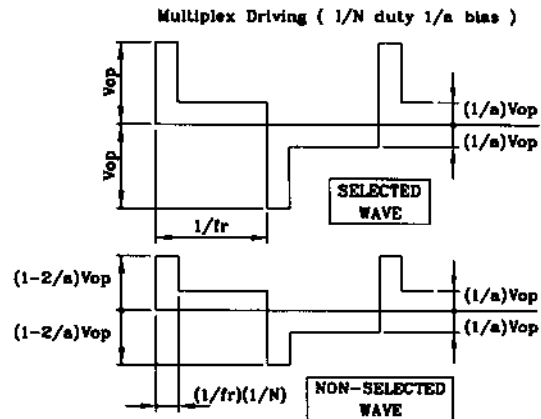
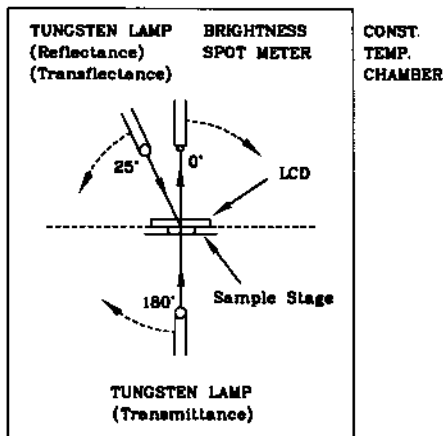

(NOTE 4)

Definition of Viewing Direction

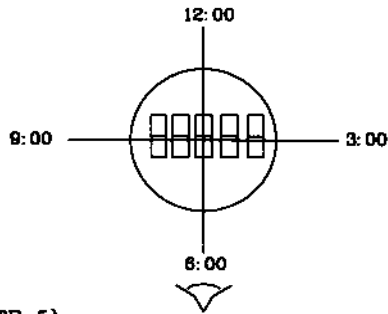

(NOTE 5)

Definition of Viewing Angle

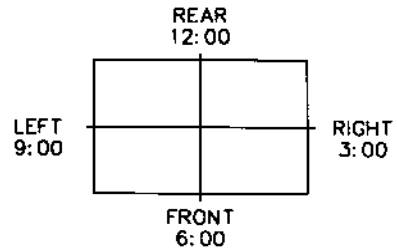
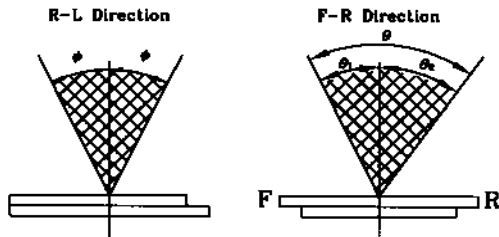

*For This Product
The Viewing Direction Is 6 O'clock
So $\theta_1 > \theta_2$

$$\theta = \theta_1 + \theta_2$$

*Conditions

Operating Voltage : V_{op}
Frame Frequency : 70Hz
Applying Waveform : 1/N duty 1/a bias
Contrast Ratio : larger than 2

(NOTE 6)

Definition of Contrast Ratio (Cr)

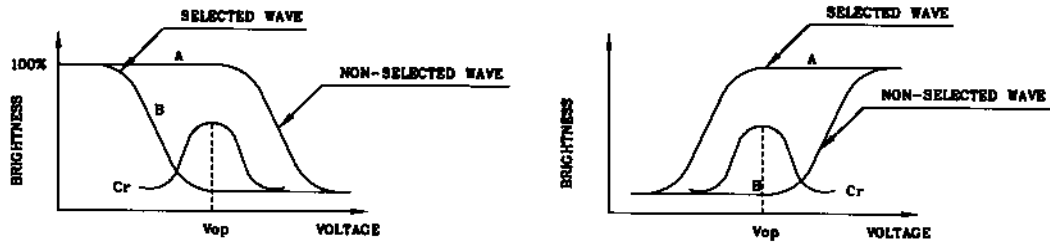

(positive type)

(negative type)

$$\text{Contrast Ratio} : Cr = A/B$$

*Conditions

Viewing Angle : 0
Frame Frequency : 70Hz
Applying Waveform : 1/N duty 1/a bias

HANTRONIX, INC.
10080 BUBB RD.
CUPERTINO, CA 95014

Q.A.:
JK

REV.:
2.1

HDM64GS12_-1

SHEET 9 OF 18

DATE:
6/27/03

5. BLOCK DIAGRAM

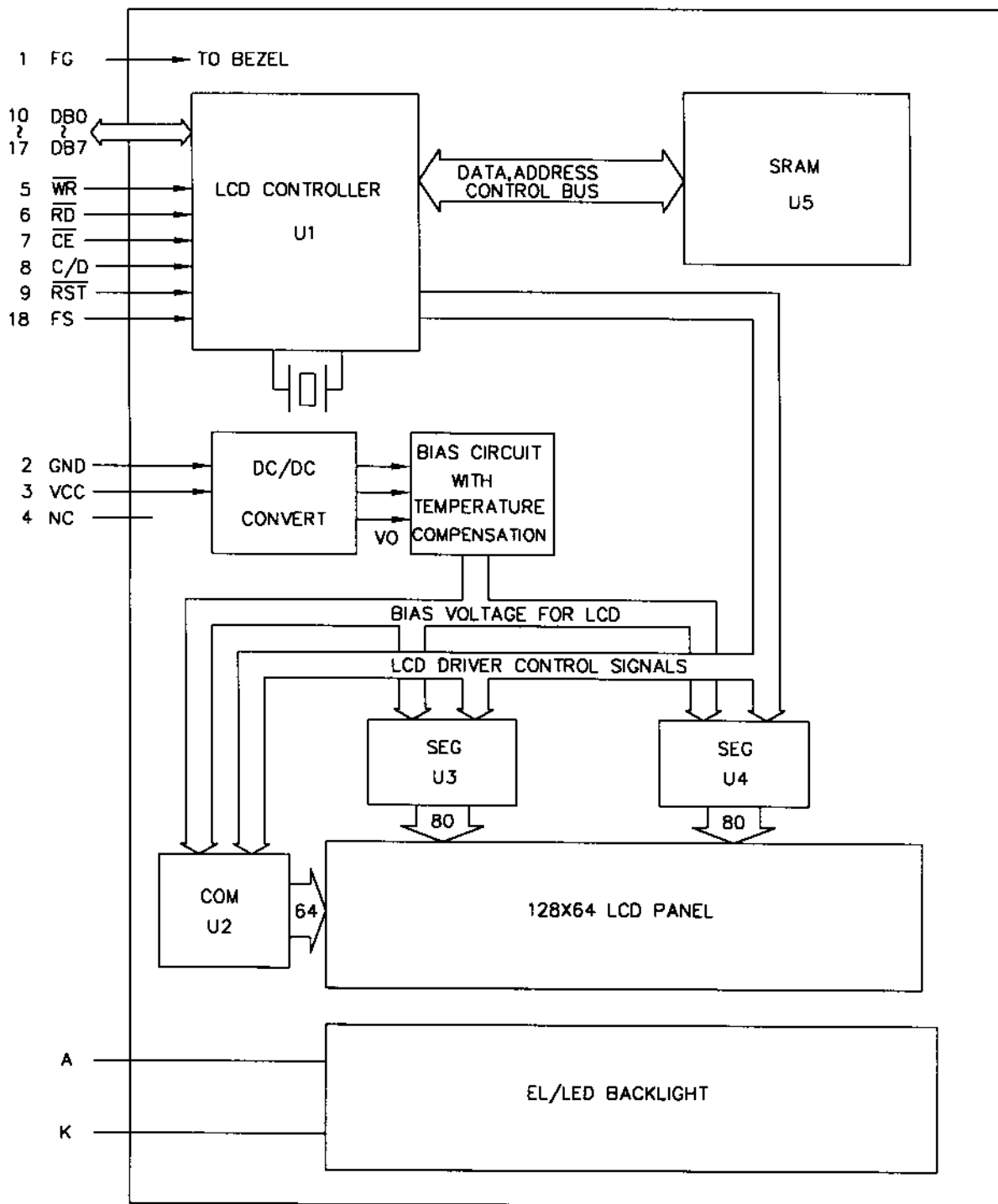

HANTRONIX, INC. 10080 BUBB RD. CUPERTINO, CA 95014	Q.A.:	REV.:	HDM64GS12_-1	SHEET 10 OF 18
	JK	2.1		DATE:

6. INTERNAL PIN CONNECTION

PIN NO.	SYMBOL	FUNCTION
1	FG	FRAME GROUND (0V)
2	GND	GROUND
3	VCC	POWER SUPPLY FOR LOGIC (+5V)
4	NC	NO CONNECT
5	\overline{WR}	DATA WRITE
6	\overline{RD}	DATA READ
7	\overline{CE}	CHIP ENABLE
8	C/D	\overline{WR} ="L",C/D="H" : COMMAND WRITE \overline{WR} ="L",C/D="L" : DATA WRITE \overline{RD} ="L",C/D="H" : STATUS READ \overline{RD} ="L",C/D="L" : DATA READ
9	\overline{RST}	CONTROLLER RESET
10	DB0	DATA INPUT/OUTPUT
11	DB1	DATA INPUT/OUTPUT
12	DB2	DATA INPUT/OUTPUT
13	DB3	DATA INPUT/OUTPUT
14	DB4	DATA INPUT/OUTPUT
15	DB5	DATA INPUT/OUTPUT
16	DB6	DATA INPUT/OUTPUT
17	DB7	DATA INPUT/OUTPUT
18	FS	FONT SELECT CONNECT TO VDD : 6X8 PIXELS/CHARACTER CONNECT TO GND : 8X8 PIXELS/CHARACTER
A	A	ANODE OF BACKLIGHT
K	K	CATHODE OF BACKLIGHT

HANTRONIX, INC. 10080 BUBB RD. CUPERTINO, CA 95014	Q.A.:	REV.:	HDM64GS12_-1	SHEET 11 OF 18
	JK	2.1		DATE:

7. POWER SUPPLY

LCM

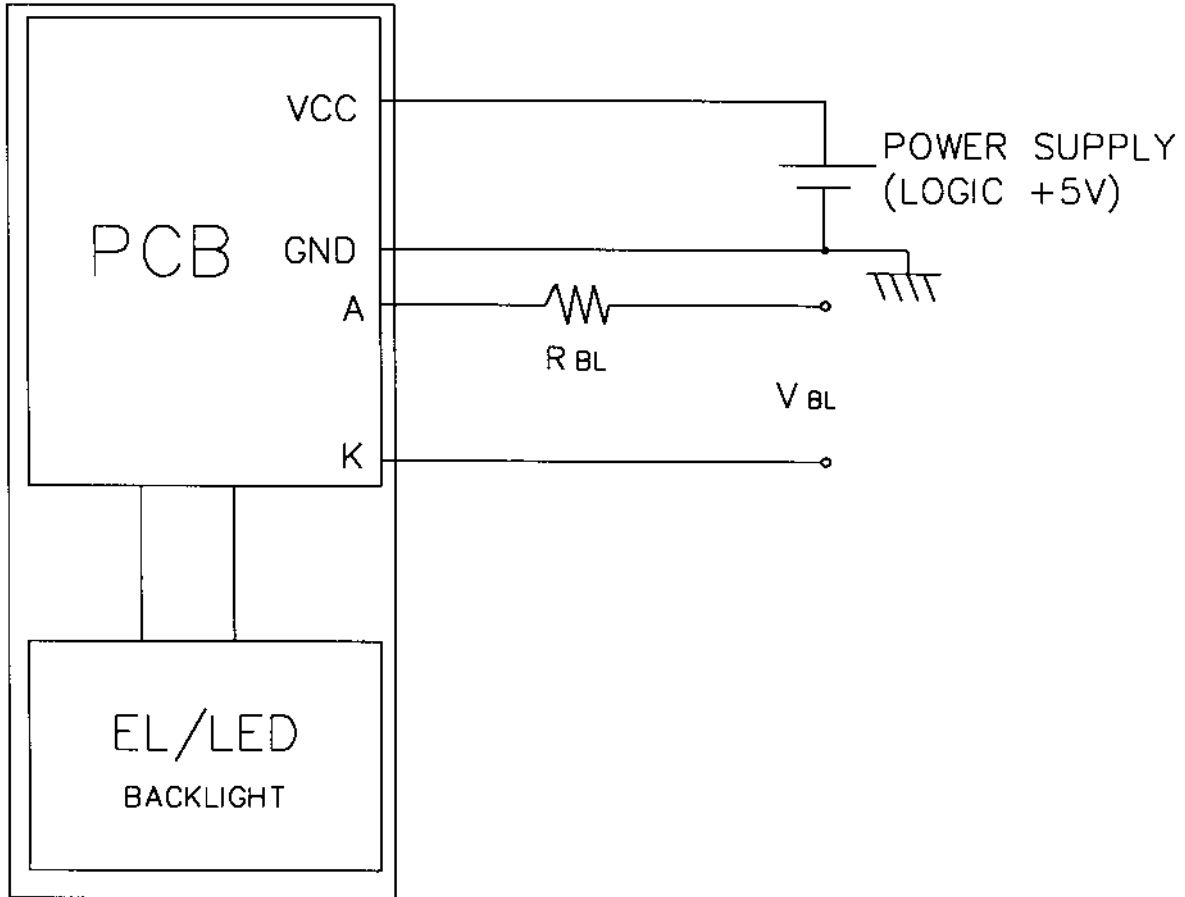

Recommended Value for R_{BL} and V_{BL}

ITEM Back Light	R _{BL}		V _{BL}	
	LED	EL	LED	EL
Interface				
A,K PIN	5Ω	0Ω	5V _{Dc}	110 Vac 400Hz

HANTRONIX, INC.
10080 BUBB RD.
CUPERTINO, CA 95014

Q.A.:
JK

REV.:
2.1

HDM64GS12_-1

SHEET 12 OF 18

DATE:
6/27/03

8-1. INTERFACE TIMING CHARACTERISTICS

ITEM	ITEM	CONDITION	MIN.	MAX.	UNIT
C/D SET UP TIME	t_{CDS}	Fig.	100	-	ns
C/D HOLD TIME	t_{CDH}	Fig.	10	-	ns
$\overline{CE}, \overline{RD}, \overline{WR}$ CLOCK WIDTH	t_{CP}, t_{RP}, t_{WP}	Fig.	80	-	ns
DATA SET UP TIME	t_{DS}	Fig.	80	-	ns
DATA HOLD TIME	t_{DH}	Fig.	40	-	ns
ACCESS TIME	t_{ACC}	Fig.	-	150	ns
DATA OUTPUT HOLD TIME	t_{OH}	Fig.	10	50	ns

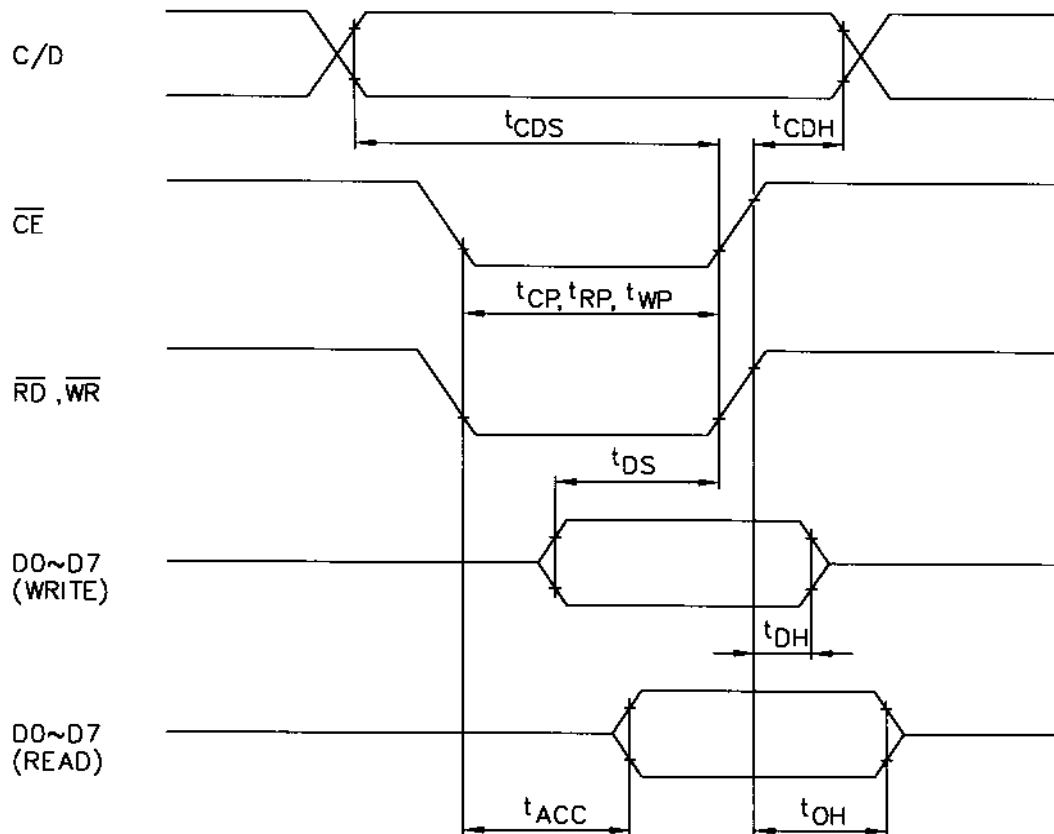
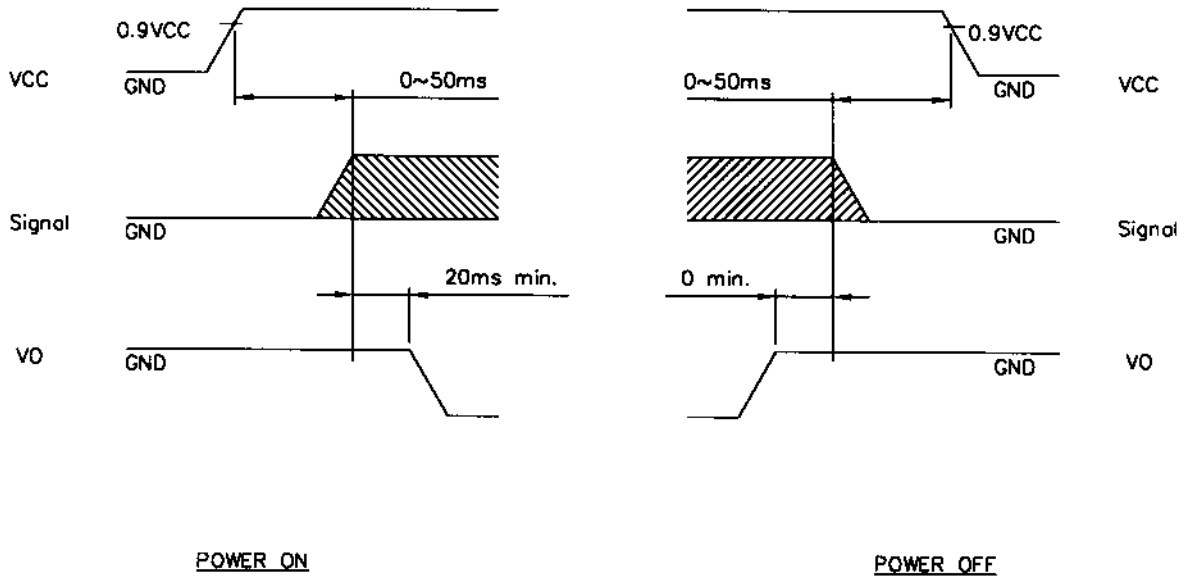

Fig. INTERFACE TIMING CHART

HANTRONIX, INC. 10080 BUBB RD. CUPERTINO, CA 95014	Q.A.:	REV.:	HDM64GS12_-1	SHEET 13 OF 18
	JK	2.1		DATE:

8-2. POWER ON/OFF TIMING CHARACTERISTICS



The missing pixels may occur when the LCM is driven beyond above power interface timing sequence.

HANTRONIX, INC. 10080 BUBB RD. CUPERTINO, CA 95014	Q.A.:	REV.:	HDM64GS12_-1	SHEET 14 OF 18
	JK	2.1		DATE:

8-3.DISPLAY PATTERN

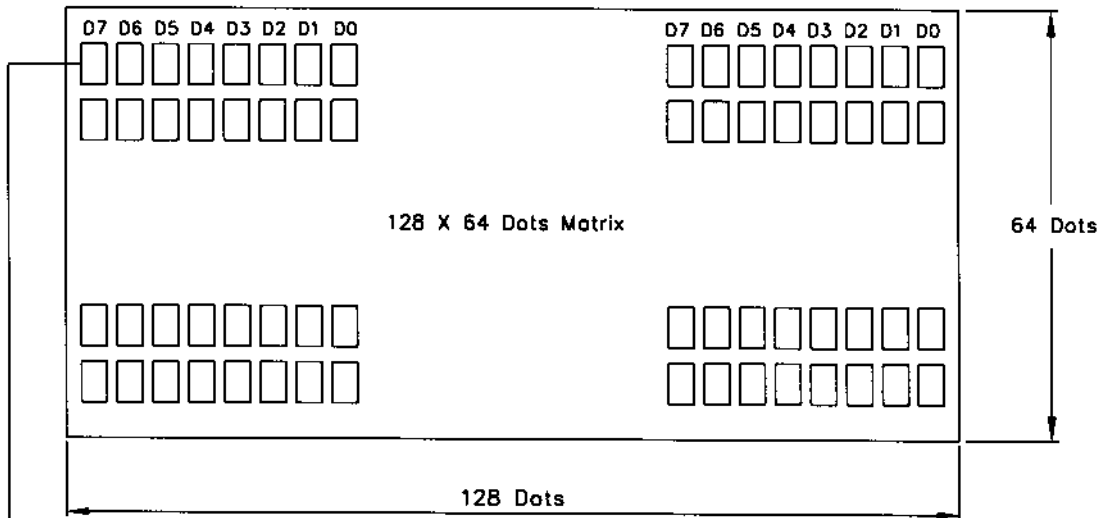

Starting dot for the starting address of display RAM.

D0~D7 are 8 bits transmitted data ,where D0 is LSB and D7 is MSB.

HANTRONIX, INC. 10080 BUBB RD. CUPERTINO, CA 95014	Q.A.:	REV.:	HDM64GS12_-1	SHEET 15 OF 18
	JK	2.1		DATE: 6/27/03

9. RELIABILITY TEST

NO	ITEM	CONDITION			STANDARD	NOTE
1	High Temp. Storage	70°C	120HR		Appearance without defect	
2	Low Temp. Storage	-20°C	120HR		Appearance without defect	
3	High Temp. & High Humi. Storage	40°C 90%RH	120HR		Appearance without defect	
4	Thermal Shock	-20°C, 30min → 25°C, 5min → 70°C, 30min → 25°C, 5min (1cycle)			Appearance without defect	5 cycles

HANTRONIX, INC.
10080 BUBB RD.
CUPERTINO, CA 95014

Q.A.:

JK

REV.:

2.1

HDM64GS12_-1

SHEET 16 OF 18

DATE:

6/27/03

NOTICE:

• SAFETY

- 1.If the LCD panel breaks, be careful not to get the liquid crystal to touch your skin.
- 2.If the liquid crystal touches your skin or clothes, please wash it off immediately by using soap and water.

• HANDLING

- 1.Avoid static electricity which can damage the CMOS LSI.
- 2.Do not remove the panel or frame from the module.
- 3.The polarizing plate of the display is very fragile. So, please handle it very carefully.
- 4.Do not wipe the polarizing plate with a dry cloth, as it may easily scratch the surface of plate.
- 5.Do not use ketonics solvent & Aromatic solvent, use with a soft cloth soaked with a cleaning naphtha solvent.

• STORAGE

- 1.Store the panel or module in a dark place where the temperature is $25^{\circ}\text{C}\pm 5^{\circ}\text{C}$ and the humidity is below 65% RH.
- 2.Do not place the module near organics solvents or corrosive gases.
- 3.Do not crush, shake, or jolt the module.

• TERMS OF WARRANT

- 1.Acceptance inspection period
The period is within one month after the arrival of contracted commodity at the buyer's factory site.
- 2.Applicable warrant period
The period is within twelve months since the date of shipping out under normal using and storage conditions.

HANTRONIX, INC. 10080 BUBB RD. CUPERTINO, CA 95014	Q.A.: JK	REV.: 2.1	HDM64GS12_-1	SHEET 17 OF 18
				DATE: 6/27/03

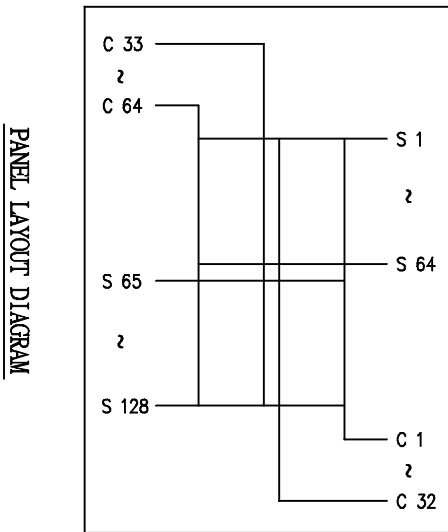
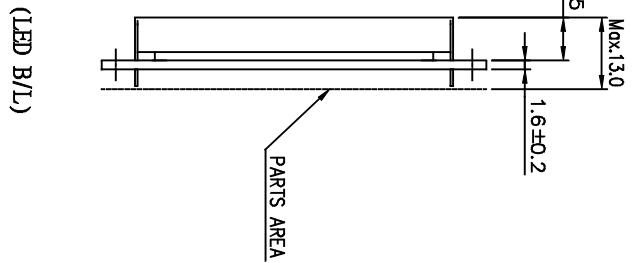
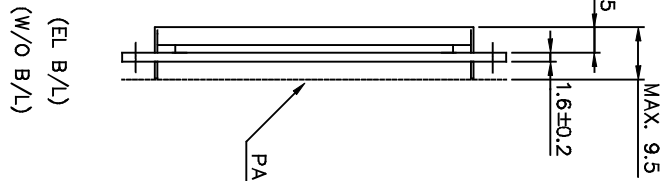
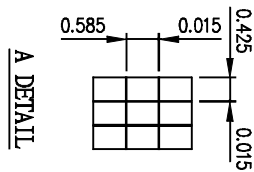
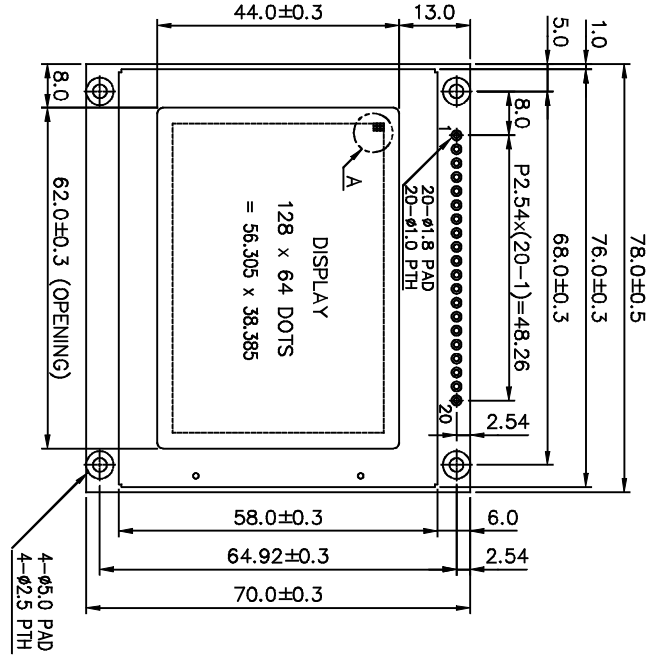
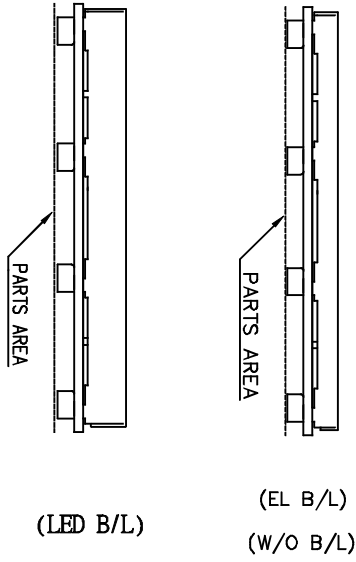

PANEL LAYOUT DIAGRAM

HANTRONIX, INC.
10080 BUBB RD.
CUPERTINO, CA 95014

Q.A.:
JK

REV.:
2.1

HDM64GS12_-1

SHEET 18 OF 18

DATE:
6/27/03