

# HE 8 / 127 Series

Connectors for PCB

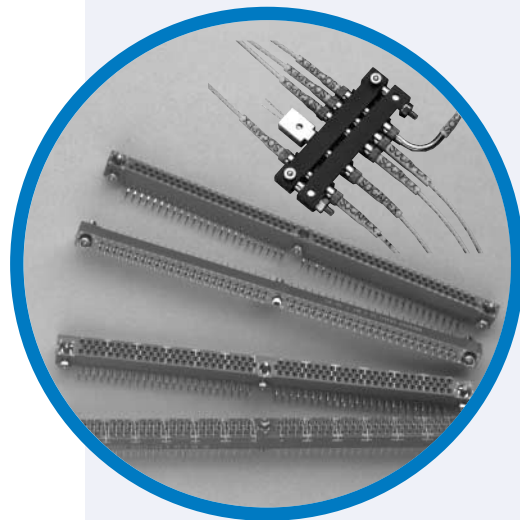

MAIN CHARACTERISTICS

**Main features**

The 127 series circuit board connectors are available in 3 different versions:

- HE 801 / 127: From 17 to 144 signal contacts, on 2 or 3 rows  
Pin contacts with round sections
- HE 804 / 127: From 17 to 144 signal contacts, on 2 or 3 rows  
Pin contacts with rectangular sections
- HE 807 / 127H: From 5 to 84 signal contacts and 3 to 10 size 16 cavities for power, coaxial contacts or optical termini  
Pin contacts with round sections

Version	Insert height (mm)	Pin signal contacts	
		Shape	Section (mm <sup>2</sup> )
HE 801	7.9	round, stamped	0.28
HE 804	6.9	rectangular, cut-out	0.48
HE 807	7.9	round, stamped	0.28

- Gold plating in accordance with NFC 93480: mini 0.8 µm Au
- Flexibility: 16 types of contacts, 25 types of fittings and 29 insert versions
- Crimp pin and socket contacts
- Repairability: possibility to change the contacts one by one
- Density: up to 144 contacts within 150 mm long inserts

**Technical characteristics**

Temperature range	- 55°C / + 125°C (during 56 days)
Durability: - HE 801 & HE 804 - HE 807	500 cycles 250 cycles
Insulation resistance	≥ 5000 MΩ
Salt spray	96 hours
Vibrations	2000/10 g
Electrical discontinuities	≤ 1µs
Shocks: - HE 801 & HE 804 - HE 807	100 g 50 g
Rating voltage at 50 Hz	250 Vrms
Test voltage at sea level	1000 Vrms
Test current	see curve

- Contact resistance ≤ 12 mΩ
- Capacitance between contacts ≤ 5 pF
- Mating/unmating force per contact:**
- HE 801 0.14 N ≤ F ≤ 0.90 N
  - HE 804 0.14 N ≤ F ≤ 1.60 N  
0.14 N ≤ F ≤ 0.90 N (144 contacts)
  - HE 807 0.14 N ≤ F ≤ 1.60 N  
0.14 N ≤ F ≤ 0.90 N (84 + 10 contacts)  
1 N ≤ F ≤ 15 N (coaxial contacts)

- Contact retention in the insert:**
- HE 801 20 N for W contact
  - HE 804 & HE 807 20 N for S, W and Z contacts

- Torque values:**
- nut for Ø 2.5 mm screw, brass 0.25 mN
  - nut for Ø 1.6 mm screw, brass 0.15 mN

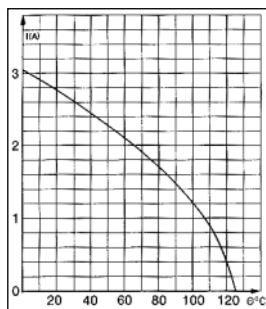

DESCRIPTION

The 127 series circuit board connectors are in accordance with several standards: NFC UTE 93424 (HE801, HE804 and HE807), BS9525 (-N0001, -F0006 and -F0007), MIL-C-55302 (140 to 155) and CEI130-16.

The 127 series use a 1.27 mm staggered pitch with 2.54 mm between the rows.

Different versions are available, from 17 to 144 contacts, with different terminations: straight, right angled, crimp, solder, SMT and wire-wrap. Mixed layout styles exist, providing the addition of 3 to 10 cavities accepting either power or coaxial contacts as well as optical termini.

*Low profile rectangular PCB connectors*

APPLICATIONS

- Ground military and aircraft applications
- Telecom applications
- Avionics applications

The 127 series connectors are used among others in the Mirage, Rafale and Leclerc programs

HE8 / 127



**Amphenol**

# Arrangements

127 H – HE 807 Series				Dimensions (mm)		127 – HE 801 / HE 804 Series	
Mating side view of plug	Contacts		A	B	□	□	
	□	⊠					
	▲	5	3	37.7	30.5	17	●
	▲●	17	3	52.9	45.7	29	●
		5	6				
		0	7				
		0	8	58	50,8	33	●
	▲●	29	3	68.2	60.9	41	●
	▲●	17	6	83.4	76.2	53	●
	▲●	41	3				
		29	6				
	▲●	53	3	98.7	91.4	65	●
	●	41	6	113.9	106.7	72	●
	▲	60	3				
		48	6				
	▲●	72	3	129.1	121.9	84	●
	▲●	60	6	144.4	137.1	96	●
	▲●	84	3				
	●	72	6				
		56	10	83.4	76.2	80	●
<b>2 rows:</b> e = 6.3 mm	<b>3 rows:</b> 80 cts: e = 8.94 mm max 144 cts: e = 8.55 mm max						

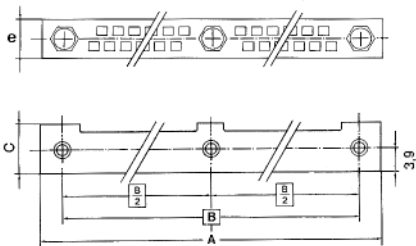

C = 6.8 mm (HE 804) C = 7.8 mm (HE 801-807)

- signal contacts
- ⊠ special contacts
- ▲ asymmetrical arrangements
- crimp contacts possibility

## Contacts & fittings

Type	Socket contacts	Fittings compatible with socket contacts			Fittings (HE standard)		Fittings compatible with pin contacts			Pin contacts	Type	Installation
		127 2 rows	127 T 3 rows	127 H	801 807	804	127 2 rows	127 T 3 rows	127 H			
YC		A	A	A	101	101	J		A		YC	
YL*		D	D	D	103	103	S		D		YL*	
T		AS	AS	AS	124	124	JS		AS			
		KE		KE	208	209	AE		KE			
		KED		KED	224	223	AED		KED			
		KET		KET	425	425	AET		KET			
		PA	PA	PA	102	102	PC		PA			
U		H			115	107					U	
		N			116	108	N					
		NF			126	126	NF					
		NS			114	104	NS					
		V					V					
YD		L				228					Y	
Y				P	226							
		K		K	212	201	A	A	P			
		P			203	203	B	B	K			
W3		KD		KD	221	221	AD	AD	KD			
		KY		KT	422	422	AT	AT	KT			
		E		E	117	110	R	R	E			
Z		EF		EF	119	112	RF	RF	EF			
		ES		ES	125	125	RS	RS	ES			
		ET		ET	327	327	RT	RT	ET			
		T		T	118	11	T	D	T			
X1		S		S	219	220	D	D	S			
		SC		IE	213	206	DC					
					206							

→ Contact removal direction

\* X and XL connectors + HE8C101, 102, 103 or 124 fixing accessories + longer screw (P/N 44322) for 3.2 mm PCB

## Tooling









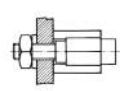

REMOVAL TOOLS								
Pin contacts	Removal direction	Tool	Socket contacts	Removal direction	Tool	Socket contacts	Removal direction	Tool
ZC-X-YC-YL	rear	1272	YC-U-Z-X1 (HE801-804)	rear	1271	W3 Y-YD	front	20973 20143
Y-W3-U	front	24098	YC-U-Z-X1 (HE807)	rear	24099	HE807 particular contacts	rear	23550

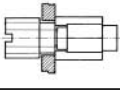
CRIMPING TOOLS						
Pin contacts	AWG	Tool	Socket	AWG	Tool	Turret
X	26 to 22	HE 8 20 051*	X1	26 to 22	809801 (M22520/2-01)	127.800 030

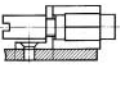
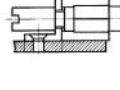
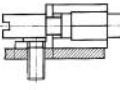
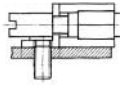
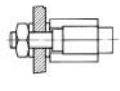
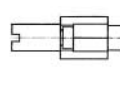
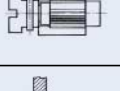

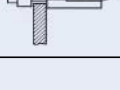

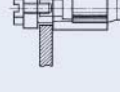
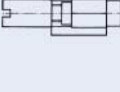
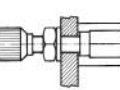
\* No additional turret

HE	Fittings				◆ Recommended	HE8C P/N	Central fittings	Contacts		Description
	for contacts socket		pin					S	P	
	127	HE8C	127	HE8C						
804	A	101	J	101	◆	102		T	Codable. Unlockable Daughter board FREE PLUG	
801	A	101	J	101		102		YC		YC
807	A	101	A	101		102		YL		YL
804	PA	102	PC	102	◆	102		T	Uncodable. Unlockable Daughter or extension board FREE PLUG	
801	PA	102	PC	102		102		YC		YC
807	PA	102	PA	102		102		YL		YL
804	H	107			◆	105		U	U	Codable. Unlockable. Surface mounting daughter board offset from centerline, FREE PLUG
804	N	106	N	106	◆	104		U	U	Codable. Unlockable. Surface mounting daughter board aligned with centerline, FREE PLUG
801	N	115	N	115		114				
804	V	104	V	104	◆	104		U	U	Codable. Unlockable Daughter board aligned with centerline, FREE PLUG
801	V	114	V	114		114				
804	E	110	R	110	◆	113		W3	W3	Codable. Unlockable For chassis or mother board (board/board, board/chassis)
801	E	117	R	117		129		Z,Y	ZC	
807	E	117	E	117		129		YD,X1	Y,X	
804	T	111	T	111	◆	113		W3	W3	Uncodable Unlockable
801	T	118	T	118		129		Z,Y	ZC	
807	T	118	T	118		129		YD,X1	Y,X	
804	D	103	S	103	◆	102		T	Uncodable Lockable on receptacle side Daughter board FREE PLUG	
801	D	103	S	103		102		YC		YC
807	D	103	D	103		102		YL		YL
804	NF	108	NF	108	◆	104		U	U	Lockable on receptacle side Surface mounting daughter board aligned with centerline
801	NF	116	NF	11		114				
804	EF	112	RF	112	◆	113		W3	W3	Uncodable Lockable on receptacle side For chassis or mother board
801	EF	119	RF	119		129		Z,Y	ZC	
807	EF	119	EF	119		129		YD,X1	Y,X	
804	AS	124	JS	124	◆	102		T	Codable Lockable on receptacle side Daughter board FREE PLUG	
801	AS	124	JS	124		102		YC		YC
807	AS	124	AS	124		102		YL		YL
804	NS	126	NS	126	◆	104		U	U	Codable. Lockable on receptacle side. Surface mounting daughter board aligned with centerline
801	NS		NS			114				
804	ES	125	RS	125	◆	113		W3	W3	Codable Lockable on receptacle side For chassis or mother board
801	ES	125	RS	125		129		Z,Y	ZC	
807	ES	125	ES	125		129		YD,X1	Y,X	
804	ET	327	RT	327	◆	313		W3	W3	Codable Quarter turn lockable Cable/card or cable/chassis
801	ET	327	RT	327		329		Z	ZC	
807	ET	327	ET	327		329		X1	X	

# FOR A CONNECTOR'S MATING PAIR Receptacles – female fittings

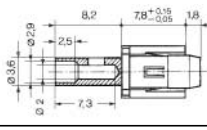
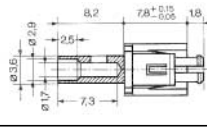
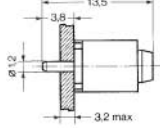
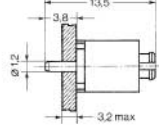
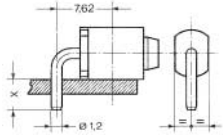
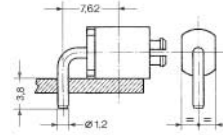
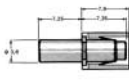
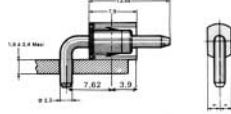
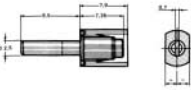
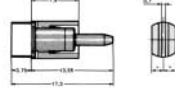
HE	Fittings				HE8C P/N	Central fittings	Contacts		Description	
	for contacts socket		pin				Recommended	S		P
	127	HE8C	127	HE8C						
804	K	201	A	201	◆ 		W3	W3	Codable. Unlockable For chassis or mother board FIXED RECEPTACLE	
801	K	212	A	212			Z,Y	ZC		
807	K	212	K	212			YD,X1	Y,X		
804	P	203	B	203	◆ 		W3	W3	Codable. Unlockable For chassis FLOATING RECEPTACLE	
801	P	203	B	203			Z,Y	ZC		
807	P	226	P	226			YD	Y		
804	KE	209	AE	209	◆ 		T	YC	Codable. Unlockable Daughter board or board to board mating FREE RECEPTACLE	
801	KE	208	AE	208			YL	YL		
807	KE	208	KE	208			T	U		
804	L	228			◆ 		W3	W3	Codable. Unlockable for chassis or mother board with insulating washer	
804	S	220	D	220			Z,Y	ZC		
801	S	219	D	219			YD,X1	Y,X		
804	SC	207	DC	207	◆ 		X1	X	Uncodable. Locking device-extractor for cables FREE RECEPTACLE for flex	
804	SC	213	DC	213			Y	Y		
807	S	213	S	213			W3	W3		
804	KD	221	AD	221	◆ 		W3	W3	Uncodable. Locking device-extractor for chassis FLOATING RECEPTACLE	
801	KD	221	AD	221			Z,Y	ZC		
807	KD	221	KD	221			X1	Y,X		
804	KED	223	AED	223	◆ 		YC	YC	Codable. Locking by a central captive screw + screw-head retaining after locking, ensuring resistance to vibrations. For daughter board or board to board mating. FREE RECEPTACLE	
801	KED	224	AED	224			T	YL		
807	KED	224	KED	224			YC	YL		
804	KT	422	AT	422	◆ 		W3,Z	W3,X	Codable. Quarter turn locking For chassis or mother board FIXED RECEPTACLE	
801	KT	422	AT	422			X1	ZC		
807	KT	422	KT	422			YD	Y		
804	KET	425	AET	425	◆ 		T	YC	Codable. Quarter turn locking. For daughter board or board to board mating FREE RECEPTACLE	
801	KET	425	AET	425			YC	YL		
807	KET	425	KET	425			YL	YL		

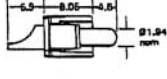
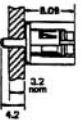
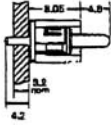
## Power, coaxial and optical contacts for HE 807 / 127 H connectors

POWER CONTACTS					
Socket	P/N			P/N	Pin
<b>Current rating 10 A</b>					
	F121	<ul style="list-style-type: none"> <li>- straight</li> <li>- for hard soldering on wire</li> <li>- suitable for wire diameter up to 2 mm</li> </ul>		M121	
	F141	<ul style="list-style-type: none"> <li>- straight</li> <li>- for hard soldering on mother board</li> <li>- suitable for board max 3.2 mm thick</li> </ul>		M141	
	F132	<ul style="list-style-type: none"> <li>- right angled</li> <li>- for hard soldering on daughter board</li> <li>- suitable for thickness board from 1.6 to 2.4 mm</li> </ul>		M132	
<b>Current rating 20 A</b>					
	F124	<ul style="list-style-type: none"> <li>- straight</li> <li>- for hard soldering on wire</li> <li>- suitable for wire diameter up to 2 mm</li> </ul>	<ul style="list-style-type: none"> <li>- right angled</li> <li>- for hard soldering on daughter board</li> </ul>	M134	
	F164	<ul style="list-style-type: none"> <li>- straight</li> <li>- for mother board or bus bar</li> </ul>	<ul style="list-style-type: none"> <li>- straight</li> <li>- for bus bar</li> </ul>	M164	
	FH1	<ul style="list-style-type: none"> <li>- straight</li> <li>- for hard soldering on wire</li> <li>- suitable for wire diameter up to 1.83 mm</li> </ul>		MH1	
	FH2	<ul style="list-style-type: none"> <li>- straight</li> <li>- for hard soldering on mother board</li> <li>- suitable for thickness board 3.2 mm max.</li> </ul>		MH2	
	FH3	<ul style="list-style-type: none"> <li>- right angled</li> <li>- for hard soldering on daughter board</li> <li>- suitable for thickness board from 1.6 to 2.4 mm</li> </ul>		MH3	

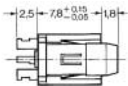
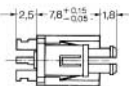
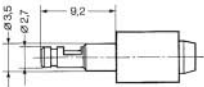
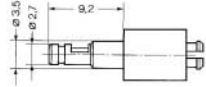
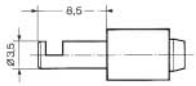
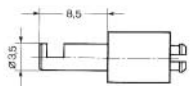
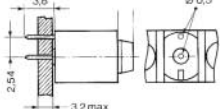
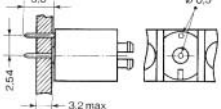
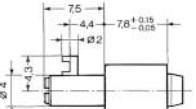
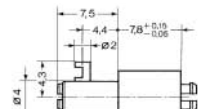
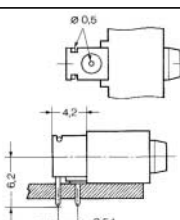
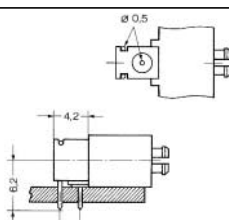
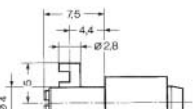
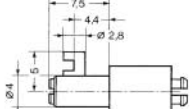
COAXIAL CONTACTS																				
Socket	P/N		P/N	Pin																
	F011	- straight - for hard soldering on flexible cable	M011																	
	F021	- straight - for hard soldering on flexible cable - suitable for wire of max 2 mm outer diameter (KX 21 A / RG 178 B/U)	M021																	
	F061	- straight - for hard soldering on semi-rigid cable - suitable for wire of max 2.16 mm outer diameter (KS 1 / RG 405 U)	M061																	
	F041	- straight - for hard soldering on mother board	M041																	
	F012	- right angled - for hard soldering on flexible cable - suitable for wire outer diameter up to 2 mm (KX 21 A / RG 178 B/U)	M012																	
	F032	- right angled - for hard soldering on daughter board - suitable for thickness board from 1.6 to 2.4 mm	M032																	
	F052	- right angled - for hard soldering on semi-rigid cable - suitable for wire outer diameter up to 2.16 mm (KS 1 / RG 405 U)	M052																	
<p><b>Technical characteristics</b></p> <table border="0"> <tr> <td>Impedance .....</td> <td>50 Ω</td> <td>Frequency range .....</td> <td>0 to 1 GHz</td> </tr> <tr> <td>Voltage rating .....</td> <td>180 V</td> <td>Contact resistance .....</td> <td>≤ 12 mΩ</td> </tr> <tr> <td>Current rating .....</td> <td>500 mA</td> <td>VSWR at 1 GHz .....</td> <td>1.3 max.</td> </tr> <tr> <td>Contact retention .....</td> <td>≥ 50 N</td> <td>Insertion and extraction force per contact .....</td> <td>1 N ≤ F ≤ 15 N</td> </tr> </table>					Impedance .....	50 Ω	Frequency range .....	0 to 1 GHz	Voltage rating .....	180 V	Contact resistance .....	≤ 12 mΩ	Current rating .....	500 mA	VSWR at 1 GHz .....	1.3 max.	Contact retention .....	≥ 50 N	Insertion and extraction force per contact .....	1 N ≤ F ≤ 15 N
Impedance .....	50 Ω	Frequency range .....	0 to 1 GHz																	
Voltage rating .....	180 V	Contact resistance .....	≤ 12 mΩ																	
Current rating .....	500 mA	VSWR at 1 GHz .....	1.3 max.																	
Contact retention .....	≥ 50 N	Insertion and extraction force per contact .....	1 N ≤ F ≤ 15 N																	

## Power, coaxial and optical contacts for HE 807 / 127 H connectors

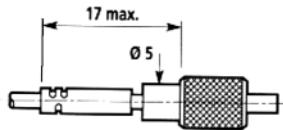
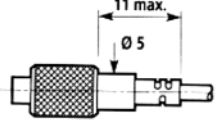
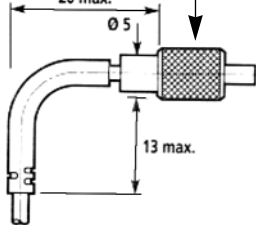
OPTICAL TERMINI			
<p><b>Straight pin</b></p> 	<p><b>Straight socket</b></p> 		
<p><b>Angled pin</b></p> 	<p style="text-align: center;">Insert</p> <p style="text-align: center;">Insert</p>		
<p>Dimensions in mm</p>			
<p><b>Technical characteristics</b></p> <table style="width: 100%; border: none;"> <tr> <td style="width: 50%; border: none;"> <p>Fiber type.....50/125, 62.5/125 and 100/140 μm</p> <p>Cable type.....Ø 1.5 mm airborne tight jacket cable equipped with 100/140/500 μm fiber</p> <p>Material .....- metallic body - ceramic ferrule - ceramic alignment sleeve</p> </td> <td style="width: 50%; border: none;"> <p>Insertion loss.....0.5 dB (with 100/140 μm fibers)</p> <p>Durability.....250 cycles</p> <p>Temperature range.....- 55°C / + 125 °C</p> <p>Cable retention by crimping.....&gt; 10 daN</p> </td> </tr> </table>		<p>Fiber type.....50/125, 62.5/125 and 100/140 μm</p> <p>Cable type.....Ø 1.5 mm airborne tight jacket cable equipped with 100/140/500 μm fiber</p> <p>Material .....- metallic body - ceramic ferrule - ceramic alignment sleeve</p>	<p>Insertion loss.....0.5 dB (with 100/140 μm fibers)</p> <p>Durability.....250 cycles</p> <p>Temperature range.....- 55°C / + 125 °C</p> <p>Cable retention by crimping.....&gt; 10 daN</p>
<p>Fiber type.....50/125, 62.5/125 and 100/140 μm</p> <p>Cable type.....Ø 1.5 mm airborne tight jacket cable equipped with 100/140/500 μm fiber</p> <p>Material .....- metallic body - ceramic ferrule - ceramic alignment sleeve</p>	<p>Insertion loss.....0.5 dB (with 100/140 μm fibers)</p> <p>Durability.....250 cycles</p> <p>Temperature range.....- 55°C / + 125 °C</p> <p>Cable retention by crimping.....&gt; 10 daN</p>		

### How to order

<b>Series (2 rows)</b>	<b>127</b>	<b>MD</b>	<b>16</b>	<b>C</b>	<b>A1</b>	<b>15</b>	<b>CO</b>
<b>Contact type</b>							
MD: Straight pin							
MC: Angled pin							
FD: Straight socket							
<b>Contact size</b>							
<b>Ceramic ferrule</b>							
<b>Cable type</b>							
A1: 50/62.5/125/500 μm							
C1: 100/140 μm							
<b>Cable code</b>							
15: cable Ø 1.5 mm							
For other cables, please consult us							
<b>Obligatory suffix</b>							

For installation instructions, please consult us.



# Panel and printed circuit board drilling for HE 801 – HE 804 / 127 connectors

## Panel drilling

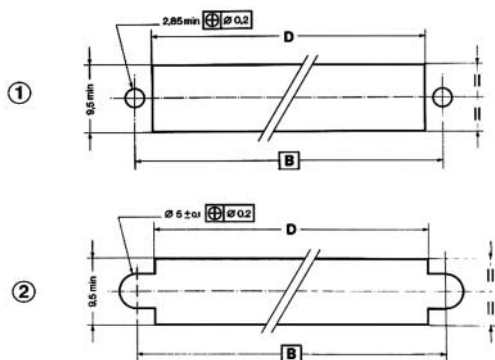

	Receptacles		Plugs	
	Fittings	Contacts	Fittings	Contacts
Fig. 1	A-AD-AT	Pin W3-ZC-X	R-RF-RS-T	Pin W3-ZC-X
	K-KD-KT-L	Socket W3-Z	E-EF-ES-T	Socket W3-Z
Fig. 2	B	Pin W3-ZC-X		
	P	Socket W3-Z		

## Printed circuit board drilling

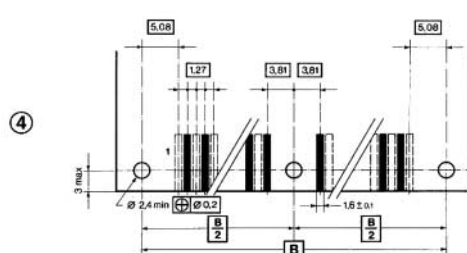
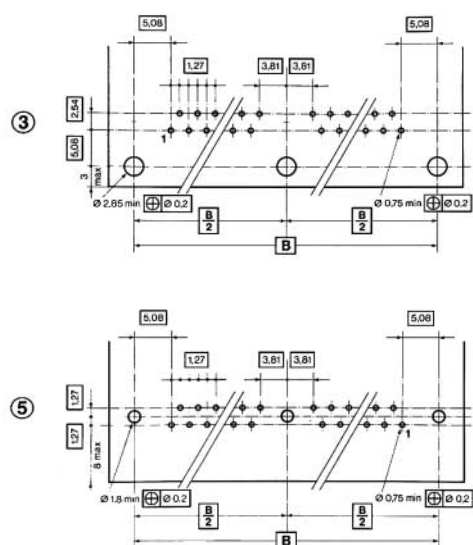

	Daughterboard drilling for:			
	Receptacles		Plugs	
	Fittings	Contacts	Fittings	Contacts
Fig. 3	KET AET	YC	A-D-AS-PA J-S-JS-PC	YC
Fig. 4			H-N-NF NS-V	U
Fig. 5	KE-KED AE-AED	YC		

### Note:

The boards are illustrated from the connector side

The figures show the drilling of PC boards with connectors equipped with central guides (72, 84 and 96 contacts).

For smaller connectors (17, 29, 33, 41, 53 and 65 contacts), ignore the central drilling.

All contacts outputs are equidistant.

For daughterboards, the first contact's marking is indicated as reference only.

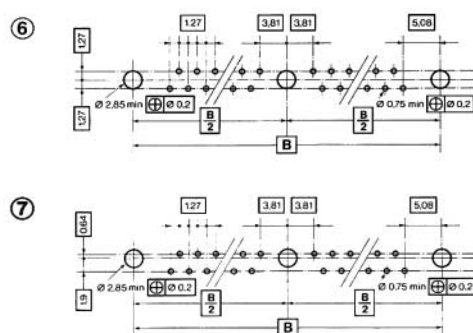

	Motherboard drilling for:			
	Receptacles		Plugs	
	Fittings	Contacts	Fittings	Contacts
Fig. 6	A-AD-AT	Y (pin)	R-RF-RS-T	Y (pin)
Fig. 7	K-L-KD-KT	YD (socket)	E-EF-ES-T	YD (socket)

Dimensions (mm) – Refer to fig. 1 to 7									
Number of contacts	17	29	33	41	53	65	72	84	96
Dimension B	30.48	45.72	50.80	60.96	76.20	91.44	106.68	121.92	137.16
Dimension D	25.90	41.10	46.20	56.40	71.60	86.90	102.10	117.30	132.60

# Panel and printed circuit board drilling for HE 807 / 127 H connectors

## Panel drilling

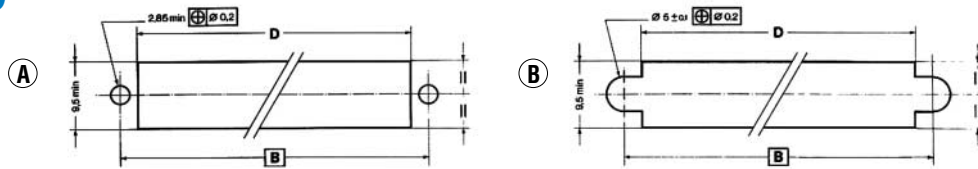

	Receptacles					Plugs				
	Fittings	Pin contacts signal	Pin contacts special	Socket contacts signal	Socket contacts special	Fittings	Pin contacts signal	Pin contacts special	Socket contacts signal	Socket contacts special
<b>Fig. A</b>	K KD KT	W3 ZC-X	Please refer to pages 6 to 8	W3 ZC-X1	Please refer to pages 6 to 8	E EF ES	W3 ZC-X	Please refer to pages 6 to 8	W3 ZC-X1	Please refer to pages 6 to 8
<b>Fig. B</b>	P	W3 ZC-X	Please refer to pages 6 to 8	W3 ZC-X1	Please refer to pages 6 to 8					

## Printed circuit board drilling

**Note:** (referring to the following page)

The boards are illustrated from the connector side

The figures show the drilling of PC boards with connectors equipped with central guides (72, 84 and 96 contacts).

For smaller connectors (17, 29, 33, 41, 53 and 65 contacts), ignore the central drilling. All contacts outputs are equidistant.

The illustrated drilling corresponds to connectors fitted with 3 coaxial or power contacts at one extremity and signal contacts at the other one.

For daughterboards, the first contact's marking is indicated as reference only.

	Daughterboard drilling for:					
	Receptacles			Plugs		
	Fittings	Contacts signal	Contacts coaxial	Fittings	Contacts signal	Contacts coaxial
<b>Fig. 1</b> on page 11	KET	YC	F032/M032	A-D AS-PA	YC	F032/M032
<b>Fig. 2</b> on page 11	KE	YC	F032/M032			
<b>Fig. 3</b> on page 11	IE	YC	F032/M032			
	Fittings	Contacts signal	Contacts power	Fittings	Contacts signal	Contacts power
<b>Fig. 5</b> on page 11	KE	YC	FH3/MH3 F132/M132	A-D AS-PA	YC	FH3/MH3 F132/M132
<b>Fig. 6</b> on page 11	IE	YC	FH3/MH3 F132/M132			
<b>Fig. 7</b> on page 11	IE	YC	FH3/MH3 F132/M132			

	Motherboard drilling for:					
	Receptacles			Plugs		
	Fittings	Contacts signal	Contacts coaxial	Fittings	Contacts signal	Contacts coaxial
<b>Fig. 4</b> on page 11	K KD KT	Y	F041/M041	A-D AS-PA	YC	F041/M041
	Fittings	Contacts signal	Contacts power	Fittings	Contacts signal	Contacts power
<b>Fig. 8</b> on page 11	K KD KT	Y	FH2/MH2 F141/M141	A-D AS-PA	YC	FH2/MH2 F141/M141

Dimensions (mm) – Refer to fig. A and B and to fig. 1 to 8 on page 11								
<b>Number of contacts</b>	5 + 3	17 + 3 5 + 6 0 + 7 0 + 8	29 + 3 17 + 6	41 + 3 29 + 6	53 + 3 41 + 6	60 + 3 48 + 6	72 + 3 60 + 6	84 + 3 72 + 6 56 + 10
<b>Dimension B</b>	17	29	41	53	65	72	84	96
<b>Dimension D</b>	25.90	41.10	56.40	71.60	86.90	102.10	117.30	132.60

# Printed circuit board drilling for HE 807 / 127 H connectors

## Coaxial contacts

## Power contacts

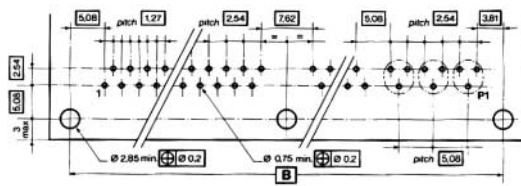

① Daughter board

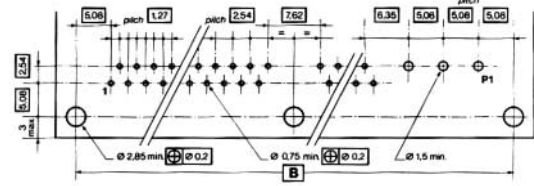

⑤ Daughter board

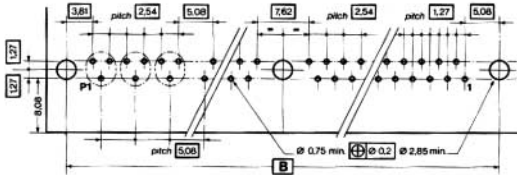

② Daughter board

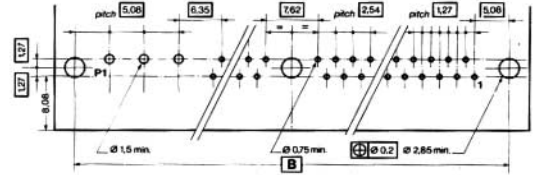

⑥ Daughter board

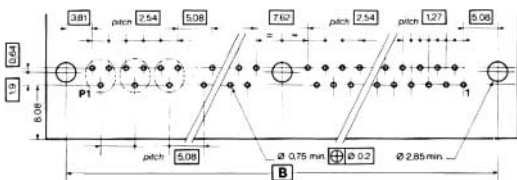

③ Daughter board

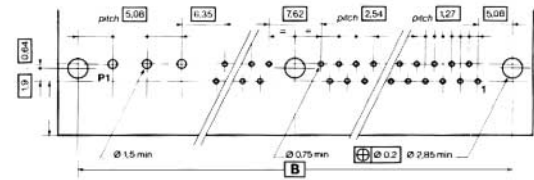

⑦ Daughter board

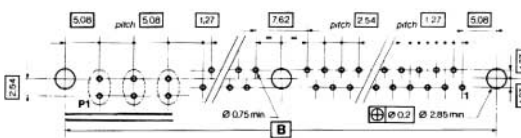

④ Mother board

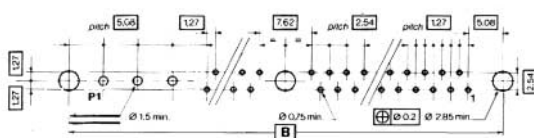

⑧ Mother board

## PCB drilling for 0 + 7 and 0 + 8 insert arrangements

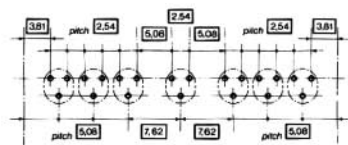

F032/M032 contacts

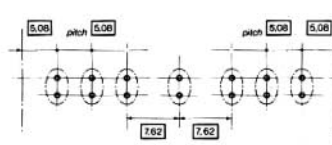

F041/M041 contacts

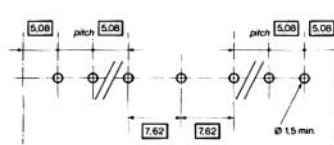

FH2/MH2 contacts  
FH3/MH3 contacts  
F132/M132 contacts  
F141/M141 contacts

For the 0 + 8 insert arrangement, the PCB drilling is the same one as the drilling for the 3 first contacts of the 0 + 7 insert arrangement.

## Hoods with locking rods for HE 804 plugs

Hoods are available for series HE 804 plugs. They are suitable for use with strand and ribbon cables, as well as flex circuits. They are suited to plugs supplied without fittings. The fittings, derived from the standard ones, are delivered with hoods and enable polarisation.

- These hoods are used with HE 804 plugs: - without fittings  
 - fitted with 29, 41 or 65 pin or socket contacts  
 - equipped with U, Z, ZC or X contacts

A hood is composed of the following parts (see fig. 1):

- 2 thermoplastic flanges (a)
- 2 locking rods (b)
- 1 inner cable clamp (c) for strand or flat cable depending of the type of hood
- 2 fittings (d) to ensure the guiding and the polarisation

The working temperature is - 40°C to + 125°C.

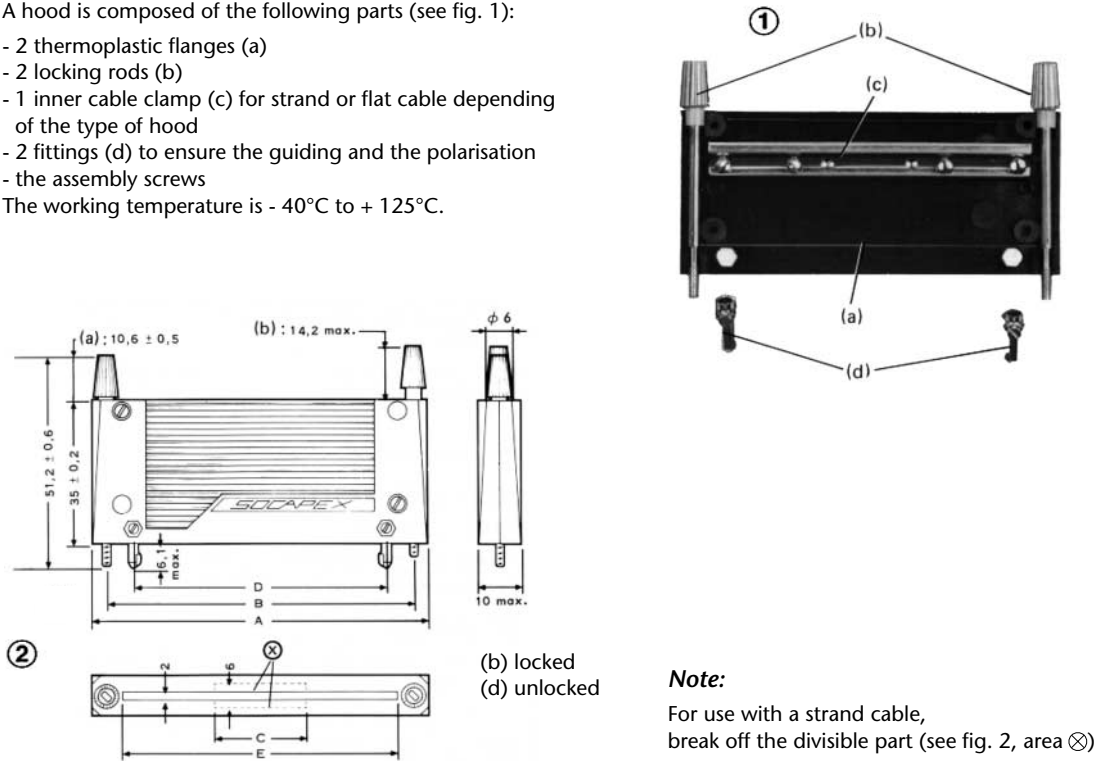

**Note:**  
 For use with a strand cable,  
 break off the divisible part (see fig. 2, area ⊗)

Number of contacts	Dimensions (mm) – see fig. 2				
	A ± 0.3	B	C	D	E
29	65.30	59.32	18.00	47.72	45.80
41	80.50	74.56	22.00	60.96	61.00
65	111.00	105.04	48.00	91.44	91.50

## How to order

<b>Series</b>	<b>127</b>	<b>29</b>	<b>TF</b>	<b>1</b>
<b>Number of contacts</b> 29, 41, 65				
<b>Type of hood</b> TF: hood for female plug TM: hood for male plug				
<b>Type of cable clamp</b> 1: for flat cable or flex circuit 2: for strand cable				

Plugs equipped with hoods mate with receptacles equipped with screwlock sockets (refer to page 13).

## Locking systems for HE 804 plugs

These locking systems are used with HE 804 plugs: - without fittings  
- fitted with 17, 29, 33, 41, 53 or 65 pin or socket contacts  
- equipped with U, Z, ZC or X contacts

A set of locking systems is composed of the following parts (see fig. 1):

- 2 thermoplastic extremity blocks (a) equipped with 2 captive locking rods (b)
  - 2 fittings (d) to ensure the guiding and the polarisation
- The working temperature is - 40°C to + 125°C.

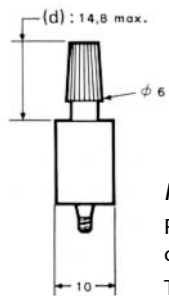
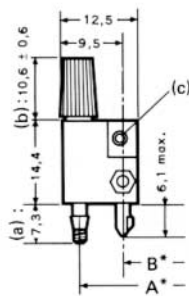
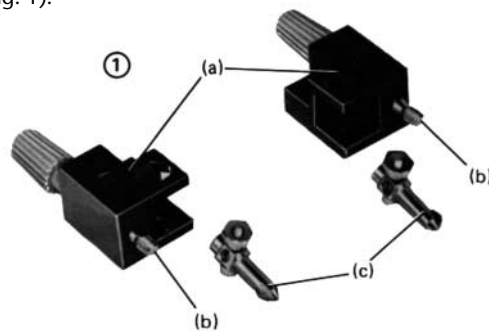

(b) locked  
(d) unlocked

### Note:

For use with ribbon cable or flex circuit, 2 epoxy glass strain relief stripes can be supplied.

They are fastened to point (c) with PARKER CMB n°2 screws (4.8 mm long).

Dimensions (mm) – See fig. 2						
Number of contacts	17	29	33	41	53	65
Dimension A*	44.08	59.32	64.40	74.56	89.80	105.04
Dimension B*	30.48	45.72	50.80	60.96	76.20	91.44

\* A: dimension between the locking rods

B: dimension between the fittings

## How to order

1 set of locking systems for male plug: **12 522**

1 set of locking systems for female plug: **21 351**

Plugs equipped with locking systems mate with receptacles equipped with screwlock sockets.

## Screwlock sockets for HE 804 receptacles

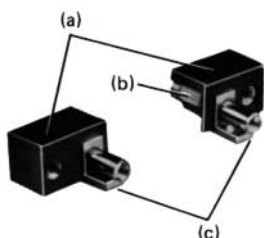
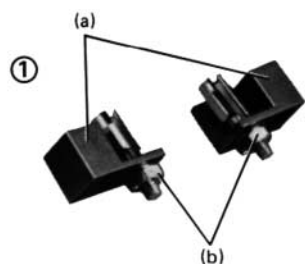

These screwlock sockets allow the mating of HE 804 receptacles with plugs equipped with hoods (refer to page 12) or locking systems (see above).

They are available in 2 versions:

- for perpendicular mounting to a chassis or a motherboard
- with brackets, for receptacles fitted with right angled contacts, mounted on the edge of a daughter board

These screwlock sockets are used with HE 804 receptacles:

- without fittings
- fitted with 17, 29, 33, 41, 53 or 65 pin or socket contacts
- equipped with Z, ZC, YD, Y, W3 or X contacts for sockets without brackets and YC contacts for sockets with brackets

A set of screwlock sockets is composed of the following parts (see fig. 1):

- 2 thermoplastic blocks (a) to be mounted at the extremities of the receptacle. The inner metal tapped parts allow the locking of the plug equipped with a hood or a locking system
- 2 fittings (b) with or without brackets (c) to mount the receptacle on the panel. They mate with the fitting of the plug

The working temperature is - 40°C to + 125°C.

## How to order

1 set of screwlock sockets **without brackets** for male or female receptacle: **21 347**

1 set of screwlock sockets **with brackets** for male or female receptacle: **21 349**

## Dimensions

Fig. 1: sockets without brackets

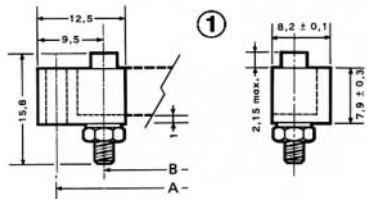
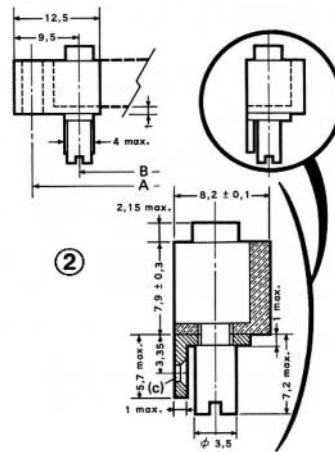

Fig. 2: sockets with brackets (c) hole Ø 1.6 with 90° milling



## Panel drilling

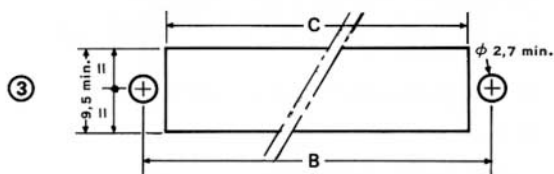

Fig. 3: for receptacles and screwlock sockets without brackets  
max. panel thickness: 3.2 mm

## Printed circuit board drilling

### Motherboards with receptacles and screwlock sockets without brackets

Fig. 4: for male receptacles with Y contacts max.  
panel thickness: 3.2 mm

Fig. 5: for female receptacles with YD contacts max.  
panel thickness: 2.4 mm

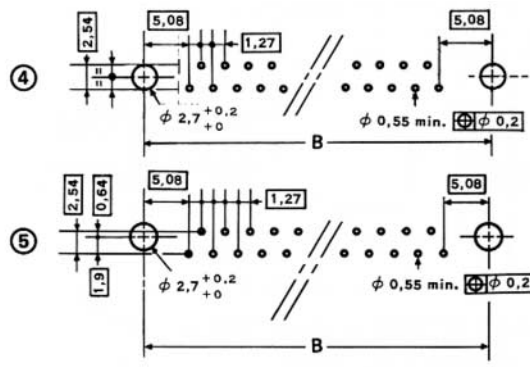

### Daughterboards with receptacles and screwlock sockets with brackets

Fig. 6: for male or female receptacles with YC contacts

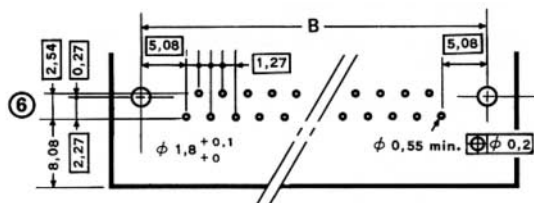

**Note:**

The board is illustrated from the connector side

Dimensions (mm)						
Number of contacts	17	29	33	41	53	65
Dimension A*	44.08	59.32	64.40	74.56	89.80	105.04
Dimension B*	30.48	45.72	50.80	60.96	76.20	91.44
Dimension C*	25.90	41.10	46.20	56.40	71.60	86.90

\* A: dimension between the locking rods

B: dimension between the fittings

## HE 801 – HE 804 3-row female plugs

<b>Series (3 rows)</b>	<b>127</b>	<b>T</b>	<b>144</b>	<b>A</b>	<b>F</b>	<b>-</b>	<b>1</b>	<b>YC</b>	<b>N</b>	<b>-</b>
<b>Number of contacts</b> (refer to p. 2)										
<b>80, 144</b>										
<b>Fittings</b> (refer to p. 4 - 5)										
<b>A, D, AS, PA, KE, KED:</b> for plugs with 80 contacts										
<b>A, AS, D, PA, E:</b> for plugs with 144 contacts										
<b>XL:</b> without fitting (please order fittings separately - refer to p. 19)										
<b>Contacts</b>										
<b>F:</b> socket contacts										
<b>Fittings material</b>										
<b>Blank:</b> nickel plated brass										
<b>1:</b> stainless steel										
<b>Professional and military class</b>										
(1µm gold over nickel on contact area)										
<b>1:</b> tinned plating on YC and Z terminations										
<b>Contact type</b>										
<b>YC, Z, T</b>										
<b>Model</b>										
<b>N:</b> HE 801										
<b>Blank:</b> HE 804										
<b>Cavities marking</b>										
<b>Blank:</b> normal (plug marking)										
<b>B:</b> reversed marking (receptacle marking)										

**Underlined elements:** recommended versions

## HE 801 – HE 804 3-row male receptacles

<b>Series (3 rows)</b>	<b>127</b>	<b>T</b>	<b>144</b>	<b>A</b>	<b>M</b>	<b>-</b>	<b>1</b>	<b>W3</b>	<b>R</b>	<b>-</b>
<b>Number of contacts</b> (refer to p. 2)										
<b>80, 144</b>										
<b>Fittings</b> (refer to p. 4 - 5)										
<b>A, B, D, AD, AT</b>										
<b>X:</b> without fitting (please order fittings separately - refer to p.19)										
<b>Contacts</b>										
<b>M:</b> pin contacts										
<b>Fittings material</b>										
<b>Blank:</b> nickel plated brass										
<b>1:</b> stainless steel										
<b>Professional and military class</b>										
(1 µm gold over nickel on contact area)										
<b>1:</b> tinned plating on Y, YC and ZC terminations gold plating on W3 and X terminations										
<b>6:</b> tinned plating on W3 terminations										
<b>Contact type</b>										
<b>Y, W3, ZC</b>										
<b>Model</b>										
<b>R:</b> HE 801										
<b>Blank:</b> HE 804										
<b>Cavities marking</b>										
<b>Blank:</b> normal (receptacle marking)										
<b>B:</b> reversed marking (plug marking)										

**Underlined elements:** recommended versions

## HE 801 – HE 804 2-row female plugs

<b>Series (2 rows)</b>	<b>127</b>	<b>17</b>	<b>A</b>	<b>F</b>	<b>-</b>	<b>1</b>	<b>YC</b>	<b>N</b>	<b>-</b>
<b>Number of contacts</b> (refer to p. 2)	<b><u>17,29,33,41,53,65,72,84,96</u></b>								
<b>Fittings</b> (refer to p. 4 - 5)	<b>A, PA, AS, D, N, H</b> (for HE 804 only), <b>E, NF, NS, EF, ES, ET, V</b>								
	<b>XL</b> : without fitting (please order fittings separately - refer to p. 19)								
<b>Contacts</b>	<b>F</b> : socket contacts								
<b>Fittings material</b>	<b>Blank</b> : nickel plated brass <b>1</b> : stainless steel								
<b>Professional and military class</b>	(1 µm gold over nickel on contact area) <b>1</b> : tinned plating on YC, Y, Z, T, U and YL terminations gold plating on W3 and X1 terminations <b>6</b> : tinned plating on W3 terminations								
<b>Contact type</b>	<b>YC, U, T</b> : for free plugs <b>W3, Z, YD, Y, X1</b> : for fixed plugs								
<b>Model</b>	<b>N</b> : HE 801 <b>Blank</b> : HE 804								
<b>Cavities marking</b>	<b>Blank</b> : normal (plug marking) <b>B</b> : reversed marking (receptacle marking)								

**Underlined elements**: recommended versions

## HE 801 – HE 804 2-row male receptacles

<b>Series (2 rows)</b>	<b>127</b>	<b>96</b>	<b>A</b>	<b>M</b>	<b>-</b>	<b>1</b>	<b>ZC</b>	<b>R</b>	<b>-</b>
<b>Number of contacts</b> (refer to p. 2)	<b><u>17,29,33,41,53,65,72,84,96</u></b>								
<b>Fittings</b> (refer to p. 4 - 5)	<b>A, B, AE, D, DC, AD AED, AT, AET</b>								
	<b>X</b> : without fitting (please order fittings separately - refer to page 19)								
<b>Contacts</b>	<b>M</b> : pin contacts								
<b>Fittings material</b>	<b>Blank</b> : nickel plated brass <b>1</b> : stainless steel								
<b>Professional and military class</b>	(1 µm gold over nickel on contact area) <b>1</b> : tinned plating on Y, YC, ZC, and YL terminations gold plating on W3 and X terminations <b>6</b> : tinned plating on W3 terminations								
<b>Contact type</b>	<b>YC</b> : for free receptacles <b>W3, ZC, Y, X</b> : for fixed receptacles								
<b>Model</b>	<b>R</b> : HE 801 <b>Blank</b> : HE 804								
<b>Cavities marking</b>	<b>Blank</b> : normal (receptacle marking) <b>B</b> : reversed marking (plug marking)								

**Underlined elements**: recommended versions



**HE 801 – HE 804 2-row male plugs**

<b>Series (2 rows)</b>	<b>127</b>	<b>96</b>	<b>J</b>	<b>M</b>	<b>-</b>	<b>1</b>	<b>YC</b>	<b>R</b>	<b>-</b>
<b>Number of contacts</b> (refer to p. 2)	<b><u>17,29,33,41,53,65,72,84,96</u></b>								
<b>Fittings</b> (refer to p. 4 - 5)	<b><u>J, PC, JS, S, N, R, NF, NS, RF, RS, RT, V</u></b>								
	<b><u>XL</u></b> : without fitting (please order fittings separately - refer to p. 19)								
<b>Contacts</b>	<b>M</b> : pin contacts								
<b>Fittings material</b>	<b>Blank</b> : nickel plated brass <b>1</b> : stainless steel								
<b>Professional and military class</b>	(1 µm gold over nickel on contact area) <b>1</b> : tinned plating on YC, Y, ZC, U and YL terminations gold plating on W3 and X terminations <b>6</b> : tinned plating on W3 terminations								
<b>Contact type</b>	<b>YC, U</b> : for free plugs <b>W3, ZC, Y, X</b> : for fixed plugs								
<b>Model</b>	<b>R</b> : HE 801 <b>Blank</b> : HE 804								
<b>Cavities marking</b>	<b>Blank</b> : normal (plug marking) <b>B</b> : reversed marking (receptacle marking)								

**Underlined elements**: recommended versions**HE 801 – HE 804 2-row female receptacles**

<b>Series (2 rows)</b>	<b>127</b>	<b>29</b>	<b>K</b>	<b>F</b>	<b>-</b>	<b>1</b>	<b>Y</b>	<b>N</b>	<b>-</b>
<b>Number of contacts</b> (refer to p. 2)	<b><u>17,29,33,41,53,65,72,84,96</u></b>								
<b>Fittings</b> (refer to p. 4 - 5)	<b><u>K, P, KE, S, SC, KD, KED, KT, KET</u></b>								
	<b><u>X</u></b> : without-fitting (please order fittings separately - refer to p.19)								
<b>Contacts</b>	<b>F</b> : socket contacts								
<b>Fittings material</b>	<b>Blank</b> : nickel plated brass <b>1</b> : stainless steel								
<b>Professional and military class</b>	(1 µm gold over nickel on contact area) <b>1</b> : tinned plating on YD, Y, Z, YC and YL terminations gold plating on W3 and X1 terminations <b>6</b> : tinned plating on W3 terminations								
<b>Contact type</b>	<b>YC</b> : for free receptacles <b>W3, YD, Y, Z, X1</b> : for fixed receptacles								
<b>Model</b>	<b>N</b> : HE 801 <b>Blank</b> : HE 804								
<b>Cavities marking</b>	<b>Blank</b> : normal (receptacle marking) <b>B</b> : reversed marking (plug marking)								

**Underlined elements**: recommended versions

**HE 807 male or female plugs**

Series	127 H	29	A	F	-	1	YC	N	3A	-
<b>Number of signal contacts</b> (refer to p. 2) <u>5,17,29,41,48,56,60,72</u> : symmetrical arrangements <u>5,17,29,41,53,60,72,84</u> : asymmetrical arrangements										
<b>Fittings</b> (refer to p. 4 - 5) <u>A,AS,D,E,EF,ES,ET,PA,T</u> <u>XL</u> : without fitting (please order fittings separately - refer to p.19)										
<b>Contacts</b> <b>F</b> : socket contacts <b>M</b> : pin contacts										
<b>Fittings material</b> <b>Blank</b> : nickel plated brass <b>1</b> : stainless steel										
<b>Professional and military class</b> (1 µm gold over nickel on contact area) <b>1</b> : tinned plating on YC, Y, Z, ZC and YL terminations gold plating on W3, X and X1 terminations <b>6</b> : tinned plating on W3 terminations										
<b>Contact type</b> <b>YC, W3, X, X1, Z, ZC,Y, T</b>										
<b>HE 807 model</b> <b>N</b> : Socket contacts <b>R</b> : Pin contacts										
<b>Number of cavities for power, coaxial or optical contacts</b> <b>3A</b> : 3 cavities <b>6A</b> : 6 cavities <b>10A</b> : 10 cavities (please order power, coaxial and optical contacts separately - refer to pages 6 to 8)										
<b>Contact marking</b> <b>Blank</b> : normal (plug marking) <b>B</b> : reversed marking (receptacle marking) Note: The asymmetrical arrangements ever have reversed marking on male plugs										
<b>Underlined elements</b> : recommended versions										

## HE 807 male or female receptacles

<b>Series</b>	<b>127 H 29 A F - 1 YC N 3A -</b>
<b>Number of signal contacts</b> (refer to p. 2) <b>5,17,29,41,48,56,60,72:</b> symmetrical arrangements <b>5,17,29,41,53,60,72,84:</b> asymmetrical arrangements	
<b>Fittings</b> (refer to p. 4 - 5) <b>IE,K,KE,KED,KET,KD,KT,P,S</b> <b>X:</b> without fitting (please order fittings separately - refer to p. 19)	
<b>Contacts</b> <b>F:</b> socket contacts <b>M:</b> pin contacts	
<b>Fittings material</b> <b>Blank:</b> nickel plated brass <b>1:</b> stainless steel	
<b>Professional and military class</b> (1 µm gold over nickel on contact area) <b>1:</b> tinned plating on YC, Y, Z, ZC and YL terminations gold plating on W3, X and X1 terminations <b>6:</b> tinned plating on W3 terminations	
<b>Contact type</b> <b>YC, W3, X, X1, Z, ZC, Y</b>	
<b>HE 807 model</b> <b>N:</b> Socket contacts <b>R:</b> Pin contacts	
<b>Number of cavities for power, coaxial or optical contacts</b> <b>3A:</b> 3 cavities <b>6A:</b> 6 cavities <b>10A:</b> 10 cavities (please order power, coaxial and optical contacts separately - refer to pages 6 to 8)	
<b>Contact marking</b> <b>Blank:</b> normal (plug marking) <b>B:</b> reversed marking (receptacle marking) Note: The asymmetrical arrangements ever have reversed marking on female receptacles	

**Underlined elements:** recommended versions

### HE 807 plugs without signal contacts

Insert with 7 cavities for specific contacts without fittings	<b>127 H 0 XL 0 1 00 H 7A</b>
Insert with 8 cavities for specific contacts without fittings (recommended for fiber optical applications)	<b>127 H 0 XL 0 1 00 H 8A</b>

### HE 807 receptacles without signal contacts

Insert with 7 cavities for specific contacts without fittings	<b>127 H 0 X 0 1 00 H 7A</b>
Insert with 8 cavities for specific contacts without fittings (recommended for fiber optical applications)	<b>127 H 0 X 0 1 00 H 8A</b>

### Fittings (for connectors ordered without fitting: XL or X)

<b>Fitting</b>	<b>HE 8 C</b>	<b>101</b>
<b>Fitting type</b> <b>1XX:</b> male for plug - nickel plated brass <b>2XX:</b> female for receptacle - nickel plated brass <b>3XX:</b> male for plug - stainless steel <b>4XX:</b> female for receptacle - stainless steel For XX, please refer to charts on pages 4 and 5 (HE8C P/N)		



# Cross references chart HE 804 / 127

Connectors with 2 fitting locations (17, 29, 41, 53 and 65 contacts)							
Connectors with fittings		Connectors without fitting + 2 separate fittings		Connectors with fittings		Connectors without fitting + 2 separate fittings	
HE 804 references	Amphenol P/N	Amphenol P/N	and brass or stainless steel fittings	HE 804 references	Amphenol P/N	Amphenol P/N	and brass or stainless steel fittings
HE 804 ES 17 S1 1 A 000 2 HE 804 FS 17 S1 1 A 110 2 HE 804 FS 17 S1 1 A 112 2 HE 804 FS 17 S1 1 A 125 2 HE 804 ES 17 S1 1 A 201 2	127 17 X F 1X1 127 17 E F 1X1 127 17 EF F 1X1 127 17 ES F 1X1 127 17 K F 1X1	127 17 XL F 1X1 127 17 XL F 1X1 127 17 XL F 1X1 127 17 X F 1X1	and HE 8 C 110 or HE 8 C 310 and HE 8 C 112 or HE 8 C 312 and HE 8 C 125 or HE 8 C 325 and HE 8 C 201 or HE 8 C 401	HE 804 FP 17 Y 1 A 000 3 HE 804 FP 17 Y 1 A 101 3 HE 804 FP 17 Y 1 A 102 3 HE 804 FP 17 Y 1 A 103 3 HE 804 EP 17 Y 1 A 209 3	127 17 XL M 1YC 127 17 J M 1YC 127 17 PC M 1YC 127 17 S M 1YC 127 17 AE M 1YC	127 17 XL M 1YC 127 17 XL M 1YC 127 17 XL M 1YC 127 17 X M 1YC	and HE 8 C 101 or HE 8 C 301 and HE 8 C 102 or HE 8 C 302 and HE 8 C 103 or HE 8 C 303 and HE 8 C 209 or HE 8 C 409
HE 804 EN 17 S2 1 A 000 2 HE 804 FN 17 S2 1 A 110 2 HE 804 FN 17 S2 1 A 112 2 HE 804 FN 17 S2 1 A 125 2 HE 804 EN 17 S2 1 A 201 2 HE 804 EN 17 S2 1 A 203 2 HE 804 EN 17 S2 1 A 220 2	127 17 X M 1X 127 17 R M 1X 127 17 RF M 1X 127 17 RS M 1X 127 17 A M 1X 127 17 B M 1X 127 17 D M 1X	127 17 XL M 1X 127 17 XL M 1X 127 17 XL M 1X 127 17 X M 1X 127 17 X M 1X 127 17 X M 1X 127 17 X M 1X	and HE 8 C 110 or HE 8 C 310 and HE 8 C 112 or HE 8 C 312 and HE 8 C 125 or HE 8 C 325 and HE 8 C 201 or HE 8 C 401 and HE 8 C 203 or HE 8 C 403 and HE 8 C 220 or HE 8 C 420	HE 804 ES 17 Y 0 A 000 3 HE 804 FS 17 Y 0 A 110 3 HE 804 FS 17 Y 0 A 112 3 HE 804 FS 17 Y 0 A 125 3 HE 804 ES 17 Y 0 A 201 3	127 17 X F 1YD 127 17 E F 1YD 127 17 EF F 1YD 127 17 ES F 1YD 127 17 K F 1YD	127 17 XL F 1YD 127 17 XL F 1YD 127 17 XL F 1YD 127 17 X F 1YD	and HE 8 C 110 or HE 8 C 310 and HE 8 C 112 or HE 8 C 312 and HE 8 C 125 or HE 8 C 325 and HE 8 C 201 or HE 8 C 401
HE 804 ES 17 W 0 A 000 2 HE 804 FS 17 W 0 A 110 2 HE 804 FS 17 W 0 A 112 2 HE 804 FS 17 W 0 A 125 2 HE 804 ES 17 W 0 A 201 2	127 17 X F 1W3 127 17 E F 1W3 127 17 EF F 1W3 127 17 ES F 1W3 127 17 K F 1W3	127 17 XL F 1W3 127 17 XL F 1W3 127 17 XL F 1W3 127 17 X F 1W3	and HE 8 C 110 or HE 8 C 310 and HE 8 C 112 or HE 8 C 312 and HE 8 C 125 or HE 8 C 325 and HE 8 C 201 or HE 8 C 401	HE 804 EN 17 Z 1 A 000 3 HE 804 FN 17 Z 1 A 110 3 HE 804 FN 17 Z 1 A 112 3 HE 804 FN 17 Z 1 A 125 3 HE 804 EN 17 Z 1 A 201 3 HE 804 EN 17 Z 1 A 203 3 HE 804 EN 17 Z 1 A 220 3	127 17 X M 1ZC 127 17 R M 1ZC 127 17 RF M 1ZC 127 17 RS M 1ZC 127 17 A M 1ZC 127 17 B M 1ZC 127 17 D M 1ZC	127 17 XL M 1ZC 127 17 XL M 1ZC 127 17 XL M 1ZC 127 17 X M 1ZC 127 17 X M 1ZC 127 17 X M 1ZC 127 17 X M 1ZC	and HE 8 C 110 or HE 8 C 310 and HE 8 C 112 or HE 8 C 312 and HE 8 C 125 or HE 8 C 325 and HE 8 C 201 or HE 8 C 401 and HE 8 C 203 or HE 8 C 403 and HE 8 C 220 or HE 8 C 420
HE 804 EN 17 Y 0 A 000 3 HE 804 FN 17 Y 0 A 110 3 HE 804 FN 17 Y 0 A 112 3 HE 804 FN 17 Y 0 A 125 3 HE 804 EN 17 Y 0 A 201 3 HE 804 EN 17 Y 0 A 203 3	127 17 X M 1Y 127 17 R M 1Y 127 17 RF M 1Y 127 17 RS M 1Y 127 17 A M 1Y 127 17 B M 1Y	127 17 XL M 1Y 127 17 XL M 1Y 127 17 XL M 1Y 127 17 X M 1Y 127 17 X M 1Y 127 17 X M 1Y	and HE 8 C 110 or HE 8 C 310 and HE 8 C 112 or HE 8 C 312 and HE 8 C 125 or HE 8 C 325 and HE 8 C 201 or HE 8 C 401 and HE 8 C 203 or HE 8 C 403	HE 804 FC 17 U 1 A 000 3 HE 804 FC 17 U 1 A 106 3 HE 804 FC 17 U 1 A 108 3	127 17 XL F 1U 127 17 N F 1U 127 17 NF F 1U	127 17 XL F 1U 127 17 XL F 1U 127 17 XL F 1U	and HE 8 C 106 or HE 8 C 306 and HE 8 C 108 or HE 8 C 308 and HE 8 C 107 or HE 8 C 307 and HE 8 C 109 or HE 8 C 309 and HE 8 C 105 or HE 8 C 305
HE 804 FB 17 Y 1 A 000 3 HE 804 FB 17 Y 1 A 101 3 HE 804 FB 17 Y 1 A 102 3 HE 804 FB 17 Y 1 A 103 3 HE 804 EB 17 Y 1 A 209 3	127 17 XL F 1YC 127 17 A F 1YC 127 17 PA F 1YC 127 17 D F 1YC 127 17 KE F 1YC	127 17 XL F 1YC 127 17 XL F 1YC 127 17 XL F 1YC 127 17 X F 1YC	and HE 8 C 101 or HE 8 C 301 and HE 8 C 102 or HE 8 C 302 and HE 8 C 103 or HE 8 C 303 and HE 8 C 209 or HE 8 C 409	HE 804 FP 17 U 0 A 000 3 HE 804 FP 17 U 0 A 106 3 HE 804 FP 17 U 0 A 108 3 HE 804 FP 17 U 0 A 104 3	127 17 XL M 1U 127 17 N M 1U 127 17 NF M 1U 127 17 V M 1U	127 17 XL M 1U 127 17 XL M 1U 127 17 XL M 1U 127 17 XL M 1U	and HE 8 C 106 or HE 8 C 306 and HE 8 C 108 or HE 8 C 308 and HE 8 C 104 or HE 8 C 304

Connectors with 3 fitting locations (72, 84 and 96 contacts)							
HE 804 references	Amphenol P/N (no fitting)	Amphenol P/N (no fitting)	and brass or stainless steel 2 extremity + 1 central fittings HE 8 C...	HE 804 references	Amphenol P/N (no fitting)	Amphenol P/N (no fitting)	and brass or stainless steel 2 extremity + 1 central fittings HE 8 C...
HE 804 ES 72 S1 1 A 000 2 HE 804 FS 72 S1 1 A 110 2 HE 804 FS 72 S1 1 A 112 2 HE 804 FS 72 S1 1 A 125 2 HE 804 ES 72 S1 1 A 201 2	127 72 X F 1X1 127 72 E F 1X1 127 72 EF F 1X1 127 72 ES F 1X1 127 72 K F 1X1	127 72 XL F 1X1 127 72 XL F 1X1 127 72 XL F 1X1 127 72 X F 1X1	and ...110 +...113 or...310 +...313 and ...112 +...113 or...312 +...313 and ...125 +...113 or...325 +...313 and ...201 +...202 or...401 +...402	HE 804 FS 72 Z 1 B 112 3 HE 804 FS 72 Z 1 B 125 3 HE 804 FS 72 Z 1 B 201 3	127 72 EF F 1Z 127 72 ES F 1Z 127 72 K F 1Z	127 72 XL F 1Z 127 72 XL F 1Z 127 72 X F 1Z	and ...112 +...113 or...312 +...313 and ...125 +...113 or...325 +...313 and ...201 +...202 or...401 +...402
HE 804 EN 72 S2 1 A 000 2 HE 804 FN 72 S2 1 A 110 2 HE 804 FN 72 S2 1 A 112 2 HE 804 FN 72 S2 1 A 125 2 HE 804 EN 72 S2 1 A 201 2 HE 804 EN 72 S2 1 A 203 2 HE 804 EN 72 S2 1 A 220 2	127 72 X M 1X 127 72 R M 1X 127 72 RF M 1X 127 72 RS M 1X 127 72 A M 1X 127 72 B M 1X 127 72 D M 1X	127 72 XL M 1X 127 72 XL M 1X 127 72 XL M 1X 127 72 X M 1X 127 72 X M 1X 127 72 X M 1X 127 72 X M 1X	and ...110 +...113 or...310 +...313 and ...112 +...113 or...312 +...313 and ...125 +...113 or...325 +...313 and ...201 +...202 or...401 +...402 and ...203 +...202 or...403 +...402 and ...220 +...202 or...420 +...402	HE 804 ES 72 W 0 B 000 2 HE 804 FS 72 W 0 B 110 2 HE 804 FS 72 W 0 B 112 2 HE 804 FS 72 W 0 B 125 2 HE 804 ES 72 W 0 B 201 2	127 72 X F 1W3 127 72 E F 1W3 127 72 EF F 1W3 127 72 ES F 1W3 127 72 K F 1W3	127 72 XL F 1W3 127 72 XL F 1W3 127 72 XL F 1W3 127 72 X F 1W3	and ...110 +...113 or...310 +...313 and ...112 +...113 or...312 +...313 and ...125 +...113 or...325 +...313 and ...201 +...202 or...401 +...402 and ...203 +...202 or...403 +...402 and ...220 +...202 or...420 +...402
HE 804 EN 72 W 0 B 000 2 HE 804 FN 72 W 0 B 110 2 HE 804 FN 72 W 0 B 112 2 HE 804 FN 72 W 0 B 125 2 HE 804 EN 72 W 0 B 201 2 HE 804 EN 72 W 0 B 203 2 HE 804 EN 72 W 0 B 220 2	127 72 X M 1W3 127 72 R M 1W3 127 72 RF M 1W3 127 72 RS M 1W3 127 72 A M 1W3 127 72 B M 1W3 127 72 D M 1W3	127 72 XL M 1W3 127 72 XL M 1W3 127 72 XL M 1W3 127 72 X M 1W3 127 72 X M 1W3 127 72 X M 1W3 127 72 X M 1W3	and ...110 +...113 or...310 +...313 and ...112 +...113 or...312 +...313 and ...125 +...113 or...325 +...313 and ...201 +...202 or...401 +...402 and ...203 +...202 or...403 +...402 and ...220 +...202 or...420 +...402	HE 804 ES 72 W 0 A 000 2 HE 804 FS 72 W 0 A 112 2 HE 804 FS 72 W 0 A 125 2 HE 804 ES 72 W 0 A 201 2	127 72 X FA 1W3 127 72 EF FA 1W3 127 72 S FA 1W3 127 72 K FA 1W3	127 72 XL FA 1W3 127 72 XL FA 1W3 127 72 X FA 1W3	and ...113 +...113 or...312 +...313 and ...113 +...113 or...325 +...313 and ...202 +...202 or...401 +...402
HE 804 EN 72 Y 0 A 000 3 HE 804 FN 72 Y 0 A 110 3 HE 804 FN 72 Y 0 A 112 3 HE 804 FN 72 Y 0 A 125 3 HE 804 EN 72 Y 0 A 201 3 HE 804 EN 72 Y 0 A 203 3	127 72 X M 1Y 127 72 R M 1Y 127 72 RF M 1Y 127 72 RS M 1Y 127 72 A M 1Y 127 72 B M 1Y	127 72 XL M 1Y 127 72 XL M 1Y 127 72 XL M 1Y 127 72 X M 1Y 127 72 X M 1Y 127 72 X M 1Y	and ...110 +...113 or...310 +...313 and ...112 +...113 or...312 +...313 and ...125 +...113 or...325 +...313 and ...201 +...202 or...401 +...402 and ...203 +...202 or...403 +...402	HE 804 EN 72 W 0 A 000 2 HE 804 FN 72 W 0 A 110 2 HE 804 FN 72 W 0 A 111 2 HE 804 FN 72 W 0 A 112 2 HE 804 FN 72 W 0 A 125 2 HE 804 EN 72 W 0 A 201 2 HE 804 EN 72 W 0 A 220 2	127 72 X MA 1W3 127 72 R MA 1W3 127 72 T MA 1W3 127 72 RF MA 1W3 127 72 RS MA 1W3 127 72 A MA 1W3 127 72 D MA 1W3	127 72 XL MA 1W3 127 72 XL MA 1W3 127 72 XL MA 1W3 127 72 X MA 1W3 127 72 X MA 1W3 127 72 X MA 1W3 127 72 X MA 1W3	and ...113 +...113 or...310 +...313 and ...113 +...113 or...311 +...313 and ...113 +...113 or...312 +...313 and ...113 +...113 or...325 +...313 and ...202 +...202 or...401 +...402 and ...202 +...202 or...420 +...402
HE 804 FB 72 Y 1 A 000 3 HE 804 FB 72 Y 1 A 101 3 HE 804 FB 72 Y 1 A 102 3 HE 804 FB 72 Y 1 A 103 3 HE 804 EB 72 Y 1 A 209 3	127 72 XL F 1YC 127 72 A F 1YC 127 72 PA F 1YC 127 72 D F 1YC 127 72 KE F 1YC	127 72 XL F 1YC 127 72 XL F 1YC 127 72 XL F 1YC 127 72 X F 1YC	and ...101 +...102 or...301 +...302 and ...102 +...102 or...303 +...302 and ...103 +...102 or...303 +...303 and ...209 +...209 or...409 +...409	HE 804 ES 72 Z 1 A 000 3 HE 804 FS 72 Z 1 A 110 3 HE 804 FS 72 Z 1 A 112 3 HE 804 FS 72 Z 1 A 125 3 HE 804 ES 72 Z 1 A 201 3	127 72 X FA 1Z 127 72 E FA 1Z 127 72 S FA 1Z 127 72 K FA 1Z	127 72 XL FA 1Z 127 72 XL FA 1Z 127 72 X FA 1Z	and ...110 +...113 or...310 +...313 and ...112 +...113 or...312 +...313 and ...125 +...113 or...325 +...313 and ...201 +...202 or...401 +...402
HE 804 FP 72 Y 1 A 000 3 HE 804 FP 72 Y 1 A 101 3 HE 804 FP 72 Y 1 A 102 3 HE 804 FP 72 Y 1 A 103 3 HE 804 EP 72 Y 1 A 209 3	127 72 XL M 1YC 127 72 J M 1YC 127 72 PC M 1YC 127 72 S M 1YC 127 72 AE M 1YC	127 72 XL M 1YC 127 72 XL M 1YC 127 72 XL M 1YC 127 72 X M 1YC	and ...101 +...102 or...301 +...302 and ...102 +...102 or...302 +...302 and ...103 +...102 or...303 +...303 and ...209 +...209 or...409 +...409	HE 804 EN 72 Z 1 A 000 3 HE 804 FN 72 Z 1 A 110 3 HE 804 FN 72 Z 1 A 112 3 HE 804 FN 72 Z 1 A 125 3 HE 804 EN 72 Z 1 A 201 3 HE 804 EN 72 Z 1 A 203 3 HE 804 EN 72 Z 1 A 220 3	127 72 X MA 1ZC 127 72 R MA 1ZC 127 72 RF MA 1ZC 127 72 RS MA 1ZC 127 72 A MA 1ZC 127 72 B MA 1ZC 127 72 D MA 1ZC	127 72 XL MA 1ZC 127 72 XL MA 1ZC 127 72 XL MA 1ZC 127 72 X MA 1ZC 127 72 X MA 1ZC 127 72 X MA 1ZC 127 72 X MA 1ZC	and ...110 +...113 or...310 +...313 and ...112 +...113 or...312 +...313 and ...125 +...113 or...325 +...313 and ...201 +...202 or...401 +...402 and ...203 +...202 or...403 +...402 and ...220 +...202 or...420 +...402
HE 804 ES 72 Z 1 B 000 3 HE 804 FS 72 Z 1 B 110 3	127 72 X F 1Z 127 72 E F 1Z	127 72 XL F 1Z 127 72 XL F 1Z	and ...110 +...113 or...310 +...313 and ...112 +...113 or...312 +...313 and ...125 +...113 or...325 +...313 and ...201 +...202 or...401 +...402	HE 804 FC 72 U 1 A 000 3 HE 804 FC 72 U 1 A 104 3 HE 804 FC 72 U 1 A 106 3 HE 804 FC 72 U 1 A 108 3	127 72 XL F 1U 127 72 V F 1U 127 72 NF F 1U	127 72 XL F 1U 127 72 XL F 1U 127 72 XL F 1U	and ...104 +...104 or...304 +...304 and ...106 +...104 or...306 +...304 and ...108 +...104 or...308 +...304
HE 804 ES 72 Z 1 B 000 3 HE 804 FS 72 Z 1 B 110 3	127 72 X F 1Z 127 72 E F 1Z	127 72 XL F 1Z 127 72 XL F 1Z	and ...110 +...113 or...310 +...313 and ...112 +...113 or...312 +...313 and ...125 +...113 or...325 +...313 and ...201 +...202 or...401 +...402	HE 804 FP 72 U 0 A 000 3 HE 804 FP 72 U 0 A 106 3 HE 804 FP 72 U 0 A 108 3 HE 804 FP 72 U 0 A 104 3	127 72 XL M 1U 127 72 N M 1U 127 72 NF M 1U 127 72 V M 1U	127 72 XL M 1U 127 72 XL M 1U 127 72 XL M 1U 127 72 XL M 1U	and ...106 +...104 or...306 +...304 and ...108 +...104 or...308 +...304 and ...104 +...104 or...304 +...304

Cross references chart HE 807 / 127 H

Connectors with 2 fitting locations						
Connectors with fittings		Connectors without fitting	+	2 separate fittings		
HE 807 references	Amphenol P/N	Amphenol P/N without fitting	and	2 brass fittings	or	2 stainless steel fittings
<b>ASYMETRICAL ARRANGEMENTS</b>						
HE 807 FB 17 Y 1 A 3 000 3	127 H 17 XL F 1 YC N 3A	127 H 17 XL F 1 YC N 3A				
HE 807 FB 17 Y 1 A 3 101 3	127 H 17 A F 1 YC N 3A	127 H 17 XL F 1 YC N 3A	and	HE8C 101	or	HE8C 301
HE 807 FB 17 Y 1 A 3 102 3	127 H 17 PA F 1 YC N 3A	127 H 17 XL F 1 YC N 3A	and	HE8C 102	or	HE8C 302
HE 807 FB 17 Y 1 A 3 103 3	127 H 17 D F 1 YC N 3A	127 H 17 XL F 1 YC N 3A	and	HE8C 103	or	HE8C 303
HE 807 FB 17 Y 1 A 3 206 3	127 H 17 IE F 1 YC N 3AB	127 H 17 XL F 1 YC N 3A	and	HE8C 206	or	HE8C 406
HE 807 FB 17 Y 1 A 3 208 3	127 H 17 KE F 1 YC N 3AB	127 H 17 XL F 1 YC N 3A	and	HE8C 208	or	HE8C 408
HE 807 EP 17 Y 1 A 3 000 3	127 H 17 X M 1 YC R 3A	127 H 17 X M 1 YC R 3A				
HE 807 EP 17 Y 1 A 3 101 3	127 H 17 A M 1 YC R 3AB	127 H 17 X M 1 YC R 3A	and	HE8C 101	or	HE8C 301
HE 807 EP 17 Y 1 A 3 102 3	127 H 17 PA M 1 YC R 3AB	127 H 17 X M 1 YC R 3A	and	HE8C 102	or	HE8C 302
HE 807 EP 17 Y 1 A 3 103 3	127 H 17 D M 1 YC R 3AB	127 H 17 X M 1 YC R 3A	and	HE8C 103	or	HE8C 303
HE 807 EP 17 Y 1 A 3 206 3	127 H 17 IE M 1 YC R 3A	127 H 17 X M 1 YC R 3A	and	HE8C 206	or	HE8C 406
HE 807 EP 17 Y 1 A 3 208 3	127 H 17 KE M 1 YC R 3A	127 H 17 X M 1 YC R 3A	and	HE8C 208	or	HE8C 408
HE 807 FS 17 W 0 A 3 000 2	127 H 17 XL F 1 W3 N 3A	127 H 17 XL F 1 W3 N 3A				
HE 807 FS 17 W 0 A 3 117 2	127 H 17 E F 1 W3 N 3A	127 H 17 XL F 1 W3 N 3A	and	HE8C 117	or	HE8C 317
HE 807 FS 17 W 0 A 3 212 2	127 H 17 K F 1 W3 N 3AB	127 H 17 XL F 1 W3 N 3A	and	HE8C 212	or	HE8C 412
HE 807 FS 17 W 0 A 3 213 2	127 H 17 S F 1 W3 N 3AB	127 H 17 XL F 1 W3 N 3A	and	HE8C 213	or	HE8C 413
HE 807 FS 17 W 0 A 3 226 2	127 H 17 P F 1 W3 N 3AB	127 H 17 XL F 1 W3 N 3A	and	HE8C 226	or	HE8C 426
HE 807 EN 17 W 0 A 3 000 2	127 H 17 X M 1 W3 R 3A	127 H 17 X M 1 W3 R 3A				
HE 807 EN 17 W 0 A 3 212 2	127 H 17 K M 1 W3 R 3A	127 H 17 X M 1 W3 R 3A	and	HE8C 212	or	HE8C 412
HE 807 EN 17 W 0 A 3 213 2	127 H 17 S M 1 W3 R 3A	127 H 17 X M 1 W3 R 3A	and	HE8C 213	or	HE8C 413
HE 807 EN 17 W 0 A 3 117 2	127 H 17 E M 1 W3 R 3AB	127 H 17 X M 1 W3 R 3A	and	HE8C 117	or	HE8C 317
HE 807 EN 17 Y 0 A 3 000 3	127 H 17 X M 1 Y R 3A	127 H 17 X M 1 Y R 3A				
HE 807 EN 17 Y 0 A 3 212 3	127 H 17 K M 1 Y R 3A	127 H 17 X M 1 Y R 3A	and	HE8C 212	or	HE8C 412
HE 807 EN 17 Y 0 A 3 213 3	127 H 17 S M 1 Y R 3A	127 H 17 X M 1 Y R 3A	and	HE8C 213	or	HE8C 413
HE 807 EN 17 Y 0 A 3 117 3	127 H 17 E M 1 Y R 3AB	127 H 17 X M 1 Y R 3A	and	HE8C 117	or	HE8C 317
HE 807 FS 17 Y 0 A 3 000 3	127 H 17 XL F 1 Y N 3A	127 H 17 XL F 1 Y N 3A				
HE 807 FS 17 Y 0 A 3 117 3	127 H 17 E F 1 Y N 3A	127 H 17 XL F 1 Y N 3A	and	HE8C 117	or	HE8C 317
HE 807 FS 17 Y 0 A 3 212 3	127 H 17 K F 1 Y N 3AB	127 H 17 XL F 1 Y N 3A	and	HE8C 212	or	HE8C 412
HE 807 FS 17 Y 0 A 3 213 3	127 H 17 S F 1 Y N 3AB	127 H 17 XL F 1 Y N 3A	and	HE8C 213	or	HE8C 413
HE 807 EN 17 Z 1 A 3 000 3	127 H 17 X M 1 ZC R 3A	127 H 17 X M 1 ZC R 3A				
HE 807 EN 17 Z 1 A 3 212 3	127 H 17 K M 1 ZC R 3A	127 H 17 X M 1 ZC R 3A	and	HE8C 212	or	HE8C 412
HE 807 EN 17 Z 1 A 3 213 3	127 H 17 S M 1 ZC R 3A	127 H 17 X M 1 ZC R 3A	and	HE8C 213	or	HE8C 413
HE 807 EN 17 Z 1 A 3 117 3	127 H 17 E M 1 ZC R 3AB	127 H 17 X M 1 ZC R 3A	and	HE8C 117	or	HE8C 317
HE 807 FS 17 Z 1 A 3 000 3	127 H 17 XL F 1 Z N 3A	127 H 17 XL F 1 Z N 3A				
HE 807 FS 17 Z 1 A 3 117 3	127 H 17 E F 1 Z N 3A	127 H 17 XL F 1 Z N 3A	and	HE8C 117	or	HE8C 417
HE 807 FS 17 Z 1 A 3 212 3	127 H 17 K F 1 Z N 3AB	127 H 17 XL F 1 Z N 3A	and	HE8C 212	or	HE8C 412
HE 807 FS 17 Z 1 A 3 213 3	127 H 17 S F 1 Z N 3AB	127 H 17 XL F 1 Z N 3A	and	HE8C 213	or	HE8C 413
<b>SYMMETRICAL ARRANGEMENTS</b>						
HE 807 FB 17 Y 1 A 6 000 3	127 H 17 XL F 1 YC N 6A	127 H 17 XL F 1 YC N 6A				
HE 807 FB 17 Y 1 A 6 101 3	127 H 17 A F 1 YC N 6A	127 H 17 XL F 1 YC N 6A	and	HE8C 101	or	HE8C 301
HE 807 FB 17 Y 1 A 6 102 3	127 H 17 PA F 1 YC N 6A	127 H 17 XL F 1 YC N 6A	and	HE8C 102	or	HE8C 302
HE 807 FB 17 Y 1 A 6 103 3	127 H 17 D F 1 YC N 6A	127 H 17 XL F 1 YC N 6A	and	HE8C 103	or	HE8C 303
HE 807 EB 17 Y 1 A 6 206 3	127 H 17 IE F 1 YC N 6A	127 H 17 X F 1 YC N 6A	and	HE8C 206	or	HE8C 406
HE 807 EB 17 Y 1 A 6 208 3	127 H 17 KE F 1 YC N 6A	127 H 17 X F 1 YC N 6A	and	HE8C 208	or	HE8C 408
HE 807 EP 17 Y 1 A 6 000 3	127 H 17 X M 1 YC N 6A	127 H 17 X M 1 YC N 6A				
HE 807 FP 17 Y 1 A 6 101 3	127 H 17 A M 1 YC R 6A	127 H 17 XL M 1 YC R 6A	and	HE8C 101	or	HE8C 301
HE 807 FP 17 Y 1 A 6 000 3	127 H 17 XL M 1 YC R 6A	127 H 17 XL M 1 YC R 6A				
HE 807 EP 17 Y 1 A 6 208 3	127 H 17 KE M 1 YC R 6A	127 H 17 X M 1 YC R 6A	and	HE8C 208	or	HE8C 408
HE 807 ES 17 W 0 A 6 000 2	127 H 17 X F 1 W3 N 6A	127 H 17 X F 1 W3 N 6A				
HE 807 FS 17 W 0 A 6 117 2	127 H 17 E F 1 W3 N 6A	127 H 17 XL F 1 W3 N 6A	and	HE8C 117	or	HE8C 317
HE 807 FS 17 W 0 A 6 000 2	127 H 17 XL F 1 W3 N 6A	127 H 17 XL F 1 W3 N 6A				
HE 807 ES 17 W 0 A 6 212 2	127 H 17 K F 1 W3 N 6A	127 H 17 X F 1 W3 N 6A	and	HE8C 212	or	HE8C 412
HE 807 EN 17 W 0 A 6 000 2	127 H 17 X M 1 W3 R 6A	127 H 17 X M 1 W3 R 6A				
HE 807 FN 17 W 0 A 6 117 2	127 H 17 E M 1 W3 R 6A	127 H 17 XL M 1 W3 R 6A	and	HE8C 117	or	HE8C 317
HE 807 FN 17 W 0 A 6 000 2	127 H 17 XL M 1 W3 R 6A	127 H 17 XL M 1 W3 R 6A				
HE 807 EN 17 W 0 A 6 212 2	127 H 17 K M 1 W3 R 6A	127 H 17 X M 1 W3 R 6A	and	HE8C 212	or	HE8C 412
HE 807 ES 17 Y 0 A 6 000 3	127 H 17 X F 1 Y N 6A	127 H 17 X F 1 Y N 6A				
HE 807 FS 17 Y 0 A 6 117 3	127 H 17 E F 1 Y N 6A	127 H 17 XL F 1 Y N 6A	and	HE8C 117	or	HE8C 317
HE 807 FS 17 Y 0 A 6 000 3	127 H 17 XL F 1 Y N 6A	127 H 17 XL F 1 Y N 6A				
HE 807 FS 17 Y 0 A 6 119 3	127 H 17 KE F 1 Y N 6A	127 H 17 XL F 1 Y N 6A	and	HE8C 119	or	HE8C 319
HE 807 ES 17 Y 0 A 6 212 3	127 H 17 K F 1 Y N 6A	127 H 17 X F 1 Y N 6A	and	HE8C 212	or	HE8C 412
HE 807 EN 17 Y 0 A 6 000 3	127 H 17 X M 1 Y R 6A	127 H 17 X M 1 Y R 6A				
HE 807 FN 17 Y 0 A 6 117 3	127 H 17 E M 1 Y R 6A	127 H 17 XL M 1 Y R 6A	and	HE8C 117	or	HE8C 317
HE 807 FN 17 Y 0 A 6 000 3	127 H 17 XL M 1 Y R 6A	127 H 17 XL M 1 Y R 6A				
HE 807 EN 17 Y 0 A 6 212 3	127 H 17 K M 1 Y R 6A	127 H 17 X M 1 Y R 6A	and	HE8C 212	or	HE8C 412
HE 807 ES 17 Z 1 A 6 000 3	127 H 17 X F 1 Z N 6A	127 H 17 X F 1 Z N 6A				
HE 807 FS 17 Z 1 A 6 117 3	127 H 17 E F 1 Z N 6A	127 H 17 XL F 1 Z N 6A	and	HE8C 117	or	HE8C 317
HE 807 FS 17 Z 1 A 6 000 3	127 H 17 XL F 1 Z N 6A	127 H 17 XL F 1 Z N 6A				
HE 807 ES 17 Z 1 A 6 212 3	127 H 17 K F 1 Z N 6A	127 H 17 X F 1 Z N 6A	and	HE8C 212	or	HE8C 412
HE 807 ES 17 Z 1 A 6 213 3	127 H 17 S F 1 Z N 6A	127 H 17 X F 1 Z N 6A	and	HE8C 213	or	HE8C 413
HE 807 EN 17 Z 1 A 6 000 3	127 H 17 X M 1 ZC R 6A	127 H 17 X M 1 ZC R 6A				
HE 807 FN 17 Z 1 A 6 117 3	127 H 17 E M 1 ZC R 6A	127 H 17 XL M 1 ZC R 6A	and	HE8C 117	or	HE8C 317
HE 807 FN 17 Z 1 A 6 000 3	127 H 17 XL M 1 ZC R 6A	127 H 17 XL M 1 ZC R 6A				
HE 807 EN 17 Z 1 A 6 212 3	127 H 17 K M 1 ZC R 6A	127 H 17 X M 1 ZC R 6A	and	HE8C 212	or	HE8C 412
HE 807 EN 17 Z 1 A 6 213 3	127 H 17 S M 1 ZC R 6A	127 H 17 X M 1 ZC R 6A	and	HE8C 213	or	HE8C 413
ES 17-29-41-53 ONLY ON S1						
HE 807 ES 17 S1 1 A 6 000 2	127 H 17 X F 1 X1 N 6A	127 H 17 X F 1 X1 N 6A				
HE 807 FS 17 S1 1 A 6 117 2	127 H 17 E F 1 X1 N 6A	127 H 17 XL F 1 X1 N 6A	and	HE8C 117	or	HE8C 317
HE 807 FS 17 S1 1 A 6 000 2	127 H 17 XL F 1 X1 N 6A	127 H 17 XL F 1 X1 N 6A				
HE 807 ES 17 S1 1 A 6 212 2	127 H 17 K F 1 X1 N 6A	127 H 17 X F 1 X1 N 6A	and	HE8C 212	or	HE8C 412
HE 807 ES 17 S1 1 A 6 213 2	127 H 17 S F 1 X1 N 6A	127 H 17 X F 1 X1 N 6A	and	HE8C 213	or	HE8C 413
ES 17-29-41-53 ONLY ON S2						
HE 807 EN 17 S2 1 A 6 000 2	127 H 17 X M 1 X R 6A	127 H 17 X M 1 X R 6A				
HE 807 FN 17 S2 1 A 6 117 2	127 H 17 E M 1 X R 6A	127 H 17 XL M 1 X R 6A	and	HE8C 117	or	HE8C 317
HE 807 FN 17 S2 1 A 6 000 2	127 H 17 XL M 1 X R 6A	127 H 17 XL M 1 X R 6A				
HE 807 EN 17 S2 1 A 6 212 2	127 H 17 K M 1 X R 6A	127 H 17 X M 1 X R 6A	and	HE8C 212	or	HE8C 412
HE 807 EN 17 S2 1 A 6 213 2	127 H 17 S M 1 X R 6A	127 H 17 X M 1 X R 6A	and	HE8C 213	or	HE8C 413

## Cross references chart HE 807 / 127 H

Connectors with 3 fitting locations (72,84,96 and 144 contacts)									
HE 807 references	Amphenol P/N	Amphenol P/N without fitting	and	Brass fittings 2 extremity + 1 central HE8C...	or	Stainless steel fittings 2 extremity + 1 central HE8C...	or	HE8C...	and HE8C...
<b>ASYMMETRICAL ARRANGEMENTS</b>									
HE 807 FB 84 Y 1 A 3 000 3	127 H 84 XL F 1 YC N 3A	127 H 84 XL F 1 YC N 3A							
HE 807 FB 84 Y 1 A 3 101 3	127 H 84 A F 1 YC N 3A	127 H 84 XL F 1 YC N 3A	and	HE8C 101	and	HE8C 102	or	HE8C 301	and HE8C 302
HE 807 FB 84 Y 1 A 3 102 3	127 H 84 PA F 1 YC N 3A	127 H 84 XL F 1 YC N 3A	and	HE8C 102	and	HE8C 102	or	HE8C 302	and HE8C 302
HE 807 FB 84 Y 1 A 3 103 3	127 H 84 D F 1 YC N 3A	127 H 84 XL F 1 YC N 3A	and	HE8C 103	and	HE8C 102	or	HE8C 303	and HE8C 302
HE 807 FB 84 Y 1 A 3 206 3	127 H 84 IE F 1 YC N 3AB	127 H 84 XL F 1 YC N 3AB	and	HE8C 206	and	HE8C 206	or	HE8C 406	and HE8C 406
HE 807 FB 84 Y 1 A 3 208 3	127 H 84 KE F 1 YC N 3AB	127 H 84 XL F 1 YC N 3AB	and	HE8C 208	and	HE8C 208	or	HE8C 408	and HE8C 408
HE 807 EP 84 Y 1 A 3 000 3	127 H 84 X M 1 YC R 3A	127 H 84 X M 1 YC R 3A							
HE 807 EP 84 Y 1 A 3 101 3	127 H 84 A M 1 YC R 3AB	127 H 84 X M 1 YC R 3A	and	HE8C 101	and	HE8C 102	or	HE8C 301	and HE8C 302
HE 807 FS 84 W 1 B 3 000 2	127 H 84 XL F 1 W3 N 3A	127 H 84 XL F 1 W3 N 3A							
HE 807 FS 84 W 1 B 3 212 2	127 H 84 K F 1 W3 N 3AB	127 H 84 XL F 1 W3 N 3A	and	HE8C 212	and	HE8C 229	or	HE8C 412	and HE8C 429
HE 807 EN 84 W 0 B 3 000 2	127 H 84 X M 1 W3 R 3A	127 H 84 X M 1 W3 N 3A							
HE 807 EN 84 W 0 B 3 212 2	127 H 84 K M 1 W3 R 3A	127 H 84 X M 1 W3 R 3A	and	HE8C 212	and	HE8C 229	or	HE8C 412	and HE8C 429
HE 807 EN 84 W 0 B 3 117 2	127 H 84 E M 1 W3 R 3AB	127 H 84 X M 1 W3 R 3A	and	HE8C 117	and	HE8C 129	or	HE8C 317	and HE8C 329
HE 807 EN 84 Y 0 A 3 000 3	127 H 84 X M 1 Y R 3A	127 H 84 X M 1 Y R 3A							
HE 807 EN 84 Y 0 A 3 101 3	127 H 84 K M 1 Y R 3A	127 H 84 X M 1 Y R 3A	and	HE8C 212	and	HE8C 229	or	HE8C 412	and HE8C 429
HE 807 EN 84 Y 0 A 3 117 3	127 H 84 E M 1 Y R 3AB	127 H 84 X M 1 Y R 3A	and	HE8C 117	and	HE8C 129	or	HE8C 317	and HE8C 329
HE 807 FS 84 Y 0 A 3 000 3	127 H 84 XL F 1 Y N 3A	127 H 84 XL F 1 Y N 3A							
HE 807 FS 84 Y 0 A 3 212 3	127 H 84 K F 1 Y N 3AB	127 H 84 XL F 1 Y N 3A	and	HE8C 212	and	HE8C 229	or	HE8C 412	and HE8C 429
HE 807 EN 84 Z 1 B 3 000 3	127 H 84 X M 1 ZC R 3A	127 H 84 X M 1 ZC R 3A							
HE 807 EN 84 Z 1 B 3 212 3	127 H 84 K M 1 ZC R 3A	127 H 84 X M 1 ZC R 3A	and	HE8C 212	and	HE8C 229	or	HE8C 412	and HE8C 429
HE 807 EN 84 Z 1 B 3 119 3	127 H 84 EF M 1 ZC R 3AB	127 H 84 X M 1 ZC R 3A	and	HE8C 119	and	HE8C 129	or	HE8C 319	and HE8C 329
HE 807 FS 84 Z 1 B 3 000 3	127 H 84 XL F 1 Z N 3A	127 H 84 XL F 1 Z N 3A							
HE 807 FS 84 Z 1 B 3 212 3	127 H 84 K F 1 Z N 3AB	127 H 84 XL F 1 Z N 3A	and	HE8C 212	and	HE8C 229	or	HE8C 412	and HE8C 429
<b>SYMMETRICAL ARRANGEMENTS</b>									
HE 807 FB 56 Y 1 A 10 000 3	127 H 56 XL F 1 YC N 10A	127 H 56 XL F 1 YC N 10A							
HE 807 FB 56 Y 1 A 10 101 3	127 H 56 A F 1 YC N 10A	127 H 56 XL F 1 YC N 10A	and	HE8C 101	and	HE8C 102	or	HE8C 301	and HE8C 302
HE 807 FP 56 Y 1 A 10 000 3	127 H 56 XL M 1 YC R 10A	127 H 56 XL M 1 YC R 10A							
HE 807 FP 56 Y 1 A 10 101 3	127 H 56 X M 1 YC R 10A	127 H 56 XL M 1 YC R 10A	and	HE8C 101	and	HE8C 102	or	HE8C 301	and HE8C 302
HE 807 ES 56 W 0 B 10 000 2	127 H 56 X F 1 W3 N 10A	127 H 56 X F 1 W3 N 10A							
HE 807 ES 56 W 0 B 10 212 2	127 H 56 K F 1 W3 N 10A	127 H 56 X F 1 W3 N 10A	and	HE8C 212	and	HE8C 229	or	HE8C 412	and HE8C 429
HE 807 EN 56 W 0 B 10 000 2	127 H 56 X M 1 W3 R 10A	127 H 56 X M 1 W3 R 10A							
HE 807 FN 56 W 0 B 10 000 2	127 H 56 XL M 1 W3 R 10A	127 H 56 XL M 1 W3 R 10A							
HE 807 ES 56 Y 0 A 10 000 3	127 H 56 X F 1 Y N 10A	127 H 56 X F 1 Y N 10A							
HE 807 FS 56 Y 0 A 10 117 3	127 H 56 E F 1 Y N 10A	127 H 56 XL F 1 Y N 10A	and	HE8C 117	and	HE8C 129	or	HE8C 317	and HE8C 329
HE 807 ES 56 Y 0 A 10 212 3	127 H 56 K F 1 Y N 10A	127 H 56 X F 1 Y N 10A	and	HE8C 212	and	HE8C 229	or	HE8C 412	and HE8C 429
HE 807 EN 56 Y 0 A 10 000 3	127 H 56 X M 1 Y R 10A	127 H 56 X M 1 Y R 10A							
HE 807 EN 56 Y 0 A 10 212 3	127 H 56 K M 1 Y R 10A	127 H 56 X M 1 Y R 10A	and	HE8C 212	and	HE8C 229	or	HE8C 412	and HE8C 429
HE 807 ES 56 Z 1 B 10 000 3	127 H 56 X F 1 Z N 10A	127 H 56 X F 1 Z N 10A							
HE 807 ES 56 Z 1 B 10 213 3	127 H 56 S F 1 Z N 10A	127 H 56 X F 1 Z N 10A	and	HE8C 213	and	HE8C 229	or	HE8C 413	and HE8C 429
HE 807 EN 56 Z 1 B 10 000 3	127 H 56 X M 1 ZC R 10A	127 H 56 M 1 ZC R 10A							
HE 807 FN 56 Z 1 B 10 000 3	127 H 56 XL M 1 ZC R 10A	127 H 56 XL M 1 ZC R 10A							
72 + 6A ONLY ON S1									
HE 807 ES 72 S11 A 6 000 2	127 H 72 X F 1 X1 N 6A	127 H 72 X F 1 X1 N 6A							
HE 807 FS 72 S11 A 6 000 2	127 H 72 XL F 1 X1 N 6A	127 H 72 XL F 1 X1 N 6A							
72 + 6A ONLY ON S2									
HE 807 EN 72 S21 A 6 000 2	127 H 72 X M 1 X R 6A	127 H 72 X M 1 X R 6A							
HE 807 FN 72 S21 A 6 000 2	127 H 72 XL M 1 X R 6A	127 H 72 XL M 1 X R 6A							

# Table of contents

<b>DESCRIPTION &amp; CHARACTERISTICS</b> .....	1
<b>ARRANGEMENTS</b> .....	2
<b>CONTACTS &amp; FITTINGS</b> .....	3
<b>TOOLING</b> .....	3
<b>FITTINGS</b>	
Plugs – Male fittings .....	4
Receptacles – Female fittings .....	5
<b>CONTACTS FOR HE 807 / 127 H CONNECTORS</b>	
Power contacts .....	6
Coaxial contacts .....	7
Optical termini .....	8
<b>PANEL &amp; PCB DRILLING</b>	
For HE 801- HE 804 / 127 connectors .....	9
For HE 807 / 127 H connectors .....	10
<b>ACCESSORIES FOR HE 804 PLUGS</b>	
Hoods for HE 804 plugs .....	12
Locking systems for HE 804 plugs .....	13
<b>CONNECTORS ORDERING INFORMATION</b>	
HE 801 – HE 804 3-row female plugs .....	15
HE 801 – HE 804 3-row male receptacles .....	15
HE 801 – HE 804 2-row female plugs .....	16
HE 801 – HE 804 2-row male receptacles .....	16
HE 801 – HE 804 2-row male plugs .....	17
HE 801 – HE 804 2-row female receptacles .....	17
HE 807 male or female plugs .....	18
HE 807 male or female receptacles .....	19
Fittings .....	19
<b>CROSS REFERENCES</b>	
HE 801 / 127 .....	20
HE 804 / 127 .....	21
HE 807 / 127 H .....	22

Do not hesitate to contact us for further information



## Amphenol

**Amphenol Socapex**  
**Mil/Aero & Industrial Business Unit**

948, Promenade de l'Arve - BP 29  
 F - 74311 Thyez Cedex

Tel.: +33 (0) 4 50 89 28 00 - Fax: +33 (0) 4 50 96 19 41  
<http://www.amphenol.com>

**Sales office in Paris**

Tel.: +33 (0) 1 49 05 30 00 - Fax: +33 (0) 1 49 05 30 43