

HE326XX11

320 X 240 Dots

1. EXTERNAL DIMENSION AND DISPLAY PATTERN

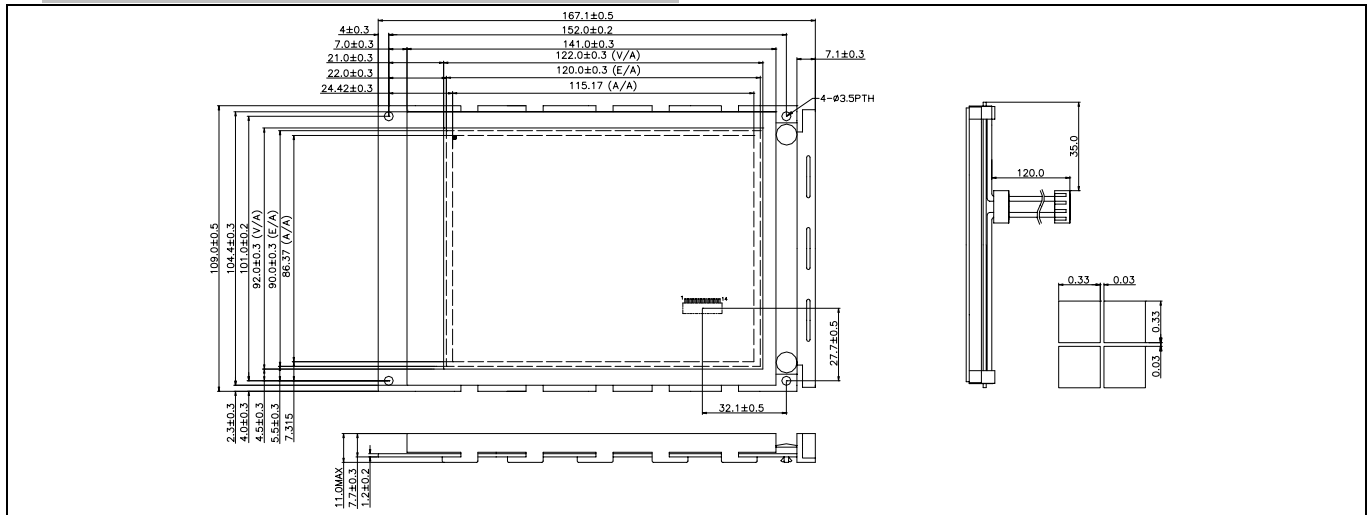

2. MECHANICAL DATA

ITEM	SPECIFICATION	UNIT
Module Size (W×H×T)	167.0×109.0×11.0	mm
Viewing Area (W×H)	122.0×92.0	mm
Number of Dots (W×H)	320×240	dots
Dot Pitch (W×H)	0.36×0.33	mm
Dot Size (W×H)	0.33×0.33	mm

3. ELECTRICAL CHARACTERISTICS (Ta=25 °C)

ITEM	SYMBOL	CONDITION	SPEC. VALUE			UNIT
			MIN.	TYP.	MAX.	
Supply Voltage (Logic)	$V_{DD} - V_{SS}$		2.7	5.0	5.5	V
Supply Current (Logic)	I_{DD}	$V_{DD}=5V$	-	8.7	13.0	mA
Input Voltage	"HIGH"	V_{IH}	-	$0.8V_{DD}$	-	V_{DD}
	"LOW"	V_{IL}	-	0	-	$0.2V_{DD}$
Output Voltage	"HIGH"	V_{OH}	$I_{OH}=-0.4mA$	$V_{DD}-0.4$	-	V
	"LOW"	V_{OL}	$I_{OL}=0.4mA$	-	-	0.4
LCD Operating Voltage	$V_{DD} - V_o$	$V_{DD}=5V, Ta=25 °C$	-	25.0	-	V
Supply Voltage LCD Drive	I_o		-	3.5	5.3	mA

4. PIN CONFIGURATION

PIN	SYMBOL	SIGNAL DESCRIPTION	PIN	SYMBOL	SIGNAL DESCRIPTION
1	DB ₀	Data Bit 0	8	LOAD	Data Latch
2	DB ₁	Data Bit 1	9	CP	Data Shift
3	DB ₂	Data Bit 2	10	V _{DD}	Logic Voltage
4	DB ₃	Data Bit 3	11	V _{SS}	Ground
5	/DISPOFF	Display Off	12	V _{EE}	Power Supply for LCD
6	FLM	Frame Signal	13	V _O	Operating Voltage for LCD (Variable)
7	NC	No Connection	14	FGND	Frame Ground

5. BLOCK DIAGRAM

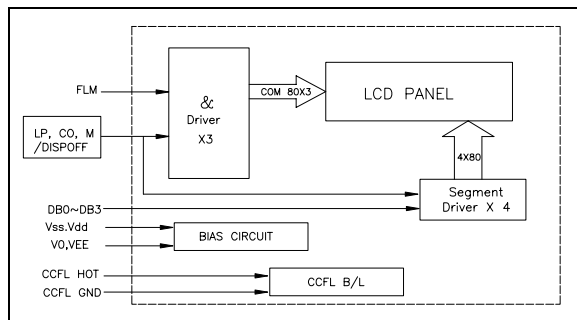

6. BACKLIGHTING CHARACTERISTICS (Ta=25 °C)

CCFL

ITEM	SYMBOL	CONDITION	MIN	TYP	MAX	UNIT
Discharging tube current	I_L	-	-	5		mA
Discharging tube voltage	V_L		-	220		Vrms
Power consumption	P_D			1.2	1.8	W
Lamp supply frequency	f_L			35		K Hz
Luminous	-	$I_F=5mA$	-	75		cd/m ²