

# HE326XX12

320 X 240 Dots

## 1. EXTERNAL DIMENSION AND DISPLAY PATTERN

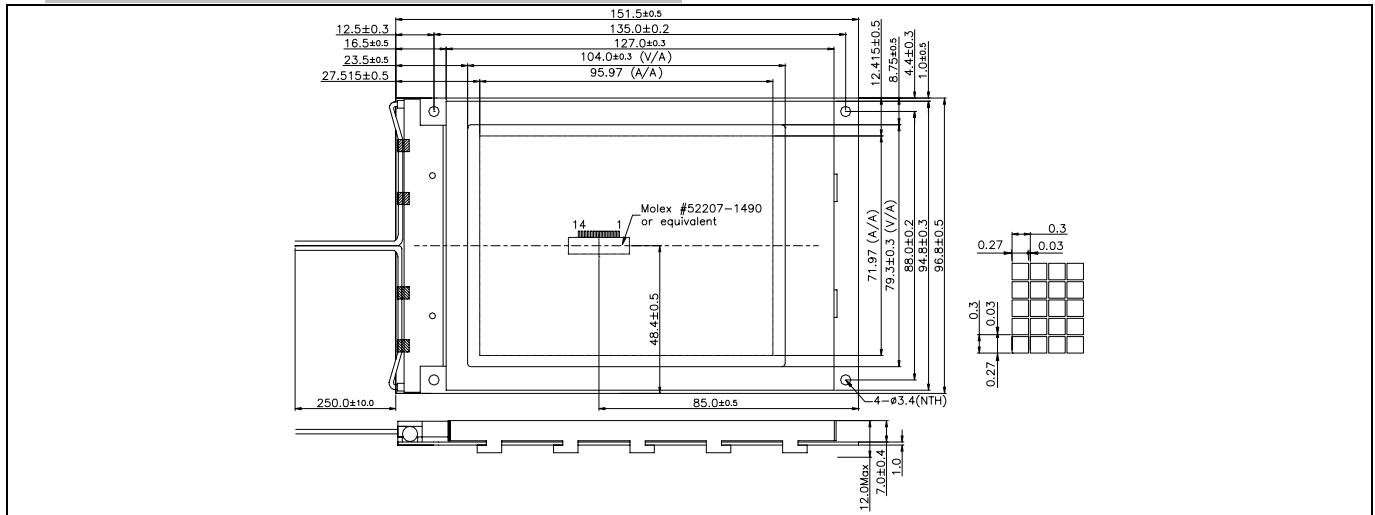

## 2. MECHANICAL DATA

ITEM	SPECIFICATION	UNIT
Module Size (W×H×T)	151.5×96.8×12.0	mm
Viewing Area (W×H)	104.0×79.3	mm
Number of Dots (W×H)	320×240	dots
Dot Pitch (W×H)	0.3×0.3	mm
Dot Size (W×H)	0.27×0.27	mm

## 3. ELECTRICAL CHARACTERISTICS (Ta=25°C)

ITEM	SYMBOL	CONDITION	SPEC. VALUE			UNIT
			MIN.	TYP.	MAX.	
Supply Voltage (Logic)	$V_{DD} - V_{SS}$		2.7	5.0	5.5	V
Supply Current (Logic)	$I_{DD}$	$V_{DD}=5V$	-	9.0	13.5	mA
Input Voltage	"HIGH"	$V_{IH}$	$0.8V_{DD}$	-	$V_{DD}$	V
	"LOW"	$V_{IL}$	0	-	$0.2V_{DD}$	V
Output Voltage	"HIGH"	$V_{OH}$	$I_{OH}=-0.4mA$	$V_{DD}-0.4$	-	V
	"LOW"	$V_{OL}$	$I_{OL}=0.4mA$	-	0.4	V
LCD Operating Voltage	$V_{DD} - V_o$	$V_{DD}=5V, Ta=25^\circ C$	-	22.0	-	V
Supply Voltage LCD Drive	$I_o$		-	5.0	-	mA

## 4. PIN CONFIGURATION

PIN	SYMBOL	SIGNAL DESCRIPTION	PIN	SYMBOL	SIGNAL DESCRIPTION
1	FLM	Frame Signal	9	DB <sub>3</sub>	Data Bit 3
2	M	Control Signal for AC Driving	10	$V_{DD}$	Logic Voltage
3	LOAD	Data Latch	11	$V_{SS}$	Ground
4	CP	Data Shift	12	$V_{EE}$	Power Supply for LCD
5	/DISPOFF	Display Off	13	$V_o$	Operating Voltage for LCD (Variable)
6	DB <sub>0</sub>	Data Bit 0	14	FG	Frame Ground
7	DB <sub>1</sub>	Data Bit 1	15	CCFL Hot	Power Supply for CCFL
8	DB <sub>2</sub>	Data Bit 2	16	CCFL Cold	Power Supply for CCFL

## 5. BLOCK DIAGRAM

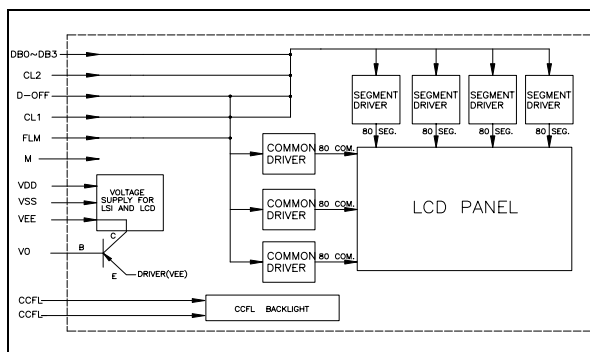

## 6. BACKLIGHTING CHARACTERISTICS (Ta=25°C)

### CCFL

ITEM	SYMBOL	CONDITION	MIN	TYP	MAX	UNIT
Discharging tube current	$I_L$	-	-	5	-	mA
Discharging tube voltage	$V_L$	-	-	300	350	Vrms
Power consumption	$P_D$			1.5		W
Lamp supply frequency	$f_L$			40		k Hz
Luminous	-	$I_L=5.0mA$	-	85		cd/m <sup>2</sup>