



A. HE83540 Introduction

HE83540 is a member of 8-bit Micro-controller series developed by King Billion Electronics Ltd.

Users can chose any one of combination among 【1024 dots LCD Driver + 16 Bit I/O Port】 ... 【896 dots LCD Driver + 24 Bit I/O Port】 etc. The built-in OP comparator can be used with (light 、 voice 、 temperature 、 humility) sensor and used as battery low detection. And the 7-bit current-type D/A converter and PWM device provide the complete speech output mechanism. The built-in DTMF generator can generate the PSTN dialing tone directly. The 512K ROM Size can be used in the storage of large speech data, graphic, text etc. It can be applicable to the medium systems such as Small-Scale Dictionary, Data Bank, Pocket Dialer, Automatic Dialer Machine, Medium Class Educational Toy, Lower Second Voice Recording System etc..

The instruction set of HE83540 are quite easy to learn and simple to use. Only about thirty instructions with four-type addressing mode are provided. Most of instructions take only 3 oscillator clocks (machine cycles). The processing power is enough to most of battery operation system.

B. HE83540 Features

- Operation Voltage : 2.2V – 5.5V
- System Clock : DC ~ 8MHz @ 5.0V
DC ~ 4MHz @ 2.2V
- Internal ROM : 512K Bytes(64K Program ROM, 448K Data ROM)
- Internal RAM : 4K Bytes.
- Dual Clock System : Normal (Fast) clock : 32.768K ~ 8MHz
Slow clock : 32.768KHz
- Operation Mode : DUAL 、 FAST 、 SLOW 、 IDLE 、 SLEEP Mode.
- With WDT (WATCH DOG TIMER) to prevent deadlock condition.



- 16~24 bit Bi-directional I/O port. Mask Option can select PUSH-PULL or OPEN DRAIN output mode for each I/O pin.
- One built-in OP comparator. ◦
- 1024~896 dots LCD driver (B TYPE selectable).
- One 7-bit current-type DAC output.
- PWM device.
- Built-in DTMF Generator.
- Two external interrupts and three internal timer interrupts.
- Three 16-bit timer.
- Instruction set : 32 instructions, 4 addressing mode. 12-bit DATA POINTER for RAM and 19-bit TABLE POINTER for ROM.

C. HE83540 Application

- Applicable to the medium systems such as Small-Scale Dictionary, Data Bank, Pocket Dialer, Automatic Dialer Machine, Medium Class Educational Toy, Lower Seconds Recording System etc..
- Light, voice, temperature, humidity-controlled system, and LCD application.

D. Pin Description

Pin #	Pin name	I/O	Function	Description
104	FXI ,	B,	External fast clock pin. Connecting to crystal or RC to generate 32.768 kHz ~ 8MHz frequency.	Mask option setting : MO_FCK/SCKN= 00 : Slow Clock only 01 : Illegal
103	FXO	O		



107 106	SXI, SXO	I, O	External slow clock pin. Connecting with 32768 Hz crystal or resistor as slow clock and providing clock source for LCD display, TIMER1, Time-Base and other internal blocks.	<p>10 : Dual Clock 11 : Fast Clock only</p> <p>MO_FOSCE = 0 : Internal fast osc. = 1 : External fast osc.</p> <p>MO_FXTAL = 0 : RC osc. for fast clock = 1 : X'tal osc. for fast clock</p> <p>MO_SXTAL = 0 : RC for 32768 Hz clock = 1 : X'tal for 32768 Hz clock</p> <p>Use OP1 and OP2 to switch among different operation mode (NORMAL, SLOW, IDEL and SLEEP). In Dual Clock mode, the main system clock is still the Fast Clock. The 32768 Hz clock is for LCD and Timer 1 only.</p>
102	RSTP_N	I	System Reset.	<p>Level trigger, active low. Except for using this pin, using mask option (MO_PORE=1) could enable IC build-in Power-on reset circuit.</p> <p>Besides, MO_WDTE can set Watch Dog Timer :</p> <p>MO_WDTE=0 : Disable Watch Dog Timer =1 : Enable Watch Dog Timer</p>
105	TSTP_P	I	Test Pin	Please bond this pin and add a test point on PCB for debugging. Leave this pin floating is OK.
121.. 124, 1..4	PRTC[7:0]	B	8-pin bi-directional I/O port.	<p>Mask options :</p> <p>MO_CPP[7..0]=1 ~ Push-pull. =0 ~ Open-drain.</p> <p>Output must be "1" before reading whenever use them as input (No tri-state structure).</p>
113.. 120	PRTD[7:0]	B	8-pin bi-directional I/O port. PRTD[7..2] as wake-up pin. PRTD[7..6] as external interrupt pin.	<p>Mask options :</p> <p>MO_DPP[7..0]=1 ~ Push-pull. =0 ~ Open-drain.</p> <p>Output must be "1" before reading whenever use them as input (No tri-state structure).</p>
				<p>Mask options :</p> <p>MO_LIO14[7..0]=1 ~ LCD Pin.</p>



15.. 22	PRT14[7:0]/ SEG[63:56]	B/ O	8-pin bi-directional I/O port that is shared with LCD segment pin.	=0 ~ I/O Pin. MO_14PP[7..0]=1 ~ Push-pull. =0 ~ Open-drain. Output must be "1" before reading whenever use them as input (No tri-state structure).
14..7, 79.. 86	COM[15:0]	O	LCD COMmon Output	LCD Data filled from 80H, please refer the LCD RAM map.
23.. 78	SEG[55:0]	O	LCD SEGment Output	
88	LC2	B	Charge Pump Switch 1	Add one 0.1 μ F capacitor between LC1 and LC2. Please refer the application circuit.
87	LC1	B	Charge Pump Switch 2	
90	LV3	B	Charge Pump V3	LV3 < 9 Volts.
89	LV1	B	Charge Pump V1	Please refer the application circuit.
91.. 94	LR[4..1]	B	LCD Resister level 4 ~ 1	Please refer the application circuit.
95	LVG	I	LCD Virtual Ground	Please refer the application circuit.
5	PWMP	O	The PWM positive output can drive speaker or buzzer directly.	Set the bit2 of VOC register as one to turn on PWM.
6	PWMN	O	The PWM positive output can drive speaker or buzzer directly.	Set the bit2 of VOC register as one to turn on PWM.
97	VO	O	D/A output.	Bit 1 of VOC = '1', Turn on DA
98	DAO	O	DAC Voice Output	Set the bit1(DA=1) of VOC register to turn on DAC with VO output.
99	OPIN	I	OPAMP negative input pin.	Built-in OP comparator. Set Bit 0 of VOC = '1', Turn on OP
100	OPIP	I	OPAMP positive input pin.	
101	OPO	O	OPAMP output pin.	
110	DTMFO	O	DTMF Output	Through PRT12 we can turn on/off DTMF and write data. Using Mask Option MO_DTMFSCK set the clock source of DTMF block. MO_DTMFSCK=0 ; Clock Source=3.579545 MHz =1 ; Clock Source=32768 Hz



109	MUTE	O	MUTE Output for Dialer	User can turn on/off MUTE pin by port12.
111	SDO	O	Serial Data Output	We can turn on/off SDO block or write data by port12.
112	KEYTONE	O	1024-Hz 50% duty square wave	User can turn on/off key tone by port12.
108	VDD	P	Positive Power Input	
96	GND	P	Power Ground Input	

E. LCD RAM Map

Page	SEG	SEG	SEG	SEG	SEG	SEG	SEG	SEG
0	[7:0]	[15:8]	[23:16]	[31:24]	[39:32]	[47:40]	[55:48]	[63:56]
COM0	80H	90H	A0H	B0H	C0H	D0H	E0H	F0H
COM1	81H	91H	A1H	B1H	C1H	D1H	E1H	F1H
COM2	82H	92H	A2H	B2H	C2H	D2H	E2H	F2H
:	:	:	:	:	:	:	:	:
:	:	:	:	:	:	:	:	:
COM13	8DH	9DH	ADH	BDH	CDH	DDH	EDH	FDH
COM14	8EH	9EH	AEH	BEH	CEH	DEH	EEH	FEH
COM15	8FH	9FH	AFH	BFH	CFH	DFH	EFH	FFH



G. Bonding Pad Location

PIN Number	PIN Name	X Coordinate	Y Coordinate	PIN Number	PIN Name	X Coordinate	Y Coordinate
1	PRTC[3]	X= -2115.45	Y= 1700.75	63	SEG[15]	X= 2130.30	Y= -1776.75
2	PRTC[2]	X= -2115.45	Y= 1585.25	64	SEG[14]	X= 2130.30	Y= -1661.25
3	PRTC[1]	X= -2115.45	Y= 1469.75	65	SEG[13]	X= 2130.30	Y= -1545.75
4	PRTC[0]	X= -2115.45	Y= 1354.25	66	SEG[12]	X= 2130.30	Y= -1430.25
5	PWMP	X= -2115.45	Y= 1214.50	67	SEG[11]	X= 2130.30	Y= -1314.75
6	PWMN	X= -2115.45	Y= 1051.15	68	SEG[10]	X= 2130.30	Y= -1199.25
7	COM[8]	X= -2115.45	Y= 912.05	69	SEG[9]	X= 2130.30	Y= -1083.75
8	COM[9]	X= -2115.45	Y= 796.55	70	SEG[8]	X= 2130.30	Y= -968.25
9	COM[10]	X= -2115.45	Y= 681.05	71	SEG[7]	X= 2130.30	Y= -852.75
10	COM[11]	X= -2115.45	Y= 565.55	72	SEG[6]	X= 2130.30	Y= -737.25
11	COM[12]	X= -2115.45	Y= 450.05	73	SEG[5]	X= 2130.30	Y= -621.75
12	COM[13]	X= -2115.45	Y= 334.55	74	SEG[4]	X= 2130.30	Y= -506.25
13	COM[14]	X= -2115.45	Y= 219.05	75	SEG[3]	X= 2130.30	Y= -390.75
14	COM[15]	X= -2115.45	Y= 103.55	76	SEG[2]	X= 2130.30	Y= -275.25
15	PRT14[7]	X= -2115.45	Y= -11.95	77	SEG[1]	X= 2130.30	Y= -159.75
16	PRT14[6]	X= -2115.45	Y= -127.45	78	SEG[0]	X= 2130.30	Y= -44.25
17	PRT14[5]	X= -2115.45	Y= -242.95	79	COM[7]	X= 2130.30	Y= 71.25
18	PRT14[4]	X= -2115.45	Y= -358.45	80	COM[6]	X= 2130.30	Y= 186.75
19	PRT14[3]	X= -2115.45	Y= -473.95	81	COM[5]	X= 2130.30	Y= 302.25
20	PRT14[2]	X= -2115.45	Y= -589.45	82	COM[4]	X= 2130.30	Y= 417.75
21	PRT14[1]	X= -2115.45	Y= -704.95	83	COM[3]	X= 2130.30	Y= 533.25
22	PRT14[0]	X= -2115.45	Y= -820.45	84	COM[2]	X= 2130.30	Y= 648.75



23	SEG[55]	X= -2115.45	Y= -935.95	85	COM[1]	X= 2130.30	Y= 764.25
24	SEG[54]	X= -2115.45	Y= -1051.45	86	COM[0]	X= 2130.30	Y= 879.75
25	SEG[53]	X= -2115.45	Y= -1166.95	87	LC1	X= 2130.30	Y= 995.25
26	SEG[52]	X= -2115.45	Y= -1282.45	88	LC2	X= 2130.30	Y= 1110.75
27	SEG[51]	X= -2115.45	Y= -1397.95	89	LV1	X= 2130.30	Y= 1226.25
28	SEG[50]	X= -2115.45	Y= -1513.45	90	LV3	X= 2130.30	Y= 1341.75
29	SEG[49]	X= -2115.45	Y= -1628.95	91	LR4	X= 2130.30	Y= 1457.25
30	SEG[48]	X= -2115.45	Y= -1744.45	92	LR3	X= 2130.30	Y= 1572.75
31	SEG[47]	X= -1786.25	Y= -1856.95	93	LR2	X= 1795.05	Y= 1828.60
32	SEG[46]	X= -1670.75	Y= -1856.95	94	LR1	X= 1679.55	Y= 1828.60
33	SEG[45]	X= -1555.25	Y= -1856.95	95	LVG	X= 1564.05	Y= 1828.60
34	SEG[44]	X= -1439.75	Y= -1856.95	96	GND	X= 1448.55	Y= 1828.60
35	SEG[43]	X= -1324.25	Y= -1856.95	97	VO	X= 1333.05	Y= 1828.60
36	SEG[42]	X= -1208.75	Y= -1856.95	98	DAO	X= 1217.55	Y= 1828.60
37	SEG[41]	X= -1093.25	Y= -1856.95	99	OPIN	X= 1102.05	Y= 1828.60
38	SEG[40]	X= -977.75	Y= -1856.95	100	OPIP	X= 986.55	Y= 1828.60
39	SEG[39]	X= -862.25	Y= -1856.95	101	OPO	X= 871.05	Y= 1828.60
40	SEG[38]	X= -746.75	Y= -1856.95	102	RSTP_N	X= 755.55	Y= 1828.60
41	SEG[37]	X= -631.25	Y= -1856.95	103	FXO	X= 640.05	Y= 1828.60
42	SEG[36]	X= -515.75	Y= -1856.95	104	FXI	X= 524.55	Y= 1828.60
43	SEG[35]	X= -400.25	Y= -1856.95	105	TSTP_P	X= 409.05	Y= 1828.60
44	SEG[34]	X= -284.75	Y= -1856.95	106	SXO	X= 293.55	Y= 1828.60
45	SEG[33]	X= -169.25	Y= -1856.95	107	SXI	X= 178.05	Y= 1828.60
46	SEG[32]	X= -53.75	Y= -1856.95	108	VDD	X= 62.55	Y= 1828.60
47	SEG[31]	X= 61.75	Y= -1856.95	109	MUTE	X= -52.95	Y= 1828.60
48	SEG[30]	X= 177.25	Y= -1856.95	110	DTMFO	X= -168.45	Y= 1828.60
49	SEG[29]	X= 292.75	Y= -1856.95	111	SDO	X= -283.95	Y= 1828.60
50	SEG[28]	X= 408.25	Y= -1856.95	112	KEYTONE	X= -399.45	Y= 1828.60



51	SEG[27]	X= 523.75	Y= -1856.95	113	PRTD[7]	X= -514.95	Y= 1828.60
52	SEG[26]	X= 639.25	Y= -1856.95	114	PRTD[6]	X= -630.45	Y= 1828.60
53	SEG[25]	X= 754.75	Y= -1856.95	115	PRTD[5]	X= -745.95	Y= 1828.60
54	SEG[24]	X= 870.25	Y= -1856.95	116	PRTD[4]	X= -861.45	Y= 1828.60
55	SEG[23]	X= 985.75	Y= -1856.95	117	PRTD[3]	X= -976.95	Y= 1828.60
56	SEG[22]	X= 1101.25	Y= -1856.95	118	PRTD[2]	X= -1092.45	Y= 1828.60
57	SEG[21]	X= 1216.75	Y= -1856.95	119	PRTD[1]	X= -1207.95	Y= 1828.60
58	SEG[20]	X= 1332.25	Y= -1856.95	120	PRTD[0]	X= -1323.45	Y= 1828.60
59	SEG[19]	X= 1447.75	Y= -1856.95	121	PRTC[7]	X= -1438.95	Y= 1828.60
60	SEG[18]	X= 1563.25	Y= -1856.95	122	PRTC[6]	X= -1554.45	Y= 1828.60
61	SEG[17]	X= 1678.75	Y= -1856.95	123	PRTC[5]	X= -1669.95	Y= 1828.60
62	SEG[16]	X= 1794.25	Y= -1856.95	124	PRTC[4]	X= -1785.45	Y= 1828.60



H. DC/AC Characteristics

Absolute Maximum Rating

Item	Sym.	Rating	Condition
Supply Voltage	V_{dd}	-0.5V ~ 8V	
Input Voltage	V_{in}	-0.5V ~ $V_{dd}+0.5V$	
Output Voltage	V_o	-0.5V ~ $V_{dd}+0.5V$	
Operating Temperature	T_{op}	0°C ~ 70°C	
Storage Temperature	T_{st}	-50°C ~ 100°C	

Recommended Operating Conditions

Item	Sym.	Rating	Condition
Supply Voltage	V_{dd}	2.2V ~ 5.5V	
Input Voltage	V_{ih}	0.9 V_{dd} ~ V_{dd}	
	V_{il}	0.0V ~ 0.1 V_{dd}	
Operating Frequency	F_{max}	8MHz	$V_{dd}=5.0V$
		4MHz	$V_{dd}=2.2V$
Operating Temperature	T_{op}	0°C ~ 70°C	
Storage Temperature	T_{st}	-50°C ~ 100°C	



Testing Condition : TEMP=25°C, VDD=3V+/-10%, GND=0V

	PARAMETER		CONDITION	MIN	TYP	MAX	UNIT
I _{Fast}	NORMAL Mode Current	System	2M ext. R/C		0.75	1	mA
I _{Slow}	SLOW Mode Current	System	32.768K X'tal LCD Disable		10	20	μA
I _{Idle}	IDLE Mode Current	System	32.769K X'tal LCD Disable		6	10	μA
I _{LCD}	Extra Current if LCD ON	System	LCD Enable, LCD option=300Kohm Voltage-doubler OFF		12	20	μA
			LCD Enable, LCD option=30Kohm, Voltage-doubler ON		100	120	
I _{Sleep}	Sleep Mode Current	System				1	μA
I _{oHPWM}	PWM Output Drive Current	PWMP, PWMN*2	V _{DD} =3V; V _{oh} =2V	12	15		mA
I _{oLPWM}	PWM Output Sink Current	PWMP, PWMN*2	V _{DD} =3V; V _{oL} =1V	33	40		mA
I _{oVO}	DAC Output Current	VO, DAO	V _{DD} =3V; VO=0~2V, Data=7F	2.5	3		mA
V _{iH}	Input High Voltage	I/O pins		0.8 V _{DD}			V
V _{iL}	Input Low Voltage	I/O pins				0.2 V _{DD}	V
V _{hys}	Input Hysteresis Width	I/O, RSTP_N	Threshold=2/3V _{DD} (input from low to high) Threshold=1/3V _{DD} (input from high to low)		1/3 V _{DD}		V
I _{oH}	Output Drive Current	I/O pull-high*1	V _{oL} =2.0V	50			μA
I _{oL_1}	Output Sink Current	I/O pull-low*1	V _{oL} =0.4V	1.0			mA
I _{iL_1}	Input Low Current	RSTP_N	V _{iL} =GND, pull high Internally		20		μA
I _{iL_2}	Input Low Current	I/O	V _{iL} =GND, if pull high Internally by user		100		μA

Note: *1: Drive Current Spec. for Push-Pull I/O port only

Sink Current Spec. for both Push-Pull and Open-Drain I/O port.

*2: This Spec. base on one driver only. There are five build-in driver, so user just multiply the number of driver he used to one driver current to get the total amount of current. ($I_{oHPWM} \cdot I_{oLPWM} * N$; $N=0,1,2,3,4,5$)

I. Application Circuit

Twice Charge Pump is selected
 LCD Max. Voltage=LV3=3/2*VDD

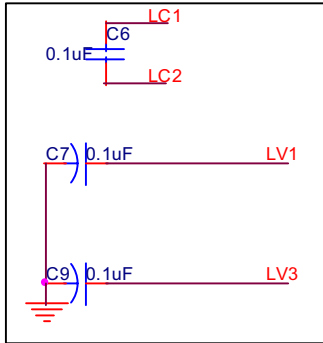

Twice Charge Pump is selected
 LCD Max. Voltage=LV3=VDD

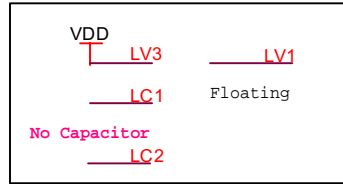

No External Parts is necessary if user adopt Internal Fast RC Clock

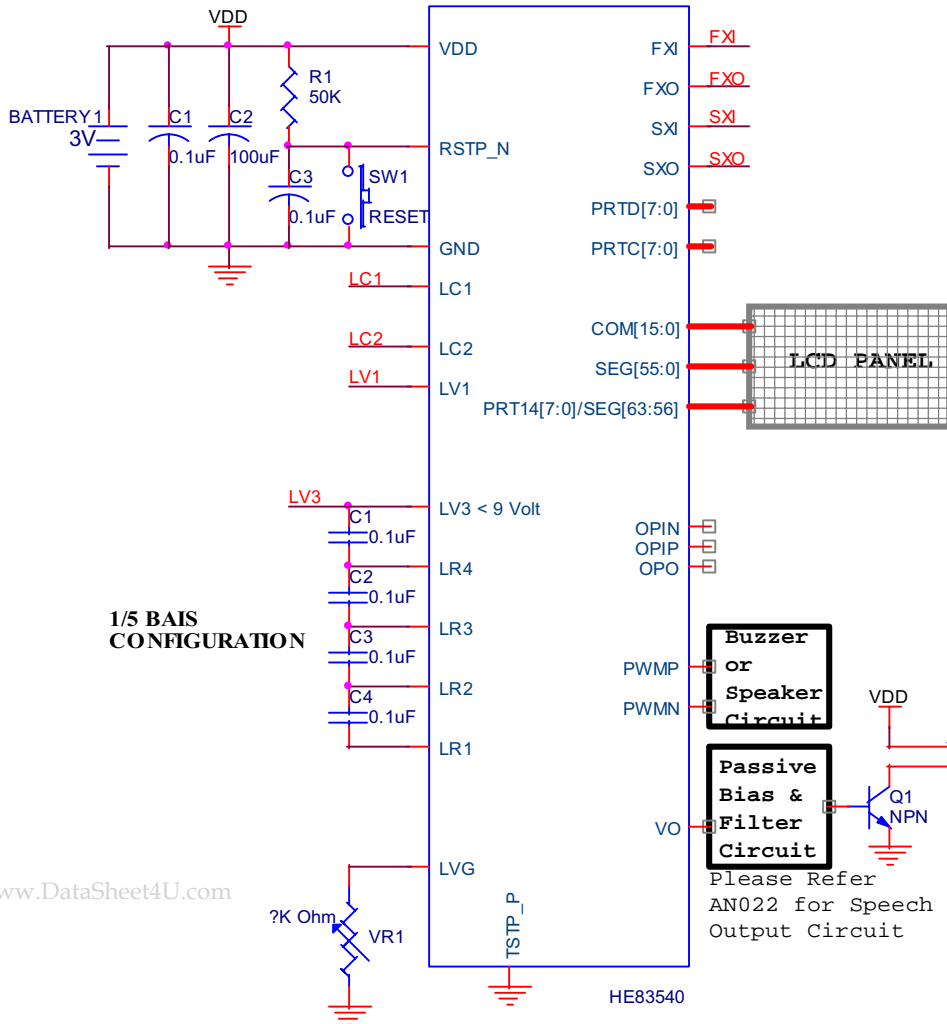

External Fast Clock: Crystal osc.

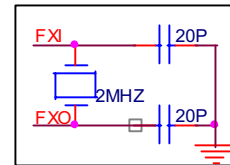

External Fast Clock: RC osc.

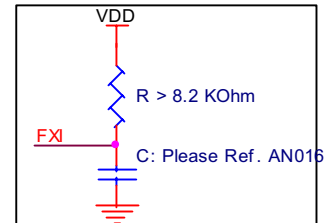

External Slow Clock: Crystal osc.

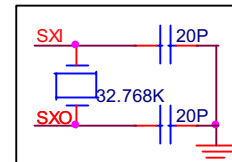

External Slow Clock: RC osc.

