



HER801 THRU HER806

8 A Glass Passivated High Efficiency Rectifiers

Voltage Range 50 to 600 Volts
Current 8.0 Amperes

Features

- * Low forward voltage drop
- * High current capability
- * High reliability
- * High surge current capability

Mechanical Data

- * Case: Molded plastic
- * Epoxy: UL94V-0 rate flame retardant
- * Terminals: Leads, solderable per MIL-STD-202, Method 208 guaranteed
- * Polarity: As marked
- * High temperature soldering guaranteed:
250°C/10 seconds .16", (4.06mm) from case.
- * Weight: 2.24 grams

TO-220A

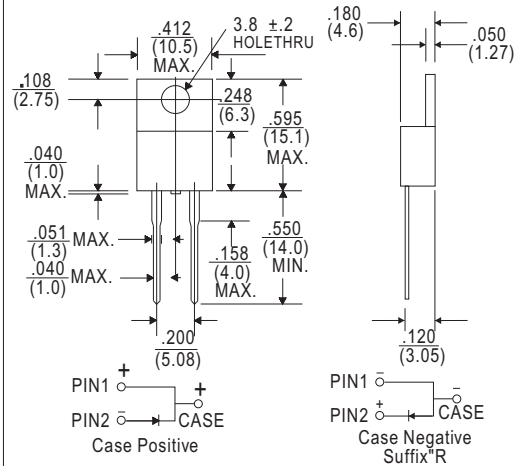

Dimensions in inches and (millimeters)

Maximum Ratings and Electrical Characteristics

Rating at 25°C ambient temperature unless otherwise specified. Single phase, half wave, 60 Hz, resistive or inductive load. For capacitive load, derate current by 20%

Type Number	HER 801	HER 802	HER 803	HER 804	HER 805	HER 806	Units
Maximum Recurrent Peak Reverse Voltage	50	100	200	300	400	600	V
Maximum RMS Voltage	35	70	140	210	280	420	V
Maximum DC Blocking Voltage	50	100	200	300	400	600	V
Maximum Average Forward Rectified Current, 375" (9.5mm) Lead Length @ T _c =100°C	8.0						A
Peak Forward Surge Current, 8.3 ms Single Half Sine-wave Superimposed on Rated Load (JEDEC method)	125						A
Maximum Instantaneous Forward Voltage @ 8.0A	1.0			1.3		1.7	V
Maximum DC Reverse Current @ T _a =25°C	10.0						uA
At Rated DC Blocking Voltage @ T _a =125°C	100						uA
Maximum Reverse Recovery Time (Note 1)	50				80		nS
Typical Junction Capacitance (Note 2)	80				50		pF
Typical Thermal Resistance R _θ JC (Note 3)	2.2						°C/W
Operating Temperature Range T _j	-55 to +150						°C
Storage Temperature Range T _{STG}	-55 to +150						°C

Notes:

1. Reverse Recovery Test Conditions: I_F=0.5A, I_R=1.0A, I_{RR}=0.25A
2. Measured at 1 MHz and Applied Reverse Voltage of 4.0 Volts D.C.
3. Thermal Resistance from Junction to Case Mounting on Heatsink.

[Http://www.upm.com.tw](http://www.upm.com.tw)

E-mail: upm.tw@msa.hinet.net



HER801 THRU HER806

8 A Glass Passivated High Efficiency Rectifiers

Voltage Range 50 to 600 Volts

Current 8.0 Amperes

RATINGS AND CHARACTERISTIC CURVES (HER801 THRU HER806)

FIG . 1 -REVERSE RECOVERY TIME CHARACTERISTIC AND TEST CIRCUIT DIAGRAM

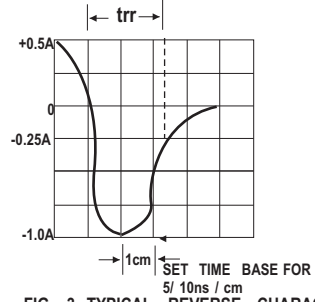
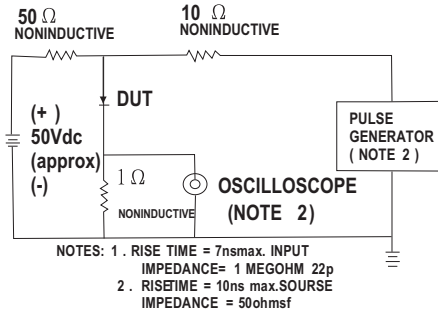

FIG . 3 -TYPICAL REVERSE CHARACTERISTICS

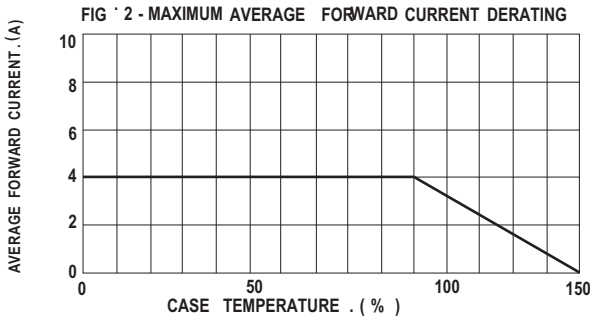

FIG . 2 - MAXIMUM AVERAGE FORWARD CURRENT DERATING

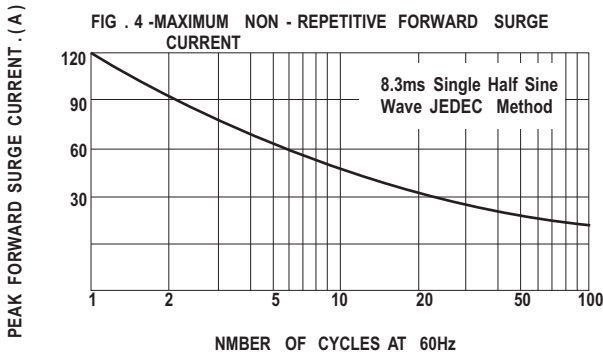

FIG . 4 -MAXIMUM NON - REPETITIVE FORWARD SURGE CURRENT

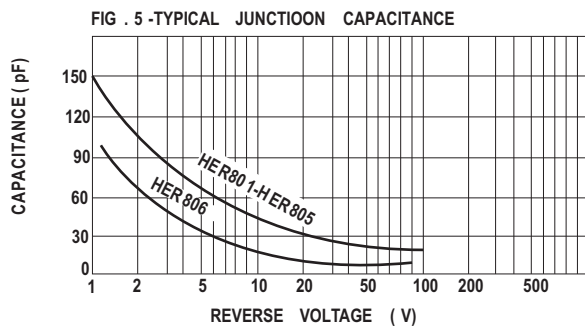

FIG . 5 -TYPICAL JUNCTION CAPACITANCE

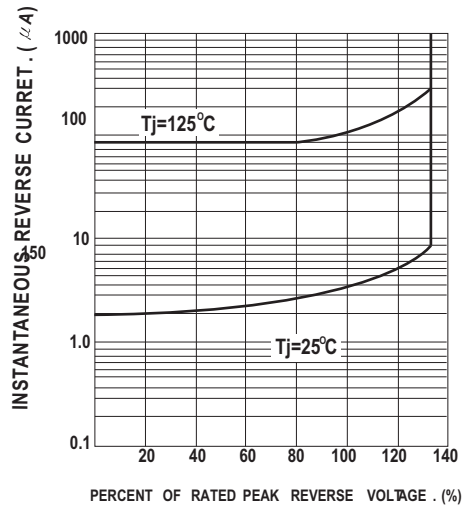

FIG . 6 -TYPICAL FRWARD CHARACTERISTICS

