

FRED Ultrafast Soft Recovery Diode 15A/600V



FEATURES

- Ultrafast recovery
- Ultrasoft recovery
- Very low I_{RRM}
- Very low Q_{rr}
- Specified at operating conditions
- Lead (Pb)-free
- Designed and qualified for industrial level
- Planar FRED Chip

BENEFITS

- Reduced RFI and EMI
- Reduced power loss in diode and switching transistor
- Higher frequency operation
- Reduced snubbing
- Reduced parts count

DESCRIPTION

HFA15TB60 is a state of the art ultrafast recovery diode. Employing the latest in epitaxial construction and advanced processing techniques it features a superb combination of characteristics which result in performance which is unsurpassed by any rectifier previously available. With basic ratings of 600V and 15A continuous current, the HFA15TB60 is especially well suited for use as the companion diode for IGBTs and MOSFETs. In addition to ultrafast recovery time, the FRED product line features extremely low values of peak recovery current (I_{RRM}) and does not exhibit any tendency to “snap-off” during the t_b portion of recovery. The FRED features combine to offer designers a rectifier with lower noise and significantly lower switching losses in both the diode and the switching transistor. These FRED advantages can help to significantly reduce snubbing, component count and heatsink sizes. The FRED HFA15TB60 is ideally suited for applications in power supplies and conversion systems (such as inverters), motor drives, and many other similar applications where high speed, high efficiency is needed.

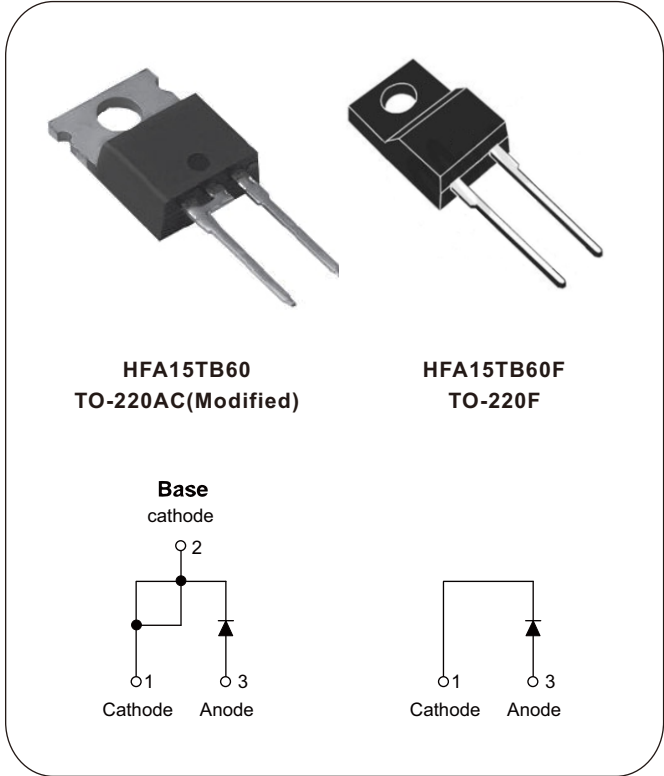

PRODUCT SUMMARY	
V_R	600 V
V_F at 15A at 25 °C	1.60V
$I_{F(AV)}$	15 A
t_{rr} (typical)	21 ns
T_J (maximum)	150 °C
Q_{rr}	84 nC
$di_{(rec)M}/dt$	188 A/ μ s

ABSOLUTE MAXIMUM RATINGS				
PARAMETER	SYMBOL	TEST CONDITIONS	VALUES	UNITS
Cathode to anode voltage	V_R		600	V
Maximum continuous forward current	I_F	$T_C = 100\text{ °C}$ (TO-220AC)	15	A
		$T_C = 70\text{ °C}$ (TO-220F)		
Single pulse forward current	I_{FSM}		150	
Maximum power dissipation	P_D	$T_C = 25\text{ °C}$	74	W
		$T_C = 100\text{ °C}$	29	
Operating junction and storage temperature range	T_J, T_{Stg}		- 55 to 150	°C

Nell High Power Products

ELECTRICAL SPECIFICATIONS ($T_J = 25\text{ }^\circ\text{C}$ unless otherwise specified)						
PARAMETER	SYMBOL	TEST CONDITIONS	MIN.	TYP.	MAX.	UNITS
Cathode to anode breakdown voltage	V_{BR}	$I_R = 100\text{ }\mu\text{A}$	600	-	-	V
Maximum forward voltage	V_{FM}	$I_F = 15\text{ A}$	-	1.35	1.60	
		$I_F = 30\text{ A}$	-	1.60	1.90	
		$I_F = 15\text{ A}, T_J = 125\text{ }^\circ\text{C}$	-	1.20	1.50	
Maximum reverse leakage current	I_{RM}	$V_R = V_R\text{ rated}$	-	1.0	10	μA
		$T_J = 125\text{ }^\circ\text{C}, V_R = V_R\text{ rated}$	-	400	1000	
Junction capacitance	C_T	$V_R = 200\text{ V}$	-	25	50	pF
Series inductance	L_S	Measured lead to lead 5 mm from package body	-	8	-	nH

DYNAMIC RECOVERY CHARACTERISTICS PERLEG ($T_J = 25\text{ }^\circ\text{C}$ unless otherwise specified)						
PARAMETER	SYMBOL	TEST CONDITIONS	MIN.	TYP.	MAX.	UNITS
Reverse recovery time	t_{rr}	$I_F = 0.5\text{ A}, I_R = 1.0\text{ A}, I_{RR} = 0.25\text{ A (RG\#1 CKT)}$	-	26	32	ns
		$I_F = 1.0\text{ A}, dI_F/dt = 200\text{ A}/\mu\text{s}, V_R = 30\text{ V}, T_J = 25\text{ }^\circ\text{C}$	-	21	-	
	t_{rr1}	$T_J = 25\text{ }^\circ\text{C}$	-	42	60	
	t_{rr2}	$T_J = 125\text{ }^\circ\text{C}$	-	74	120	
Peak recovery current	I_{RRM1}	$T_J = 25\text{ }^\circ\text{C}$	-	4.0	6.0	A
	I_{RRM2}	$T_J = 125\text{ }^\circ\text{C}$	-	6.5	10	
Reverse recovery charge	Q_{rr1}	$T_J = 25\text{ }^\circ\text{C}$	-	84	180	nC
	Q_{rr2}	$T_J = 125\text{ }^\circ\text{C}$	-	241	600	
Peak rate of fall of recovery current during t_b	$dl_{(rec)M}/dt1$	$T_J = 25\text{ }^\circ\text{C}$	-	188	-	A/ μs
	$dl_{(rec)M}/dt2$	$T_J = 125\text{ }^\circ\text{C}$	-	160	-	

THERMAL - MECHANICAL SPECIFICATIONS						
PARAMETER	SYMBOL	TEST CONDITIONS	MIN.	TYP.	MAX.	UNITS
Lead temperature	T_{lead}	0.063" from case (1.6 mm) for 10 s	-	-	300	$^\circ\text{C}$
Thermal resistance, junction to case	R_{thJC}	TO-220AC	-	-	1.70	K/W
		TO-220F	-	-	2.50	
Thermal resistance, junction to lead	R_{thJL}	TO-220AC	-	-	2.25	
		TO-220F	-	-	3.50	
Thermal resistance, case to heatsink	R_{thCS}	Mounting surface, flat, smooth and gered	-	0.5	-	
Weight			-	2	-	g
			-	0.07	-	oz.
Mounting torque			6	-	12	kgf . cm (lb . in)
			(5)	-	(10)	
Marking device		Case style TO-220AC Modified	HFA15TB60			
		Case style TO-220F Modified	HFA15TB60F			

Fig.1 Maximum forward voltage drop vs. Instantaneous forward current

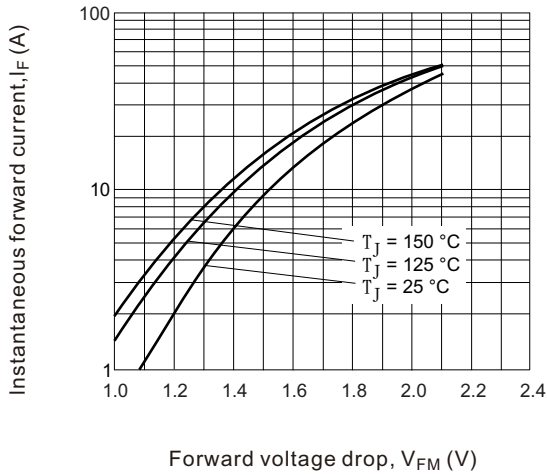

Fig.2 Typical reverse current vs. reverse voltage

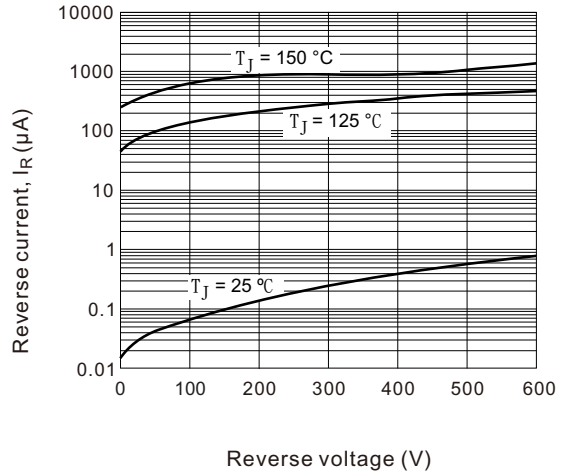

Fig.3 Typical Junction Capacitance vs. Reverse Voltage

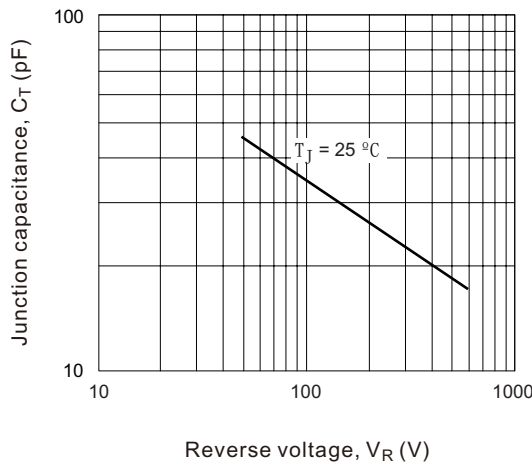

Fig.4-1 Maximum thermal Impedance Z_{thJC} characteristics (for HFA15TB60)

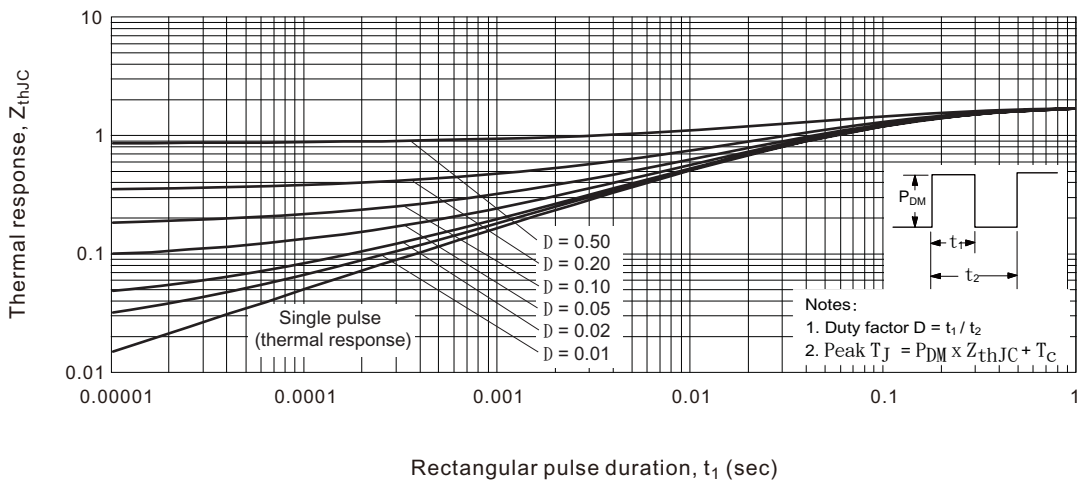

Fig.4-2 Maximum thermal Impedance Z_{thJC} characteristics (for HFA15TB60F)

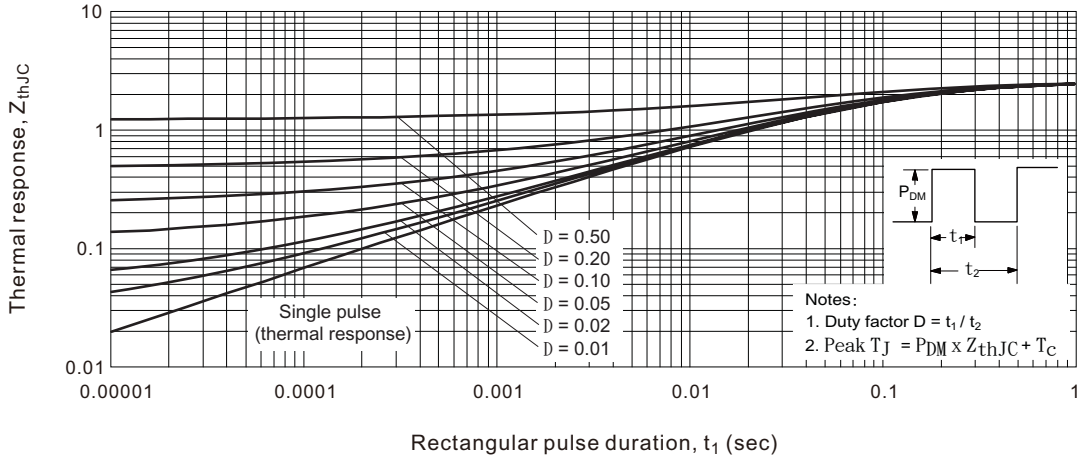

Fig.5 Typical reverse recovery time vs. di_F/dt

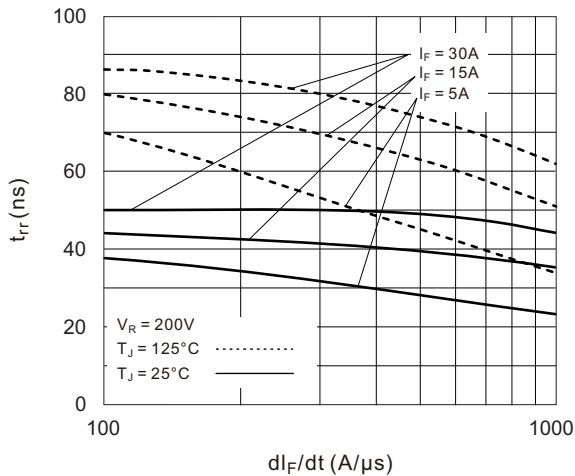

Fig.6 Typical recovery current vs. di_F/dt

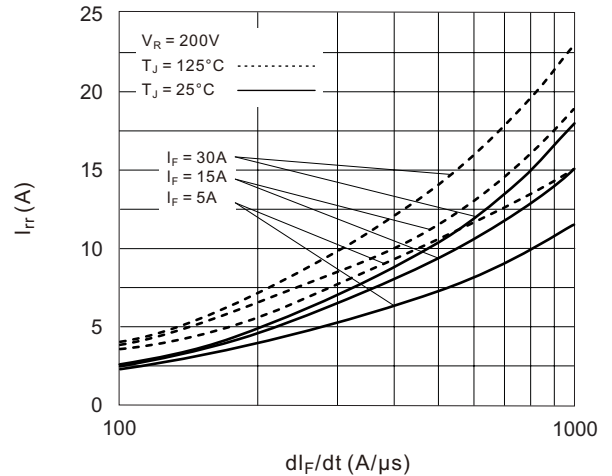

Fig.7 Typical stored charge vs. di_F/dt

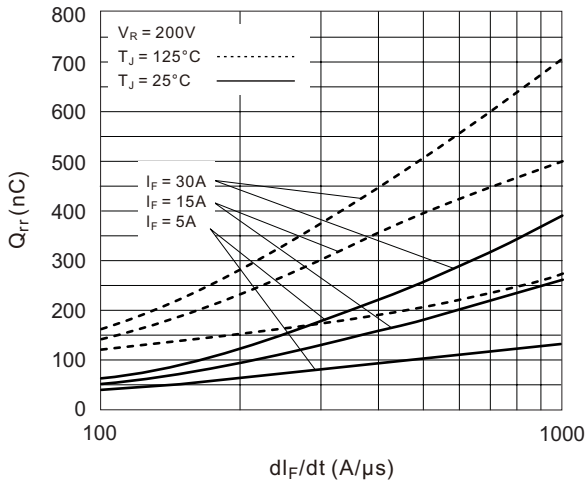

Fig.8 Typical $di_{(rec)M}/dt$ vs. di_F/dt

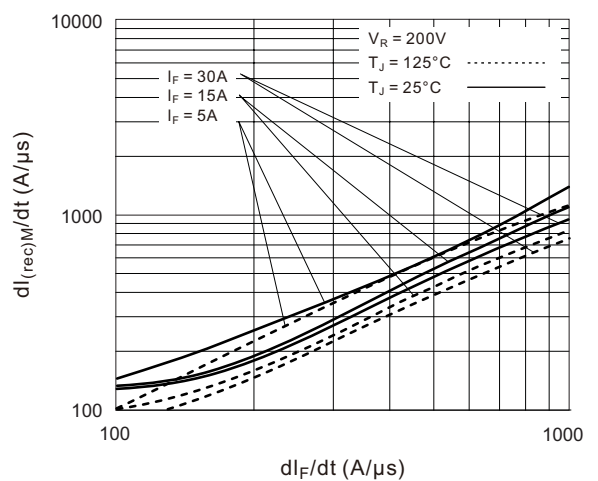

Fig.9 Reverse Recovery Parameter Test Circuit

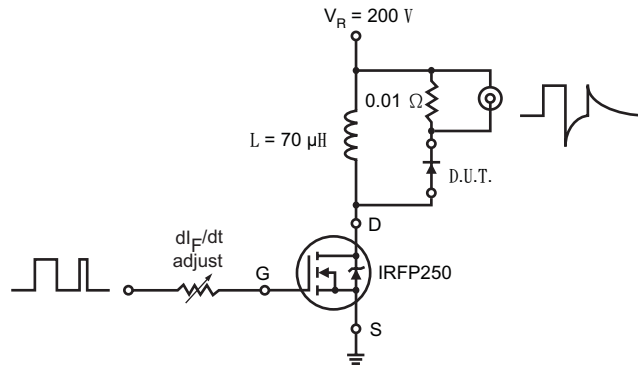
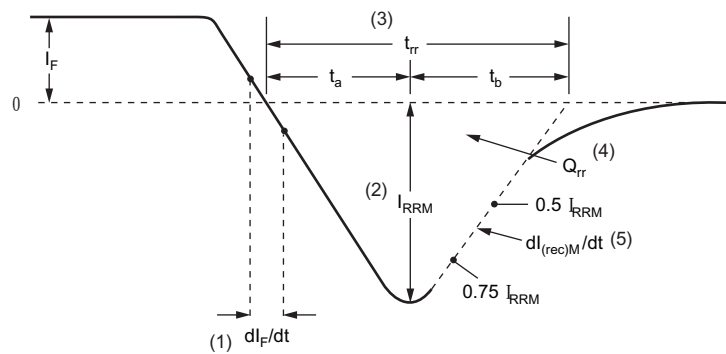

Fig.10 Reverse Recovery Waveform and Definitions



- (1) dI_F/dt - rate of change of current through zero crossing
- (2) I_{RRM} - peak reverse recovery current
- (3) t_{rr} - reverse recovery time measured from zero crossing point of negative going I_F to point where a line passing through $0.75 I_{RRM}$ and $0.50 I_{RRM}$ extrapolated to zero current.
- (4) Q_{rr} - area under curve defined by t_{rr} and I_{RRM}
- (5) $dI_{(rec)M}/dt$ - peak rate of change of current during t_b portion of t_{rr}

$$Q_{rr} = \frac{t_{rr} \times I_{RRM}}{2}$$

ORDERING INFORMATION TABLE

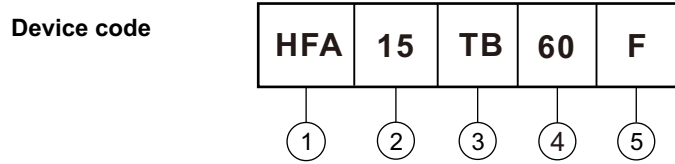

- 1 - FRED family
- 2 - Current rating (15 = 15 A)
- 3 - Package : TB = TO-220
- 4 - Voltage rating (60 = 600 V)
- 5 - None = TO-220AC Modified
F = TO-220F Modified (Full-Pak)

