

## Fiber Optic LAN Components High Speed VCSEL 2.5Gbps

# HFE4090-321

### FEATURES

- Designed for drive currents between 5 and 15 mA
- Optimized for low dependence of electrical properties over temperature
- High speed  $\geq 1$  GHz

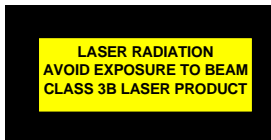

The HFE4090-321 is a high-performance 850 nm VCSEL (Vertical Cavity Surface-Emitting Laser) packaged for high-speed data communications.

The HFE4090-321 is a high radiance VCSEL designed to convert electrical current into optical power that can be used in fiber optic communications and other applications. As the current varies above threshold, the light intensity increases proportionally.

The HFE4090-321 is designed to be used with inexpensive silicon or gallium arsenide detectors, but excellent performance can also be achieved with some indium gallium arsenide detectors.

The low drive current requirement makes direct drive from PECL (Positive Emitter Coupled Logic) or EML (Emitter Coupled Logic) gates possible and eases driver design.

The HFE4090-321 is designed to interface with 50/125 and 62.5/125  $\mu\text{m}$  multimode fiber. It produces circularly symmetric, non-astigmatic, narrow divergence beams that, with appropriate lensing, fiber couple all of the emitter power.

# Fiber Optic LAN Components

## High Speed VCSEL 2.5Gbps

HFE4090-321

### ABSOLUTE MAXIMUM RATINGS

Parameter	Rating
Storage Temperature	-40 to +100 °C
Operating Temperature	0 to +70 °C
Lead Solder Temperature	260 °C, 10 sec.
Laser Continuous Forward Current, Heat Sunked	15 mA
Laser Reverse Breakdown Voltage ( $I_R=10 \mu A$ )	5 V @ 10 $\mu A$

### ELECTRO-OPTICAL CHARACTERISTICS ( $T_A=25^\circ C$ unless otherwise stated)

VCSEL Parameters	Test Condition	Symbol	Min.	Typ.	Max.	Units	Notes
Peak Operating Current	Adjustable to establish operating power	$I_{peak}$		9	20	mA	1
Optical Power Output	$I_F=9mA$	$P_o$		2.4		mW	1
Threshold Current		$I_{TH}$	1	3	5	mA	
Threshold Current Temperature Variation	$T_A = 0^\circ C$ to $70^\circ C$	$\Delta I_{TH}$	-1.5		1.5	mA	2
Slope Efficiency		$\eta$	0.225	0.4	0.6	mW/mA	3
Slope Efficiency Temperature variation	$T_A = 0^\circ C$ to $70^\circ C$	$\Delta\eta/\Delta T$		-6000		PPM/ $^\circ C$	
Peak Wavelength	$I_F=9 mA$	$\lambda_p$	830	850	860	nm	
$\lambda_p$ Temperature Variation	$I_F=9 mA$	$\Delta\lambda_p/\Delta T$		0.06		nm/ $^\circ C$	
Spectral Bandwidth, RMS	$I_F=9 mA$	$\Delta\lambda$			0.85	nm	
Laser Forward Voltage	$I_F=9 mA$	$V_F$		1.8	2.2	V	
Laser Reverse Voltage	$I_R=10 \mu A$	$BVR_{LD}$		-10		V	
Rise and Fall Times	Prebias Above Threshold, 20%-80%	$t_r$ $t_f$			130 150	ps	4
Relative Intensity Noise	1 GHz BW, $I_F=9 mA$	RIN		-130	-122	dB/Hz	
Series Resistance	$I_F=9 mA$	$R_S$	18	25	40	Ohms	
Series Resistance Temperature Coefficient	$I_F=9 mA$ , $0^\circ C$ to $70^\circ C$	$dR_S/dT$		-3000		PPM/ $^\circ C$	
Beam Divergence		$\theta$	15		30	Degrees	5

#### Notes:

1. Operating power is set by the peak operating current  $I_{PEAK}=I_{BIAS}+I_{MODULATION}$ .
2. Operation at temperatures outside the specified range may result in the threshold current exceeding the maximums defined in the electro-optical characteristics table.
3. Slope efficiency is defined as  $\Delta P_o/\Delta I_F$ .
4. Rise and fall times are sensitive to drive electronics.

Beam divergence is defined as the total included angle between the  $1/e^2$  intensity points.

# Fiber Optic Components

## High Speed VCSEL 2.5Gbps VCSEL

HFE4090-321

### NOTICE

Stresses greater than those listed under “Absolute Maximum Ratings” may cause permanent damage to the device. This is a stress rating only and functional operation of the device at these or any other conditions above those indicated in the operations section for extended periods of time may affect reliability.

### TYPICAL PERFORMANCE CURVES

www.DataSheet4U.com

**Emitted Power vs. Current:** Power varies approximately linearly with current above threshold.

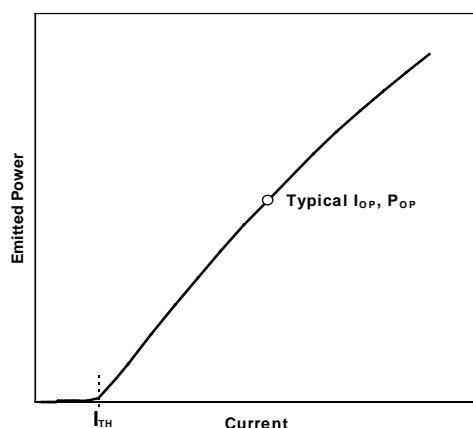

**Emission Intensity vs. Wavelength:** Typical 10 mA spectrum comprises multiple lines corresponding to multiple transverse modes.

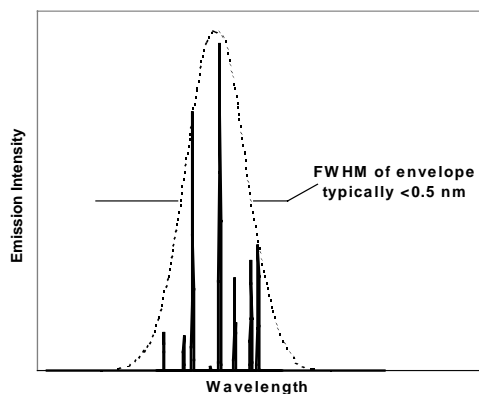

**Threshold Current vs. Temperature:** Threshold current varies parabolically with temperature; thus it can be nearly constant for a limited temperature range.

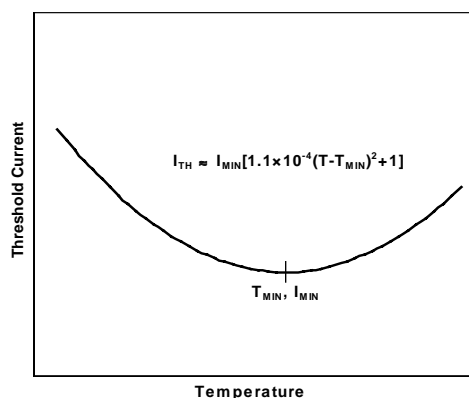

### NOTICE

The inherent design of this component causes it to be sensitive to electrostatic discharge (ESD). To prevent ESD-induced damage and/or degradation to equipment, take normal ESD precautions when handling this product.



The VCSEL is a class IIIb laser and should be treated as a potential eye hazard. Due to the size of the component, the applicable warning logotype, aperture label, and certification/identification label cannot be placed on the component itself. These labels can be found on the individual envelope in which the VCSEL unit is packaged, or attached to the shipping package.

# Fiber Optic LAN Components

## High Speed VCSEL 2.5Gbps VCSEL

HFE4090-321

### ORDER GUIDE

Catalog Listing	Description
HFE4090-321	Unattenuated VCSEL TO-46 component

### MOUNTING DIMENSIONS (for reference only): in./(mm)

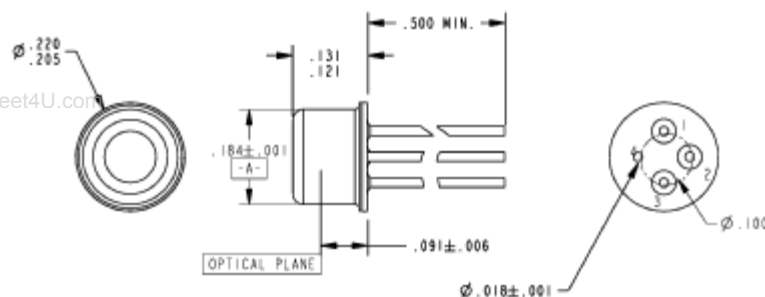

#### NOTES:

- VCSEL BEAM CENTERING  $\pm \phi .006$  A

### PINOUT

HFE4090-321	
Number	Function
1	Cathode
2	Anode
3	Cathode
4	Case

### SALES AND SERVICE

Honeywell Sensing and Control serves its customers through a worldwide network of sales offices and distributors. For application assistance, current specifications, pricing or name of the nearest Authorized Distributor, contact a nearby sales office or call:

### TELEPHONE

1-800-367-6786 (USA)  
 1-800-737-3360 (Canada)  
 +49 (0) 89 35813310 (Germany)  
 +65-580-3312 (Singapore)  
 +44 (0) 118 981 9511 (UK)

### FAX

1-972-470-4326 (Customer Response Center)  
 1-972-470-4549 (Fax on demand)  
 +49 (0) 89 3599971 (Germany)  
 +65 445 3033 (Singapore)  
 +44 (0) 118 981 7513 (UK)

### INTERNET

<http://www.honeywell.com/sensing/VCSEL>  
[info.sc@honeywell.com](mailto:info.sc@honeywell.com)

### WARRANTY/REMEDY

Honeywell warrants goods of its manufacture as being free of defective materials and faulty workmanship. Commencing with the date of shipment, Honeywell's warranty runs for 18 months. If warranted goods are returned to Honeywell during that period of coverage, Honeywell will repair or replace without charge those items it finds defective. The foregoing is Buyer's sole remedy and is **in lieu of all other warranties, expressed or implied, including those of merchantability and fitness for a particular purpose.**

While we provide application assistance, personally and through our literature, it is up to the customer to determine the suitability of the product in the application.

Specifications may change at any time without notice. The information we supply is believed to be accurate and reliable as of this printing. However, we assume no responsibility for its use.

7/6/01

**Honeywell**

Honeywell Inc.  
 11 West Spring Street  
 Freeport, Illinois 61032



Honeywell Inc.  
 Optoelectronics Facility  
 830 East Arapaho Road  
 Richardson, Texas 75081

**Honeywell Control Systems Ltd.**  
 Zodiac House  
 Calleva Park  
 Aldermaston, Berkshire  
 RG7 8HW England

*Helping You Control Your World*

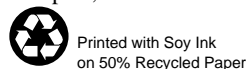

006694-1-EN IL50 GLO 797 Printed in USA

[www.DataSheet4U.com](http://www.DataSheet4U.com)

## Fiber Optic LAN Components High Speed VCSEL 2.5Gbps

# HFE4090-341

### FEATURES

- Designed for drive currents between 3 and 12 mA average
- Optimized for low dependence of electrical properties over temperature
- High speed  $\geq 1$  GHz

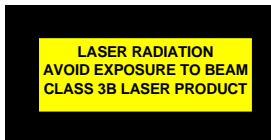

The HFE4090-341 is a high-performance 850 nm VCSEL (Vertical Cavity Surface-Emitting Laser) packaged for high-speed data communications.

The HFE4090-341 is a high radiance VCSEL designed to convert electrical current into optical power that can be used in fiber optic communications and other applications. As the current varies above threshold, the light intensity increases proportionally.

The HFE4090-341 is designed to be used with inexpensive silicon or gallium arsenide detectors, but excellent performance can also be achieved with some indium gallium arsenide detectors.

The low drive current requirement makes direct drive from PECL (Positive Emitter Coupled Logic) or EML (Emitter Coupled Logic) gates possible and eases driver design.

The HFE4090-341 is designed to interface with 50/125 and 62.5/125  $\mu\text{m}$  multimode fiber. It produces circularly symmetric, non-astigmatic, narrow divergence beams that, with appropriate lensing, fiber couple all of the emitter power.

### ABSOLUTE MAXIMUM RATINGS

Parameter	Rating
Storage Temperature	-40 to +100 °C
Operating Temperature	0 to +70 °C
Lead Solder Temperature	260 °C, 10 sec.
Laser Continuous Forward Current, Heat Sunked	12 mA
Laser Reverse Breakdown Voltage ( $I_R=10 \mu A$ )	5 V @ 10 $\mu A$

### ELECTRO-OPTICAL CHARACTERISTICS ( $T_A=25^\circ C$ unless otherwise stated)

VCSEL Parameters	Test Condition	Symbol	Min.	Typ.	Max.	Units	Notes
Peak Operating Current	Adjustable to establish operating power	$I_{peak}$		10	15	mA	1
Optical Power Output	$I_F=7mA$	$P_o$		2.0		mW	1
Threshold Current		$I_{TH}$	1	2.0	3	mA	
Threshold Current Temperature Variation	$T_A = 0^\circ C$ to $70^\circ C$	$\Delta I_{TH}$	-1.5		1.5	mA	2
Slope Efficiency		$\eta$	0.225	0.4	0.6	mW/mA	3
Slope Efficiency Temperature variation	$T_A = 0^\circ C$ to $70^\circ C$	$\Delta\eta/\Delta T$		-6000		PPM/ $^\circ C$	
Peak Wavelength	$I_F=7 mA$	$\lambda_p$	830	850	860	nm	
$\lambda_p$ Temperature Variation	$I_F=7 mA$	$\Delta\lambda_p/\Delta T$		0.06		nm/ $^\circ C$	
Spectral Bandwidth, RMS	$I_F=7 mA$	$\Delta\lambda$			0.85	nm	
Laser Forward Voltage	$I_F=7 mA$	$V_F$		1.8	2.2	V	
Laser Reverse Voltage	$I_R=10 \mu A$	$BVR_{LD}$		-10		V	
Rise and Fall Times	Prebias Above Threshold, 20%-80%	$t_r$ $t_f$			130 150	ps	4
Relative Intensity Noise	1 GHz BW, $I_F=7 mA$	RIN		-130	-122	dB/Hz	
Series Resistance	$I_F=7 mA$	$R_S$	22	35	55	Ohms	
Series Resistance Temperature Coefficient	$I_F=7 mA$ , $0^\circ C$ to $70^\circ C$	$dR_S/dT$		-3000		PPM/ $^\circ C$	
Beam Divergence		$\theta$	15		30	Degrees	5

#### Notes:

1. Operating power is set by the peak operating current  $I_{PEAK}=I_{BIAS}+I_{MODULATION}$ .
2. Operation at temperatures outside the specified range may result in the threshold current exceeding the maximums defined in the electro-optical characteristics table.
3. Slope efficiency is defined as  $\Delta P_o/\Delta I_F$ .
4. Rise and fall times are sensitive to drive electronics.
5. Beam divergence is defined as the total included angle between the  $1/e^2$  intensity points.

# Fiber Optic Components

## High Speed VCSEL 2.5Gbps VCSEL

HFE4090-341

### NOTICE

Stresses greater than those listed under “Absolute Maximum Ratings” may cause permanent damage to the device. This is a stress rating only and functional operation of the device at these or any other conditions above those indicated in the operations section for extended periods of time may affect reliability.

### TYPICAL PERFORMANCE CURVES

www.DataSheet4U.com

**Emitted Power vs. Current:** Power varies approximately linearly with current above threshold.

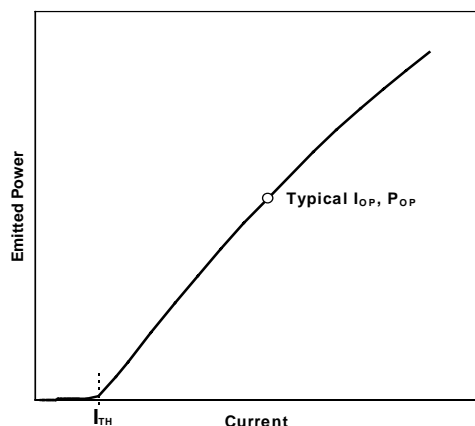

**Emission Intensity vs. Wavelength:** Typical 10 mA spectrum comprises multiple lines corresponding to multiple transverse modes.

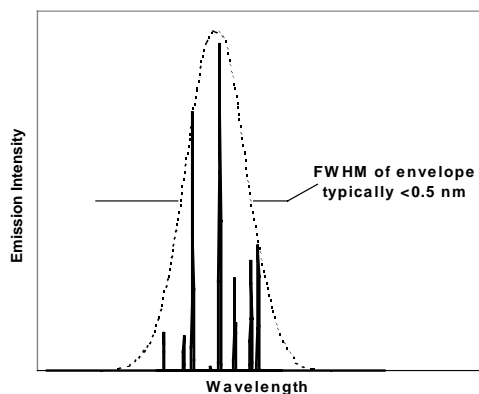

**Threshold Current vs. Temperature:** Threshold current varies parabolically with temperature; thus it can be nearly constant for a limited temperature range.

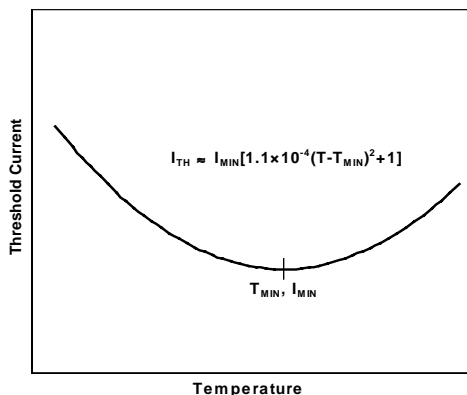

### NOTICE

The inherent design of this component causes it to be sensitive to electrostatic discharge (ESD). To prevent ESD-induced damage and/or degradation to equipment, take normal ESD precautions when handling this product.



The VCSEL is a class IIIb laser and should be treated as a potential eye hazard. Due to the size of the component, the applicable warning logotype, aperture label, and certification/identification label cannot be placed on the component itself. These labels can be found on the individual envelope in which the VCSEL unit is packaged, or attached to the shipping package.

# Fiber Optic LAN Components

## High Speed VCSEL 2.5Gbps VCSEL

HFE4090-341

### ORDER GUIDE

Catalog Listing	Description
HFE4090-341	Unattenuated VCSEL TO-46 component

### MOUNTING DIMENSIONS (for reference only): in./(mm)

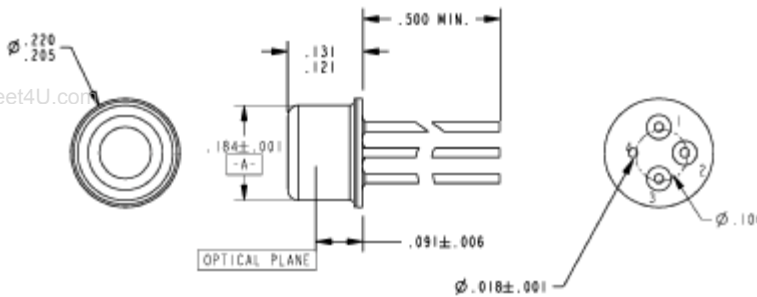

NOTES:  
1. VCSEL BEAM CENTERING  $\pm \phi .006$  A

### PINOUT

HFE4090-341	
Number	Function
1	Cathode
2	Anode
3	Cathode
4	Case

### WARRANTY/REMEDY

Honeywell warrants goods of its manufacture as being free of defective materials and faulty workmanship. Commencing with the date of shipment, Honeywell's warranty runs for 18 months. If warranted goods are returned to Honeywell during that period of coverage, Honeywell will repair or replace without charge those items it finds defective. The foregoing is Buyer's sole remedy and is **in lieu of all other warranties, expressed or implied, including those of merchantability and fitness for a particular purpose.**

While we provide application assistance, personally and through our literature, it is up to the customer to determine the suitability of the product in the application.

Specifications may change at any time without notice. The information we supply is believed to be accurate and reliable as of this printing. However, we assume no responsibility for its use.

01/29/02

**Honeywell**

Honeywell Inc.  
11 West Spring Street  
Freeport, Illinois 61032



Honeywell Inc.  
Optoelectronics Facility  
830 East Arapaho Road  
Richardson, Texas 75081

**Honeywell Control Systems Ltd.**  
Zodiac House  
Calleva Park  
Aldermaston, Berkshire  
RG7 8HW England

*Helping You Control Your World*

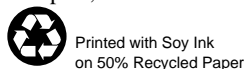

006694-1-EN IL50 GLO 797 Printed in USA

[www.DataSheet4U.com](http://www.DataSheet4U.com)

### SALES AND SERVICE

Honeywell Sensing and Control serves its customers through a worldwide network of sales offices and distributors. For application assistance, current specifications, pricing or name of the nearest Authorized Distributor, contact a nearby sales office or call:

### TELEPHONE

1-800-367-6786 (USA)  
1-800-737-3360 (Canada)  
+49 (0) 89 35813310 (Germany)  
+65-580-3312 (Singapore)  
+44 (0) 118 981 9511 (UK)

### FAX

1-972-470-4326 (Customer Response Center)  
1-972-470-4549 (Fax on demand)  
+49 (0) 89 3599971 (Germany)  
+65 445 3033 (Singapore)  
+44 (0) 118 981 7513 (UK)

### INTERNET

<http://www.honeywell.com/VCSEL>  
VCSEL@honeywell.com



## Fiber Optic LAN Components High Speed VCSEL 2.5Gbps

# HFE409x-341

### FEATURES

- Designed for drive currents between 3 and 12 mA
- Optimized for low dependence of electrical properties over temperature
- High speed  $\geq 1$  GHz
- Two different laser/photodiode polarities
- Attenuating coating
- Packaged with a photodetector

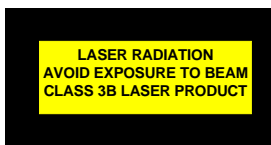

The HFE409x-341 is a high-performance 850 nm VCSEL (Vertical Cavity Surface-Emitting Laser) packaged for high-speed data communications. This product combines all the performance advantages of the VCSEL with a custom designed power monitor diode. The power monitor diode can be used with appropriate feedback control circuitry to set a maximum power level for each VCSEL. In addition, built-in power attenuation reduces the effective slope efficiency. These combined features simplify design for high data rate communication and eye safety.

The HFE409x-341 is a high radiance VCSEL designed to convert electrical current into optical power that can be used in fiber optic communications and other applications. As the current varies above threshold, the light intensity increases proportionally.

The HFE409x-341 is designed to be used with inexpensive silicon or gallium arsenide detectors, but excellent performance can also be achieved with some indium gallium arsenide detectors.

The low drive current requirement makes direct drive from PECL (Positive Emitter Coupled Logic) or EML (Emitter Coupled Logic) gates possible and eases driver design.

The HFE409x-341 is designed to interface with 50/125 and 62.5/125  $\mu\text{m}$  multimode fiber. They product circularly symmetric, non-astigmatic, narrow divergence beams that, with appropriate lensing, fiber couple all of the emmitter power.

# Fiber Optic LAN Components

## High Speed VCSEL 2.5Gbps

HFE409x-341

### ABSOLUTE MAXIMUM RATINGS

Parameter	Rating
Storage Temperature	-40 to +100°C
Operating Temperature	0 to +70°C
Lead Solder Temperature	260°C, 10 sec.
Laser Diode Reverse Voltage ( $I_R=10 \mu A$ )	5 V
Laser Continuous Forward Current, Heat-Sinked	12 mA
PIN Photodiode Forward Current	10 mA

### NOTICE

Stresses greater than those listed under “Absolute Maximum Ratings” may cause permanent damage to the device. This is a stress rating only and functional operation of the device at these or any other conditions above those indicated in the operations section for extended periods of time may affect reliability.

### ELECTRO-OPTICAL CHARACTERISTICS ( $T_A=25^\circ C$ unless otherwise stated)

VCSEL Parameters	Test Condition	Symbol	Min.	Typ.	Max.	Units	Notes
Peak Operating Current	Adjustable to establish operating power	$I_{peak}$		10	15	mA	1
Optical Power Output	$I_F=7mA$	$P_o$		0.8		mW	1
Threshold Current		$I_{TH}$	1	1.8	2.5	mA	
Threshold Current Temperature Variation	$T_A = 0^\circ C$ to $70^\circ C$	$\Delta I_{TH}$	-1		1	mA	2
Slope Efficiency		$\eta$	0.08	0.14	0.25	mW/mA	3
Slope Efficiency Temperature variation	$T_A = 0^\circ C$ to $70^\circ C$	$\Delta\eta / \Delta T$		-4500		PPM/ $^\circ C$	
Peak Wavelength	$I_F=7 mA$	$\lambda_p$	830	850	860	nm	
$\lambda_p$ Temperature Variation	$I_F=7 mA$	$\Delta\lambda_p/\Delta T$		0.06		nm/ $^\circ C$	
Spectral Bandwidth, RMS	$I_F=7 mA$	$\Delta\lambda$			0.85	nm	
Laser Forward Voltage	$I_F=7 mA$	$V_F$		1.8	2.2	V	
Laser Reverse Voltage	$I_R=10 \mu A$	$BVR_{LD}$		-10		V	
Rise and Fall Times	Prebias Above Threshold, 20%-80%	$t_r$ $t_f$			130 150	ps	4
Relative Intensity Noise	1 GHz BW, $I_F=7 mA$	RIN		-130	-122	dB/Hz	
Series Resistance	$I_F=7 mA$	$R_S$	22	35	50	Ohms	
Series Resistance Temperature Coefficient	$I_F=7 mA$ , $0^\circ C$ to $70^\circ C$	$dR_S/dT$		-3000		PPM/ $^\circ C$	
Beam Divergence		$\theta$	15		30	Degrees	5
Photodiode Parameters	Test Condition	Symbol	Min.	Typ.	Max.	Units	Notes
Monitor Current	$P_o = 0.8mW$	$I_{PD}$		0.35		mA	
Monitor current Temperature Variation	$P_o = 0.8mW$	$\Delta I_{PD}/\Delta T$		0.2		%/ $^\circ C$	
Dark Current	$P_o = 0mW$ , $V_R=3V$	$I_D$			20	nA	
PD Reverse Voltage	$P_o = 0mW$ , $I_R=10 \mu A$	$BVR_{PD}$	30	115		V	6
PD Capacitance	$V_R=0V$ , Freq=1MHz	C		75	100	pF	
	$V_R=3V$ , Freq=1MHz			40	55		

# Fiber Optic Components

## High Speed VCSEL 2.5Gbps VCSEL

HFE409x-341

### Notes:

1. Operating power is set by the peak operating current  $I_{PEAK} = I_{BIAS} + I_{MODULATION}$ .
2. Operation at temperatures outside the specified range may result in the threshold current exceeding the maximums defined in the electro-optical characteristics table.
3. Slope efficiency is defined as  $\Delta P_o / \Delta I_f$  at a total power output of 0.8 mW. Slope efficiency is intentionally lowered to the values shown by optical attenuation.
4. Rise and fall times are sensitive to drive electronics
5. Beam divergence is defined as the total included angle between the  $1/e^2$  intensity points. Beam divergence

varies between 15deg and 30deg depending upon operating conditions. 30deg is expected to be worst case divergence. It is recommended that the optics be design for an NA of 0.3.

6. To safeguard the VCSEL from current spike damage, short the VCSEL anode and cathode to each other during photodiode BVR verification testing. Additionally to safeguard the PIN photodiode, limit the photodiode reverse voltage in accordance with the absolute maximum rating.

### TYPICAL PERFORMANCE CURVES

**Emitted Power vs. Current:** Power varies approximately linearly with current above threshold.

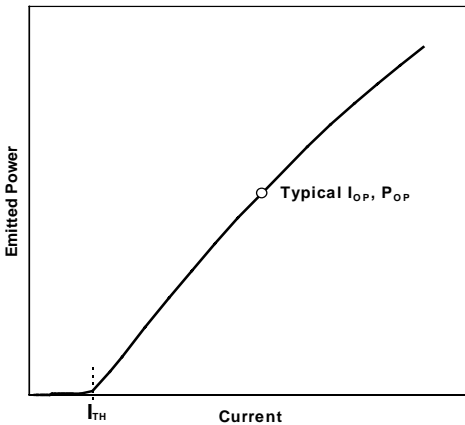

**Emission Intensity vs. Wavelength:** Typical 10 mA spectrum comprises multiple lines corresponding to multiple transverse modes.

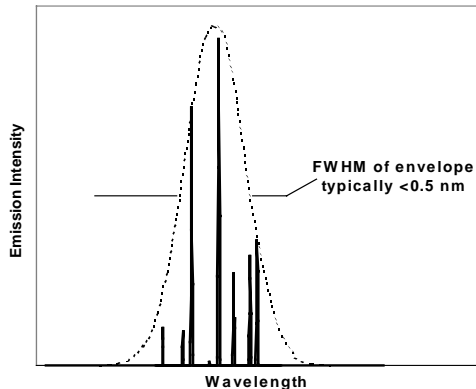

**Threshold Current vs. Temperature:** Threshold current varies parabolically with temperature; thus it can be nearly constant for a limited temperature range.

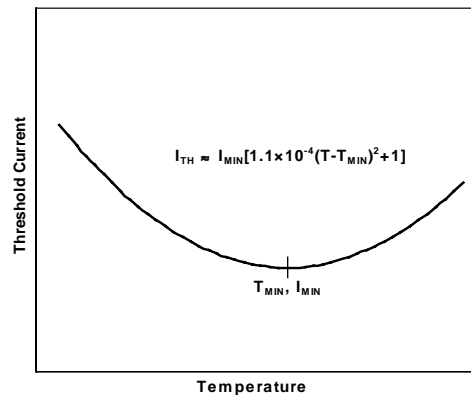

### NOTICE

The inherent design of this component causes it to be sensitive to electrostatic discharge (ESD). To prevent ESD-induced damage and/or degradation to equipment, take normal ESD precautions when handling this product.

### DANGER

The VCSEL is a class IIIb laser and should be treated as a potential eye hazard. Due to the size of the component, the applicable warning logotype, aperture label, and certification/identification label cannot be placed on the component itself. These labels can be found on the individual envelope in which the VCSEL unit is packaged, or attached to the shipping package.

# Fiber Optic LAN Components

## High Speed VCSEL 2.5Gbps VCSEL

HFE409x-341

### ORDER GUIDE

Catalog Listing	Description
HFE4091-341	Attenuated VCSEL with Back Monitor Photodiode - VCSEL Cathode Common
HFE4092-341	Attenuated VCSEL with Back Monitor Photodiode - VCSEL Anode Common

### TELEPHONE

1-800-367-6786 (USA)  
 1-800-737-3360 (Canada)  
 +49 (0) 89 35813310 (Germany)  
 +65-580-3312 (Singapore)  
 +44 (0) 118 981 9511 (UK)

### MOUNTING DIMENSIONS (for reference only): in./(mm)

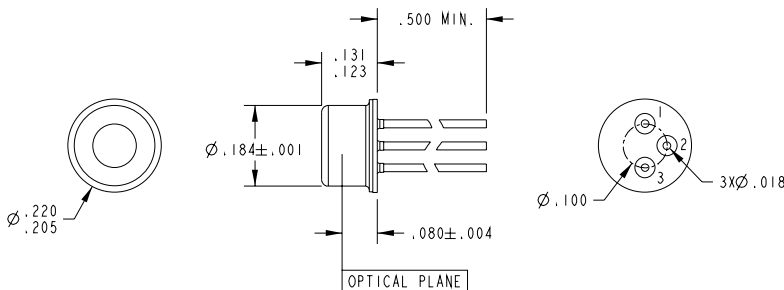

PIN #	HFE4091-341	HFE4092-341
1	VCSEL ANODE	VCSEL CATHODE
2	VCSEL CATHODE/PD ANODE	VCSEL ANODE/PD CATHODE
3	PD CATHODE	PD ANODE

### FAX

1-972-470-4326 (Customer Response Center)  
 1-972-470-4549 (Fax on demand)  
 +49 (0) 89 3599971 (Germany)  
 +65 445 3033 (Singapore)  
 +44 (0) 118 981 7513 (UK)

### INTERNET

<http://www.honeywell.com/VCSEL>  
 VCSEL@honeywell.com

### WARRANTY/REMEDY

Honeywell warrants goods of its manufacture as being free of defective materials and faulty workmanship. Commencing with the date of shipment, Honeywell's warranty runs for 18 months. If warranted goods are returned to Honeywell during that period of coverage, Honeywell will repair or replace without charge those items it finds defective. The foregoing is Buyer's sole remedy and is **in lieu of all other warranties, expressed or implied, including those of merchantability and fitness for a particular purpose.**

While we provide application assistance, personally and through our literature, it is up to the customer to determine the suitability of the product in the application.

Specifications may change at any time without notice. The information we supply is believed to be accurate and reliable as of this printing. However, we assume no responsibility for its use.

### SALES AND SERVICE

Honeywell Sensing and Control serves its customers through a worldwide network of sales offices and distributors. For application assistance, current specifications, pricing or name of the nearest Authorized Distributor, contact a nearby sales office or call:

08/09/02

**Honeywell**

Honeywell Inc.  
 11 West Spring Street  
 Freeport, Illinois 61032



Honeywell Inc.  
 Optoelectronics Facility  
 830 East Arapaho Road  
 Richardson, Texas 75081

**Honeywell Control Systems Ltd.**  
 Zodiac House  
 Calleva Park  
 Aldermaston, Berkshire  
 RG7 8HW England

*Helping You Control Your World*

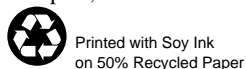

006694-1-EN IL50 GLO 797 Printed in USA

[www.DataSheet4U.com](http://www.DataSheet4U.com)

### High Speed VCSEL 2.5Gbps

#### FEATURES

- Designed for drive currents between 3 and 12 mA
- Optimized for low dependence of electrical properties over temperature
- High speed  $\geq 1$  GHz
- Two different laser/photodiode polarities
- Attenuating coating also available
- Packaged with a photodetector



The HFE409x-342 is a high-performance 850 nm VCSEL (Vertical Cavity Surface-Emitting Laser) packaged for high-speed data communications. This product combines all the performance advantages of the VCSEL with a custom designed power monitor diode, and is designed for ease of use by the module designer and manufacturer. The power monitor diode can be used with appropriate feedback control circuitry to set a maximum power level for each VCSEL, simplifying design for high data rate communication and eye safety.

The HFE409x-342 is a high radiance VCSEL designed to convert electrical current into optical power that can be used in fiber optic communications and other applications. As the current varies above threshold, the light intensity increases proportionally.

The HFE409x-342 is designed to be used with inexpensive silicon or gallium arsenide detectors, but excellent performance can also be achieved with some indium gallium arsenide detectors.

The low drive current requirement makes direct drive from PECL (Positive Emitter Coupled Logic) or EML (Emitter Coupled Logic) gates possible and eases driver design.

The HFE409x-342 is designed to interface with 50/125 and 62.5/125  $\mu\text{m}$  multimode fiber. It produces a circularly symmetric, non-astigmatic, narrow divergence beams that, with appropriate lensing, fiber couple all of the emitter power.

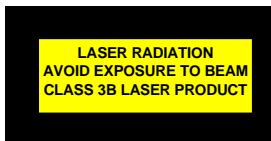

# Fiber Optic LAN Components

## High Speed VCSEL 2.5Gbps

HFE409x-342

### ABSOLUTE MAXIMUM RATINGS

Parameter	Rating
Storage Temperature	-40 to +100°C
Operating Temperature	0 to +70°C
Lead Solder Temperature	260°C, 10 sec.
Laser Diode Reverse Voltage ( $I_R=10 \mu\text{A}$ )	5 V
Laser Continuous Forward Current, Heat-Sinked	12 mA
PIN Photodiode Forward Current	10 mA

### NOTICE

Stresses greater than those listed under “Absolute Maximum Ratings” may cause permanent damage to the device. This is a stress rating only and functional operation of the device at these or any other conditions above those indicated in the operations section for extended periods of time may affect reliability.

### ELECTRO-OPTICAL CHARACTERISTICS ( $T_A=25^\circ\text{C}$ unless otherwise stated)

VCSEL Parameters	Test Condition	Symbol	Min.	Typ.	Max.	Units	Notes
Peak Operating Current	Adjustable to establish operating power	$I_{\text{peak}}$		10	15	mA	1
Optical Power Output	$I_F=7\text{mA}$	$P_o$		2		mW	1
Threshold Current		$I_{\text{TH}}$	1	1.8	2.5	mA	
Threshold Current Temperature Variation	$T_A = 0^\circ\text{C}$ to $70^\circ\text{C}$	$\Delta I_{\text{TH}}$	-1		1	mA	2
Slope Efficiency		$\eta$	0.225	0.4	0.6	mW/mA	3
Slope Efficiency Temperature variation	$T_A = 0^\circ\text{C}$ to $70^\circ\text{C}$	$\Delta\eta / \Delta T$		-4500		PPM/ $^\circ\text{C}$	
Peak Wavelength	$I_F=7 \text{ mA}$	$\lambda_p$	830	850	860	nm	
$\lambda_p$ Temperature Variation	$I_F=7 \text{ mA}$	$\Delta\lambda_p/\Delta T$		0.06		nm/ $^\circ\text{C}$	
Spectral Bandwidth, RMS	$I_F=7 \text{ mA}$	$\Delta\lambda$			0.85	nm	
Laser Forward Voltage	$I_F=7 \text{ mA}$	$V_F$		1.8	2.2	V	
Laser Reverse Voltage	$I_R=10 \mu\text{A}$	$BVR_{\text{LD}}$		-10		V	
Rise and Fall Times	Prebias Above Threshold, 20%-80%	$t_r$ $t_f$			130 150	ps	4
Relative Intensity Noise	1 GHz BW, $I_F=7 \text{ mA}$	RIN		-130	-122	dB/Hz	
Series Resistance	$I_F=7 \text{ mA}$	$R_S$	22	35	50	Ohms	
Series Resistance Temperature Coefficient	$I_F=7 \text{ mA}$ , $0^\circ\text{C}$ to $70^\circ\text{C}$	$dR_S/dT$		-3000		PPM/ $^\circ\text{C}$	
Beam Divergence		$\theta$	15		30	Degrees	5
Photodiode Parameters	Test Condition	Symbol	Min.	Typ.	Max.	Units	Notes
Monitor Current	$P_o = 2.0\text{mW}$	$I_{\text{PD}}$		0.075		mA	
Monitor current Temperature Variation	$P_o = 2.0\text{mW}$	$\Delta I_{\text{PD}}/\Delta T$		0.2		%/ $^\circ\text{C}$	
Dark Current	$P_o = 0\text{mW}$ , $V_R=3\text{V}$	$I_D$			20	nA	
PD Reverse Voltage	$P_o = 0\text{mW}$ , $I_R=10 \mu\text{A}$	$BVR_{\text{PD}}$	30	115		V	6
PD Capacitance	$V_R=0\text{V}$ , Freq=1MHz	C		75	100	pF	
	$V_R=3\text{V}$ , Freq=1MHz			40	55		

# Fiber Optic Components

## High Speed VCSEL 2.5Gbps VCSEL

HFE409x-342

### Notes:

1. Operating power is set by the peak operating current  $I_{PEAK} = I_{BIAS} + I_{MODULATION}$ .
2. Operation at temperatures outside the specified range may result in the threshold current exceeding the maximums defined in the electro-optical characteristics table.
3. Slope efficiency is defined as  $\Delta P_o / \Delta I_F$  at a total power output of 2.0 mW.
4. Rise and fall times are sensitive to drive electronics
5. Beam divergence is defined as the total included angle between the  $1/e^2$  intensity points. Beam divergence

varies between 15deg and 30deg depending upon operating conditions. 30deg is expected to be worst case divergence. It is recommended that the optics be design for an NA of 0.3

6. To safeguard the VCSEL from current spike damage, short the VCSEL anode and cathode to each other during photodiode BVR verification testing. Additionally to safeguard the PIN photodiode, limit the photodiode reverse voltage in accordance with the absolute maximum rating.

### TYPICAL PERFORMANCE CURVES

**Emitted Power vs. Current:** Power varies approximately linearly with current above threshold.

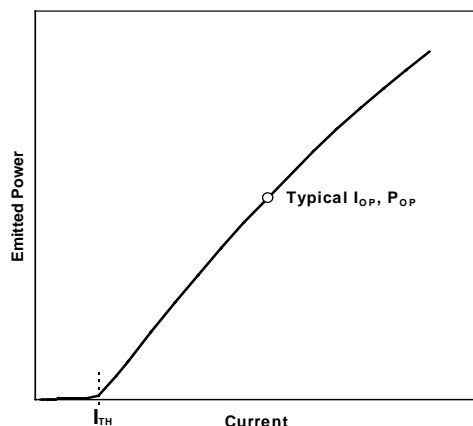

**Emission Intensity vs. Wavelength:** Typical 10 mA spectrum comprises multiple lines corresponding to multiple transverse modes.

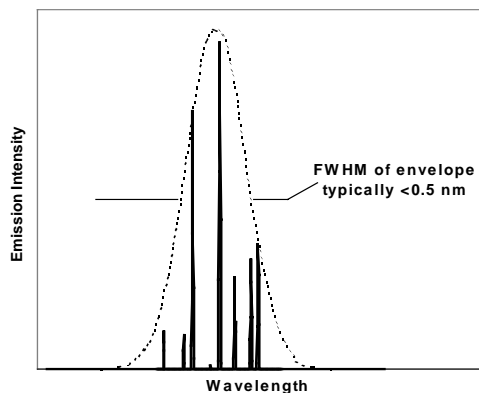

**Threshold Current vs. Temperature:** Threshold current varies parabolically with temperature; thus it can be nearly constant for a limited temperature range.

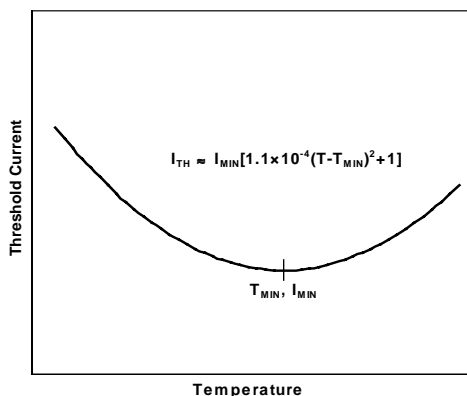

### NOTICE

The inherent design of this component causes it to be sensitive to electrostatic discharge (ESD). To prevent ESD-induced damage and/or degradation to equipment, take normal ESD precautions when handling this product.

### DANGER

The VCSEL is a class IIIb laser and should be treated as a potential eye hazard. Due to the size of the component, the applicable warning logotype, aperture label, and certification/identification label cannot be placed on the component itself. These labels can be found on the individual envelope in which the VCSEL unit is packaged, or attached to the shipping package.

# Fiber Optic LAN Components

## High Speed VCSEL 2.5Gbps VCSEL

# HFE409x-342

### ORDER GUIDE

Catalog Listing	Description
HFE4093-342	Unattenuated VCSEL with Back Monitor Photodiode - VCSEL Anode Common
HFE4094-342	Unattenuated VCSEL with Back Monitor Photodiode - VCSEL Cathode Common

### TELEPHONE

1-800-367-6786 (USA)  
 1-800-737-3360 (Canada)  
 +49 (0) 89 35813310 (Germany)  
 +65-580-3312 (Singapore)  
 +44 (0) 118 981 9511 (UK)

### MOUNTING DIMENSIONS (for reference only): in./(mm)

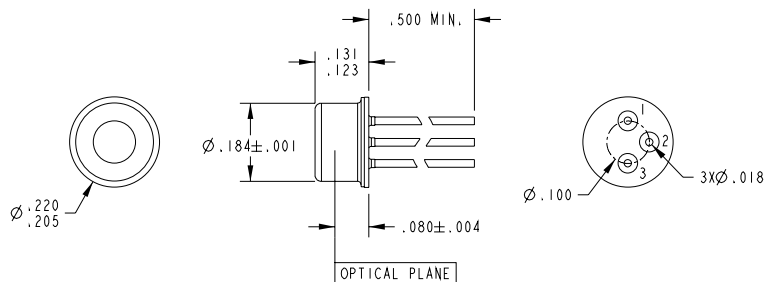

PIN #	HFE4091-341	HFE4092-341
1	VCSEL ANODE	VCSEL CATHODE
2	VCSEL CATHODE/PD ANODE	VCSEL ANODE/PD CATHODE
3	PD CATHODE	PD ANODE

### FAX

1-972-470-4326 (Customer Response Center)  
 1-972-470-4549 (Fax on demand)  
 +49 (0) 89 3599971 (Germany)  
 +65 445 3033 (Singapore)  
 +44 (0) 118 981 7513 (UK)

### INTERNET

<http://www.honeywell.com/VCSEL>  
[VCSEL@honeywell.com](mailto:VCSEL@honeywell.com)

### WARRANTY/REMEDY

Honeywell warrants goods of its manufacture as being free of defective materials and faulty workmanship. Commencing with the date of shipment, Honeywell's warranty runs for 18 months. If warranted goods are returned to Honeywell during that period of coverage, Honeywell will repair or replace without charge those items it finds defective. The foregoing is Buyer's sole remedy and is **in lieu of all other warranties, expressed or implied, including those of merchantability and fitness for a particular purpose.**

While we provide application assistance, personally and through our literature, it is up to the customer to determine the suitability of the product in the application.

Specifications may change at any time without notice. The information we supply is believed to be accurate and reliable as of this printing. However, we assume no responsibility for its use.

### SALES AND SERVICE

Honeywell Sensing and Control serves its customers through a worldwide network of sales offices and distributors. For application assistance, current specifications, pricing or name of the nearest Authorized Distributor, contact a nearby sales office or call:

08/09/02

# Honeywell

Honeywell Inc.  
 11 West Spring Street  
 Freeport, Illinois 61032



Honeywell Inc.  
 Optoelectronics Facility  
 830 East Arapaho Road  
 Richardson, Texas 75081

**Honeywell Control Systems Ltd.**  
 Zodiac House  
 Calleva Park  
 Aldermaston, Berkshire  
 RG7 8HW England

*Helping You Control Your World*

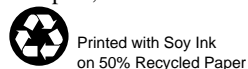

006694-1-EN IL50 GLO 797 Printed in USA

[www.DataSheet4U.com](http://www.DataSheet4U.com)



# Fiber Optic Components

## GaAs 850 nm VCSEL

HFE4080-321

### ABSOLUTE MAXIMUM RATINGS

Parameter	Rating
Storage Temperature	-40 to +100 °C
Operating Temperature	0 to +70 °C
Lead Solder Temperature	260 °C, 10 sec.
Laser Continuous Forward Current, Heat Sunked	15 mA
Laser Reverse Breakdown Voltage ( $I_R=10 \mu A$ )	5 V @ 10 $\mu A$

### ELECTRO-OPTICAL CHARACTERISTICS ( $T_A=25^\circ C$ unless otherwise stated)

VCSEL Parameters	Test Condition	Symbol	Min.	Typ.	Max.	Units	Notes
Peak Operating Current	Adjustable to establish operating power	$I_{peak}$		12	20	mA	1
Optical Power Output	$I_F=12mA$	$P_o$	0.9	1.8	3.6	mW	1
Threshold Current		$I_{TH}$	1.5	3.5	6	mA	
Threshold Current Temperature Variation	$T_A = 0^\circ C$ to $70^\circ C$	$\Delta I_{TH}$	-1.5		1.5	mA	2
Slope Efficiency	$P_o = 1.3mW$	$\eta$	0.1	0.25	0.4	mW/mA	3
Slope Efficiency Temperature variation	$T_A = 0^\circ C$ to $70^\circ C$	$\Delta \eta / \Delta T$		-0.5		%/ $^\circ C$	
Peak Wavelength	$I_F=12mA$	$\lambda_p$	830	850	860	nm	
$\lambda_p$ Temperature Variation	$I_F=12mA$	$\Delta \lambda_p / \Delta T$		0.06		nm/ $^\circ C$	
Spectral Bandwidth, RMS	$I_F=12mA$	$\Delta \lambda$			0.85	nm	
Laser Forward Voltage	$I_F=12 mA$	$V_F$	1.6	1.8	2.2	V	
Laser Reverse Voltage	$I_R=10 \mu A$	$BVR_{LD}$	5	10		V	
Rise and Fall Times	Prebias Above Threshold, 20%-80%	$t_r/t_f$		100	300	ps	4
Relative Intensity Noise	1 GHz BW, $I_F=12mA$	RIN		-128	-122	dB/Hz	
Series Resistance	$I_F=12 mA$	$R_S$	18	25	40	Ohms	
Beam Divergence	$I_F=12 mA$	$\theta$	5	15	20	Degrees	5

#### Notes:

1. Operating power is set by the peak operating current  $I_{PEAK}=I_{BIAS}+I_{MODULATION}$ .
2. Operation at temperatures outside the specified range may result in the threshold current exceeding the maximums defined in the electro-optical characteristics table.
3. Slope efficiency is defined as  $\Delta P_o/\Delta I_F$  at a total power output of 1.3 mW.
4. Rise and fall times are sensitive to drive electronics, 200ps rise and fall times are achievable with Honeywell VCSELs.
5. Beam divergence is defined as the total included angle between the  $1/e^2$  intensity points.

## Fiber Optic LAN Components

## HFE408x-321

### High Speed VCSEL 1.25Gbps

#### FEATURES

- Designed for drive currents between 5 and 15 mA
- Optimized for low dependence of electrical properties over temperature
- High speed  $\geq 1$  GHz
- Two different laser/photodiode polarities
- Attenuating coating
- Packaged with a photodetector



The HFE408x-321 is a high-performance 850 nm VCSEL (Vertical Cavity Surface-Emitting Laser) packaged for high-speed data communications. This product combines all the performance advantages of the VCSEL with a custom designed power monitor diode. The power monitor diode can be used with appropriate feedback control circuitry to set a maximum power level for each VCSEL. In addition, built-in power attenuation reduces the effective slope efficiency. These combined features simplify design for high data rate communication and eye safety.

The HFE408x-321 is a high radiance VCSEL designed to convert electrical current into optical power that can be used in fiber optic communications and other applications. As the current varies above threshold, the light intensity increases proportionally.

The HFE408x-321 is designed to be used with inexpensive silicon or gallium arsenide detectors, but excellent performance can also be achieved with some indium gallium arsenide detectors.

The low drive current requirement makes direct drive from PECL (Positive Emitter Coupled Logic) or EML (Emitter Coupled Logic) gates possible and eases driver design.

The HFE408x-321 is designed to interface with 50/125 and 62.5/125  $\mu\text{m}$  multimode fiber. They product circularly symmetric, non-astigmatic, narrow divergence beams that, with appropriate lensing, fiber couple all of the emitter power.

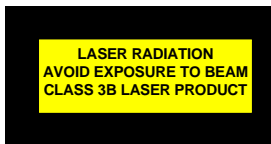

# Fiber Optic LAN Components

## High Speed VCSEL 1.25Gbps

HFE408x-321

### ABSOLUTE MAXIMUM RATINGS

Parameter	Rating
Storage Temperature	-40 to +125°C
Operating Temperature	0 to +70°C
Lead Solder Temperature	260°C, 10 sec.
Continuous Optical Output Power (Any Current)	5 mW
Laser Diode Reverse Voltage ( $I_R=10 \mu A$ )	5 V
Laser Continuous Forward Current, Heat-Sinked	15 mA
PIN Photodiode Forward Current	10 mA

### NOTICE

Stresses greater than those listed under “Absolute Maximum Ratings” may cause permanent damage to the device. This is a stress rating only and functional operation of the device at these or any other conditions above those indicated in the operations section for extended periods of time may affect reliability.

www.DataSheet4U.com

### ELECTRO-OPTICAL CHARACTERISTICS ( $T_A=25^\circ C$ unless otherwise stated)

VCSEL Parameters	Test Condition	Symbol	Min.	Typ.	Max.	Units	Notes
Peak Operating Current	Adjustable to establish operating power	$I_{peak}$		12	20	mA	1
Optical Power Output	$I_F=12mA$	$P_o$	0.3	0.6	1.2	mW	1
Threshold Current		$I_{TH}$	1.5	3.5	6	mA	
Threshold Current Temperature Variation	$T_A = 0^\circ C$ to $70^\circ C$	$\Delta I_{TH}$	-1.5		1.5	mA	2
Slope Efficiency	$P_o = 0.5mW$	$\eta$	0.04	0.1	0.16	mW/mA	3
Slope Efficiency Temperature variation	$T_A = 0^\circ C$ to $70^\circ C$	$\Delta\eta / \Delta T$		-0.5		%/ $^\circ C$	
Peak Wavelength	$I_F=12mA$	$\lambda_p$	830	850	860	nm	
$\lambda_p$ Temperature Variation	$I_F=12mA$	$\Delta\lambda_p / \Delta T$		0.06		nm/ $^\circ C$	
Spectral Bandwidth, RMS	$I_F=12mA$	$\Delta\lambda$			0.85	nm	
Laser Forward Voltage	$I_F=12 mA$	$V_F$	1.6	1.8	2.2	V	
Laser Reverse Voltage	$I_R=10 \mu A$	$BVR_{LD}$	5	10		V	
Rise and Fall Times	Prebias Above Threshold, 20%-80%	$t_r$ $t_f$		150 200	300 300	ps	4
Relative Intensity Noise	1 GHz BW, $I_F=12mA$	RIN		-128	-122	dB/Hz	
Series Resistance	$I_F=12 mA$	$R_S$	18	25	40	Ohms	
Beam Divergence	$I_F=12 mA$	$\theta$	5	15	20	Degrees	5
Photodiode Parameters	Test Condition	Symbol	Min.	Typ.	Max.	Units	Notes
Monitor Current	$P_o = 0.5mW$	$I_{PD}$	0.075		0.250	mA	
Monitor current Temperature Variation	$P_o = 0.5mW$	$\Delta I_{PD} / \Delta T$		0.2		%/ $^\circ C$	
Dark Current	$P_o = 0mW$ , $V_R=3V$	$I_D$			20	nA	
PD Reverse Voltage	$P_o = 0mW$ , $I_R=10 \mu A$	$BVR_{PD}$	30	115		V	6
PD Capacitance	$V_R=0V$ , Freq=1MHz	C		75	100	pF	
	$V_R=3V$ , Freq=1MHz			40	55		

# Fiber Optic Components

## High Speed VCSEL 1.25Gbps

HFE408x-321

### Notes:

1. Operating power is set by the peak operating current  $I_{PEAK} = I_{BIAS} + I_{MODULATION}$ .
2. Operation at temperatures outside the specified range may result in the threshold current exceeding the maximums defined in the electro-optical characteristics table.
3. Slope efficiency is defined as  $\Delta P_o / \Delta I_f$  at a total power output of 0.5 mW. Slope efficiency is intentionally lowered to the values shown by optical attenuation.
4. Rise and fall times are sensitive to drive electronics, 200ps rise and fall times are achievable with Honeywell VCSELs.
5. Beam divergence is defined as the total included angle between the  $1/e^2$  intensity points.
6. To safeguard the VCSEL from current spike damage, short the VCSEL anode and cathode to each other during photodiode BVR verification testing. Additionally to safeguard the PIN photodiode, limit the photodiode reverse voltage in accordance with the absolute maximum rating.

www.DataSheet4U.com

### TYPICAL PERFORMANCE CURVES

**Emitted Power vs. Current:** Power varies approximately linearly with current above threshold.

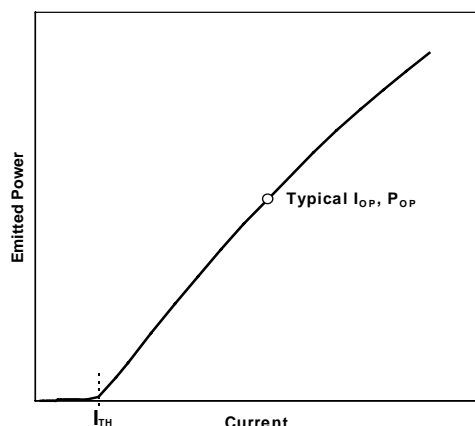

**Emission Intensity vs. Wavelength:** Typical 10 mA spectrum comprises multiple lines corresponding to multiple transverse modes.

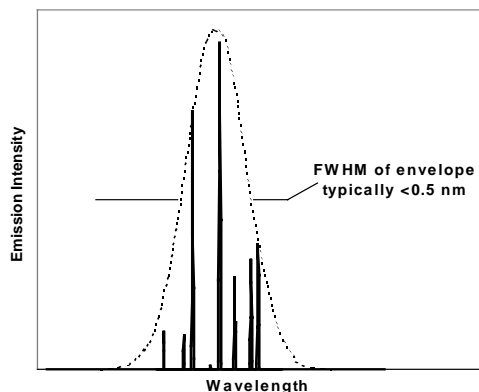

**Threshold Current vs. Temperature:** Threshold current varies parabolically with temperature; thus it can be nearly constant for a limited temperature range.

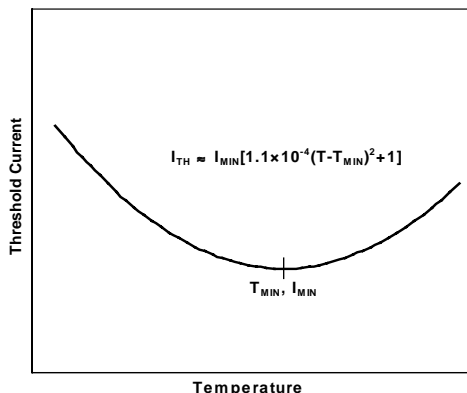

### NOTICE

The inherent design of this component causes it to be sensitive to electrostatic discharge (ESD). To prevent ESD-induced damage and/or degradation to equipment, take normal ESD precautions when handling this product.

### DANGER

The VCSEL is a class IIIb laser and should be treated as a potential eye hazard. Due to the size of the component, the applicable warning logotype, aperture label, and certification/identification label cannot be placed on the component itself. These labels can be found on the individual envelope in which the VCSEL unit is packaged, or attached to the shipping package.

# Fiber Optic LAN Components

## High Speed VCSEL 1.25Gbps VCSEL

HFE408x-321

### ORDER GUIDE

Catalog Listing	Description
HFE4081-321	Attenuated VCSEL with Back Monitor Photodiode - VCSEL Cathode Common
HFE4082-321	Attenuated VCSEL with Back Monitor Photodiode - VCSEL Anode Common

### MOUNTING DIMENSIONS (for reference only): in./(mm)

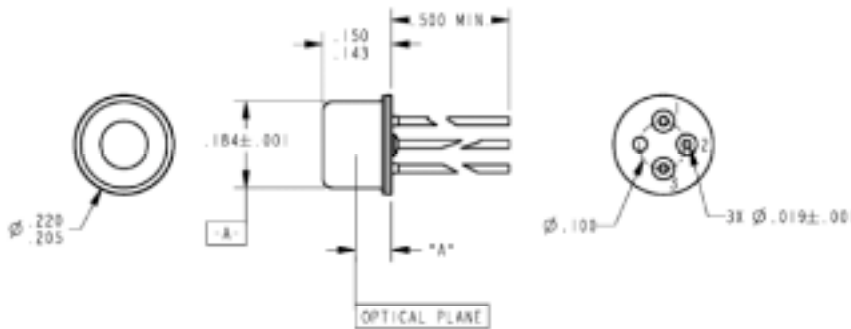

DIMENSION A = 0.078 ± 0.004

### PINOUT

HFE4082-321		HFE4081-321	
Number	Function	Number	Function
1	K <sub>LD</sub>	1	A <sub>LD</sub>
2	K <sub>PD</sub> , A <sub>LD</sub>	2	K <sub>LD</sub> , A <sub>PD</sub>
3	A <sub>PD</sub>	3	K <sub>PD</sub>

### PINOUT DEFINITIONS

A <sub>LD</sub>	VCSEL Anode	A <sub>PD</sub>	Monitor Photodiode Anode
K <sub>LD</sub>	VCSEL Cathode	K <sub>PD</sub>	Monitor Photodiode Cathode

### WARRANTY/REMEDY

Honeywell warrants goods of its manufacture as being free of defective materials and faulty workmanship. Commencing with the date of shipment, Honeywell's warranty runs for 18 months. If warranted goods are returned to Honeywell during that period of coverage, Honeywell will repair or replace without charge those items it finds defective. The foregoing is Buyer's sole remedy and is **in lieu of all other warranties, expressed or implied, including those of merchantability and fitness for a particular purpose.**

02/19/02

**Honeywell**

Honeywell Inc.  
11 West Spring Street  
Freeport, Illinois 61032



Honeywell Inc.  
Optoelectronics Facility  
830 East Arapaho Road  
Richardson, Texas 75081

**Honeywell Control Systems Ltd.**  
Zodiac House  
Calleva Park  
Aldermaston, Berkshire  
RG7 8HW England

*Helping You Control Your World*

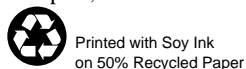

006694-1-EN IL50 GLO 797 Printed in USA

[www.DataSheet4U.com](http://www.DataSheet4U.com)

While we provide application assistance, personally and through our literature, it is up to the customer to determine the suitability of the product in the application.

Specifications may change at any time without notice. The information we supply is believed to be accurate and reliable as of this printing. However, we assume no responsibility for its use.

### SALES AND SERVICE

Honeywell Sensing and Control serves its customers through a worldwide network of sales offices and distributors. For application assistance, current specifications, pricing or name of the nearest Authorized Distributor, contact a nearby sales office or call:

### TELEPHONE

1-800-367-6786 (USA)  
1-800-737-3360 (Canada)  
+49 (0) 89 35813310 (Germany)  
+65-580-3312 (Singapore)  
+44 (0) 118 981 9511 (UK)

### FAX

1-972-470-4326 (Customer Response Center)  
1-972-470-4549 (Fax on demand)  
+49 (0) 89 3599971 (Germany)  
+65 445 3033 (Singapore)  
+44 (0) 118 981 7513 (UK)

### INTERNET

<http://www.honeywell.com/sensing/VCSEL>  
[info.sc@honeywell.com](mailto:info.sc@honeywell.com)

## Fiber Optic LAN Components High Speed VCSEL 1.25Gbps

# HFE408x-322

### FEATURES

- Designed for drive currents between 5 and 15 mA
- Optimized for low dependence of electrical properties over temperature
- High speed  $\geq 1$  GHz
- Two different laser/photodiode polarities
- Attenuating coating also available
- Packaged with a photodetector



The HFE408x-322 is a high-performance 850 nm VCSEL (Vertical Cavity Surface-Emitting Laser) packaged for high-speed data communications. This product combines all the performance advantages of the VCSEL with a custom designed power monitor diode, and is designed for ease of use by the module designer and manufacturer. The power monitor diode can be used with appropriate feedback control circuitry to set a maximum power level for each VCSEL, simplifying design for high data rate communication and eye safety.

The HFE408x-322 is a high radiance VCSEL designed to convert electrical current into optical power that can be used in fiber optic communications and other applications. As the current varies above threshold, the light intensity increases proportionally.

The HFE408x-322 is designed to be used with inexpensive silicon or gallium arsenide detectors, but excellent performance can also be achieved with some indium gallium arsenide detectors.

The low drive current requirement makes direct drive from PECL (Positive Emitter Coupled Logic) or EML (Emitter Coupled Logic) gates possible and eases driver design.

The HFE408x-322 is designed to interface with 50/125 and 62.5/125  $\mu\text{m}$  multimode fiber. They product circularly symmetric, non-astigmatic, narrow divergence beams that, with appropriate lensing, fiber couple all of the emitter power.

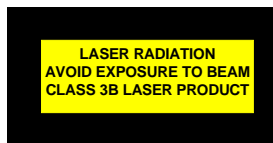

# Fiber Optic LAN Components

## High Speed VCSEL 1.25Gbps

HFE408x-322

### ABSOLUTE MAXIMUM RATINGS

Parameter	Rating
Storage Temperature	-40 to +125°C
Operating Temperature	0 to +70°C
Lead Solder Temperature	260°C, 10 sec.
Continuous Optical Output Power (Any Current)	5 mW
Laser Diode Reverse Voltage ( $I_R=10 \mu A$ )	5 V
Laser Continuous Forward Current, Heat-Sinked	15 mA
PIN Photodiode Forward Current	10 mA

### NOTICE

Stresses greater than those listed under “Absolute Maximum Ratings” may cause permanent damage to the device. This is a stress rating only and functional operation of the device at these or any other conditions above those indicated in the operations section for extended periods of time may affect reliability.

www.DataSheet4U.com

### ELECTRO-OPTICAL CHARACTERISTICS ( $T_A=25^\circ C$ unless otherwise stated)

VCSEL Parameters	Test Condition	Symbol	Min.	Typ.	Max.	Units	Notes
Peak Operating Current	Adjustable to establish operating power	$I_{peak}$		12	20	mA	1
Optical Power Output	$I_F=12mA$	$P_o$	0.9	1.8	3.6	mW	1
Threshold Current		$I_{TH}$	1.5	3.5	6	mA	
Threshold Current Temperature Variation	$T_A = 0^\circ C$ to $70^\circ C$	$\Delta I_{TH}$	-1.5		1.5	mA	2
Slope Efficiency	$P_o=1.3mW$	$\eta$	0.1	0.25	0.4	mW/mA	3
Slope Efficiency Temperature variation	$T_A = 0^\circ C$ to $70^\circ C$	$\Delta\eta / \Delta T$		-0.5		%/ $^\circ C$	
Peak Wavelength	$I_F=12mA$	$\lambda_p$	830	850	860	nm	
$\lambda_p$ Temperature Variation	$I_F=12mA$	$\Delta\lambda_p/\Delta T$		0.06		nm/ $^\circ C$	
Spectral Bandwidth, RMS	$I_F=12mA$	$\Delta\lambda$			0.85	nm	
Laser Forward Voltage	$I_F=12 mA$	$V_F$	1.6	1.8	2.2	V	
Laser Reverse Voltage	$I_R=10 \mu A$	$BVR_{LD}$	5	10		V	
Rise and Fall Times	Prebias Above Threshold, 20%-80%	$t_r$ $t_f$		150 200	300 300	ps	4
Relative Intensity Noise	1 GHz BW, $I_F=12mA$	RIN		-128	-122	dB/Hz	
Series Resistance	$I_F=12 mA$	$R_S$	18	25	40	Ohms	
Beam Divergence	$I_F=12 mA$	$\theta$	5	15	20	Degrees	5
Photodiode Parameters	Test Condition	Symbol	Min.	Typ.	Max.	Units	Notes
Monitor Current	$P_o=1.3mW$	$I_{PD}$	0.015		0.056	mA	
Monitor current Temperature Variation	$P_o=1.3mW$	$\Delta I_{PD}/\Delta T$		0.2		%/ $^\circ C$	
Dark Current	$P_o=0mW, V_R=3V$	$I_D$			20	nA	
PD Reverse Voltage	$P_o=0mW, I_R=10 \mu A$	$BVR_{PD}$	30	115		V	6
PD Capacitance	$V_R=0V, Freq=1MHz$ $V_R=3V, Freq=1MHz$	C		75 40	100 55	pF	

# Fiber Optic Components

## High Speed VCSEL 1.25Gbps

HFE408x-322

### Notes:

1. Operating power is set by the peak operating current  $I_{PEAK} = I_{BIAS} + I_{MODULATION}$ .
2. Operation at temperatures outside the specified range may result in the threshold current exceeding the maximums defined in the electro-optical characteristics table.
3. Slope efficiency is defined as  $\Delta P_o / \Delta I_f$  at a total power output of 1.3 mW.
4. Rise and fall times are sensitive to drive electronics, 200ps rise and fall times are achievable with Honeywell VCSELs.
5. Beam divergence is defined as the total included angle between the  $1/e^2$  intensity points.
6. To safeguard the VCSEL from current spike damage, short the VCSEL anode and cathode to each other during photodiode BVR verification testing. Additionally to safeguard the PIN photodiode, limit the photodiode reverse voltage in accordance with the absolute maximum rating.

### TYPICAL PERFORMANCE CURVES

**Emitted Power vs. Current:** Power varies approximately linearly with current above threshold.

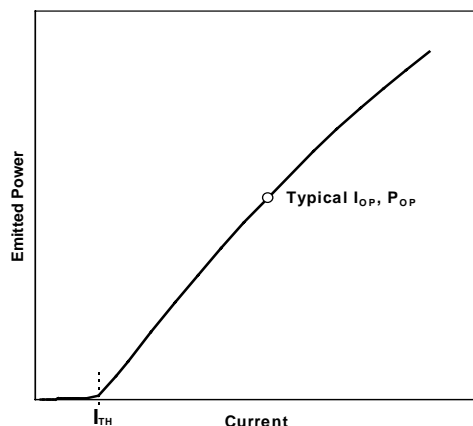

**Emission Intensity vs. Wavelength:** Typical 10 mA spectrum comprises multiple lines corresponding to multiple transverse modes.

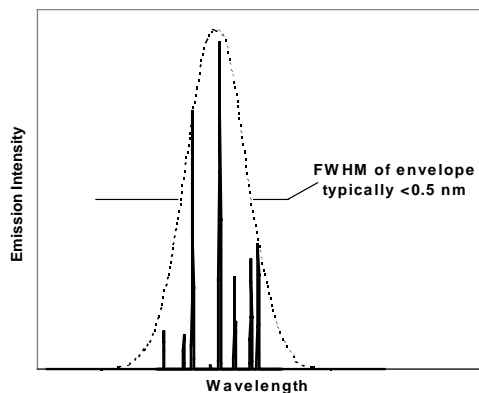

**Threshold Current vs. Temperature:** Threshold current varies parabolically with temperature; thus it can be nearly constant for a limited temperature range.

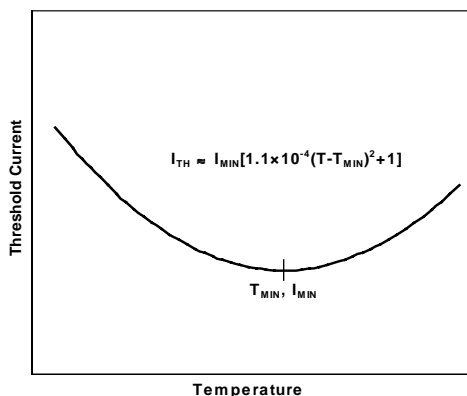

### NOTICE

The inherent design of this component causes it to be sensitive to electrostatic discharge (ESD). To prevent ESD-induced damage and/or degradation to equipment, take normal ESD precautions when handling this product.

### DANGER

The VCSEL is a class IIIb laser and should be treated as a potential eye hazard. Due to the size of the component, the applicable warning logotype, aperture label, and certification/identification label cannot be placed on the component itself. These labels can be found on the individual envelope in which the VCSEL unit is packaged, or attached to the shipping package.



# Fiber Optic LAN Components

## High Speed VCSEL 1.25Gbps VCSEL

# HFE408x-322

### ORDER GUIDE

Catalog Listing	Description
HFE4083-322	Unattenuated VCSEL with Back Monitor Photodiode - VCSEL Anode Common
HFE4084-322	Unattenuated VCSEL with Back Monitor Photodiode - VCSEL Cathode Common

### MOUNTING DIMENSIONS (for reference only): in./(mm)

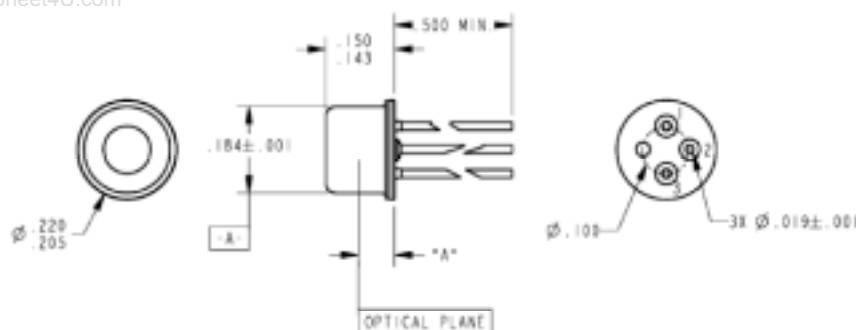

DIMENSION A = 0.078±0.004

### PINOUT

HFE4083-322		HFE4084-322	
Number	Function	Number	Function
1	K <sub>LD</sub>	1	A <sub>LD</sub>
2	K <sub>PD</sub> , A <sub>LD</sub>	2	K <sub>LD</sub> , A <sub>PD</sub>
3	A <sub>PD</sub>	3	K <sub>PD</sub>

### PINOUT DEFINITIONS

A <sub>LD</sub>	VCSEL Anode	A <sub>PD</sub>	Monitor Photodiode Anode
K <sub>LD</sub>	VCSEL Cathode	K <sub>PD</sub>	Monitor Photodiode Cathode

### WARRANTY/REMEDY

Honeywell warrants goods of its manufacture as being free of defective materials and faulty workmanship. Commencing with the date of shipment, Honeywell's warranty runs for 18 months. If warranted goods are returned to Honeywell during that period of coverage, Honeywell will repair or replace without charge those items it finds defective. The foregoing is Buyer's sole remedy and is **in lieu of all other warranties, expressed or implied, including those of merchantability and fitness for a particular purpose.**

While we provide application assistance, personally and through our literature, it is up to the customer to determine the suitability of the product in the application.

7/6/01

# Honeywell

Honeywell Inc.  
11 West Spring Street  
Freeport, Illinois 61032



Honeywell Inc.  
Optoelectronics Facility  
830 East Arapaho Road  
Richardson, Texas 75081

**Honeywell Control Systems Ltd.**  
Zodiac House  
Calleva Park  
Aldermaston, Berkshire  
RG7 8HW England

*Helping You Control Your World*

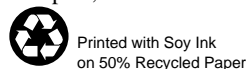

006694-1-EN IL50 GLO 797 Printed in USA

[www.DataSheet4U.com](http://www.DataSheet4U.com)

Specifications may change at any time without notice. The information we supply is believed to be accurate and reliable as of this printing. However, we assume no responsibility for its use.

### SALES AND SERVICE

Honeywell Sensing and Control serves its customers through a worldwide network of sales offices and distributors. For application assistance, current specifications, pricing or name of the nearest Authorized Distributor, contact a nearby sales office or call:

### TELEPHONE

1-800-367-6786 (USA)  
1-800-737-3360 (Canada)  
+49 (0) 89 35813310 (Germany)  
+65-580-3312 (Singapore)  
+44 (0) 118 981 9511 (UK)

### FAX

1-972-470-4326 (Customer Response Center)  
1-972-470-4549 (Fax on demand)  
+49 (0) 89 3599971 (Germany)  
+65 445 3033 (Singapore)  
+44 (0) 118 981 7513 (UK)

### INTERNET

<http://www.honeywell.com/sensing/VCSEL>  
[info.sc@honeywell.com](mailto:info.sc@honeywell.com)

# Fiber Optic Components

## GaAs 850 nm VCSEL

HFE4085-321

### ABSOLUTE MAXIMUM RATINGS

Parameter	Rating
Storage Temperature	-40 to +100 °C
Operating Temperature	0 to +70 °C
Lead Solder Temperature	260 °C, 10 sec.
Laser Continuous Forward Current, Heat Sunked	15 mA
Laser Reverse Breakdown Voltage ( $I_R=10 \mu A$ )	5 V @ 10 $\mu A$

### ELECTRO-OPTICAL CHARACTERISTICS ( $T_A=25^\circ C$ unless otherwise stated)

VCSEL Parameters	Test Condition	Symbol	Min.	Typ.	Max.	Units	Notes
Peak Operating Current	Adjustable to establish operating power	$I_{peak}$		12	20	mA	1
Optical Power Output	$I_F=12mA$	$P_o$	0.9	1.8	3.6	mW	1
Threshold Current		$I_{TH}$	1.5	3.5	6	mA	
Threshold Current Temperature Variation	$T_A = 0^\circ C$ to $70^\circ C$	$\Delta I_{TH}$	-1.5		1.5	mA	2
Slope Efficiency	$P_o = 1.3mW$	$\eta$	0.1	0.25	0.4	mW/mA	3
Slope Efficiency Temperature variation	$T_A = 0^\circ C$ to $70^\circ C$	$\Delta \eta / \Delta T$		-0.5		%/ $^\circ C$	
Peak Wavelength	$I_F=12mA$	$\lambda_p$	830	850	860	nm	
$\lambda_p$ Temperature Variation	$I_F=12mA$	$\Delta \lambda_p / \Delta T$		0.06		nm/ $^\circ C$	
Spectral Bandwidth, RMS	$I_F=12mA$	$\Delta \lambda$			0.85	nm	
Laser Forward Voltage	$I_F=12 mA$	$V_F$	1.6	1.8	2.2	V	
Laser Reverse Voltage	$I_R=10 \mu A$	$BVR_{LD}$	5	10		V	
Rise and Fall Times	Prebias Above Threshold, 20%-80%	$t_r/t_f$		100	300	ps	4
Relative Intensity Noise	1 GHz BW, $I_F=10mA$	RIN		-128	-122	dB/Hz	
Series Resistance	$I_F=12 mA$	$R_S$	18	25	40	Ohms	
Beam Divergence	$I_F=12 mA$	$\theta$	5	15	20	Degrees	5

#### Notes:

1. Operating power is set by the peak operating current  $I_{PEAK}=I_{BIAS}+I_{MODULATION}$ .
2. Operation at temperatures outside the specified range may result in the threshold current exceeding the maximums defined in the electro-optical characteristics table.
3. Slope efficiency is defined as  $\Delta P_o / \Delta I_F$  at a total power output of 1.3 mW.
4. Rise and fall times are sensitive to drive electronics, 200ps rise and fall times are achievable with Honeywell VCSELs.
5. Beam divergence is defined as the total included angle between the  $1/e^2$  intensity points.

# Fiber Optic Components

## GaAs 850 nm VCSEL

HFE4086-001

### ABSOLUTE MAXIMUM RATINGS

Parameter	Rating
Storage Temperature	-40 to +100 °C
Operating Temperature	0 to +70 °C
Lead Solder Temperature	260 °C, 10 sec.
Laser Continuous Forward Current, Heat Sunked	15 mA
Laser Reverse Breakdown Voltage ( $I_R=10 \mu A$ )	5 V @ 10 $\mu A$
PIN Photodiode reverse voltage	30V

www.DataSheet4U.com

### ELECTRO-OPTICAL CHARACTERISTICS ( $T_A=25^\circ C$ unless otherwise stated)

VCSEL Parameters	Test Condition	Symbol	Min.	Typ.	Max.	Units	Notes
Peak Operating Current	Adjustable to establish operating power	$I_{peak}$		12	20	mA	1
Optical Power Output	$I_F=12mA$	$P_o$	0.9	1.8	3.6	mW	1
Threshold Current		$I_{TH}$	1.5	3.5	6	mA	
Threshold Current Temperature Variation	$T_A = 0^\circ C$ to $70^\circ C$	$\Delta I_{TH}$	-1.5		1.5	mA	2
Slope Efficiency	$P_o = 1.3mW$	$\eta$	0.1	0.25	0.4	mW/mA	3
Slope Efficiency Temperature variation	$T_A = 0^\circ C$ to $70^\circ C$	$\Delta \eta / \Delta T$		-0.5		%/°C	
Peak Wavelength	$I_F=12mA$	$\lambda_p$	830	850	860	nm	
$\lambda_p$ Temperature Variation	$I_F=12mA$	$\Delta \lambda_p / \Delta T$		0.06		nm/°C	
Spectral Bandwidth, RMS	$I_F=12mA$	$\Delta \lambda$			0.85	nm	
Laser Forward Voltage	$I_F=12 mA$	$V_F$	1.6	1.8	2.2	V	
Laser Reverse Voltage	$I_R=10 \mu A$	$BVR_{LD}$	5	10		V	
Rise and Fall Times	Prebias Above Threshold, 20%-80%	$t_r/t_f$		100	300	ps	4
Relative Intensity Noise	1 GHz BW, $I_F=12mA$	RIN		-128	-122	dB/Hz	
Series Resistance	$I_F=12 mA$	$R_S$	18	25	40	Ohms	
Beam Divergence	$I_F=12 mA$	$\theta$	5	15	20	Degrees	5

#### Notes:

1. Operating power is set by the peak operating current  $I_{PEAK}=I_{BIAS}+I_{MODULATION}$ .
2. Operation at temperatures outside the specified range may result in the threshold current exceeding the maximums defined in the electro-optical characteristics table.
3. Slope efficiency is defined as  $\Delta P_o / \Delta I_F$  at a total power output of 1.3 mW.
4. Rise and fall times are sensitive to drive electronics, 200ps rise and fall times are achievable with Honeywell VCSELs.
5. Beam divergence is defined as the total included angle between the  $1/e^2$  intensity points.

### LC Connectorized High Speed VCSEL 2.5 Gbps

#### FEATURES

- Designed for small form factor transceivers
- Prealigned connector sleeve that is compatible with the LC standard (LC is a trademark of Lucent Technologies)
- Designed for drive currents
- Optimized for low dependence of electrical properties over temperature
- High speed  $\geq 1$  GHz
- Two different laser/ photodiode polarities
- Attenuating coating
- Packaged with a photodetector



The HFE419x-521 is a high-performance 850 nm VCSEL (Vertical Cavity Surface-Emitting Laser) packaged for high-speed data communications. This product combines all the performance advantages of the VCSEL with a custom designed power monitor diode. The power monitor diode can be used with appropriate feedback control circuitry to set a maximum power level for each VCSEL. In addition, built-in power attenuation reduces the effective slope efficiency. These combined features simplify design for high data rate communication and eye safety.

Packaged in a fiber receptacle sleeve, this high radiance VCSEL is designed to convert electrical current into optical power that can be used in fiber optic communications and other applications. As the current varies above threshold, the light intensity increases proportionally.

The HFE419x-521 is designed to be used with inexpensive silicon or gallium arsenide detectors, but excellent performance can also be achieved with some indium gallium arsenide detectors.

The low drive current requirement makes direct drive from PECL (Positive Emitter Coupled Logic) or EML (Emitter Coupled Logic) gates possible and eases driver design.

The HFE419x-521 is a prealigned and focused fiber optic transmitter designed to interface with 50/125 and 62.5/125  $\mu\text{m}$  multimode fiber.

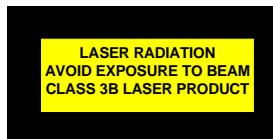

# Fiber Optic LAN Components

## LC Connectorized VCSEL 2.5Gbps

HFE419x-521

### ABSOLUTE MAXIMUM RATINGS

Parameter	Rating
Storage Temperature	-40 to +85°C
Operating Temperature	0 to +70°C
Lead Solder Temperature	260°C, 10 sec.
Continuous Optical Output Power (Any Current)	5 mW
Laser Diode Reverse Voltage ( $I_R=10 \mu A$ )	5 V
Laser Continuous Forward Current, Heat-Sinked	15 mA
PIN Photodiode Forward Current	10 mA

### NOTICE

Stresses greater than those listed under “Absolute Maximum Ratings” may cause permanent damage to the device. This is a stress rating only and functional operation of the device at these or any other conditions above those indicated in the operations section for extended periods of time may affect reliability.

www.DataSheet4U.com

### ELECTRO-OPTICAL CHARACTERISTICS ( $T_A=25^\circ C$ unless otherwise stated)

VCSEL Parameters	Test Condition	Symbol	Min.	Typ.	Max.	Units	Notes
Peak Fiber Coupled Optical Power (See threshold current and slope efficiency which control power output)	$I_F=9$ mA Peak 50/125 $\mu m$ fiber NA=0.20	$P_{OC}$		350		$\mu W$	1
Threshold Current		$I_{TH}$	1	3	5	mA	
Threshold Current Temperature Variation	$T_A = 0^\circ C$ to $70^\circ C$	$\Delta I_{TH}$	-1.5		1.5	mA	2
Slope Efficiency	$P_{OC}=0.5$ mW	$\eta$	0.028		0.14	mW/mA	3
Slope Efficiency Temperature Variation	$T_A = 0^\circ C$ to $70^\circ C$	$\Delta\eta/\Delta T$		-6000		PPM/ $^\circ C$	
Peak Wavelength	$I_F=9$ mA	$\lambda_p$	830	850	860	nm	
$\lambda_p$ Temp Coefficient	$I_F=9$ mA	$\Delta\lambda_p/\Delta T$		0.06		nm/ $^\circ C$	
Spectral Bandwidth	$I_F=9$ mA, FWHM	$\Delta\lambda$			0.85	nm	
Laser Forward Voltage	$I_F=9$ mA	$V_F$		1.8	2.2	V	
Laser Reverse Voltage	$I_R=10 \mu A$	$BVR_{LD}$		-10		V	
Rise and Fall Time	Bias Above Threshold (20%-80%)	$t_R$ $t_F$			130 150	ps	4
Relative Intensity Noise	1 GHz BW	RIN		-130	-122	dB/Hz	
Series Resistance	$I_F=9$ mA	$R_S$	18	25	40	Ohms	
Series Resistance Temperature Coefficient	$I_F=9$ mA, $0^\circ C$ to $70^\circ C$	$dR_S/dT$		-3000		PPM/ $^\circ C$	

Photodiode Parameters	Test Condition	Symbol	Min.	Typ.	Max.	Units	Notes
Monitor Current	$P_{OC}=0.5$ mW	$I_{PD}$		0.42		mA	
Monitor Current Temperature Variation	$P_{OC}=0.5$ mW	$\Delta I_{PD}/\Delta T$		0.2		%/ $^\circ C$	
Dark Current	$P_o=0$ mW, $V_R=3$ V	$I_D$			20	nA	
PD Reverse Voltage	$P_o=0$ mW, $I_R=10 \mu A$	$BVR_{PD}$	30	115		V	5
PD Capacitance	$V_R=0$ V, Freq=1 MHz $V_R=3$ V, Freq=1 MHz	C		75 40	100 55	pF	

# Fiber Optic Components

## LC Connectorized VCSEL 2.5 Gbps

HFE419x-521

### Notes:

1. Operating power is set by the peak operating current  
 $I_{PEAK} = I_{BIAS} + I_{MODULATION}$
2. Operation at temperatures outside the specified range may result in the threshold current exceeding the maximums defined in the electro-optical characteristics table.
3. Slope efficiency is defined as  $\Delta P_o / \Delta I_F$  at a total power output of 0.5 mW. Slope efficiency is intentionally lowered to the values shown by optical attenuation.
4. Rise and fall times are sensitive to drive electronics.
5. To safeguard the VCSEL from current spike damage, short the VCSEL anode and cathode to each other during photodiode BVR verification testing.

www.DataSheet4U.com

### TYPICAL PERFORMANCE CURVES

**Emitted Power vs. Current:** Power varies approximately linearly with current above threshold.

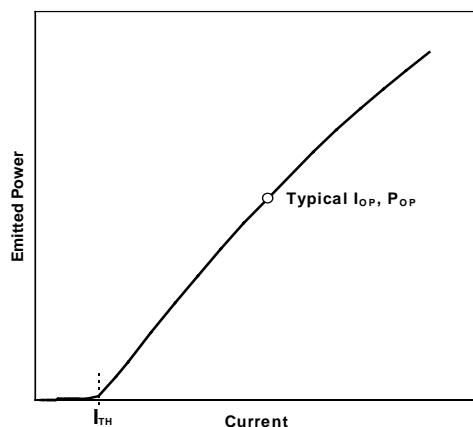

**Emission Intensity vs. Wavelength:** Typical 10 mA spectrum comprises multiple lines corresponding to multiple transverse modes.

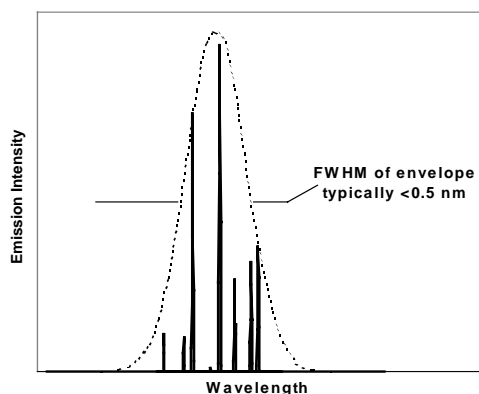

**Threshold Current vs. Temperature:** Threshold current varies parabolically with temperature; thus it can be nearly constant for a limited temperature range.

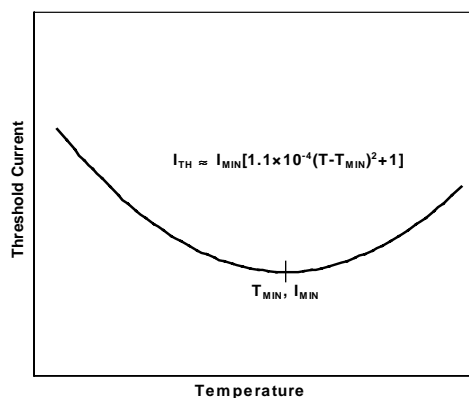

### NOTICE

The inherent design of this component causes it to be sensitive to electrostatic discharge (ESD). To prevent ESD-induced damage and/or degradation to equipment, take normal ESD precautions when handling this product.



The VCSEL is a class IIIb laser and should be treated as a potential eye hazard. Due to the size of the component, the applicable warning logotype, aperture label, and certification/identification label cannot be placed on the component itself. These labels can be found on the individual envelope in which the VCSEL unit is packaged, or attached to the shipping package.

# Fiber Optic LAN Components

## LC Connectorized VCSEL 2.5 Gbps

# HFE419x-521

### ORDER GUIDE

Catalog Listing	Description
HFE4190-521	Attenuated VCSEL with Back Monitor Photodiode - VCSEL Anode Common
HFE4191-521	Attenuated VCSEL with Back Monitor Photodiode - VCSEL Cathode Common

### MOUNTING DIMENSIONS (for reference only): in./(mm)

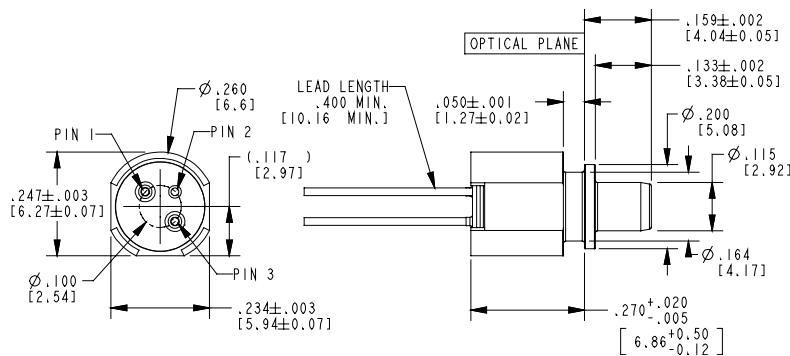

### PINOUT

HFE4190-521		HFE4191-521	
Number	Function	Number	Function
1	K <sub>LD</sub>	1	A <sub>LD</sub>
2	K <sub>PD</sub> , A <sub>LD</sub>	2	K <sub>LD</sub> , A <sub>PD</sub>
3	A <sub>PD</sub>	3	K <sub>PD</sub>

### PINOUT DEFINITIONS

A <sub>LD</sub>	VCSEL Anode	A <sub>PD</sub>	Monitor Photodiode Anode
K <sub>LD</sub>	VCSEL Cathode	K <sub>PD</sub>	Monitor Photodiode Cathode

### WARRANTY/REMEDY

Honeywell warrants goods of its manufacture as being free of defective materials and faulty workmanship. Commencing with the date of shipment, Honeywell's warranty runs for 18 months. If warranted goods are returned to Honeywell during that period of coverage, Honeywell will repair or replace without charge those items it finds defective. The foregoing is Buyer's sole remedy and is **in lieu of all other warranties, expressed or implied, including those of merchantability and fitness for a particular purpose.**

7/23/01

# Honeywell

Honeywell Inc.  
11 West Spring Street  
Freeport, Illinois 61032



Honeywell Inc.  
Optoelectronics Facility  
830 East Arapaho Road  
Richardson, Texas 75081

**Honeywell Control Systems Ltd.**  
Zodiac House  
Calleva Park  
Aldermaston, Berkshire  
RG7 8HW England

*Helping You Control Your World*

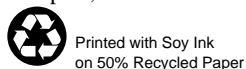

006694-1-EN IL50 GLO 797 Printed in USA

[www.DataSheet4U.com](http://www.DataSheet4U.com)

While we provide application assistance, personally and through our literature, it is up to the customer to determine the suitability of the product in the application.

Specifications may change at any time without notice. The information we supply is believed to be accurate and reliable as of this printing. However, we assume no responsibility for its use.

### SALES AND SERVICE

Honeywell Sensing and Control serves its customers through a worldwide network of sales offices and distributors. For application assistance, current specifications, pricing or name of the nearest Authorized Distributor, contact a nearby sales office or call:

### TELEPHONE

1-800-367-6786 (USA)  
1-800-737-3360 (Canada)  
+49 (0) 89 35813310 (Germany)  
+65-580-3312 (Singapore)  
+44 (0) 118 981 9511 (UK)

### FAX

1-972-470-4326 (Customer Response Center)  
1-972-470-4549 (Fax on demand)  
+49 (0) 89 3599971 (Germany)  
+65 445 3033 (Singapore)  
+44 (0) 118 981 7513 (UK)

### INTERNET

<http://www.honeywell.com/sensing/VCSEL>  
[info.sc@honeywell.com](mailto:info.sc@honeywell.com)

### LC Connectorized High Speed VCSEL 2.5 Gbps

#### FEATURES

- Designed for small form factor transceivers
- Prealigned connector sleeve that is compatible with the LC standard (LC is a trademark of Lucent Technologies)
- Designed for drive currents
- Optimized for low dependence of electrical properties over temperature
- High speed  $\geq 1$  GHz
- Two different laser/ photodiode polarities
- Attenuating coating
- Packaged with a photodetector



The HFE419x-541 is a high-performance 850 nm VCSEL (Vertical Cavity Surface-Emitting Laser) packaged for high-speed data communications. This product combines all the performance advantages of the VCSEL with a custom designed power monitor diode. The power monitor diode can be used with appropriate feedback control circuitry to set a maximum power level for each VCSEL. In addition, built-in power attenuation reduces the effective slope efficiency. These combined features simplify design for high data rate communication and eye safety.

Packaged in a fiber receptacle sleeve, this high radiance VCSEL is designed to convert electrical current into optical power that can be used in fiber optic communications and other applications. As the current varies above threshold, the light intensity increases proportionally.

The HFE419x-541 is designed to be used with inexpensive silicon or gallium arsenide detectors, but excellent performance can also be achieved with some indium gallium arsenide detectors.

The low drive current requirement makes direct drive from PECL (Positive Emitter Coupled Logic) or EML (Emitter Coupled Logic) gates possible and eases driver design.

The HFE419x-541 is a prealigned and focused fiber optic transmitter designed to interface with 50/125 and 62.5/125  $\mu\text{m}$  multimode fiber.

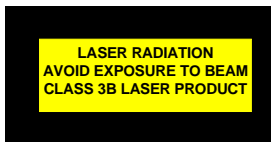



# Fiber Optic LAN Components

## LC Connectorized VCSEL 2.5Gbps

HFE419x-541

### ABSOLUTE MAXIMUM RATINGS

Parameter	Rating
Storage Temperature	-40 to +85°C
Operating Temperature	0 to +70°C
Lead Solder Temperature	260°C, 10 sec.
Continuous Optical Output Power (Any Current)	5 mW
Laser Diode Reverse Voltage ( $I_R=10 \mu A$ )	5 V
Laser Continuous Forward Current, Heat-Sinked	12 mA
PIN Photodiode Forward Current	10 mA

### NOTICE

Stresses greater than those listed under “Absolute Maximum Ratings” may cause permanent damage to the device. This is a stress rating only and functional operation of the device at these or any other conditions above those indicated in the operations section for extended periods of time may affect reliability.

www.DataSheet4U.com

### ELECTRO-OPTICAL CHARACTERISTICS ( $T_A=25^\circ C$ unless otherwise stated)

VCSEL Parameters	Test Condition	Symbol	Min.	Typ.	Max.	Units	Notes
Peak Fiber Coupled Optical Power (See threshold current and slope efficiency which control power output)	$I_F=7 \text{ mA av.}$ 50/125 $\mu\text{m}$ fiber NA=0.20	$P_{OC}$		500		$\mu\text{W}$	1
Threshold Current		$I_{TH}$	1	2	3	mA	
Threshold Current Temperature Variation	$T_A = 0^\circ\text{C to } 70^\circ\text{C}$	$\Delta I_{TH}$	-1.5		1.5	mA	2
Slope Efficiency		$\eta$	0.04		0.16	mW/mA	3
Slope Efficiency Temperature Variation	$T_A = 0^\circ\text{C to } 70^\circ\text{C}$	$\Delta\eta/\Delta T$		-6000		PPM/ $^\circ\text{C}$	
Peak Wavelength	$I_F=7 \text{ mA}$	$\lambda_p$	830	850	860	Nm	
$\lambda_p$ Temp Coefficient	$I_F=7 \text{ mA}$	$\Delta\lambda_p/\Delta T$		0.06		nm/ $^\circ\text{C}$	
Spectral Bandwidth	$I_F=7 \text{ mA, FWHM}$	$\Delta\lambda$			0.85	nm	
Laser Forward Voltage	$I_F=7 \text{ mA}$	$V_F$		1.8	2.2	V	
Laser Reverse Voltage	$I_R=10 \mu\text{A}$	$BVR_{LD}$		-10		V	
Rise and Fall Time	Bias Above Threshold (20%-80%)	$t_R$ $t_F$			130 150	ps	4
Relative Intensity Noise	1 GHz BW	RIN		-130	-122	dB/Hz	
Series Resistance	$I_F=7 \text{ mA}$	$R_S$	22	35	55	Ohms	
Series Resistance Temperature Coefficient	$I_F=7 \text{ mA, } 0^\circ\text{C to } 70^\circ\text{C}$	$dR_S/dT$		-3000		PPM/ $^\circ\text{C}$	

Photodiode Parameters	Test Condition	Symbol	Min.	Typ.	Max.	Units	Notes
Monitor Current	$P_{OC}=0.5 \text{ mW}$	$I_{PD}$		0.35		mA	
Monitor Current Temperature Variation	$P_{OC}=0.5 \text{ mW}$	$\Delta I_{PD}/\Delta T$		0.2		%/ $^\circ\text{C}$	
Dark Current	$P_o=0 \text{ mW, } V_R=3 \text{ V}$	$I_D$			20	nA	
PD Reverse Voltage	$P_o=0 \text{ mW, } I_R=10 \mu\text{A}$	$BVR_{PD}$	30	115		V	5
PD Capacitance	$V_R=0 \text{ V, Freq}=1 \text{ MHz}$ $V_R=3 \text{ V, Freq}=1 \text{ MHz}$	C		75 40	100 55	pF	

# Fiber Optic Components

## LC Connectorized VCSEL 2.5 Gbps

HFE419x-541

### Notes:

1. Operating power is set by the peak operating current  
 $I_{PEAK} = I_{BIAS} + I_{MODULATION}$
2. Operation at temperatures outside the specified range may result in the threshold current exceeding the maximums defined in the electro-optical characteristics table.
3. Slope efficiency is defined as  $\Delta P_o / \Delta I_F$  at a total power output of 0.5 mW. Slope efficiency is intentionally lowered to the values shown by optical attenuation.
4. Rise and fall times are sensitive to drive electronics.
5. To safeguard the VCSEL from current spike damage, short the VCSEL anode and cathode to each other during photodiode BVR verification testing.

www.DataSheet4U.com

### TYPICAL PERFORMANCE CURVES

**Emitted Power vs. Current:** Power varies approximately linearly with current above threshold.

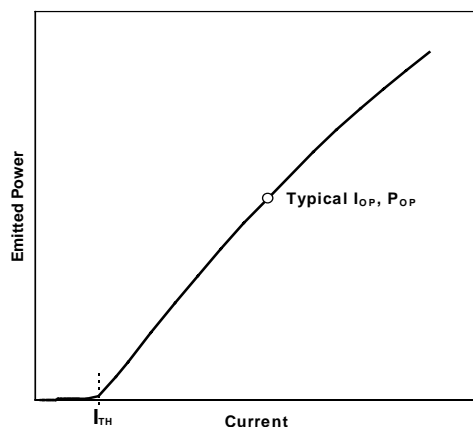

**Emission Intensity vs. Wavelength:** Typical 10 mA spectrum comprises multiple lines corresponding to multiple transverse modes.

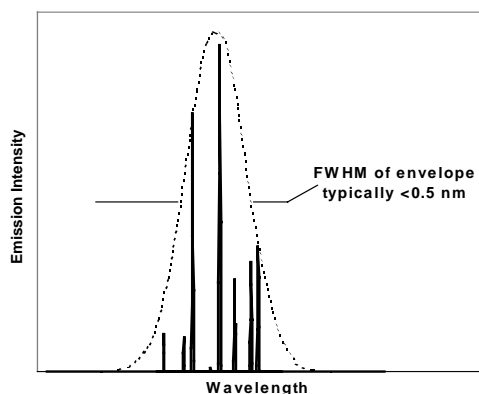

**Threshold Current vs. Temperature:** Threshold current varies parabolically with temperature; thus it can be nearly constant for a limited temperature range.

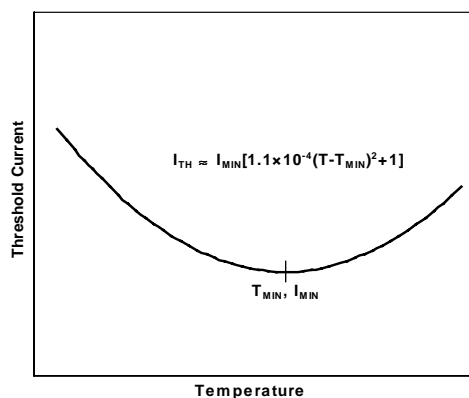

### NOTICE

The inherent design of this component causes it to be sensitive to electrostatic discharge (ESD). To prevent ESD-induced damage and/or degradation to equipment, take normal ESD precautions when handling this product.



The VCSEL is a class IIIb laser and should be treated as a potential eye hazard. Due to the size of the component, the applicable warning logotype, aperture label, and certification/identification label cannot be placed on the component itself. These labels can be found on the individual envelope in which the VCSEL unit is packaged, or attached to the shipping package.

# Fiber Optic LAN Components

## LC Connectorized VCSEL 2.5 Gbps

# HFE419x-541

### ORDER GUIDE

Catalog Listing	Description
HFE4190-541	Attenuated VCSEL with Back Monitor Photodiode - VCSEL Anode Common
HFE4191-541	Attenuated VCSEL with Back Monitor Photodiode - VCSEL Cathode Common

### MOUNTING DIMENSIONS (for reference only): in./(mm)

Current Dimension

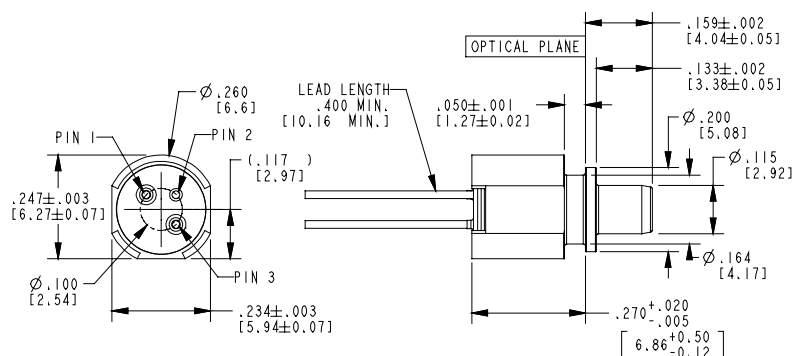

### PINOUT

HFE4190-541		HFE4191-541	
Number	Function	Number	Function
1	K <sub>LD</sub>	1	A <sub>LD</sub>
2	K <sub>PD</sub> , A <sub>LD</sub>	2	K <sub>LD</sub> , A <sub>PD</sub>
3	A <sub>PD</sub>	3	K <sub>PD</sub>

### PINOUT DEFINITIONS

A <sub>LD</sub>	VCSEL Anode	A <sub>PD</sub>	Monitor Photodiode Anode
K <sub>LD</sub>	VCSEL Cathode	K <sub>PD</sub>	Monitor Photodiode Cathode

### WARRANTY/REMEDY

Honeywell warrants goods of its manufacture as being free of defective materials and faulty workmanship. Commencing with the date of shipment, Honeywell's warranty runs for 18 months. If warranted goods are returned to Honeywell during that period of coverage, Honeywell will repair or replace without charge those items it finds defective. The foregoing is Buyer's sole remedy and is **in lieu of all other warranties, expressed or implied, including those of merchantability and fitness for a particular purpose.**

03/08/02

# Honeywell

Honeywell Inc.  
11 West Spring Street  
Freeport, Illinois 61032



Honeywell Inc.  
Optoelectronics Facility  
830 East Arapaho Road  
Richardson, Texas 75081

**Honeywell Control Systems Ltd.**  
Zodiac House  
Calleva Park  
Aldermaston, Berkshire  
RG7 8HW England

*Helping You Control Your World*

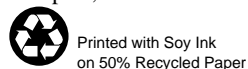

006694-1-EN IL50 GLO 797 Printed in USA

[www.DataSheet4U.com](http://www.DataSheet4U.com)

While we provide application assistance, personally and through our literature, it is up to the customer to determine the suitability of the product in the application.

Specifications may change at any time without notice. The information we supply is believed to be accurate and reliable as of this printing. However, we assume no responsibility for its use.

### SALES AND SERVICE

Honeywell Sensing and Control serves its customers through a worldwide network of sales offices and distributors. For application assistance, current specifications, pricing or name of the nearest Authorized Distributor, contact a nearby sales office or call:

### TELEPHONE

1-800-367-6786 (USA)  
1-800-737-3360 (Canada)  
+49 (0) 89 35813310 (Germany)  
+65-580-3312 (Singapore)  
+44 (0) 118 981 9511 (UK)

### FAX

1-972-470-4326 (Customer Response Center)  
1-972-470-4549 (Fax on demand)  
+49 (0) 89 3599971 (Germany)  
+65 445 3033 (Singapore)  
+44 (0) 118 981 7513 (UK)

### INTERNET

<http://www.honeywell.com/VCSEL>  
[VCSEL@honeywell.com](mailto:VCSEL@honeywell.com)

# Fiber Optic Components

## LC Connectorized VCSEL 2.5 Gbps

HFE419x-541

Future Dimension (available starting April 2002)

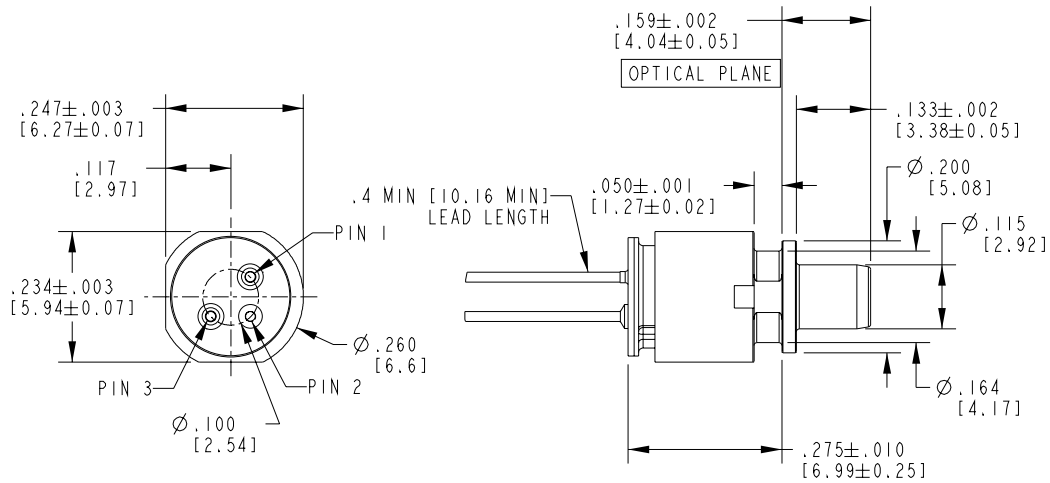

PIN 1	PIN 2	PIN 3
VCSEL ANODE	VCSEL CATHODE/PD ANODE	PD CATHODE

For application help: call 1-800-537-6945

Preliminary

Honeywell • 5

www.DataSheet4U.com

## Fiber Optic LAN Components

## HFE439x-521

### SC Connectorized High Speed VCSEL 2.5Gbps

*Preliminary*

#### FEATURES

- Prealigned connector sleeve that is compatible with the SC standard
- Designed for drive currents between 5 and 15 mA
- Optimized for low dependence of electrical properties over temperature
- High speed  $\geq 1$  GHz
- Two different laser/ photodiode polarities
- Attenuating coating
- Packaged with a photodetector



The HFE439x-521 is a high-performance 850 nm VCSEL (Vertical Cavity Surface-Emitting Laser) packaged for high-speed data communications. This product combines all the performance advantages of the VCSEL with a custom designed power monitor diode. The power monitor diode can be used with appropriate feedback control circuitry to set a maximum power level for each VCSEL. In addition, built-in power attenuation reduces the effective slope efficiency. These combined features simplify design for high data rate communication and eye safety.

Packaged in a fiber receptacle sleeve, this high radiance VCSEL is designed to convert electrical current into optical power that can be used in fiber optic communications and other applications. As the current varies above threshold, the light intensity increases proportionally.

The HFE439x-521 is designed to be used with inexpensive silicon or gallium arsenide detectors, but excellent performance can also be achieved with some indium gallium arsenide detectors.

The low drive current requirement makes direct drive from PECL (Positive Emitter Coupled Logic) or EML (Emitter Coupled Logic) gates possible and eases driver design.

The HFE439x-521 is a prealigned and focused fiber optic transmitter designed to interface with 50/125 and 62.5/125  $\mu\text{m}$  multimode fiber.

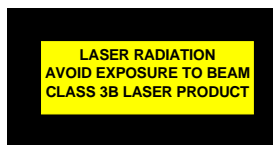

# Fiber Optic LAN Components

## SC Connectorized VCSEL 2.5Gbps

HFE439x-521  
Preliminary

### ABSOLUTE MAXIMUM RATINGS

Parameter	Rating
Storage Temperature	-40 to +85°C
Operating Temperature	0 to +70°C
Lead Solder Temperature	260°C, 10 sec.
Continuous Optical Output Power (Any Current)	5 mW
Laser Diode Reverse Voltage ( $I_R=10 \mu A$ )	5 V
Laser Continuous Forward Current, Heat-Sinked	15 mA
PIN Photodiode Forward Current	10 mA

### NOTICE

Stresses greater than those listed under “Absolute Maximum Ratings” may cause permanent damage to the device. This is a stress rating only and functional operation of the device at these or any other conditions above those indicated in the operations section for extended periods of time may affect reliability.

www.DataSheet4U.com

### ELECTRO-OPTICAL CHARACTERISTICS ( $T_A=25^\circ C$ unless otherwise stated)

VCSEL Parameters	Test Condition	Symbol	Min.	Typ.	Max.	Units	Notes
Peak Fiber Coupled Optical Power (See threshold current and slope efficiency which control power output)	$I_F=9$ mA Peak 50/125 $\mu m$ fiber NA=0.20	$P_{OC}$		350		$\mu W$	1
Threshold Current		$I_{TH}$	1	3	5	mA	
Threshold Current Temperature Variation	$T_A = 0^\circ C$ to $70^\circ C$	$\Delta I_{TH}$	-1.5		1.5	mA	2
Slope Efficiency	$P_{OC}=0.5$ mW	$\eta$	0.028		0.14	mW/mA	3
Slope Efficiency Temperature Variation	$T_A = 0^\circ C$ to $70^\circ C$	$\Delta\eta/\Delta T$		-6000		PPM/ $^\circ C$	
Peak Wavelength	$I_F=9$ mA	$\lambda_p$	830	850	860	nm	
$\lambda_p$ Temp Coefficient	$I_F=9$ mA	$\Delta\lambda_p/\Delta T$		0.06		nm/ $^\circ C$	
Spectral Bandwidth	$I_F=9$ mA, FWHM	$\Delta\lambda$			0.85	nm	
Laser Forward Voltage	$I_F=9$ mA	$V_F$		1.8	2.2	V	
Laser Reverse Voltage	$I_R=10 \mu A$	$BVR_{LD}$		-10		V	
Rise and Fall Time	Bias Above Threshold (20%-80%)	$t_R$ $t_F$			130 150	ps	4
Relative Intensity Noise	1 GHz BW	RIN		-130	-122	dB/Hz	
Series Resistance	$I_F=9$ mA	$R_S$	18	25	40	Ohms	
Series Resistance Temperature Coefficient	$I_F=9$ mA, $0^\circ C$ to $70^\circ C$	$dR_S/dT$		-3000		PPM/ $^\circ C$	

Photodiode Parameters	Test Condition	Symbol	Min.	Typ.	Max.	Units	Notes
Monitor Current	$P_{OC}=0.5$ mW	$I_{PD}$		0.42		mA	
Monitor Current Temperature Variation	$P_{OC}=0.5$ mW	$\Delta I_{PD}/\Delta T$		0.2		%/ $^\circ C$	
Dark Current	$P_o=0$ mW, $V_R=3$ V	$I_D$			20	nA	
PD Reverse Voltage	$P_o=0$ mW, $I_R=10 \mu A$	$BVR_{PD}$	30	115		V	5
PD Capacitance	$V_R=0$ V, Freq=1 MHz $V_R=3$ V, Freq=1 MHz	C		75 40	100 55	pF	

# Fiber Optic Components

## SC Connectorized VCSEL 2.5Gbps

HFE439x-521  
Preliminary

### Notes:

1. Operating power is set by the peak operating current  

$$I_{PEAK} = I_{BIAS} + I_{MODULATION}$$
2. Operation at temperatures outside the specified range may result in the threshold current exceeding the maximums defined in the electro-optical characteristics table.
3. Slope efficiency is defined as  $\Delta P_o / \Delta I_F$  at a total power output of 0.5 mW. Slope efficiency is intentionally lowered to the values shown by optical attenuation.
4. Rise and fall times are sensitive to drive electronics.
5. To safeguard the VCSEL from current spike damage, short the VCSEL anode and cathode to each other during photodiode BVR verification testing.

www.DataSheet4U.com

### TYPICAL PERFORMANCE CURVES

**Emitted Power vs. Current:** Power varies approximately linearly with current above threshold.

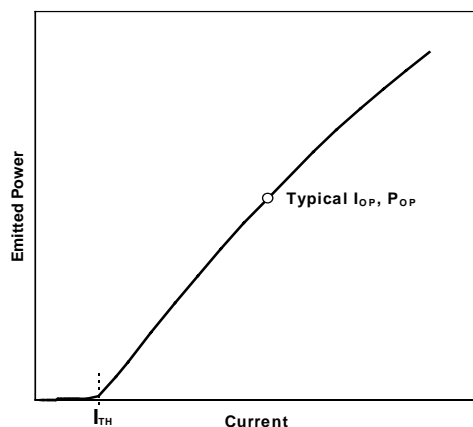

**Emission Intensity vs. Wavelength:** Typical 10 mA spectrum comprises multiple lines corresponding to multiple transverse modes.

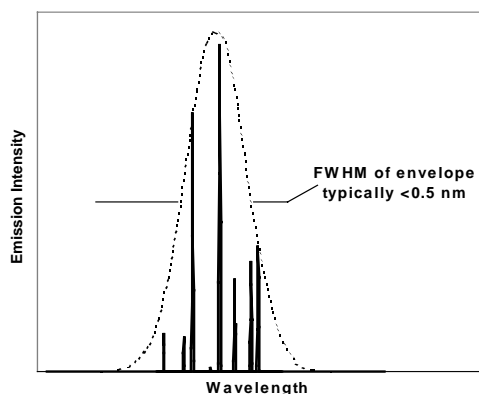

**Threshold Current vs. Temperature:** Threshold current varies parabolically with temperature; thus it can be nearly constant for a limited temperature range.

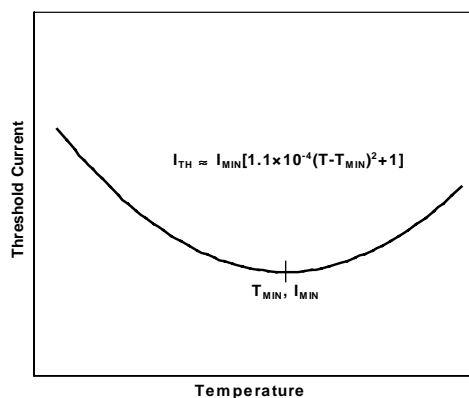

### NOTICE

The inherent design of this component causes it to be sensitive to electrostatic discharge (ESD). To prevent ESD-induced damage and/or degradation to equipment, take normal ESD precautions when handling this product.



The VCSEL is a class IIIb laser and should be treated as a potential eye hazard. Due to the size of the component, the applicable warning logotype, aperture label, and certification/identification label cannot be placed on the component itself. These labels can be found on the individual envelope in which the VCSEL unit is packaged, or attached to the shipping package.

# Fiber Optic LAN Components

## SC Connectorized VCSEL 2.5Gbps

# HFE439x-521

## Preliminary

### ORDER GUIDE

Catalog Listing	Description
HFE4390-521	Attenuated VCSEL with Back Monitor Photodiode - VCSEL Anode Common
HFE4391-521	Attenuated VCSEL with Back Monitor Photodiode - VCSEL Cathode Common

### MOUNTING DIMENSIONS (for reference only): in./(mm)

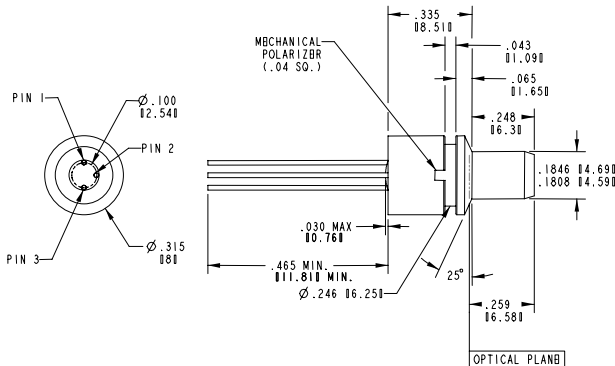

While we provide application assistance, personally and through our literature, it is up to the customer to determine the suitability of the product in the application.

Specifications may change at any time without notice. The information we supply is believed to be accurate and reliable as of this printing. However, we assume no responsibility for its use.

### SALES AND SERVICE

Honeywell Sensing and Control serves its customers through a worldwide network of sales offices and distributors. For application assistance, current specifications, pricing or name of the nearest Authorized Distributor, contact a nearby sales office or call:

### TELEPHONE

1-800-367-6786 (USA)  
 1-800-737-3360 (Canada)  
 +49 (0) 89 35813310 (Germany)  
 +65-580-3312 (Singapore)  
 +44 (0) 118 981 9511 (UK)

### FAX

1-972-470-4326 (Customer Response Center)  
 1-972-470-4549 (Fax on demand)  
 +49 (0) 89 3599971 (Germany)  
 +65 445 3033 (Singapore)  
 +44 (0) 118 981 7513 (UK)

### INTERNET

<http://www.honeywell.com/sensing/VCSEL>  
[info.sc@honeywell.com](mailto:info.sc@honeywell.com)

### PINOUT

HFE4390-521		HFE4391-521	
Number	Function	Number	Function
1	K <sub>LD</sub>	1	A <sub>LD</sub>
2	K <sub>PD</sub> , A <sub>LD</sub>	2	K <sub>LD</sub> , A <sub>PD</sub>
3	A <sub>PD</sub>	3	K <sub>PD</sub>

### PINOUT DEFINITIONS

A <sub>LD</sub>	VCSEL Anode	A <sub>PD</sub>	Monitor Photodiode Anode
K <sub>LD</sub>	VCSEL Cathode	K <sub>PD</sub>	Monitor Photodiode Cathode

### WARRANTY/REMEDY

Honeywell warrants goods of its manufacture as being free of defective materials and faulty workmanship. Commencing with the date of shipment, Honeywell's warranty runs for 18 months. If warranted goods are returned to Honeywell during that period of coverage, Honeywell will repair or replace without charge those items it finds defective. The foregoing is Buyer's sole remedy and is **in lieu of all other warranties, expressed or implied, including those of merchantability and fitness for a particular purpose.**

7/23/01

# Honeywell

Honeywell Inc.  
 11 West Spring Street  
 Freeport, Illinois 61032



Honeywell Inc.  
 Optoelectronics Facility  
 830 East Arapaho Road  
 Richardson, Texas 75081

**Honeywell Control Systems Ltd.**  
 Zodiac House  
 Calleva Park  
 Aldermaston, Berkshire  
 RG7 8HW England

*Helping You Control Your World*

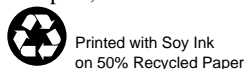

Printed with Soy Ink  
 on 50% Recycled Paper

006694-1-EN IL50 GLO 797 Printed in USA

[www.DataSheet4U.com](http://www.DataSheet4U.com)



### SC Connectorized High Speed VCSEL 2.5Gbps

#### FEATURES

- Prealigned connector sleeve that is compatible with the SC standard
- Designed for drive currents between 3 and 12 mA
- Optimized for low dependence of electrical properties over temperature
- High speed  $\geq 1$  GHz
- Two different laser/ photodiode polarities
- Attenuating coating
- Packaged with a photodetector



The HFE439x-541 is a high-performance 850 nm VCSEL (Vertical Cavity Surface-Emitting Laser) packaged for high-speed data communications. This product combines all the performance advantages of the VCSEL with a custom designed power monitor diode. The power monitor diode can be used with appropriate feedback control circuitry to set a maximum power level for each VCSEL. In addition, built-in power attenuation reduces the effective slope efficiency. These combined features simplify design for high data rate communication and eye safety.

Packaged in a fiber receptacle sleeve, this high radiance VCSEL is designed to convert electrical current into optical power that can be used in fiber optic communications and other applications. As the current varies above threshold, the light intensity increases proportionally.

The HFE439x-541 is designed to be used with inexpensive silicon or gallium arsenide detectors, but excellent performance can also be achieved with some indium gallium arsenide detectors.

The low drive current requirement makes direct drive from PECL (Positive Emitter Coupled Logic) or EML (Emitter Coupled Logic) gates possible and eases driver design.

The HFE439x-541 is a prealigned and focused fiber optic transmitter designed to interface with 50/125 and 62.5/125  $\mu\text{m}$  multimode fiber.

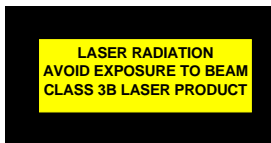

# Fiber Optic LAN Components

## LC Connectorized VCSEL 2.5Gbps

HFE439x-541

### ABSOLUTE MAXIMUM RATINGS

Parameter	Rating
Storage Temperature	-40 to +85°C
Operating Temperature	0 to +70°C
Lead Solder Temperature	260°C, 10 sec.
Continuous Optical Output Power (Any Current)	5 mW
Laser Diode Reverse Voltage ( $I_R=10 \mu A$ )	5 V
Laser Continuous Forward Current, Heat-Sinked	12 mA
PIN Photodiode Forward Current	10 mA

### NOTICE

Stresses greater than those listed under “Absolute Maximum Ratings” may cause permanent damage to the device. This is a stress rating only and functional operation of the device at these or any other conditions above those indicated in the operations section for extended periods of time may affect reliability.

www.DataSheet4U.com

### ELECTRO-OPTICAL CHARACTERISTICS ( $T_A=25^\circ C$ unless otherwise stated)

VCSEL Parameters	Test Condition	Symbol	Min.	Typ.	Max.	Units	Notes
Peak Fiber Coupled Optical Power (See threshold current and slope efficiency which control power output)	$I_F=7 \text{ mA av.}$ 50/125 $\mu\text{m}$ fiber NA=0.20	$P_{OC}$		500		$\mu\text{W}$	1
Threshold Current		$I_{TH}$	1	2	3	mA	
Threshold Current Temperature Variation	$T_A = 0^\circ\text{C to } 70^\circ\text{C}$	$\Delta I_{TH}$	-1.5		1.5	mA	2
Slope Efficiency		$\eta$	0.04		0.16	mW/mA	3
Slope Efficiency Temperature Variation	$T_A = 0^\circ\text{C to } 70^\circ\text{C}$	$\Delta\eta/\Delta T$		-6000		PPM/ $^\circ\text{C}$	
Peak Wavelength	$I_F=7 \text{ mA}$	$\lambda_p$	830	850	860	Nm	
$\lambda_p$ Temp Coefficient	$I_F=7 \text{ mA}$	$\Delta\lambda_p/\Delta T$		0.06		nm/ $^\circ\text{C}$	
Spectral Bandwidth	$I_F=7 \text{ mA, FWHM}$	$\Delta\lambda$			0.85	nm	
Laser Forward Voltage	$I_F=7 \text{ mA}$	$V_F$		1.8	2.2	V	
Laser Reverse Voltage	$I_R=10 \mu\text{A}$	$BVR_{LD}$		-10		V	
Rise and Fall Time	Bias Above Threshold (20%-80%)	$t_R$ $t_F$			130 150	ps	4
Relative Intensity Noise	1 GHz BW	RIN		-130	-122	dB/Hz	
Series Resistance	$I_F=7 \text{ mA}$	$R_S$	22	35	55	Ohms	
Series Resistance Temperature Coefficient	$I_F=7 \text{ mA, } 0^\circ\text{C to } 70^\circ\text{C}$	$dR_S/dT$		-3000		PPM/ $^\circ\text{C}$	

Photodiode Parameters	Test Condition	Symbol	Min.	Typ.	Max.	Units	Notes
Monitor Current	$P_{OC}=0.5 \text{ mW}$	$I_{PD}$		0.35		mA	
Monitor Current Temperature Variation	$P_{OC}=0.5 \text{ mW}$	$\Delta I_{PD}/\Delta T$		0.2		%/ $^\circ\text{C}$	
Dark Current	$P_o=0 \text{ mW, } V_R=3 \text{ V}$	$I_D$			20	nA	
PD Reverse Voltage	$P_o=0 \text{ mW, } I_R=10 \mu\text{A}$	$BVR_{PD}$	30	115		V	5
PD Capacitance	$V_R=0 \text{ V, Freq}=1 \text{ MHz}$ $V_R=3 \text{ V, Freq}=1 \text{ MHz}$	C		75 40	100 55	pF	

# Fiber Optic Components

## SC Connectorized VCSEL 2.5Gbps

HFE439x-541

### Notes:

1. Operating power is set by the peak operating current  
 $I_{PEAK} = I_{BIAS} + I_{MODULATION}$
2. Operation at temperatures outside the specified range may result in the threshold current exceeding the maximums defined in the electro-optical characteristics table.
3. Slope efficiency is defined as  $\Delta P_o / \Delta I_F$  at a total power output of 0.5 mW. Slope efficiency is intentionally lowered to the values shown by optical attenuation.
4. Rise and fall times are sensitive to drive electronics.
5. To safeguard the VCSEL from current spike damage, short the VCSEL anode and cathode to each other during photodiode BVR verification testing.

www.DataSheet4U.com

### TYPICAL PERFORMANCE CURVES

**Emitted Power vs. Current:** Power varies approximately linearly with current above threshold.

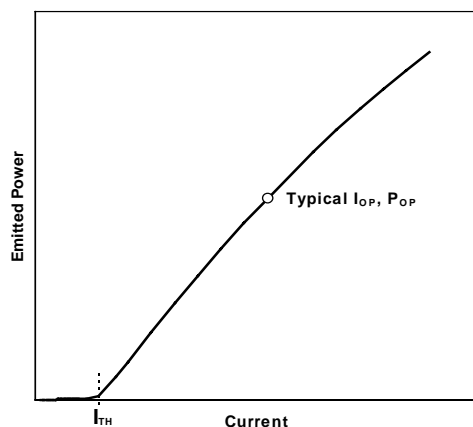

**Emission Intensity vs. Wavelength:** Typical 10 mA spectrum comprises multiple lines corresponding to multiple transverse modes.

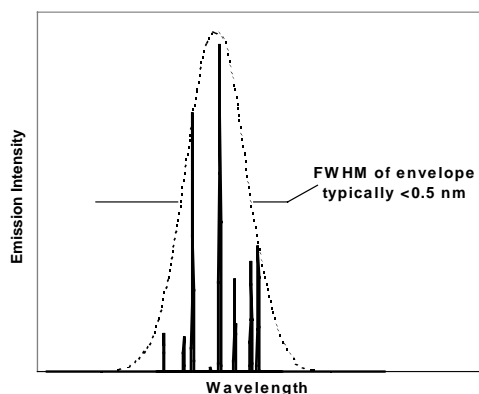

**Threshold Current vs. Temperature:** Threshold current varies parabolically with temperature; thus it can be nearly constant for a limited temperature range.

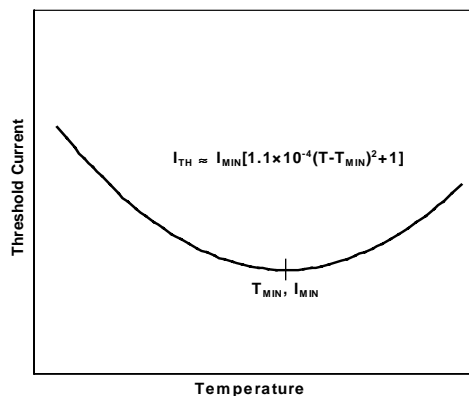

### NOTICE

The inherent design of this component causes it to be sensitive to electrostatic discharge (ESD). To prevent ESD-induced damage and/or degradation to equipment, take normal ESD precautions when handling this product.



The VCSEL is a class IIIb laser and should be treated as a potential eye hazard. Due to the size of the component, the applicable warning logotype, aperture label, and certification/identification label cannot be placed on the component itself. These labels can be found on the individual envelope in which the VCSEL unit is packaged, or attached to the shipping package.

# Fiber Optic LAN Components

## SC Connectorized VCSEL 2.5Gbps

# HFE439x-541

### ORDER GUIDE

Catalog Listing	Description
HFE4390-541	Attenuated VCSEL with Back Monitor Photodiode - VCSEL Anode Common
HFE4391-541	Attenuated VCSEL with Back Monitor Photodiode - VCSEL Cathode Common

### MOUNTING DIMENSIONS (for reference only): in./ (mm)

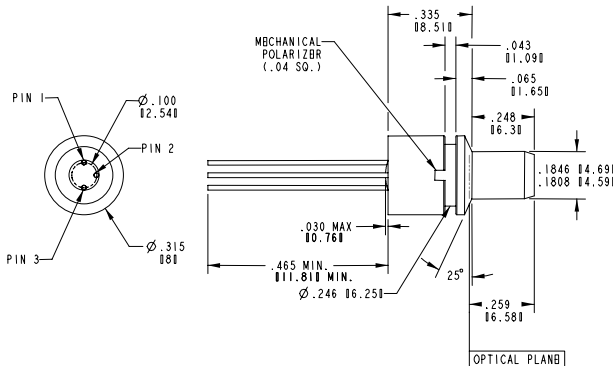

While we provide application assistance, personally and through our literature, it is up to the customer to determine the suitability of the product in the application.

Specifications may change at any time without notice. The information we supply is believed to be accurate and reliable as of this printing. However, we assume no responsibility for its use.

### SALES AND SERVICE

Honeywell Sensing and Control serves its customers through a worldwide network of sales offices and distributors. For application assistance, current specifications, pricing or name of the nearest Authorized Distributor, contact a nearby sales office or call:

### TELEPHONE

1-800-367-6786 (USA)  
 1-800-737-3360 (Canada)  
 +49 (0) 89 35813310 (Germany)  
 +65-580-3312 (Singapore)  
 +44 (0) 118 981 9511 (UK)

### PINOUT

HFE4390-541		HFE4391-541	
Number	Function	Number	Function
1	K <sub>LD</sub>	1	A <sub>LD</sub>
2	K <sub>PD</sub> , A <sub>LD</sub>	2	K <sub>LD</sub> , A <sub>PD</sub>
3	A <sub>PD</sub>	3	K <sub>PD</sub>

### PINOUT DEFINITIONS

A <sub>LD</sub>	VCSEL Anode	A <sub>PD</sub>	Monitor Photodiode Anode
K <sub>LD</sub>	VCSEL Cathode	K <sub>PD</sub>	Monitor Photodiode Cathode

### FAX

1-972-470-4326 (Customer Response Center)  
 1-972-470-4549 (Fax on demand)  
 +49 (0) 89 3599971 (Germany)  
 +65 445 3033 (Singapore)  
 +44 (0) 118 981 7513 (UK)

### INTERNET

<http://www.honeywell.com/VCSEL>  
 VCSEL@honeywell.com

### WARRANTY/REMEDY

Honeywell warrants goods of its manufacture as being free of defective materials and faulty workmanship. Commencing with the date of shipment, Honeywell's warranty runs for 18 months. If warranted goods are returned to Honeywell during that period of coverage, Honeywell will repair or replace without charge those items it finds defective. The foregoing is Buyer's sole remedy and is **in lieu of all other warranties, expressed or implied, including those of merchantability and fitness for a particular purpose.**

01/29/02

# Honeywell

Honeywell Inc.  
 11 West Spring Street  
 Freeport, Illinois 61032



Honeywell Inc.  
 Optoelectronics Facility  
 830 East Arapaho Road  
 Richardson, Texas 75081

**Honeywell Control Systems Ltd.**  
 Zodiac House  
 Calleva Park  
 Aldermaston, Berkshire  
 RG7 8HW England

*Helping You Control Your World*

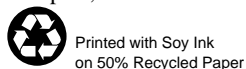

006694-1-EN IL50 GLO 797 Printed in USA

[www.DataSheet4U.com](http://www.DataSheet4U.com)

## Fiber Optic LAN Components LC SFF Duplex OFE 2.5 Gbps

# HFT219x-521

### FEATURES

- Prealigned Fixed LC Duplex Optical Front End (OFE)
- VCSEL packaged with a back monitor photodiode
- Common anode and common cathode polarities available
- TO-46 hermetic package for VCSEL and Pin + Preamp
- 3.3 V operation
- GaAs PIN detector and BiCMOS preamplifier
- Differential output for low noise
- High Speed >1GHz
- Laser signal is attenuated
- Unattenuated versions available as well (HFT2193-522 and HFT2194-522)

LASER RADIATION  
AVOID EXPOSURE TO BEAM  
CLASS 3B LASER PRODUCT

INVISIBLE LASER RADIATION  
AVOID EXPOSURE TO BEAM  
5 mW AT 820-850 nm  
CLASS 3B LASER PRODUCT  
PER IEC/EN 60825-1A:1995  
AND 21 CFR 1040

Honeywell  
830 East Arapaho Road  
Richardson, TX 75081



SEMICONDUCTOR LASER



AVOID EXPOSURE: Invisible LASER radiation is emitted from this aperture



The HFT219x-52x is a single package transmitter and receiver designed to interface with the LC style optical connectors.

The transmitter is a high performance 850nm VCSEL (Vertical Cavity Surface Emitting Laser) packaged for high speed data communications. This product combines all the performance advantages of VCSEL with a custom designed power monitor diode. The power monitor diode can be used with an appropriate feedback control circuitry to set a maximum power level for each VCSEL. Attenuating coatings are available on the Laser transmitter to simplify design and assist in meeting eye safety requirements.

The PIN + preamp converts optical power into a differential output electrical signal. As the light increases, the differential output voltage increases, limiting at input powers above -10dBm. The differential output is designed to be AC coupled into a data amplifier.

The Honeywell HFT219x-521 is designed to interface with 50/125 and 62.5/125µm multimode fiber within an LC style interface.

# Fiber Optic LAN Components

## LC SFF Duplex OFE 2.5 Gbps

# HFT219x-521

### VCSEL PARAMETERS

#### ELECTRO-OPTICAL CHARACTERISTICS (T<sub>A</sub>=25°C unless otherwise stated)

VCSEL Parameters	Test Condition	Symbol	Min.	Typ.	Max.	Units	Notes
Peak Fiber Coupled Optical Power (See threshold current and slope efficiency which control power output)	I <sub>F</sub> =9 mA Peak 50/125 μm fiber NA=0.20	P <sub>OC</sub>		350		μW	1
Threshold Current		I <sub>TH</sub>	1	3	5	mA	
Threshold Current Temperature Variation	T <sub>A</sub> = 0°C to 70°C	Δ I <sub>TH</sub>	-1.5		1.5	mA	2
Slope Efficiency	P <sub>OC</sub> =0.5 mW	η	0.028		0.14	mW/mA	3
Slope Efficiency Temperature Variation	T <sub>A</sub> = 0°C to 70°C	Δη/ΔT		-6000		PPM/°C	
Peak Wavelength	I <sub>F</sub> =9 mA	λ <sub>P</sub>	830	850	860	nm	
λ <sub>P</sub> Temp Coefficient	I <sub>F</sub> =9 mA	Δλ <sub>P</sub> /ΔT		0.06		nm/°C	
Spectral Bandwidth	I <sub>F</sub> =9 mA, FWHM	Δλ			0.85	nm	
Laser Forward Voltage	I <sub>F</sub> =9 mA	V <sub>F</sub>		1.8	2.2	V	
Laser Reverse Voltage	I <sub>R</sub> =10 μA	BVR <sub>LD</sub>		-10		V	
Rise and Fall Time	Bias Above Threshold (20%-80%)	t <sub>R</sub> t <sub>F</sub>			130 150	ps	4
Relative Intensity Noise	1 GHz BW	RIN		-130	-122	dB/Hz	
Series Resistance	I <sub>F</sub> =9 mA	R <sub>S</sub>	18	25	40	Ohms	
Series Resistance Temperature Coefficient	I <sub>F</sub> =9 mA, 0°C to 70°C	dR <sub>S</sub> /dT		-3000		PPM/°C	

Photodiode Parameters	Test Condition	Symbol	Min.	Typ.	Max.	Units	Notes
Monitor Current	P <sub>OC</sub> =0.5 mW	I <sub>PD</sub>		0.42		mA	
Monitor Current Temperature Variation	P <sub>OC</sub> =0.5 mW	ΔI <sub>PD</sub> /ΔT		0.2		%/°C	
Dark Current	P <sub>O</sub> =0 mW, V <sub>R</sub> =3 V	I <sub>D</sub>			20	nA	
PD Reverse Voltage	P <sub>O</sub> =0 mW, I <sub>R</sub> =10 μA	BVR <sub>PD</sub>	30	115		V	5
PD Capacitance	V <sub>R</sub> =0 V, Freq=1 MHz V <sub>R</sub> =3 V, Freq=1 MHz	C		75 40	100 55	pF	

#### Notes:

- Operating power is set by the peak operating current I<sub>PEAK</sub>=I<sub>BIAS</sub>+I<sub>MODULATION</sub>.
- Operation at temperatures outside the specified range may result in the threshold current exceeding the maximums defined in the electro-optical characteristics table.
- Slope efficiency is defined as ΔP<sub>O</sub>/ΔI<sub>F</sub> at a total power output of 0.5 mW. Slope efficiency is intentionally lowered to the values shown by optical attenuation.
- Rise and fall times are sensitive to drive electronics.
- To safeguard the VCSEL from current spike damage, short the VCSEL anode and cathode to each other during photodiode BVR verification testing. Additionally to safeguard the PIN photodiode, limit the photodiode reverse voltage in accordance with the absolute maximum rating

# Fiber Optic LAN Components

## LC SFF Duplex OFE 2.5 Gbps

# HFT219x-521

### RECEIVER PARAMETERS

#### **ELECTRO-OPTICAL CHARACTERISTICS** ( $V_{cc}=3.3V$ , AC coupled to $50\Omega$ , $0^{\circ}C < T < 70^{\circ}C$ unless otherwise specified)

Parameters	Test Condition	Symbol	Min.	Typ.	Max.	Units	Notes
<b>Electrical Characteristics</b>							
Supply Voltage	$P_{in} = 0\mu W$ , $R_{load}=50\Omega$	$V_{cc}$	3.0	3.3	3.8	Volts	1
Supply Current	$P_{in} = 0\mu W$ , $R_{load}=50\Omega$	$I_{cc}$		26	50	mA	1
Output Voltage	$P_{in} = 100\mu W$ , $R_{load}=50\Omega$	$V_{out}$		200	500	mV	1
<b>Opto-Electronic Characteristics</b>							
Responsivity	$P_{in} = 20\mu W$ peak, $R_{load}=50\Omega$	R		1600		$\mu V/\mu W$	2,3
Upper 3dB Bandwidth		$BW_{upper}$	2000	2400	2800	MHz	4
RMS Output Referred Noise	$P_{in}=0\mu W$ , $R_{load}=50\Omega$ 1875 MHz BT Filter			500		nW	5
Sensitivity	$BER=10^{-12}$ , $SNR=7$	S	-20	-24		dBm	
Power Supply Rejection Ratio	$P_{in}=0\mu W$ , $R_{load}=50\Omega$	PSRR	10	30		dB	6
Pulse Width Distortion	$P_{in}=20\mu W$ peak, $R_{load}=50\Omega$	PWD			40	ps	7
Rise/Fall Time	$P_{in}=20\mu W$ peak, $R_{load}=50\Omega$	$T_R/T_F$			250	ps	8
Wavelength Responsivity	$P_{in}=20\mu W$ peak, $R_{load}=50\Omega$	$\lambda$	760	850	860	nm	

#### **Notes:**

1. Pin refers to the total optical power at the face of the fiber optic cable input.
2. Responsivity measured with source wavelength of 850nm, 125MHz square wave,  $P_{in}=20\mu W$  peak,  $R_{load}=50\Omega$ .
3. The output voltage increases as received light power increases, up to approximately -15dBm. The preamplifier is designed to limit the electrical output signal above this optical input level, and does not introduce signal distortion until the average input power exceeds 0dBm.
4. Bandwidth is measured with a small signal sinusoidal light source with  $50\mu W$  average power,  $R_{load}=50\Omega$ .
5. RMS input referred optical noise is obtained by measuring the RMS output referred noise, then dividing by the responsivity.
6. PSRR is measured from 300KHz to 1GHz by injecting a -20dB electrical signal on the  $V_{cc}$  pin. The nominal value at 100MHz is recorded. No external bypass components are assumed. An external  $V_{cc}$  filter network will greatly increase the PSRR.
7. Measured at the 50% level of output pulses using 0.5 GHz square wave with <200 ps rise time.
8. Rise and fall times are measured with source wavelength of 850nm, 125MHz square wave, with optical rise and fall times < 200ps,  $P_{in}=20\mu W$  peak,  $R_{load}=50\Omega$ .

# Fiber Optic LAN Components LC SFF Duplex OFE 2.5 Gbps

# HFT219x-521

## Absolute Maximum Ratings

Parameter	Rating
Storage Temperature	-40 to +85°C
Operating Temperature	0 to +70°C
Lead Solder Temperature	260°C, 10 sec.
Continuous Optical Output Power (Any Current)	5 mW
Laser Diode Reverse Voltage ( $I_R=10 \mu A$ )	5 V
Laser Continuous Forward Current, Heat-Sinked	15 mA
PIN Photodiode Forward Current	10 mA
Power Supply Voltage (PIN + Preamp)	3.8 V
Incident Optical Power	0 dBm average, +4 dBm peak

### **NOTICE**

Stresses greater than those listed under “Absolute Maximum Ratings” may cause permanent damage to the device. This is a stress rating only and functional operation of the device at these or any other conditions above those indicated in the operations section for extended periods of time may affect reliability.

### **NOTICE**

The inherent design of this component causes it to be sensitive to electrostatic discharge (ESD). To prevent ESD-induced damage and/or degradation to equipment, take normal ESD precautions when handling this product

## ORDER GUIDE

Catalog Listing	Description
HFT2190-521	Attenuated, Common Anode
HFT2191-521	Attenuated, Common Cathode



# Fiber Optic LAN Components

## LC SFF Duplex OFE 2.5 Gbps

# HFT219x-521

### TYPICAL PERFORMANCE CURVES

**Emitted Power vs. Current:** Power varies approximately linearly with current above threshold.

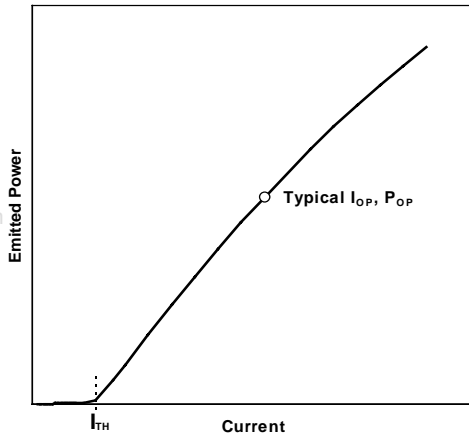

**Emission Intensity vs. Wavelength:** Typical 10 mA spectrum comprises multiple lines corresponding to multiple transverse modes.

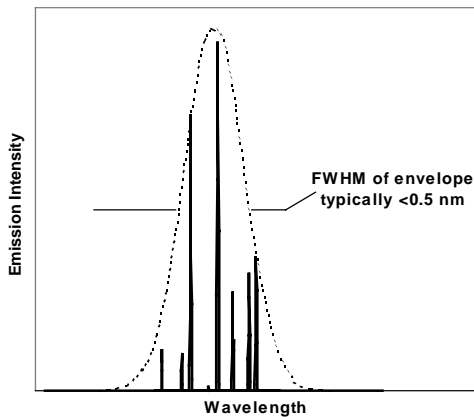

**Threshold Current vs. Temperature:** Threshold current varies parabolically with temperature; thus it can be nearly constant for a limited temperature range.

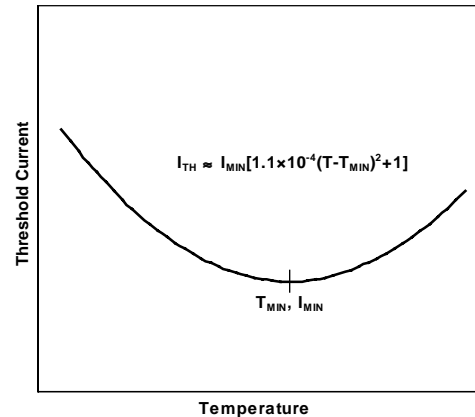

### NOTICE

The inherent design of this component causes it to be sensitive to electrostatic discharge (ESD). To prevent ESD-induced damage and/or degradation to equipment, take normal ESD precautions when handling this product.

### DANGER

The VCSEL is a class IIIb laser and should be treated as a potential eye hazard. Due to the size of the component, the applicable warning logotype, aperture label, and certification/identification label cannot be placed on the component itself. These labels can be found on the individual envelope in which the VCSEL unit is packaged, or attached to the shipping package.

# Fiber Optic LAN Components

## LC SFF Duplex OFE 2.5 Gbps

*HFT219x-521*

FIGURE 1: INTERNAL SCHEMATIC DIAGRAM OF THE HFD3180-102

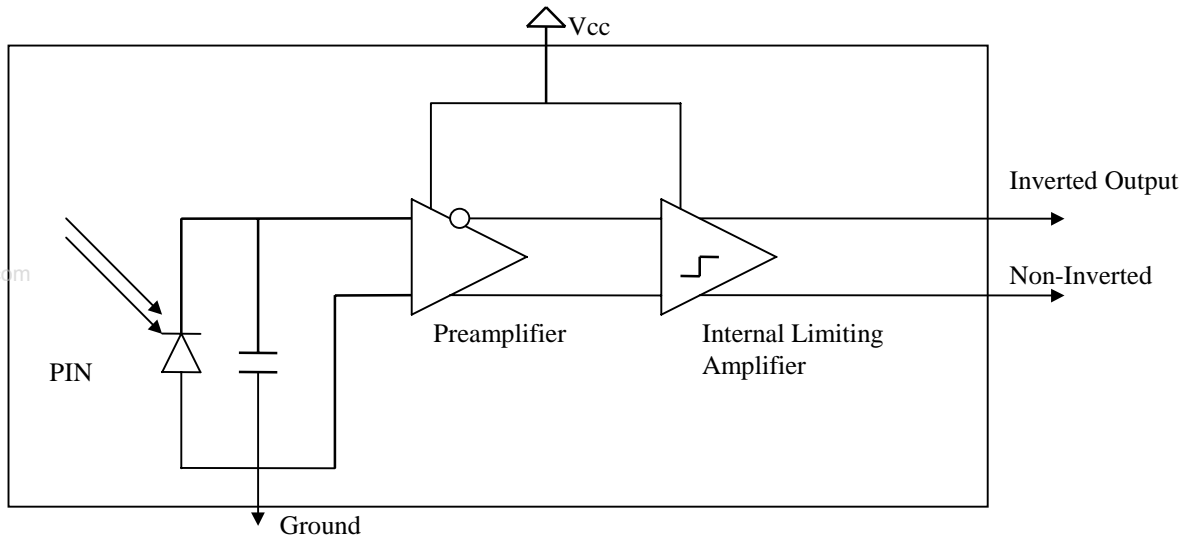
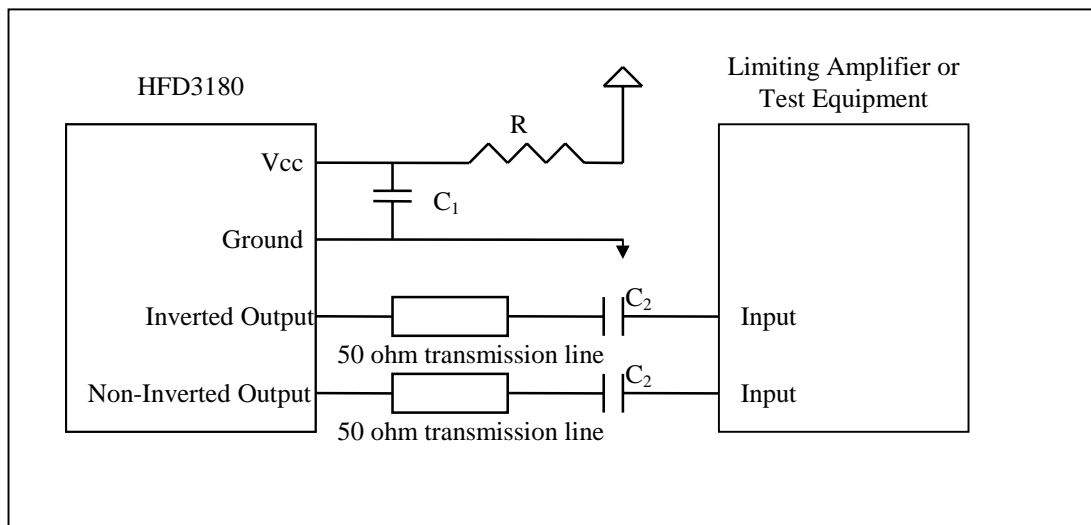

FIGURE 2: RECOMMENDED INTERFACE CIRCUIT FOR THE HFD3180-102



$R = 10 \Omega$

$C_1 = 10 \text{ nF}$

$C_2 = \text{DATA RATE DEPENDANT (22NF FOR RATES > 1GB)}$

# Fiber Optic LAN Components

## LC SFF Duplex OFE 2.5 Gbps

# HFT219x-521

www.DataSheet4U.com

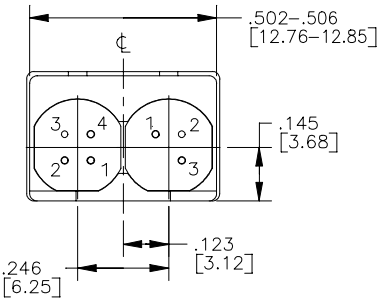
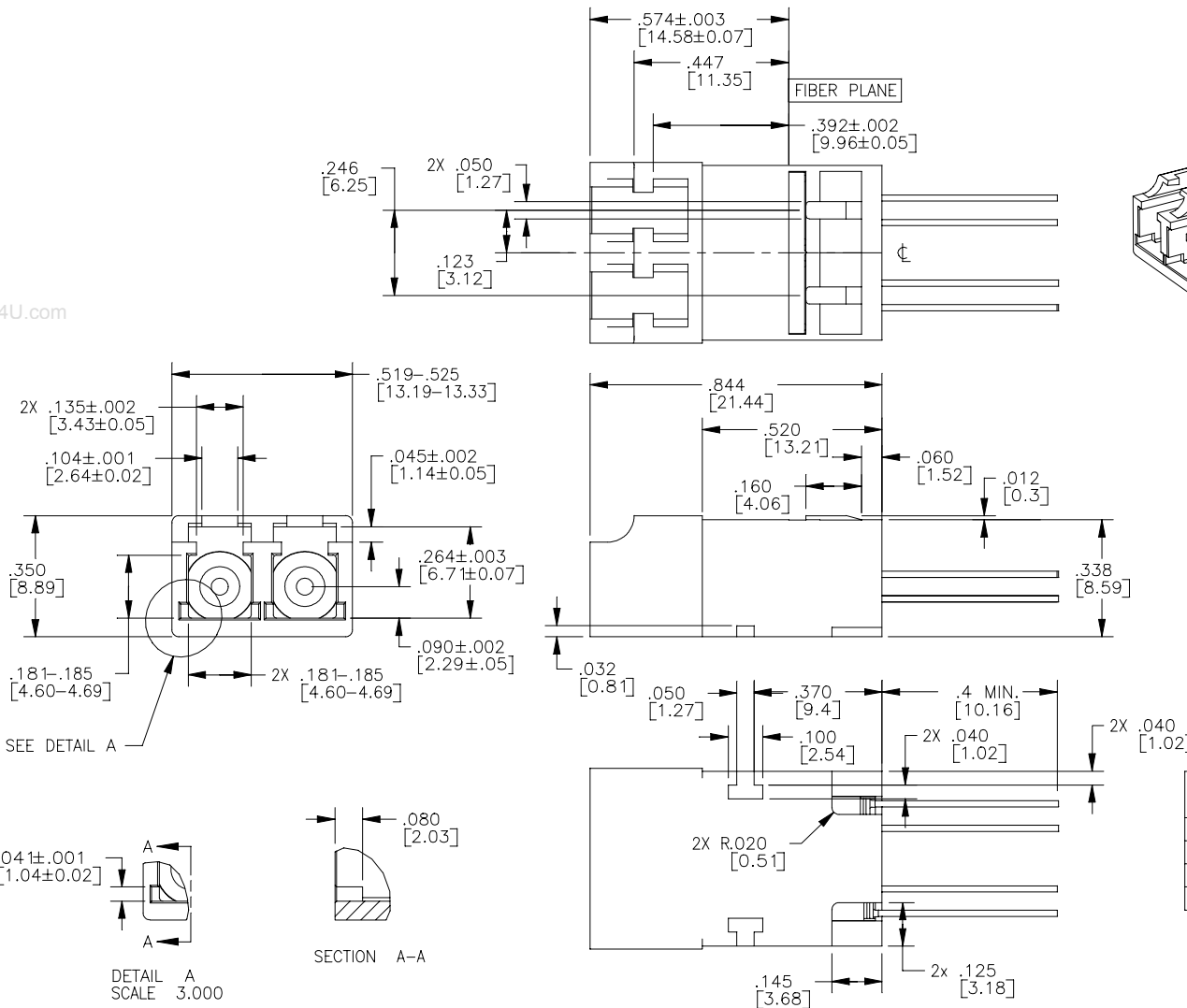
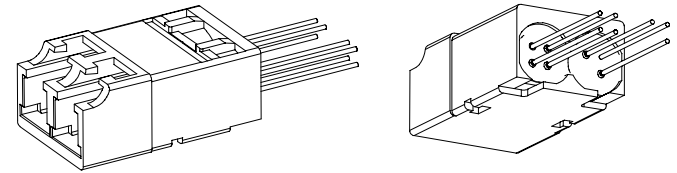

PIN #	RCVR	XMTR	
		HFT2180/HFT2190	HFT2181/HFT2191
1	Vcc	VCSEL CATH.	VCSEL ANODE
2	OUT-	VCSEL ANODE & PD CATH.	VCSEL CATH. & PD ANODE
3	GND	PD ANODE	PD CATHODE
4	OUT+	N/A	N/A

# Fiber Optic LAN Components

## LC SFF Duplex OFE 2.5 Gbps

# HFT2 19x-521

### WARRANTY/REMEDY

Honeywell warrants goods of its manufacture as being free of defective materials and faulty workmanship. Commencing with the date of shipment, Honeywell's warranty runs for 18 months. If warranted goods are returned to Honeywell during that period of coverage, Honeywell will repair or replace without charge those items it finds defective. The foregoing is Buyer's sole remedy and is **in lieu of all other warranties, expressed or implied, including those of merchantability and fitness for a particular purpose.**

While we provide application assistance, personally and through our literature, it is up to the customer to determine the suitability of the product in the application.

Specifications may change at any time without notice. The information we supply is believed to be accurate and reliable as of this printing. However, we assume no responsibility for its use.

### SALES AND SERVICE

Honeywell Sensing and Control serves its customers through a worldwide network of sales offices and distributors. For application assistance, current specifications, pricing or name of the nearest Authorized Distributor, contact a nearby sales office or call:

#### TELEPHONE

1-800-367-6786 (USA)  
1-800-737-3360 (Canada)  
+49 (0) 89 35813310 (Germany)  
+65-580-3312 (Singapore)  
+44 (0) 118 981 9511 (UK)

#### INTERNET

<http://www.honeywell.com/sensing/VCSEL>  
[info.sc@honeywell.com](mailto:info.sc@honeywell.com)

#### FAX

1-972-470-4326 (Customer Response Center)  
1-972-470-4549 (Fax on demand)  
+49 (0) 89 3599971 (Germany)  
+65 445 3033 (Singapore)  
+44 (0) 118 981 7513 (UK)

7/23/01

## Honeywell

Honeywell Inc.  
11 West Spring Street  
Freeport, Illinois 61032

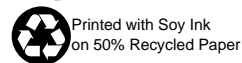

PK XXXX X DMM Printed in USA



Honeywell Inc.  
Optoelectronics Facility  
830 East Arapaho Road  
Richardson, Texas 75081

**Honeywell Control  
Systems Ltd.**  
Zodiac House  
Calleva Park  
Aldermaston, Berkshire  
RG7 8HW England

*Helping You Control Your World*

[www.DataSheet4U.com](http://www.DataSheet4U.com)

## Fiber Optic LAN Components LC SFF Duplex OFE 2.5 Gbps

# HFT219x-541

### FEATURES

- Prealigned Fixed LC Duplex Optical Front End (OFE)
- VCSEL packaged with a back monitor photodiode
- Common anode and common cathode polarities available
- TO-46 hermetic package for VCSEL and Pin + Preamp
- 3.3 V operation
- GaAs PIN detector and BiCMOS preamplifier
- Differential output for low noise
- High Speed >1GHz
- Laser signal is attenuated

LASER RADIATION  
AVOID EXPOSURE TO BEAM  
CLASS 3B LASER PRODUCT

INVISIBLE LASER RADIATION  
AVOID EXPOSURE TO BEAM  
5 mW AT 820-850 nm  
CLASS 3B LASER PRODUCT  
PER IEC/EN 60825-1A:1995  
AND 21 CFR 1040

Honeywell  
830 East Arapaho Road  
Richardson, TX 75081

SEMICONDUCTOR LASER

AVOID EXPOSURE: Invisible LASER radiation is emitted from this aperture



The HFT219x-541 is a single package transmitter and receiver designed to interface with the LC style optical connectors.

The transmitter is a high performance 850nm VCSEL (Vertical Cavity Surface Emitting Laser) packaged for high speed data communications. This product combines all the performance advantages of VCSEL with a custom designed power monitor diode. The power monitor diode can be used with an appropriate feedback control circuitry to set a maximum power level for each VCSEL. Attenuating coatings are available on the Laser transmitter to simplify design and assist in meeting eye safety requirements.

The PIN + preamp converts optical power into a differential output electrical signal. As the light increases, the differential output voltage increases, limiting at input powers above -10dBm. The differential output is designed to be AC coupled into a data amplifier.

The Honeywell HFT219x-541 is designed to interface with 50/125 and 62.5/125µm multimode fiber within an LC style interface.

# Fiber Optic LAN Components

## LC SFF Duplex OFE 2.5 Gbps

# HFT219x-541

### VCSEL PARAMETERS

VCSEL Parameters	Test Condition	Symbol	Min.	Typ.	Max.	Units	Notes
Peak Fiber Coupled Optical Power (See threshold current and slope efficiency which control power output)	$I_F=7$ mA av. 50/125 $\mu$ m fiber NA=0.20	$P_{OC}$		500		$\mu$ W	1
Threshold Current		$I_{TH}$	1	2	3	mA	
Threshold Current Temperature Variation	$T_A = 0^\circ\text{C}$ to $70^\circ\text{C}$	$\Delta I_{TH}$	-1.5		1.5	mA	2
Slope Efficiency		$\eta$	0.04		0.16	mW/mA	3
Slope Efficiency Temperature Variation	$T_A = 0^\circ\text{C}$ to $70^\circ\text{C}$	$\Delta\eta/\Delta T$		-6000		PPM/ $^\circ\text{C}$	
Peak Wavelength	$I_F=7$ mA	$\lambda_P$	830	850	860	Nm	
$\lambda_P$ Temp Coefficient	$I_F=7$ mA	$\Delta\lambda_P/\Delta T$		0.06		nm/ $^\circ\text{C}$	
Spectral Bandwidth	$I_F=7$ mA, FWHM	$\Delta\lambda$			0.85	nm	
Laser Forward Voltage	$I_F=7$ mA	$V_F$		1.8	2.2	V	
Laser Reverse Voltage	$I_R=10$ $\mu$ A	$BVR_{LD}$		-10		V	
Rise and Fall Time	Bias Above Threshold (20%-80%)	$t_R$ $t_F$			130 150	ps	4
Relative Intensity Noise	1 GHz BW	RIN		-130	-122	dB/Hz	
Series Resistance	$I_F=7$ mA	$R_S$	22	35	55	Ohms	
Series Resistance Temperature Coefficient	$I_F=7$ mA, $0^\circ\text{C}$ to $70^\circ\text{C}$	$dR_S/dT$		-3000		PPM/ $^\circ\text{C}$	

Photodiode Parameters	Test Condition	Symbol	Min.	Typ.	Max.	Units	Notes
Monitor Current	$P_{OC}=0.5$ mW	$I_{PD}$		0.35		mA	
Monitor Current Temperature Variation	$P_{OC}=0.5$ mW	$\Delta I_{PD}/\Delta T$		0.2		%/ $^\circ\text{C}$	
Dark Current	$P_O=0$ mW, $V_R=3$ V	$I_D$			20	nA	
PD Reverse Voltage	$P_O=0$ mW, $I_R=10$ $\mu$ A	$BVR_{PD}$	30	115		V	5
PD Capacitance	$V_R=0$ V, Freq=1 MHz $V_R=3$ V, Freq=1 MHz	C		75 40	100 55	pF	

### Notes:

- Operating power is set by the peak operating current  $I_{PEAK}=I_{BIAS}+I_{MODULATION}$ .
- Operation at temperatures outside the specified range may result in the threshold current exceeding the maximums defined in the electro-optical characteristics table.
- Slope efficiency is defined as  $\Delta P_O/\Delta I_F$  at a total power output of 0.5 mW. Slope efficiency is intentionally lowered to the values shown by optical attenuation.
- Rise and fall times are sensitive to drive electronics.
- To safeguard the VCSEL from current spike damage, short the VCSEL anode and cathode to each other during photodiode BVR verification testing.

# Fiber Optic LAN Components

## LC SFF Duplex OFE 2.5 Gbps

# HFT219x-541

### RECEIVER PARAMETERS

**ELECTRO-OPTICAL CHARACTERISTICS** ( $V_{cc}=3.3V$ , AC coupled to  $50\Omega$ ,  $0^{\circ}C < T < 70^{\circ}C$  unless otherwise specified)

Parameters	Test Condition	Symbol	Min.	Typ.	Max.	Units	Notes
<b>Electrical Characteristics</b>							
Supply Voltage	$P_{in} = 0\mu W$ , $R_{load}=50\Omega$	$V_{cc}$	3.0	3.3	3.6	Volts	1
Supply Current	$P_{in} = 0\mu W$ , $R_{load}=50\Omega$	$I_{cc}$		26	40	mA	1
Output Offset Voltage	$P_{in} = 0\mu W$ , $R_{load}=50\Omega$	$V_{offset}$	-100		100	mV	9,10
Output Resistance	Single ended, freq = 0Hz	$R_o$	40	50	62	$\Omega$	
<b>Opto-Electronic Characteristics</b>							
Responsivity	$P_{in} < AGC_{th}$ , $R_{load}=50\Omega$	R		1400		$\mu V/\mu W$	2,3,10
Differential Output Voltage	$P_{in} = 200\mu W$ , $R_{load}=50\Omega$ , $V_{offset} = 0$ mV	$V_{out}$	90	160	400	mV	1
Upper 3dB Bandwidth		$BW_{upper}$	1700	1900	2500	MHz	4
RMS Output Referred Noise	$P_{in}=0\mu W$ , $R_{load}=50\Omega$ 1875 MHz BT Filter			1.5	2.25	mV	5
Sensitivity	$BER=10^{-12}$ , $SNR=7$	S	-17	-20		dBm	
Power Supply Rejection Ratio	$P_{in}=0\mu W$ , $R_{load}=50\Omega$	PSRR	10	30		dB	6
Pulse Width Distortion	$P_{in}=20\mu W$ peak, $R_{load}=50\Omega$	PWD			40	ps	7
Rise/Fall Time	$P_{in}=20\mu W$ peak, $R_{load}=50\Omega$	$T_R/T_F$			250	ps	8
Wavelength Responsivity	$P_{in}=20\mu W$ peak, $R_{load}=50\Omega$	$\lambda$	760	850	860	nm	
AGC <sub>th</sub> threshold power	$V_{offset} = 0$ mV, $P_{in} =$ Peak power	AGC <sub>th</sub>		60		$\mu W$	9,10

#### Notes:

- Pin refers to the peak optical power at the face of the fiber optic cable input to the HFD3180-102.
- Responsivity measured with source wavelength of 850nm, freq = 0Hz,  $P_{in} < AGC_{th}$ ,  $R_{load}=50\Omega$ , sample tested at 2.5Gbps
- The output voltage increases as received light power increases, up to approximately -15dBm depending upon the AGC<sub>th</sub>. The preamplifier is designed to limit the electrical output signal above this optical input level, and does not introduce signal distortion until the average input power exceeds 0dBm.
- Bandwidth is measured with a small signal sinusoidal light source with 50  $\mu W$  average power,  $R_{load}=50\Omega$ .
- RMS input referred optical noise is sample tested by measuring the RMS output referred noise, then dividing by the responsivity.
- PSRR is sample tested from 300KHz to 1GHz by injecting a -20dB electrical signal on the  $V_{cc}$  pin. The nominal value at 100MHz is recorded. No external bypass components are assumed. An external  $V_{cc}$  filter network will greatly increase the PSRR.
- Sample tested at the 50% level of output pulses.
- Rise and fall times are sample tested with source wavelength of 850nm, 125MHz square wave, with optical rise and fall times < 200ps,  $P_{in} < AGC_{th}$ ,  $R_{load}=50\Omega$ . Measured at 20% - 80% signal levels
- Output offset voltage is defined as  $V_{out} - V_{outQ}$  with no light
- The AGC<sub>th</sub> power depends on the offset voltage. Refer to fig 3.

# Fiber Optic LAN Components LC SFF Duplex OFE 2.5 Gbps

# HFT219x-541

## Absolute Maximum Ratings

Parameter	Rating
Storage Temperature	-40 to +85°C
Operating Temperature	0 to +70°C
Lead Solder Temperature	260°C, 10 sec.
Continuous Optical Output Power (Any Current)	5 mW
Laser Diode Reverse Voltage ( $I_R=10 \mu A$ )	5 V
Laser Continuous Forward Current, Heat-Sinked	12 mA
PIN Photodiode Forward Current	10 mA
Power Supply Voltage (PIN + Preamp)	3.8 V
Incident Optical Power	0 dBm average, +4 dBm peak

### **NOTICE**

Stresses greater than those listed under “Absolute Maximum Ratings” may cause permanent damage to the device. This is a stress rating only and functional operation of the device at these or any other conditions above those indicated in the operations section for extended periods of time may affect reliability.

### **NOTICE**

The inherent design of this component causes it to be sensitive to electrostatic discharge (ESD). To prevent ESD-induced damage and/or degradation to equipment, take normal ESD precautions when handling this product

## ORDER GUIDE

Catalog Listing	Description
HFT2190-541	Attenuated, Common Anode
HFT2191-541	Attenuated, Common Cathode



# Fiber Optic LAN Components

## LC SFF Duplex OFE 2.5 Gbps

# HFT219x-541

### TYPICAL PERFORMANCE CURVES

**Emitted Power vs. Current:** Power varies approximately linearly with current above threshold.

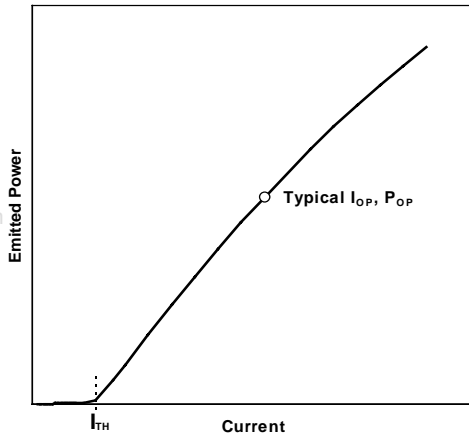

**Emission Intensity vs. Wavelength:** Typical 10 mA spectrum comprises multiple lines corresponding to multiple transverse modes.

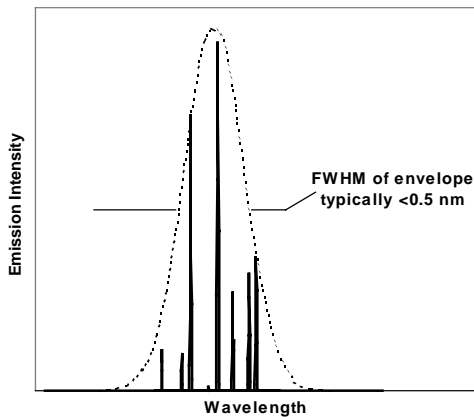

**Threshold Current vs. Temperature:** Threshold current varies parabolically with temperature; thus it can be nearly constant for a limited temperature range.

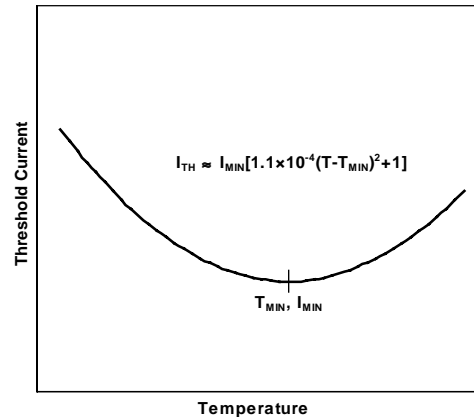

### NOTICE

The inherent design of this component causes it to be sensitive to electrostatic discharge (ESD). To prevent ESD-induced damage and/or degradation to equipment, take normal ESD precautions when handling this product.

### DANGER

The VCSEL is a class IIIb laser and should be treated as a potential eye hazard. Due to the size of the component, the applicable warning logotype, aperture label, and certification/identification label cannot be placed on the component itself. These labels can be found on the individual envelope in which the VCSEL unit is packaged, or attached to the shipping package.

# Fiber Optic LAN Components LC SFF Duplex OFE 2.5 Gbps

# HFT219x-541

**FIGURE 1: INTERNAL SCHEMATIC DIAGRAM OF THE HFD3180-102**

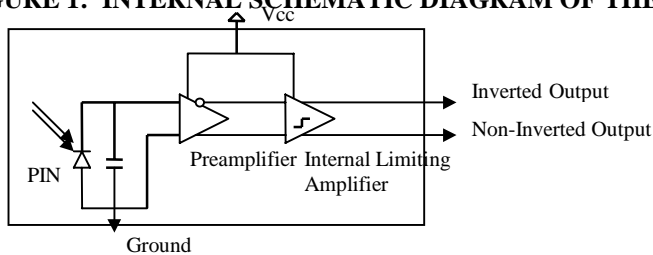

www.DataSheet4U.com

**FIGURE 2: RECOMMENDED INTERFACE CIRCUIT FOR THE HFD3180-102**

$R=10\ \Omega$

$C_1 = 10\ \text{nF}$

$C_2 = \text{Data rate dependant (22nF for rates } > 1\text{Gbps)}$

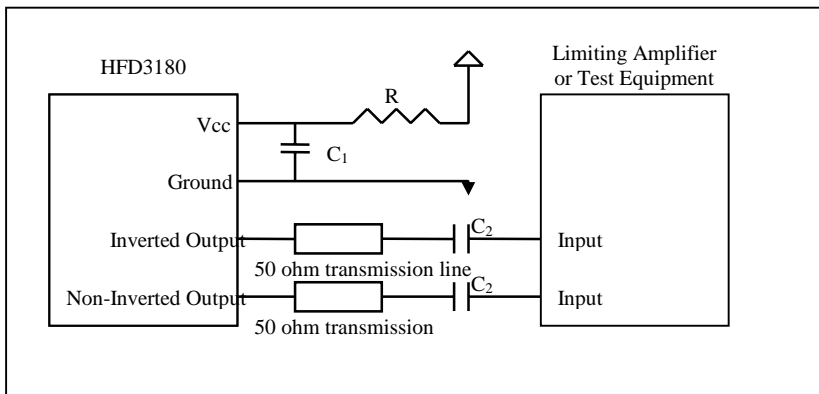

**FIGURE 3: AGC THRESHOLD POWER VS. OUTPUT OFFSET VOLTAGE**

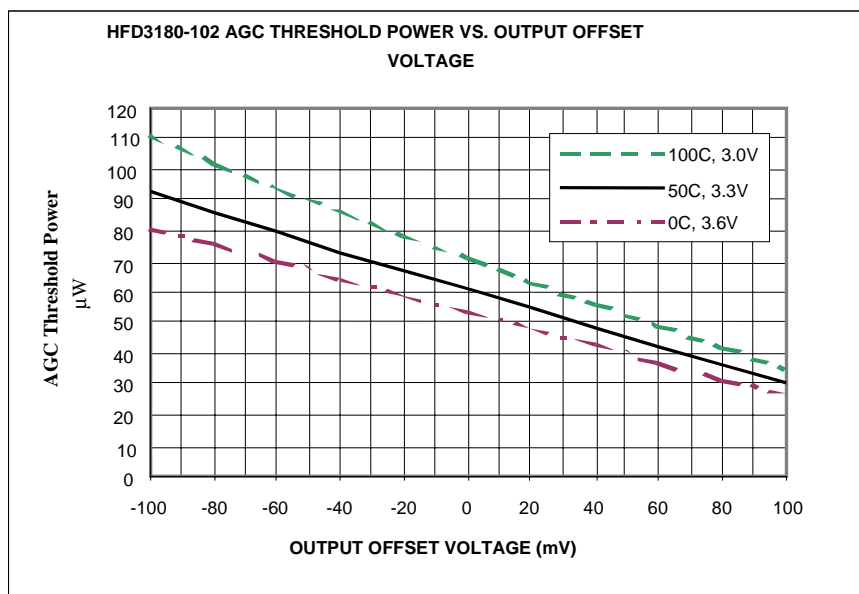

# Fiber Optic LAN Components

## LC SFF Duplex OFE 2.5 Gbps

# HFT219x-541

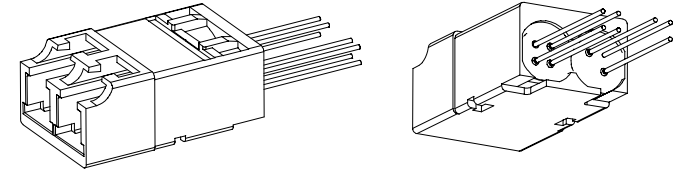
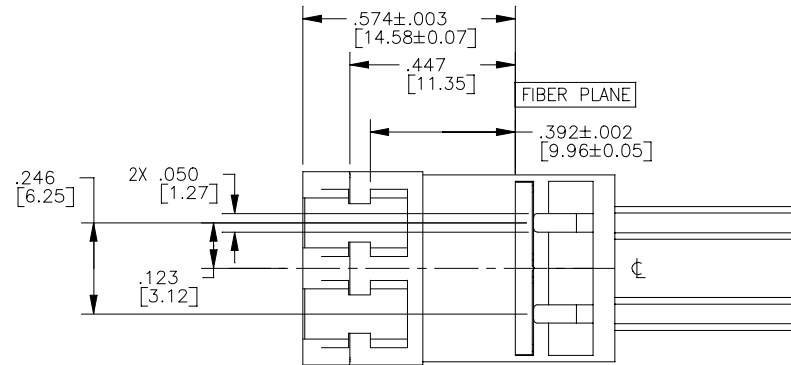

www.DataSheet4U.com

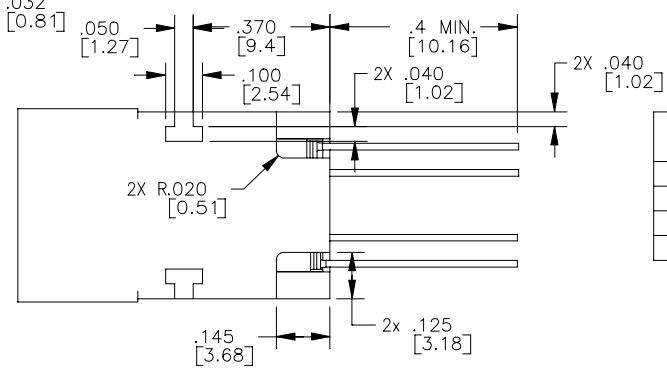
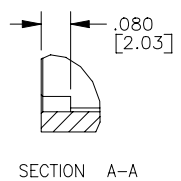
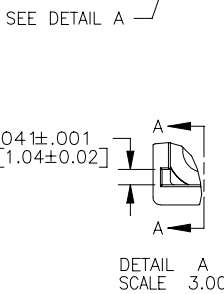
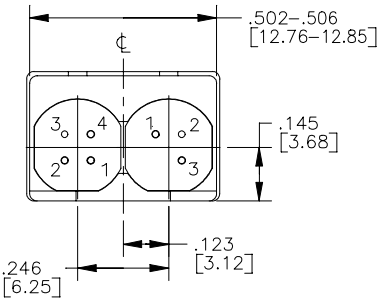
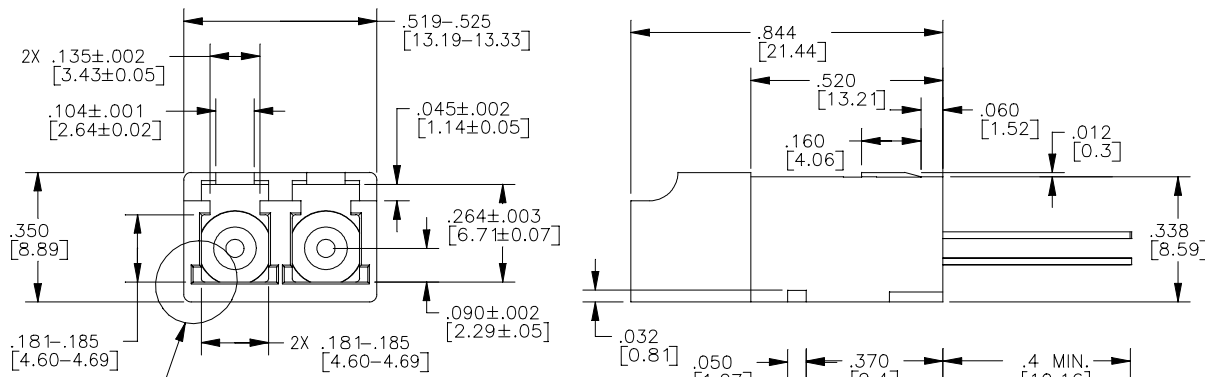

PIN #	RCVR	XMTR	
		HFT2180/HFT2190	HFT2181/HFT2191
1	Vcc	VCSEL CATH.	VCSEL ANODE
2	OUT-	VCSEL ANODE & PD CATH.	VCSEL CATH. & PD ANODE
3	GND	PD ANODE	PD CATHODE
4	OUT+	N/A	N/A

# Fiber Optic LAN Components

## LC SFF Duplex OFE 2.5 Gbps

# HFT219x-541

### WARRANTY/REMEDY

Honeywell warrants goods of its manufacture as being free of defective materials and faulty workmanship. Commencing with the date of shipment, Honeywell's warranty runs for 18 months. If warranted goods are returned to Honeywell during that period of coverage, Honeywell will repair or replace without charge those items it finds defective. The foregoing is Buyer's sole remedy and is **in lieu of all other warranties, expressed or implied, including those of merchantability and fitness for a particular purpose.**

While we provide application assistance, personally and through our literature, it is up to the customer to determine the suitability of the product in the application.

Specifications may change at any time without notice. The information we supply is believed to be accurate and reliable as of this printing. However, we assume no responsibility for its use.

### SALES AND SERVICE

Honeywell Sensing and Control serves its customers through a worldwide network of sales offices and distributors. For application assistance, current specifications, pricing or name of the nearest Authorized Distributor, contact a nearby sales office or call:

#### TELEPHONE

1-800-367-6786 (USA)  
1-800-737-3360 (Canada)  
+49 (0) 89 35813310 (Germany)  
+65-580-3312 (Singapore)  
+44 (0) 118 981 9511 (UK)

#### INTERNET

<http://www.honeywell.com/VCSEL>  
VCSEL@honeywell.com

#### FAX

1-972-470-4326 (Customer Response Center)  
1-972-470-4549 (Fax on demand)  
+49 (0) 89 3599971 (Germany)  
+65 445 3033 (Singapore)  
+44 (0) 118 981 7513 (UK)

01/29/02

## Honeywell

Honeywell Inc.  
11 West Spring Street  
Freeport, Illinois 61032



Printed with Soy Ink  
on 50% Recycled Paper

PK XXXX X DMM Printed in USA



Honeywell Inc.  
Optoelectronics Facility  
830 East Arapaho Road  
Richardson, Texas 75081

**Honeywell Control  
Systems Ltd.**  
Zodiac House  
Calleva Park  
Aldermaston, Berkshire  
RG7 8HW England

*Helping You Control Your World*

[www.DataSheet4U.com](http://www.DataSheet4U.com)

## Fiber Optic LAN Components LC SFF Duplex OFE 2.5 Gbps

# HFT229x-541

### FEATURES

- Prealigned Pluggable LC Duplex Optical Front End (OFE) in compliance with the SFF Pluggable Transceiver MultiSource Agreement.
- VCSEL packaged with a back monitor photodiode
- Common anode and common cathode polarities available
- TO-46 hermetic package for VCSEL and Pin + Preamp
- 3.3 V operation
- GaAs PIN detector and BiCMOS preamplifier
- Differential output for low noise
- High Speed >1GHz
- Laser signal is attenuated

www.DataSheet4U.com

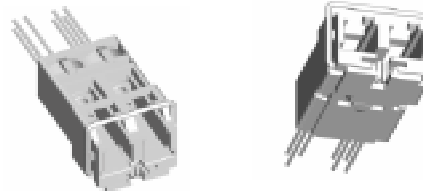

The HFT229x-541 is a single package transmitter and receiver designed to interface with the LC style optical connectors.

The transmitter is a high performance 850nm VCSEL (Vertical Cavity Surface Emitting Laser) packaged for high speed data communications. This product combines all the performance advantages of VCSEL with a custom designed power monitor diode. The power monitor diode can be used with an appropriate feedback control circuitry to set a maximum power level for each VCSEL. Attenuating coatings are available on the Laser transmitter to simplify design and assist in meeting eye safety requirements.

The PIN + preamp converts optical power into a differential output electrical signal. As the light increases, the differential output voltage increases, limiting at input powers above -10dBm. The differential output is designed to be AC coupled into a data amplifier.

The Honeywell HFT229x-541 is designed to interface with 50/125 and 62.5/125µm multimode fiber within an LC style interface.

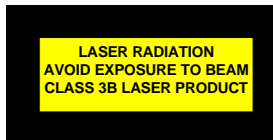

# Fiber Optic LAN Components

## LC SFF Duplex OFE 2.5 Gbps

# HFT229x-541

### VCSEL PARAMETERS

VCSEL Parameters	Test Condition	Symbol	Min.	Typ.	Max.	Units	Notes
Peak Fiber Coupled Optical Power (See threshold current and slope efficiency which control power output)	$I_F=7$ mA av. 50/125 $\mu$ m fiber NA=0.20	$P_{OC}$		500		$\mu$ W	1
Threshold Current		$I_{TH}$	1	2	3	mA	
Threshold Current Temperature Variation	$T_A = 0^\circ\text{C}$ to $70^\circ\text{C}$	$\Delta I_{TH}$	-1.5		1.5	mA	2
Slope Efficiency		$\eta$	0.04		0.16	mW/mA	3
Slope Efficiency Temperature Variation	$T_A = 0^\circ\text{C}$ to $70^\circ\text{C}$	$\Delta\eta/\Delta T$		-6000		PPM/ $^\circ\text{C}$	
Peak Wavelength	$I_F=7$ mA	$\lambda_P$	830	850	860	Nm	
$\lambda_P$ Temp Coefficient	$I_F=7$ mA	$\Delta\lambda_P/\Delta T$		0.06		nm/ $^\circ\text{C}$	
Spectral Bandwidth	$I_F=7$ mA, FWHM	$\Delta\lambda$			0.85	nm	
Laser Forward Voltage	$I_F=7$ mA	$V_F$		1.8	2.2	V	
Laser Reverse Voltage	$I_R=10$ $\mu$ A	$BVR_{LD}$		-10		V	
Rise and Fall Time	Bias Above Threshold (20%-80%)	$t_R$ $t_F$			130 150	ps	4
Relative Intensity Noise	1 GHz BW	RIN		-130	-122	dB/Hz	
Series Resistance	$I_F=7$ mA	$R_S$	22	35	55	Ohms	
Series Resistance Temperature Coefficient	$I_F=7$ mA, $0^\circ\text{C}$ to $70^\circ\text{C}$	$dR_S/dT$		-3000		PPM/ $^\circ\text{C}$	

Photodiode Parameters	Test Condition	Symbol	Min.	Typ.	Max.	Units	Notes
Monitor Current	$P_{OC}=0.5$ mW	$I_{PD}$		0.35		mA	
Monitor Current Temperature Variation	$P_{OC}=0.5$ mW	$\Delta I_{PD}/\Delta T$		0.2		%/ $^\circ\text{C}$	
Dark Current	$P_O=0$ mW, $V_R=3$ V	$I_D$			20	nA	
PD Reverse Voltage	$P_O=0$ mW, $I_R=10$ $\mu$ A	$BVR_{PD}$	30	115		V	5
PD Capacitance	$V_R=0$ V, Freq=1 MHz $V_R=3$ V, Freq=1 MHz	C		75 40	100 55	pF	

#### Notes:

1. Operating power is set by the peak operating current  $I_{PEAK}=I_{BIAS}+I_{MODULATION}$ .
2. Operation at temperatures outside the specified range may result in the threshold current exceeding the maximums defined in the electro-optical characteristics table.
3. Slope efficiency is defined as  $\Delta P_O/\Delta I_F$  at a total power output of 0.5 mW. Slope efficiency is intentionally lowered to the values shown by optical attenuation.
4. Rise and fall times are sensitive to drive electronics.
5. To safeguard the VCSEL from current spike damage, short the VCSEL anode and cathode to each other during photodiode BVR verification testing.

# Fiber Optic LAN Components

## LC SFF Duplex OFE 2.5 Gbps

# HFT229x-541

### RECEIVER PARAMETERS

**ELECTRO-OPTICAL CHARACTERISTICS** ( $V_{cc}=3.3V$ , AC coupled to  $50\Omega$ ,  $0^{\circ}C < T < 70^{\circ}C$  unless otherwise specified)

Parameters	Test Condition	Symbol	Min.	Typ.	Max.	Units	Notes
<b>Electrical Characteristics</b>							
Supply Voltage	$P_{in} = 0\mu W$ , $R_{load}=50\Omega$	$V_{cc}$	3.0	3.3	3.6	Volts	1
Supply Current	$P_{in} = 0\mu W$ , $R_{load}=50\Omega$	$I_{cc}$		26	40	mA	1
Output Offset Voltage	$P_{in} = 0\mu W$ , $R_{load}=50\Omega$	$V_{offset}$	-100		100	mV	9,10
Output Resistance	Single ended, freq = 0Hz	$R_o$	40	50	62	$\Omega$	
<b>Opto-Electronic Characteristics</b>							
Responsivity	$P_{in} < AGC_{th}$ , $R_{load}=50\Omega$	R		1400		$\mu V/\mu W$	2,3,10
Differential Output Voltage	$P_{in} = 200\mu W$ , $R_{load}=50\Omega$ , $V_{offset} = 0$ mV	$V_{out}$	90	160	400	mV	1
Upper 3dB Bandwidth		$BW_{upper}$	1700	1900	2500	MHz	4
RMS Output Referred Noise	$P_{in}=0\mu W$ , $R_{load}=50\Omega$ 1875 MHz BT Filter			1.5	2.25	mV	5
Sensitivity	$BER=10^{-12}$ , $SNR=7$	S	-17	-20		dBm	
Power Supply Rejection Ratio	$P_{in}=0\mu W$ , $R_{load}=50\Omega$	PSRR	10	30		dB	6
Pulse Width Distortion	$P_{in}=20\mu W$ peak, $R_{load}=50\Omega$	PWD			40	ps	7
Rise/Fall Time	$P_{in}=20\mu W$ peak, $R_{load}=50\Omega$	$T_R/T_F$			250	ps	8
Wavelength Responsivity	$P_{in}=20\mu W$ peak, $R_{load}=50\Omega$	$\lambda$	760	850	860	nm	
AGC <sub>th</sub> threshold power	$V_{offset} = 0$ mV, $P_{in} =$ Peak power	AGC <sub>th</sub>		60		$\mu W$	9,10

#### Notes:

- Pin refers to the peak optical power at the face of the fiber optic cable input to the HFD3180-102.
- Responsivity measured with source wavelength of 850nm, freq = 0Hz,  $P_{in} < AGC_{th}$ ,  $R_{load}=50\Omega$ , sample tested at 2.5Gbps
- The output voltage increases as received light power increases, up to approximately -15dBm depending upon the AGC<sub>th</sub>. The preamplifier is designed to limit the electrical output signal above this optical input level, and does not introduce signal distortion until the average input power exceeds 0dBm.
- Bandwidth is measured with a small signal sinusoidal light source with 50  $\mu W$  average power,  $R_{load}=50\Omega$ .
- RMS input referred optical noise is sample tested by measuring the RMS output referred noise, then dividing by the responsivity.
- PSRR is sample tested from 300KHz to 1GHz by injecting a -20dB electrical signal on the  $V_{cc}$  pin. The nominal value at 100MHz is recorded. No external bypass components are assumed. An external  $V_{cc}$  filter network will greatly increase the PSRR.
- Sample tested at the 50% level of output pulses.
- Rise and fall times are sample tested with source wavelength of 850nm, 125MHz square wave, with optical rise and fall times < 200ps,  $P_{in} < AGC_{th}$ ,  $R_{load}=50\Omega$ . Measured at 20% - 80% signal levels
- Output offset voltage is defined as  $V_{out} - V_{outQ}$  with no light
- The AGC<sub>th</sub> power depends on the offset voltage. Refer to fig 3.

# Fiber Optic LAN Components LC SFF Duplex OFE 2.5 Gbps

# HFT229x-541

## Absolute Maximum Ratings

Parameter	Rating
Storage Temperature	-40 to +85°C
Operating Temperature	0 to +70°C
Lead Solder Temperature	260°C, 10 sec.
Continuous Optical Output Power (Any Current)	5 mW
Laser Diode Reverse Voltage ( $I_R=10 \mu A$ )	5 V
Laser Continuous Forward Current, Heat-Sinked	15 mA
PIN Photodiode Forward Current	10 mA
Power Supply Voltage (PIN + Preamp)	3.8 V
Incident Optical Power	0 dBm average, +4 dBm peak

### **NOTICE**

Stresses greater than those listed under “Absolute Maximum Ratings” may cause permanent damage to the device. This is a stress rating only and functional operation of the device at these or any other conditions above those indicated in the operations section for extended periods of time may affect reliability.

### **NOTICE**

The inherent design of this component causes it to be sensitive to electrostatic discharge (ESD). To prevent ESD-induced damage and/or degradation to equipment, take normal ESD precautions when handling this product

## ORDER GUIDE

Catalog Listing	Description
HFT2290-541	Attenuated, Common Anode
HFT2291-541	Attenuated, Common Cathode



# Fiber Optic LAN Components

## LC SFF Duplex OFE 2.5 Gbps

# HFT229x-541

### TYPICAL PERFORMANCE CURVES

**Emitted Power vs. Current:** Power varies approximately linearly with current above threshold.

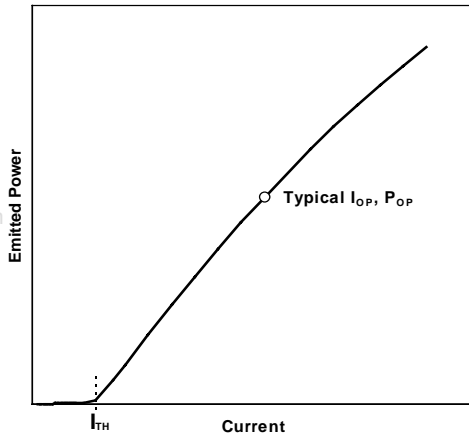

**Emission Intensity vs. Wavelength:** Typical 10 mA spectrum comprises multiple lines corresponding to multiple transverse modes.

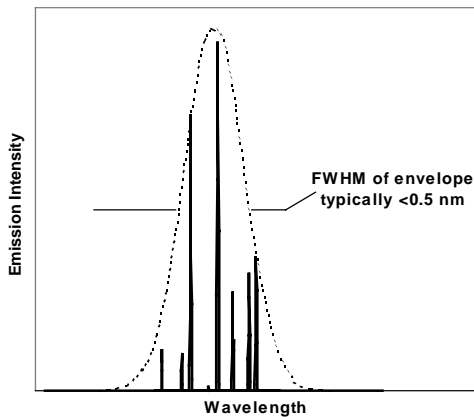

**Threshold Current vs. Temperature:** Threshold current varies parabolically with temperature; thus it can be nearly constant for a limited temperature range.

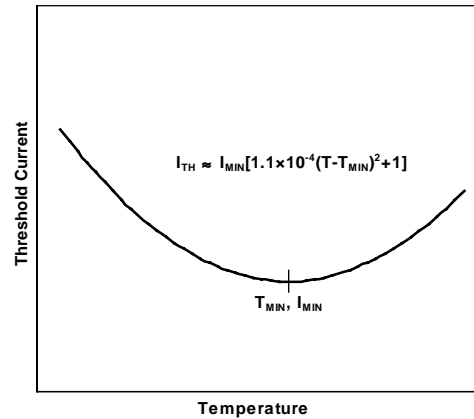

### NOTICE

The inherent design of this component causes it to be sensitive to electrostatic discharge (ESD). To prevent ESD-induced damage and/or degradation to equipment, take normal ESD precautions when handling this product.

### DANGER

The VCSEL is a class IIIb laser and should be treated as a potential eye hazard. Due to the size of the component, the applicable warning logotype, aperture label, and certification/identification label cannot be placed on the component itself. These labels can be found on the individual envelope in which the VCSEL unit is packaged, or attached to the shipping package.

# Fiber Optic LAN Components

## LC SFF Duplex OFE 2.5 Gbps

# HFT229x-541

**FIGURE 1: INTERNAL SCHEMATIC DIAGRAM OF THE HFD3180-102**

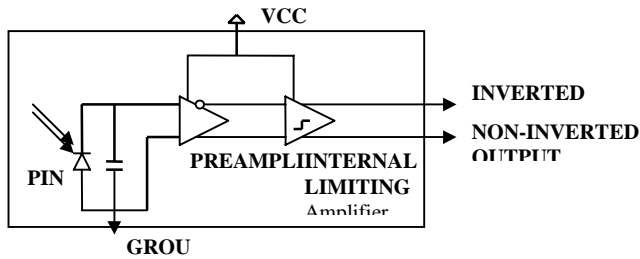

www.DataSheet4U.com

**FIGURE 2: RECOMMENDED INTERFACE CIRCUIT FOR THE HFD3180-102**

$R=10\ \Omega$

$C_1 = 10\ \text{nF}$

$C_2 = \text{Data rate dependant (22nF for rates } > 1\text{Gbps)}$

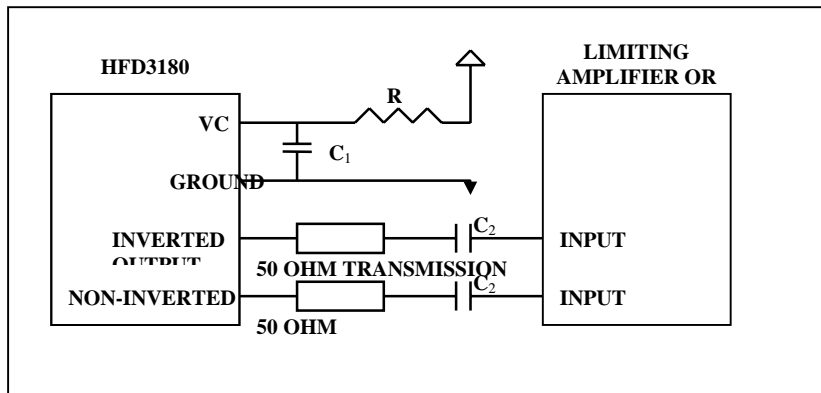

**FIGURE 3: AGC THRESHOLD POWER VS. OUTPUT OFFSET VOLTAGE**

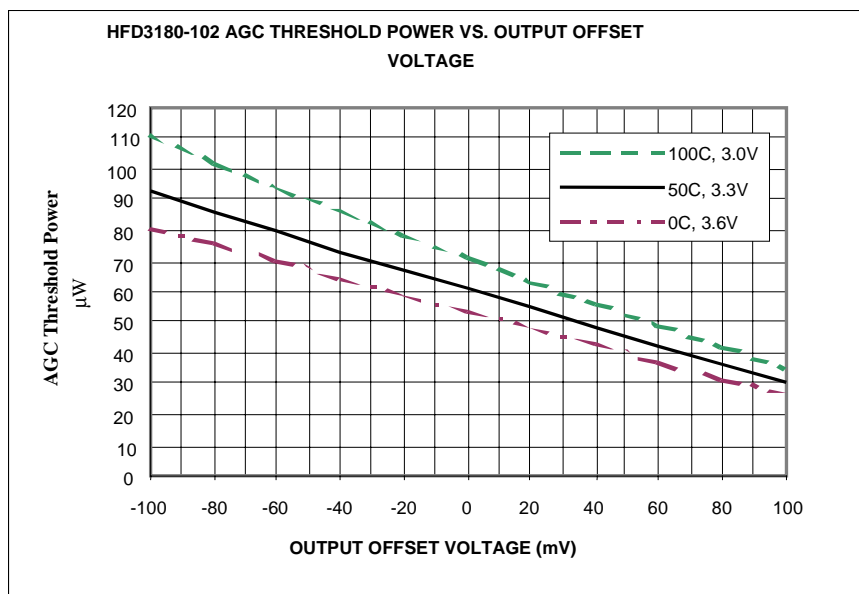

# Fiber Optic LAN Components

## LC SFF Duplex OFE 2.5 Gbps

# HFT229x-541

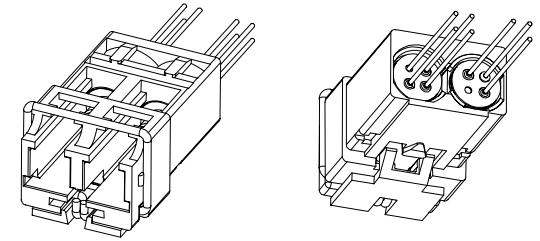
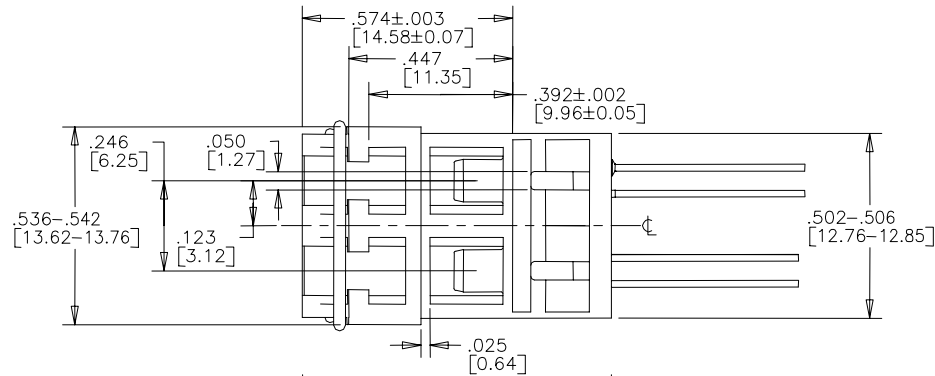

www.DataSheet4U.com

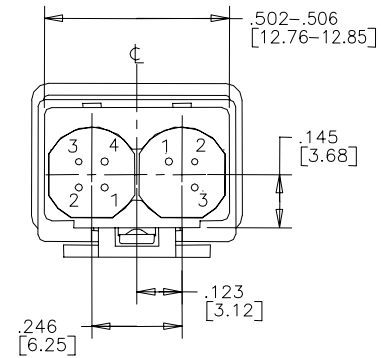
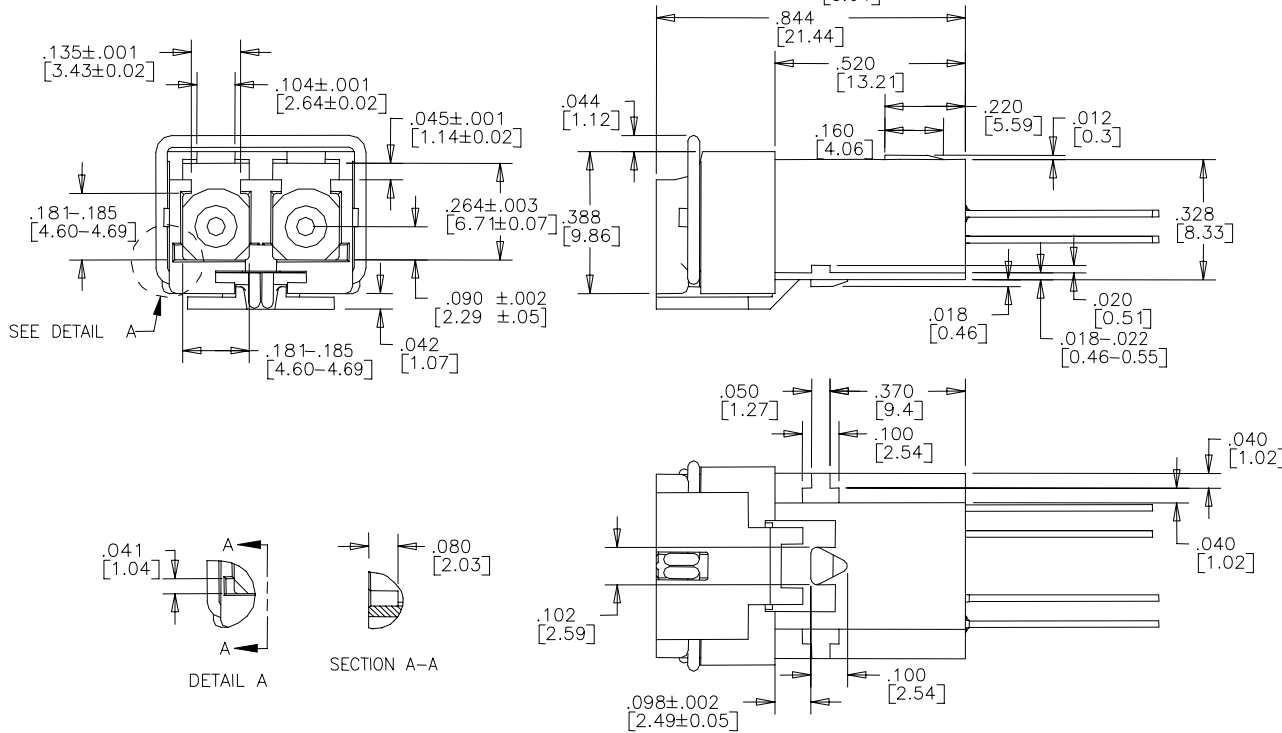

PIN #	RCVR	XMTR	
		HFT2280/2290	HFT2281/2291
1	VCC	VCSEL CATHODE	VCSEL ANODE
2	OUT-	VCSEL ANODE & PD CATH.	VCSEL CATH. & PD ANODE
3	GND	PD ANODE	PD CATHODE
4	OUT+	N/A	N/A

# Fiber Optic LAN Components

## LC SFF Duplex OFE 2.5 Gbps

# HFT229x-541

### WARRANTY/REMEDY

Honeywell warrants goods of its manufacture as being free of defective materials and faulty workmanship. Commencing with the date of shipment, Honeywell's warranty runs for 18 months. If warranted goods are returned to Honeywell during that period of coverage, Honeywell will repair or replace without charge those items it finds defective. The foregoing is Buyer's sole remedy and is **in lieu of all other warranties, expressed or implied, including those of merchantability and fitness for a particular purpose.**

While we provide application assistance, personally and through our literature, it is up to the customer to determine the suitability of the product in the application.

www.DataSheet4U.com

Specifications may change at any time without notice. The information we supply is believed to be accurate and reliable as of this printing. However, we assume no responsibility for its use.

### SALES AND SERVICE

Honeywell Sensing and Control serves its customers through a worldwide network of sales offices and distributors. For application assistance, current specifications, pricing or name of the nearest Authorized Distributor, contact a nearby sales office or call:

#### TELEPHONE

1-800-367-6786 (USA)  
1-800-737-3360 (Canada)  
+49 (0) 89 35813310 (Germany)  
+65-580-3312 (Singapore)  
+44 (0) 118 981 9511 (UK)

#### INTERNET

<http://www.honeywell.com/VCSEL>  
VCSEL@honeywell.com

#### FAX

1-972-470-4326 (Customer Response Center)  
1-972-470-4549 (Fax on demand)  
+49 (0) 89 3599971 (Germany)  
+65 445 3033 (Singapore)  
+44 (0) 118 981 7513 (UK)

01/29/02

## Honeywell

Honeywell Inc.  
11 West Spring Street  
Freeport, Illinois 61032



Printed with Soy Ink  
on 50% Recycled Paper

PK XXXX X DMM Printed in USA



Honeywell Inc.  
Optoelectronics Facility  
830 East Arapaho Road  
Richardson, Texas 75081

**Honeywell Control  
Systems Ltd.**  
Zodiac House  
Calleva Park  
Aldermaston, Berkshire  
RG7 8HW England

*Helping You Control Your World*

www.DataSheet4U.com

### LC Connectorized High Speed VCSEL 1.25Gbps

#### FEATURES

- Designed for small form factor transceivers
- Prealigned connector sleeve that is compatible with the LC standard (LC is a trademark of Lucent Technologies)
- Designed for drive currents between 5 and 15 mA
- Optimized for low dependence of electrical properties over temperature
- High speed  $\geq 1$  GHz
- Two different laser/ photodiode polarities
- Attenuating coating
- Packaged with a photodetector



The HFE418x-521 is a high-performance 850 nm VCSEL (Vertical Cavity Surface-Emitting Laser) packaged for high-speed data communications. This product combines all the performance advantages of the VCSEL with a custom designed power monitor diode. The power monitor diode can be used with appropriate feedback control circuitry to set a maximum power level for each VCSEL. In addition, built-in power attenuation reduces the effective slope efficiency. These combined features simplify design for high data rate communication and eye safety.

Packaged in a fiber receptacle sleeve, this high radiance VCSEL is designed to convert electrical current into optical power that can be used in fiber optic communications and other applications. As the current varies above threshold, the light intensity increases proportionally. Data rates can vary from DC to above 2 Gb/s.

The HFE418x-521 is designed to be used with inexpensive silicon or gallium arsenide detectors, but excellent performance can also be achieved with some indium gallium arsenide detectors.

The low drive current requirement makes direct drive from PECL (Positive Emitter Coupled Logic) or EML (Emitter Coupled Logic) gates possible and eases driver design.

The HFE418x-521 is a prealigned and focused fiber optic transmitter designed to interface with 50/125 and 62.5/125  $\mu\text{m}$  multimode fiber.

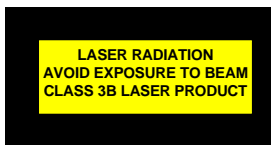

# Fiber Optic LAN Components

## LC Connectorized VCSEL 1.25Gbps

HFE418x-521

### ABSOLUTE MAXIMUM RATINGS

Parameter	Rating
Storage Temperature	-40 to +85°C
Operating Temperature	0 to +70°C
Lead Solder Temperature	260°C, 10 sec.
Continuous Optical Output Power (Any Current)	5 mW
Laser Diode Reverse Voltage ( $I_R=10 \mu A$ )	5 V
Laser Continuous Forward Current, Heat-Sinked	15 mA
PIN Photodiode Forward Current	10 mA

### NOTICE

Stresses greater than those listed under “Absolute Maximum Ratings” may cause permanent damage to the device. This is a stress rating only and functional operation of the device at these or any other conditions above those indicated in the operations section for extended periods of time may affect reliability.

www.DataSheet4U.com

### ELECTRO-OPTICAL CHARACTERISTICS ( $T_A=25^\circ C$ unless otherwise stated)

VCSEL Parameters	Test Condition	Symbol	Min.	Typ.	Max.	Units	Notes
Peak Fiber Coupled Optical Power (See threshold current and slope efficiency which control power output)	$I_F=12$ mA Peak 50/125 $\mu m$ fiber NA=0.20	$P_{OC}$		350 -4.5		$\mu W$ dBm	1
Coupling Efficiency	$I_F=12$ mA	PO_PCT	65			%	2
Threshold Current		$I_{TH}$		3.5	6	mA	
Threshold Current Temperature Variation	$T_A = 0^\circ C$ to $70^\circ C$	$\Delta I_{TH}$	-1.5		1.5	mA	3
Slope Efficiency	$P_{OC}=0.35$ mW	$\eta$	0.02	0.04	0.1	mW/mA	4
Slope Efficiency Temperature Variation	$T_A = 0^\circ C$ to $70^\circ C$	$\Delta\eta/\Delta T$		-0.5		%/ $^\circ C$	
Peak Wavelength	$I_F=12$ mA	$\lambda_p$	830	850	860	nm	
$\lambda_p$ Temp Coefficient	$I_F=12$ mA	$\Delta\lambda_p/\Delta T$		0.06		nm/ $^\circ C$	
Spectral Bandwidth	$I_F=12$ mA, FWHM	$\Delta\lambda$			1.0	nm	
Laser Forward Voltage	$I_F=12$ mA	$V_F$	1.6	1.8	2.2	V	
Laser Reverse Voltage	$I_R=10 \mu A$	$BVR_{LD}$	5	10		V	
Rise and Fall Time	Bias Above Threshold (20%-80%)	$t_R$ $t_F$		150 200	300 300	ps	5
Relative Intensity Noise	1 GHz BW	RIN		-128	-122	dB/Hz	
Series Resistance	$I_F=12$ mA	$R_S$	15	25	50	Ohms	

Photodiode Parameters	Test Condition	Symbol	Min.	Typ.	Max.	Units	Notes
Monitor Current	$P_{OC}=0.35$ mW	$I_{PD}$	0.09		0.58	mA	
Monitor Current Temperature Variation	$P_{OC}=0.35$ mW	$\Delta I_{PD}/\Delta T$		0.0		%/ $^\circ C$	
Dark Current	$P_o=0$ mW, $V_R=3$ V	$I_D$			20	nA	
PD Reverse Voltage	$P_o=0$ mW, $I_R=10 \mu A$	$BVR_{PD}$	30	115		V	6
PD Capacitance	$V_R=0$ V, Freq=1 MHz $V_R=3$ V, Freq=1 MHz	C		75 40	100 55	pF	

### Notes:

- Operating power is set by the peak operating current  
 $I_{PEAK}=I_{BIAS}+I_{MODULATION}$ .
- PO\_PCT is defined as the ratio of the coupled power into a 50/125 micron fiber to the total power output from the component as measured on a large area detector.

# Fiber Optic Components

## LC Connectorized VCSEL 1.25Gbps

HFE418x-521

3. Operation at temperatures outside the specified range may result in the threshold current exceeding the maximums defined in the electro-optical characteristics table.
4. Slope efficiency is defined as  $\Delta P_o / \Delta I_F$  at a total power output of 0.35 mW. Slope efficiency is intentionally lowered to the values shown by optical attenuation.
5. Rise and fall times are sensitive to drive electronics. 200 ps rise and fall times are achievable for all Honeywell VCSELs.
6. To safeguard the VCSEL from current spike damage, short the VCSEL anode and cathode to each other during photodiode BVR verification testing.

### TYPICAL PERFORMANCE CURVES

www.DataSheet4U.com

**Emitted Power vs. Current:** Power varies approximately linearly with current above threshold.

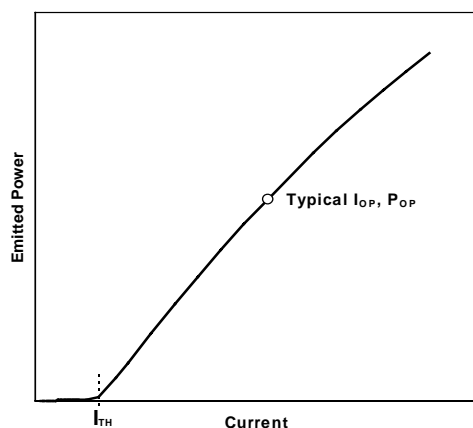

**Emission Intensity vs. Wavelength:** Typical 10 mA spectrum comprises multiple lines corresponding to multiple transverse modes.

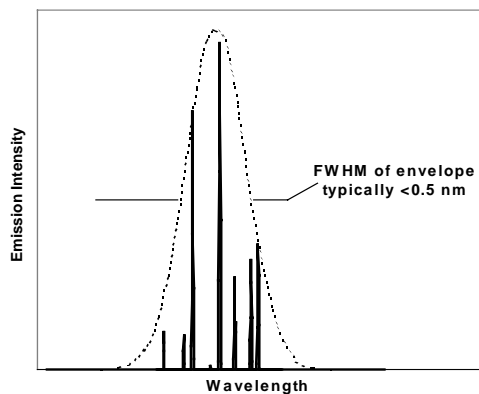

**Threshold Current vs. Temperature:** Threshold current varies parabolically with temperature; thus it can be nearly constant for a limited temperature range.

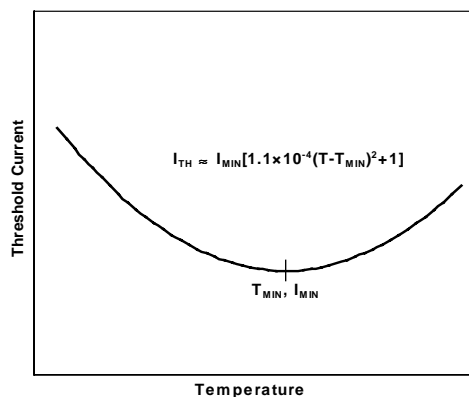

### NOTICE

The inherent design of this component causes it to be sensitive to electrostatic discharge (ESD). To prevent ESD-induced damage and/or degradation to equipment, take normal ESD precautions when handling this product.



The VCSEL is a class IIIb laser and should be treated as a potential eye hazard. Due to the size of the component, the applicable warning logotype, aperture label, and certification/identification label cannot be placed on the component itself. These labels can be found on the individual envelope in which the VCSEL unit is packaged, or attached to the shipping package.

# Fiber Optic LAN Components

## LC Connectorized VCSEL 1.25Gbps

# HFE418x-521

### ORDER GUIDE

Catalog Listing	Description
HFE4180-521	Attenuated VCSEL with Back Monitor Photodiode - VCSEL Anode Common
HFE4181-521	Attenuated VCSEL with Back Monitor Photodiode - VCSEL Cathode Common

### MOUNTING DIMENSIONS (for reference only): in./(mm)

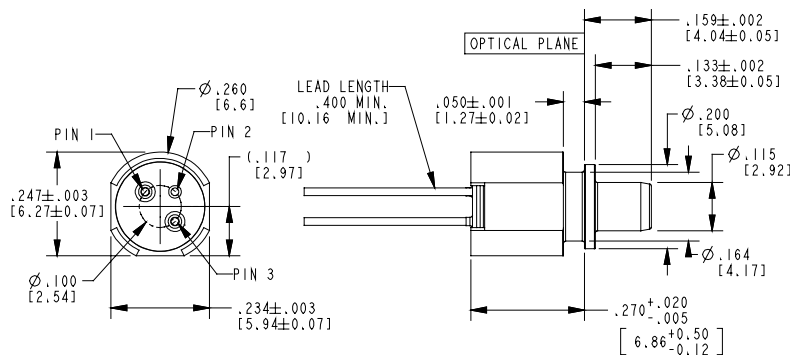

### PINOUT

HFE4180-521		HFE4181-521	
Number	Function	Number	Function
1	K <sub>LD</sub>	1	A <sub>LD</sub>
2	K <sub>PD</sub> , A <sub>LD</sub>	2	K <sub>LD</sub> , A <sub>PD</sub>
3	A <sub>PD</sub>	3	K <sub>PD</sub>

### PINOUT DEFINITIONS

A <sub>LD</sub>	VCSEL Anode	A <sub>PD</sub>	Monitor Photodiode Anode
K <sub>LD</sub>	VCSEL Cathode	K <sub>PD</sub>	Monitor Photodiode Cathode

### WARRANTY/REMEDY

Honeywell warrants goods of its manufacture as being free of defective materials and faulty workmanship. Commencing with the date of shipment, Honeywell's warranty runs for 18 months. If warranted goods are returned to Honeywell during that period of coverage, Honeywell will repair or replace without charge those items it finds defective. The foregoing is Buyer's sole remedy and is **in lieu of all other warranties, expressed or implied, including those of merchantability and fitness for a particular purpose.**

7/6/01

# Honeywell

Honeywell Inc.  
11 West Spring Street  
Freeport, Illinois 61032



Honeywell Inc.  
Optoelectronics Facility  
830 East Arapaho Road  
Richardson, Texas 75081

**Honeywell Control Systems Ltd.**  
Zodiac House  
Calleva Park  
Aldermaston, Berkshire  
RG7 8HW England

*Helping You Control Your World*



Printed with Soy Ink  
on 50% Recycled Paper

006694-1-EN IL50 GLO 797 Printed in USA

[www.DataSheet4U.com](http://www.DataSheet4U.com)

While we provide application assistance, personally and through our literature, it is up to the customer to determine the suitability of the product in the application.

Specifications may change at any time without notice. The information we supply is believed to be accurate and reliable as of this printing. However, we assume no responsibility for its use.

### SALES AND SERVICE

Honeywell Sensing and Control serves its customers through a worldwide network of sales offices and distributors. For application assistance, current specifications, pricing or name of the nearest Authorized Distributor, contact a nearby sales office or call:

### TELEPHONE

1-800-367-6786 (USA)  
1-800-737-3360 (Canada)  
+49 (0) 89 35813310 (Germany)  
+65-580-3312 (Singapore)  
+44 (0) 118 981 9511 (UK)

### FAX

1-972-470-4326 (Customer Response Center)  
1-972-470-4549 (Fax on demand)  
+49 (0) 89 3599971 (Germany)  
+65 445 3033 (Singapore)  
+44 (0) 118 981 7513 (UK)

### INTERNET

<http://www.honeywell.com/sensing/VCSEL>  
[info.sc@honeywell.com](mailto:info.sc@honeywell.com)



## Fiber Optic LAN Components

## HFE438x-521

### SC Connectorized High Speed VCSEL 1.25Gbps

#### FEATURES

- Designed for drive currents between 5 and 15 mA
- Optimized for low dependence of electrical properties over temperature
- High speed  $\geq 1$  GHz
- Two different laser/photodiode polarities
- Attenuating coating
- Packaged with a photodetector

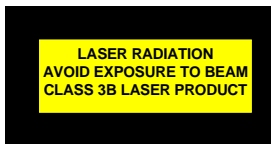

The HFE438x-521 is a high-performance 850 nm VCSEL (Vertical Cavity Surface-Emitting Laser) packaged for high-speed data communications. This product combines all the performance advantages of the VCSEL with a custom designed power monitor diode. The power monitor diode can be used with appropriate feedback control circuitry to set a maximum power level for each VCSEL. In addition, built-in power attenuation reduces the effective slope efficiency. These combined features simplify design for high data rate communication and eye safety.

Packaged in a fiber receptacle sleeve, this high radiance VCSEL is designed to convert electrical current into optical power that can be used in fiber optic communications and other applications. As the current varies above threshold, the light intensity increases proportionally.

The HFE438x-521 is designed to be used with inexpensive silicon or gallium arsenide detectors, but excellent performance can also be achieved with some indium gallium arsenide detectors.

The low drive current requirement makes direct drive from PECL (Positive Emitter Coupled Logic) or EML (Emitter Coupled Logic) gates possible and eases driver design.

The HFE438x-521 is a prealigned and focused fiber optic transmitter designed to interface with 50/125 and 62.5/125  $\mu\text{m}$  multimode fiber.

# Fiber Optic LAN Components

## SC Connectorized VCSEL 1.25Gbps

HFE438x-521

### ABSOLUTE MAXIMUM RATINGS

Parameter	Rating
Storage Temperature	-40 to +85°C
Operating Temperature	0 to +70°C
Lead Solder Temperature	260°C, 10 sec.
Continuous Optical Output Power (Any Current)	5 mW
Laser Diode Reverse Voltage ( $I_R=10 \mu A$ )	5 V
Laser Continuous Forward Current, Heat-Sinked	15 mA
PIN Photodiode Forward Current	10 mA

### NOTICE

Stresses greater than those listed under “Absolute Maximum Ratings” may cause permanent damage to the device. This is a stress rating only and functional operation of the device at these or any other conditions above those indicated in the operations section for extended periods of time may affect reliability.

www.DataSheet4U.com

### ELECTRO-OPTICAL CHARACTERISTICS ( $T_A=25^\circ C$ unless otherwise stated)

VCSEL Parameters	Test Condition	Symbol	Min.	Typ.	Max.	Units	Notes
Peak Fiber Coupled Optical Power (See threshold current and slope efficiency which control power output)	$I_F=12$ mA Peak 50/125 $\mu$ m fiber NA=0.20	$P_{OC}$		350 -4.5		$\mu$ W dBm	1
Threshold Current		$I_{TH}$		3.5	6	mA	
Threshold Current Temperature Variation	$T_A = 0^\circ C$ to $70^\circ C$	$\Delta I_{TH}$	-1.5		1.5	mA	2
Slope Efficiency	$P_{OC}=0.35$ mW	$\eta$	0.02	0.04	0.1	mW/mA	3
Slope Efficiency Temperature Variation	$T_A = 0^\circ C$ to $70^\circ C$	$\Delta\eta/\Delta T$		-0.5		%/ $^\circ C$	
Peak Wavelength	$I_F=12$ mA	$\lambda_p$	830	850	860	nm	
$\lambda_p$ Temp Coefficient	$I_F=12$ mA	$\Delta\lambda_p/\Delta T$		0.06		nm/ $^\circ C$	
Spectral Bandwidth	$I_F=12$ mA, FWHM	$\Delta\lambda$			1.0	nm	
Laser Forward Voltage	$I_F=12$ mA	$V_F$	1.6	1.8	2.2	V	
Laser Reverse Voltage	$I_R=10 \mu A$	$BVR_{LD}$	5	10		V	
Rise and Fall Time	Bias Above Threshold (20%-80%)	$t_R$ $t_F$		150 200	300 300	ps	4
Relative Intensity Noise	1 GHz BW	RIN		-128	-122	dB/Hz	
Series Resistance	$I_F=12$ mA	$R_S$	15	25	50	Ohms	

Photodiode Parameters	Test Condition	Symbol	Min.	Typ.	Max.	Units	Notes
Monitor Current	$P_{OC}=0.35$ mW	$I_{PD}$	0.09		0.58	mA	
Monitor Current Temperature Variation	$P_{OC}=0.35$ mW	$\Delta I_{PD}/\Delta T$		0.0		%/ $^\circ C$	
Dark Current	$P_o=0$ mW, $V_R=3$ V	$I_D$			20	nA	
PD Reverse Voltage	$P_o=0$ mW, $I_R=10 \mu A$	$BVR_{PD}$	30	115		V	5
PD Capacitance	$V_R=0$ V, Freq=1 MHz $V_R=3$ V, Freq=1 MHz	C		75 40	100 55	pF	

### Notes:

- Operating power is set by the peak operating current  
 $I_{PEAK}=I_{BIAS}+I_{MODULATION}$
- Operation at temperatures outside the specified range may result in the threshold current exceeding the maximums defined in the electro-optical characteristics table.
- Slope efficiency is defined as  $\Delta P_o/\Delta I_F$  at a total power output of 0.35 mW. Slope efficiency is intentionally lowered to the values shown by optical attenuation.

# Fiber Optic Components

## SC Connectorized VCSEL 1.25Gbps

HFE438x-521

4. Rise and fall times are sensitive to drive electronics. 200 ps rise and fall times are achievable for all Honeywell VCSELs.
5. To safeguard the VCSEL from current spike damage, short the VCSEL anode and cathode to each other during photodiode BVR verification testing.

### TYPICAL PERFORMANCE CURVES

**Emitted Power vs. Current:** Power varies approximately linearly with current above threshold.

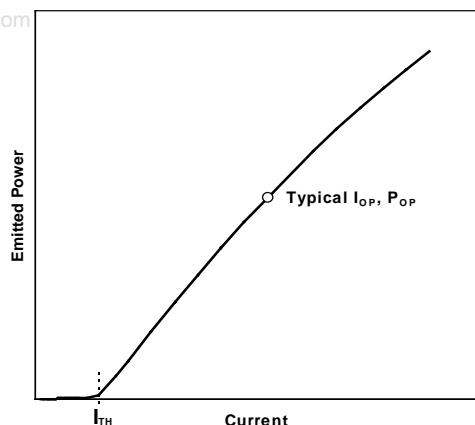

**Threshold Current vs. Temperature:** Threshold current varies parabolically with temperature; thus it can be nearly constant for a limited temperature range.

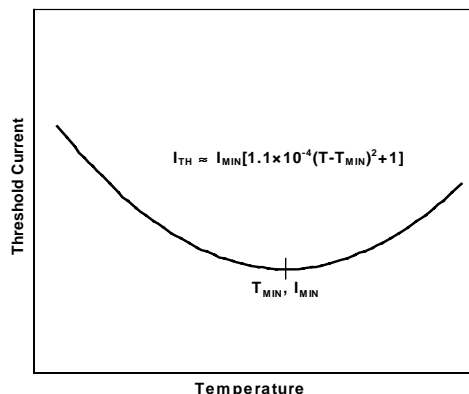

**Emission Intensity vs. Wavelength:** Typical 10 mA spectrum comprises multiple lines corresponding to multiple transverse modes.

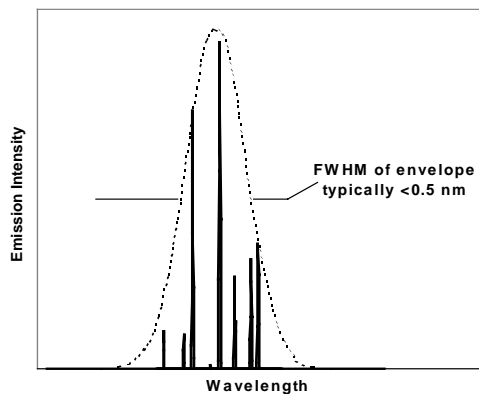

### NOTICE

The inherent design of this component causes it to be sensitive to electrostatic discharge (ESD). To prevent ESD-induced damage and/or degradation to equipment, take normal ESD precautions when handling this product.

### DANGER

The VCSEL is a class IIIb laser and should be treated as a potential eye hazard. Due to the size of the component, the applicable warning logotype, aperture label, and certification/identification label cannot be placed on the component itself. These labels can be found on the individual envelope in which the VCSEL unit is packaged, or attached to the shipping package.

# Fiber Optic LAN Components

## SC Connectorized VCSEL 1.25Gbps

HFE438x-521

### ORDER GUIDE

Catalog Listing	Description
HFE4380-521	Attenuated VCSEL with Back Monitor Photodiode - VCSEL Anode Common
HFE4381-521	Attenuated VCSEL with Back Monitor Photodiode - VCSEL Cathode Common

### MOUNTING DIMENSIONS (for reference only): in./(mm)

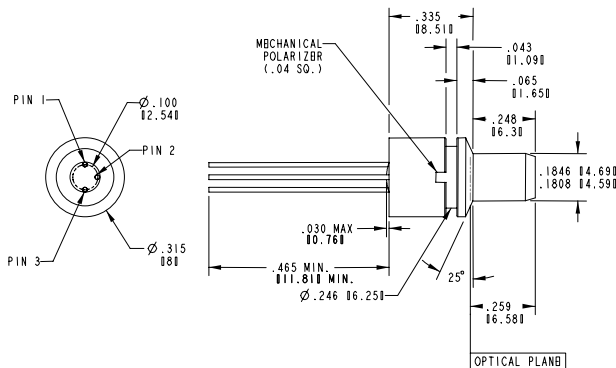

Specifications may change at any time without notice. The information we supply is believed to be accurate and reliable as of this printing. However, we assume no responsibility for its use.

### SALES AND SERVICE

Honeywell Sensing and Control serves its customers through a worldwide network of sales offices and distributors. For application assistance, current specifications, pricing or name of the nearest Authorized Distributor, contact a nearby sales office or call:

### TELEPHONE

1-800-367-6786 (USA)  
 1-800-737-3360 (Canada)  
 +49 (0) 89 35813310 (Germany)  
 +65-580-3312 (Singapore)  
 +44 (0) 118 981 9511 (UK)

### FAX

1-972-470-4326 (Customer Response Center)  
 1-972-470-4549 (Fax on demand)  
 +49 (0) 89 3599971 (Germany)  
 +65 445 3033 (Singapore)  
 +44 (0) 118 981 7513 (UK)

### INTERNET

<http://www.honeywell.com/sensing/VCSEL>  
[info.sc@honeywell.com](mailto:info.sc@honeywell.com)

### PINOUT

HFE4380-521		HFE4381-521	
Number	Function	Number	Function
1	K <sub>LD</sub>	1	A <sub>LD</sub>
2	K <sub>PD</sub> , A <sub>LD</sub>	2	K <sub>LD</sub> , A <sub>PD</sub>
3	A <sub>PD</sub>	3	K <sub>PD</sub>

### PINOUT DEFINITIONS

A <sub>LD</sub>	VCSEL Anode	A <sub>PD</sub>	Monitor Photodiode Anode
K <sub>LD</sub>	VCSEL Cathode	K <sub>PD</sub>	Monitor Photodiode Cathode

### WARRANTY/REMEDY

Honeywell warrants goods of its manufacture as being free of defective materials and faulty workmanship. Commencing with the date of shipment, Honeywell's warranty runs for 18 months. If warranted goods are returned to Honeywell during that period of coverage, Honeywell will repair or replace without charge those items it finds defective. The foregoing is Buyer's sole remedy and is **in lieu of all other warranties, expressed or implied, including those of merchantability and fitness for a particular purpose.**

While we provide application assistance, personally and through our literature, it is up to the customer to determine the suitability of the product in the application.

7/23/01

# Honeywell

Honeywell Inc.  
 11 West Spring Street  
 Freeport, Illinois 61032



Honeywell Inc.  
 Optoelectronics Facility  
 830 East Arapaho Road  
 Richardson, Texas 75081

**Honeywell Control Systems Ltd.**  
 Zodiac House  
 Calleva Park  
 Aldermaston, Berkshire  
 RG7 8HW England

*Helping You Control Your World*

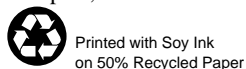

006694-1-EN IL50 GLO 797 Printed in USA

[www.DataSheet4U.com](http://www.DataSheet4U.com)

### SC Connectorized High Speed VCSEL 1.25Gbps

#### FEATURES

- Designed for drive currents between 5 and 15 mA
- Optimized for low dependence of electrical properties over temperature
- High speed  $\geq 1$  GHz
- Two different laser/photodiode polarities
- Attenuating coating also available
- Packaged with a photodetector



The HFE438x-522 is a high-performance 850 nm VCSEL (Vertical Cavity Surface-Emitting Laser) packaged for high-speed data communications. This product combines all the performance advantages of the VCSEL with a custom designed power monitor diode. The power monitor diode can be used with appropriate feedback control circuitry to set a maximum power level for each VCSEL, simplifying design for high data rate communication and eye safety.

Packaged in a fiber receptacle sleeve, this high radiance VCSEL is designed to convert electrical current into optical power that can be used in fiber optic communications and other applications. As the current varies above threshold, the light intensity increases proportionally.

The HFE438x-522 is designed to be used with inexpensive silicon or gallium arsenide detectors, but excellent performance can also be achieved with some indium gallium arsenide detectors.

The low drive current requirement makes direct drive from PECL (Positive Emitter Coupled Logic) or EML (Emitter Coupled Logic) gates possible and eases driver design.

The HFE438x-522 is a prealigned and focused fiber optic transmitter designed to interface with 50/125 and 62.5/125  $\mu\text{m}$  multimode fiber.

LASER RADIATION  
AVOID EXPOSURE TO BEAM  
CLASS 3B LASER PRODUCT



# Fiber Optic LAN Components

## SC Connectorized VCSEL 1.25Gbps

HFE438x-522

### ABSOLUTE MAXIMUM RATINGS

Parameter	Rating
Storage Temperature	-40 to +85°C
Operating Temperature	0 to +70°C
Lead Solder Temperature	260°C, 10 sec.
Continuous Optical Output Power (Any Current)	5 mW
Laser Diode Reverse Voltage ( $I_R=10 \mu A$ )	5 V
Laser Continuous Forward Current, Heat-Sinked	15 mA
PIN Photodiode Forward Current	10 mA

### NOTICE

Stresses greater than those listed under “Absolute Maximum Ratings” may cause permanent damage to the device. This is a stress rating only and functional operation of the device at these or any other conditions above those indicated in the operations section for extended periods of time may affect reliability.

www.DataSheet4U.com

### ELECTRO-OPTICAL CHARACTERISTICS ( $T_A=25^\circ C$ unless otherwise stated)

VCSEL Parameters	Test Condition	Symbol	Min.	Typ.	Max.	Units	Notes
Peak Fiber Coupled Optical Power (See Threshold current and slope efficiency which control power output)	$I_F=12mA$ Peak 50/125 $\mu m$ fiber NA = 0.20	$P_{oc}$		1		mW	1
				0		dBm	
Threshold Current		$I_{TH}$	1.5	3.5	6	mA	
Threshold Current Temperature Variation	$T_A = 0^\circ C$ to $70^\circ C$	$\Delta I_{TH}$	-1.5		1.5	mA	2
Slope Efficiency	$P_{oc} = 1.0mW$	$\eta$	0.06	0.15	0.3	mW/mA	3
Slope Efficiency Temperature variation	$T_A = 0^\circ C$ to $70^\circ C$	$\Delta \eta / \Delta T$		-0.5		%/ $^\circ C$	
Peak Wavelength	$I_F=12mA$	$\lambda_p$	830	850	860	nm	
$\lambda_p$ Temperature Variation	$I_F=12mA$	$\Delta \lambda_p / \Delta T$		0.06		nm/ $^\circ C$	
Spectral Bandwidth, RMS	$I_F=12mA$	$\Delta \lambda$			0.85	nm	
Laser Forward Voltage	$I_F=12 mA$	$V_F$	1.6	1.8	2.2	V	
Laser Reverse Voltage	$I_R=10 \mu A$	$BVR_{LD}$	5	10		V	
Rise and Fall Times	Prebias Above Threshold, 20%-80%	$t_r$ $t_f$		150	300	ps	4
				200	300		
Relative Intensity Noise	1 GHz BW, $I_F=12mA$	RIN		-128	-122	dB/Hz	
Series Resistance	$I_F=12 mA$	$R_S$	18	25	40	Ohms	
Photodiode Parameters	Test Conditions	Symbol	Min.	Typ.	Max.	Units	Notes
Monitor Current	$P_{oc} = 1.0mW$	$I_{PD}$	0.04		0.15	mA	
Monitor current Temperature Variation	$P_{oc} = 1.0mW$	$\Delta I_{PD} / \Delta T$		0.0		%/ $^\circ C$	
Dark Current	$P_o = 0mW$ , $V_R=3V$	$I_D$			20	nA	
PD Reverse Voltage	$P_o = 0mW$ , $I_R=10 \mu A$	$BVR_{PD}$	30	115		V	5
PD Capacitance	$V_R=0V$ , Freq=1MHz	C		75	100	pF	
	$V_R=3V$ , Freq=1MHz			40	55		

# Fiber Optic Components

## SC Connectorized VCSEL 1.25Gbps

HFE438x-522

### Notes:

1. Operating power is set by the peak operating current  
 $I_{PEAK} = I_{BIAS} + I_{MODULATION}$
2. Operation at temperatures outside the specified range may result in the threshold current exceeding the maximums defined in the electro-optical characteristics table.
3. Slope efficiency is defined as  $\Delta P_o / \Delta I_F$  at a total power output of 1.0 mW.
4. Rise and fall times are sensitive to drive electronics. 200 ps rise and fall times are achievable for all Honeywell VCSELs.
5. To safeguard the VCSEL from current spike damage, short the VCSEL anode and cathode to each other during photodiode BVR verification testing.

www.DataSheet4U.com

### TYPICAL PERFORMANCE CURVES

**Emitted Power vs. Current:** Power varies approximately linearly with current above threshold.

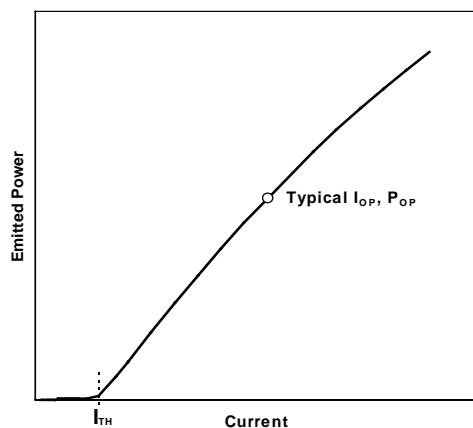

**Emission Intensity vs. Wavelength:** Typical 10 mA spectrum comprises multiple lines corresponding to multiple transverse modes.

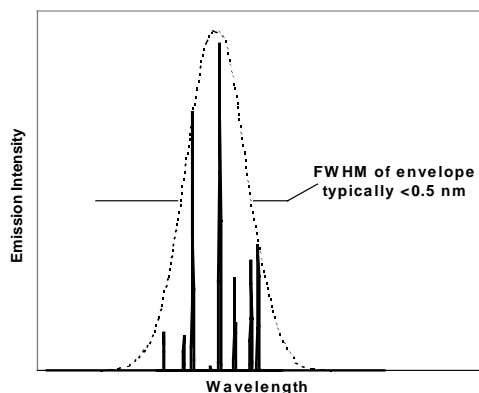

**Threshold Current vs. Temperature:** Threshold current varies parabolically with temperature; thus it can be nearly constant for a limited temperature range.

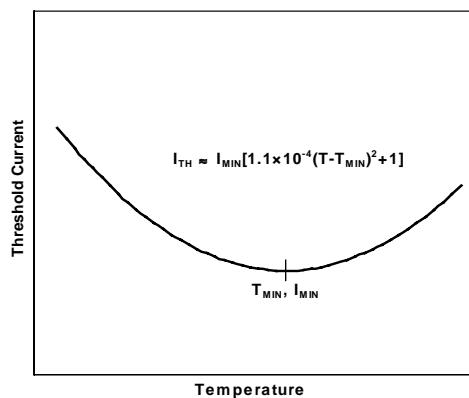

### NOTICE

The inherent design of this component causes it to be sensitive to electrostatic discharge (ESD). To prevent ESD-induced damage and/or degradation to equipment, take normal ESD precautions when handling this product.

### DANGER

The VCSEL is a class IIIb laser and should be treated as a potential eye hazard. Due to the size of the component, the applicable warning logotype, aperture label, and certification/identification label cannot be placed on the component itself. These labels can be found on the individual envelope in which the VCSEL unit is packaged, or attached to the shipping package.

# Fiber Optic LAN Components

## SC Connectorized VCSEL 1.25Gbps

HFE438x-522

### ORDER GUIDE

Catalog Listing	Description
HFE4383-522	Unattenuated VCSEL with Back Monitor Photodiode - VCSEL Anode Common
HFE4384-522	Unattenuated VCSEL with Back Monitor Photodiode - VCSEL Cathode Common

### MOUNTING DIMENSIONS (for reference only): in./(mm)

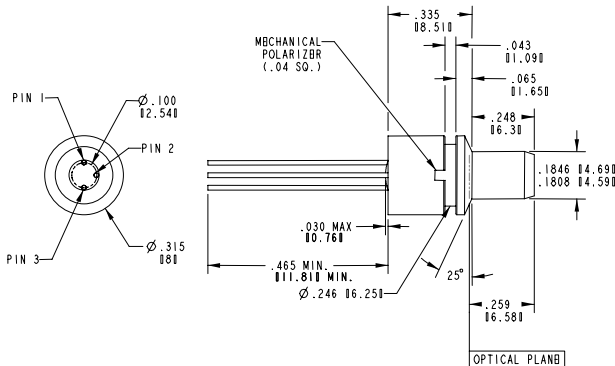

Specifications may change at any time without notice. The information we supply is believed to be accurate and reliable as of this printing. However, we assume no responsibility for its use.

### SALES AND SERVICE

Honeywell Sensing and Control serves its customers through a worldwide network of sales offices and distributors. For application assistance, current specifications, pricing or name of the nearest Authorized Distributor, contact a nearby sales office or call:

### TELEPHONE

1-800-367-6786 (USA)  
 1-800-737-3360 (Canada)  
 +49 (0) 89 35813310 (Germany)  
 +65 3546768 (Singapore)  
 +44 (0) 118 981 9511 (UK)  
 1-972-470-4271 (International)

### FAX

1-972-470-4326 (Customer Response Center)  
 1-972-470-4549 (Fax on demand)  
 +49 (0) 89 3599971 (Germany)  
 +65 35436775 (Singapore)  
 +44 (0) 118 981 7513 (UK)

### INTERNET

<http://www.honeywell.com/sensing>  
[opto@micro.honeywell.com](mailto:opto@micro.honeywell.com)

### PINOUT

HFE4383-522		HFE4384-522	
Number	Function	Number	Function
1	K <sub>LD</sub>	1	A <sub>LD</sub>
2	K <sub>PD</sub> , A <sub>LD</sub>	2	K <sub>LD</sub> , A <sub>PD</sub>
3	A <sub>PD</sub>	3	K <sub>PD</sub>

### PINOUT DEFINITIONS

A <sub>LD</sub>	VCSEL Anode	A <sub>PD</sub>	Monitor Photodiode Anode
K <sub>LD</sub>	VCSEL Cathode	K <sub>PD</sub>	Monitor Photodiode Cathode

### WARRANTY/REMEDY

Honeywell warrants goods of its manufacture as being free of defective materials and faulty workmanship. Commencing with the date of shipment, Honeywell's warranty runs for 18 months. If warranted goods are returned to Honeywell during that period of coverage, Honeywell will repair or replace without charge those items it finds defective. The foregoing is Buyer's sole remedy and is **in lieu of all other warranties, expressed or implied, including those of merchantability and fitness for a particular purpose.**

While we provide application assistance, personally and through our literature, it is up to the customer to determine the suitability of the product in the application.

12/01/00

# Honeywell

Honeywell Inc.  
 11 West Spring Street  
 Freeport, Illinois 61032



Honeywell Inc.  
 Optoelectronics Facility  
 830 East Arapaho Road  
 Richardson, Texas 75081

**Honeywell Control Systems Ltd.**  
 Zodiac House  
 Calleva Park  
 Aldermaston, Berkshire  
 RG7 8HW England

*Helping You Control Your World*

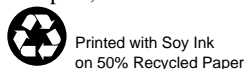

006694-1-EN IL50 GLO 797 Printed in USA

[www.DataSheet4U.com](http://www.DataSheet4U.com)



## Fiber Optic LAN Components LC SFF Duplex OFE 1.25 Gbps

# HFT218x-521

### FEATURES

- Prealigned Fixed LC Duplex Optical Front End (OFE)
- VCSEL packaged with a back monitor photodiode
- Common anode and common cathode polarities available
- TO-46 hermetic package for VCSEL and Pin + Preamp
- 5V or 3.3 V operation
- GaAs PIN detector and BiCMOS preamplifier
- Differential output for low noise
- High Speed >1GHz
- Laser signal is attenuated
- Unattenuated versions available as well (HFT2183-522 and HFT2184-522)

LASER RADIATION  
AVOID EXPOSURE TO BEAM  
CLASS 3B LASER PRODUCT



The HFT218x-52x is a single package transmitter and receiver designed to interface with the LC style optical connectors.

The transmitter is a high performance 850nm VCSEL (Vertical Cavity Surface Emitting Laser) packaged for high speed data communications. This product combines all the performance advantages of VCSEL with a custom designed power monitor diode. The power monitor diode can be used with an appropriate feedback control circuitry to set a maximum power level for each VCSEL. Attenuating coatings are available on the Laser transmitter to simplify design and assist in meeting eye safety requirements.

The PIN + preamp converts optical power into a differential output electrical signal. As the light increases, the differential output voltage increases, limiting at input powers above -10dBm. The differential output is designed to be AC coupled into a data amplifier.

The Honeywell HFT218x-521 is designed to interface with 50/125 and 62.5/125µm multimode fiber within an LC style interface.

# Fiber Optic LAN Components

## LC SFF Duplex OFE 1.25 Gbps

# HFT218x-521

### VCSEL PARAMETERS

#### ELECTRO-OPTICAL CHARACTERISTICS ( $T_A=25^\circ\text{C}$ unless otherwise stated)

VCSEL Parameters	Test Condition	Symbol	Min.	Typ.	Max.	Units	Notes
Peak Fiber Coupled Optical Power (See threshold current and slope efficiency which control power output)	$I_F=12$ mA Peak 50/125 $\mu\text{m}$ fiber NA=0.20	$P_{OC}$		350 -4.5		$\mu\text{W}$ dBm	1
Threshold Current		$I_{TH}$		3.5	6	mA	
Threshold Current Temperature Variation	$T_A = 0^\circ\text{C}$ to $70^\circ\text{C}$	$\Delta I_{TH}$	-1.5		1.5	mA	2
Slope Efficiency	$P_{OC}=0.35$ mW	$\eta$	0.02	0.04	0.1	mW/mA	3
Slope Efficiency Temperature Variation	$T_A = 0^\circ\text{C}$ to $70^\circ\text{C}$	$\Delta\eta/\Delta T$		-0.5		%/ $^\circ\text{C}$	
Peak Wavelength	$I_F=12$ mA	$\lambda_P$	830	850	860	nm	
$\lambda_P$ Temp Coefficient	$I_F=12$ mA	$\Delta\lambda_P/\Delta T$		0.06		nm/ $^\circ\text{C}$	
Spectral Bandwidth	$I_F=12$ mA, FWHM	$\Delta\lambda$			1.0	nm	
Laser Forward Voltage	$I_F=12$ mA	$V_F$	1.6	1.8	2.2	V	
Laser Reverse Voltage	$I_R=10$ $\mu\text{A}$	$BVR_{LD}$	5	10		V	
Rise and Fall Time	Bias Above Threshold (20%-80%)	$t_R$ $t_F$		150 200	300 300	ps	4
Relative Intensity Noise	1 GHz BW	RIN		-128	-122	dB/Hz	
Series Resistance	$I_F=12$ mA	$R_S$	15	25	50	Ohms	

Photodiode Parameters	Test Condition	Symbol	Min.	Typ.	Max.	Units	Notes
Monitor Current	$P_{OC}=0.35$ mW	$I_{PD}$	0.09		0.58	mA	
Monitor Current Temperature Variation	$P_{OC}=0.35$ mW	$\Delta I_{PD}/\Delta T$		0.0		%/ $^\circ\text{C}$	
Dark Current	$P_O=0$ mW, $V_R=3$ V	$I_D$			20	nA	
PD Reverse Voltage	$P_O=0$ mW, $I_R=10$ $\mu\text{A}$	$BVR_{PD}$	30	115		V	5
PD Capacitance	$V_R=0$ V, Freq=1 MHz $V_R=3$ V, Freq=1 MHz	C		75 40	100 55	pF	

#### Notes:

- Operating power is set by the peak operating current  $I_{PEAK}=I_{BIAS}+I_{MODULATION}$ .
- Operation at temperatures outside the specified range may result in the threshold current exceeding the maximums defined in the electro-optical characteristics table.
- Slope efficiency is defined as  $\Delta P_O/\Delta I_F$  at a total power output of 0.35 mW. Slope efficiency is intentionally lowered to the values shown by optical attenuation.
- Rise and fall times are sensitive to drive electronics. 200 ps rise and fall times are achievable for all Honeywell VCSELs.
- To safeguard the VCSEL from current spike damage, short the VCSEL anode and cathode to each other during photodiode BVR verification testing.

# Fiber Optic LAN Components

## LC SFF Duplex OFE 1.25 Gbps

# HFT218x-521

### RECEIVER PARAMETERS

#### **ELECTRO-OPTICAL CHARACTERISTICS (V<sub>cc</sub>=5V, 0°C<T<70°C unless otherwise specified)**

Parameters	Test Condition	Symbol	Min.	Typ.	Max.	Units	Notes
<b>Electrical Characteristics</b>							
Supply Voltage	P <sub>in</sub> = 0μW, R <sub>load</sub> =50Ω	V <sub>cc</sub>	3.0		5.5	Volts	1
Supply Current	P <sub>in</sub> = 0μW, R <sub>load</sub> =50Ω	I <sub>cc</sub>		35	40	mA	1
Output Voltage	P <sub>in</sub> = 100μW, R <sub>load</sub> =50Ω	V <sub>out</sub>		200	500	mV	1
<b>Opto-Electronic Characteristics</b>							
Responsivity	P <sub>in</sub> = 20μW peak, R <sub>load</sub> =50Ω	R	2500	3500	5000	μV/μW	2,3
Lower 3dB Bandwidth		BW <sub>lower</sub>	0.1	0.3	1	MHz	4
Upper 3dB Bandwidth		BW <sub>upper</sub>	850	1200	1500	MHz	4
RMS Output Referred Noise	P <sub>in</sub> =0μW, R <sub>load</sub> =50Ω 937.5MHz BT Filter			300		NW	5
Sensitivity	BER=10 <sup>-12</sup> , SNR=7	S	-20	-24		dBm	
Power Supply Rejection Ratio	P <sub>in</sub> =0μW, R <sub>load</sub> =50Ω	PSRR	10	30		dB	6
Pulse Width Distortion	P <sub>in</sub> =20μW peak, R <sub>load</sub> =50Ω	PWD		35	60	ps	7
Rise/Fall Time	P <sub>in</sub> =20μW peak, R <sub>load</sub> =50Ω	T <sub>R</sub> /T <sub>F</sub>			400	ps	8
Wavelength Responsivity	P <sub>in</sub> =20μW peak, R <sub>load</sub> =50Ω	λ	760	850	860	nm	

#### **Notes:**

1. Pin refers to the total optical power at the face of the fiber optic cable input to the HFD3180-002.
2. Responsivity measured with source wavelength of 850nm, 125MHz square wave, P<sub>in</sub>=20μW peak, R<sub>load</sub>=50Ω.
3. The output voltage increases as received light power increases, up to approximately -15dBm. The preamplifier is designed to limit the electrical output signal above this optical input level, and does not introduce signal distortion until the average input power exceeds 0dBm.
4. Bandwidth is measured with a small signal sinusoidal light source with 50 μW average power, R<sub>load</sub>=50Ω.
5. RMS input referred optical noise is obtained by measuring the RMS output referred noise, then dividing by the responsivity.
6. PSRR is measured from 300KHz to 1GHz by injecting a -20dB electrical signal on the V<sub>cc</sub> pin. The nominal value at 100MHz is recorded. No external bypass components are assumed. An external V<sub>cc</sub> filter network will greatly increase the PSRR.
7. Measured at the 50% level of output pulses using 0.5 GHz square wave with <200 ps rise time.
8. Rise and fall times are measured with source wavelength of 850nm, 125MHz square wave, with optical rise and fall times < 200ps, P<sub>in</sub>=20μW peak, R<sub>load</sub>=50Ω.

# Fiber Optic LAN Components

## LC SFF Duplex OFE 1.25 Gbps

# HFT218x-521

### Absolute Maximum Ratings

Parameter	Rating
Storage Temperature	-40 to +85°C
Operating Temperature	0 to +70°C
Lead Solder Temperature	260°C, 10 sec.
Continuous Optical Output Power (Any Current)	5 mW
Laser Diode Reverse Voltage ( $I_R=10 \mu A$ )	5 V
Laser Continuous Forward Current, Heat-Sinked	15 mA
PIN Photodiode Forward Current	10 mA
Power Supply Voltage (PIN + Preamp)	6 V
Incident Optical Power	0 dBm average, +4 dBm peak

### **NOTICE**

Stresses greater than those listed under “Absolute Maximum Ratings” may cause permanent damage to the device. This is a stress rating only and functional operation of the device at these or any other conditions above those indicated in the operations section for extended periods of time may affect reliability.

### **NOTICE**

The inherent design of this component causes it to be sensitive to electrostatic discharge (ESD). To prevent ESD-induced damage and/or degradation to equipment, take normal ESD precautions when handling this product

### ORDER GUIDE

Catalog Listing	Description
HFT2180-521	Attenuated, Common Anode
HFT2181-521	Attenuated, Common Cathode

# Fiber Optic LAN Components

## LC SFF Duplex OFE 1.25 Gbps

# HFT218x-521

### TYPICAL PERFORMANCE CURVES

**Emitted Power vs. Current:** Power varies approximately linearly with current above threshold.

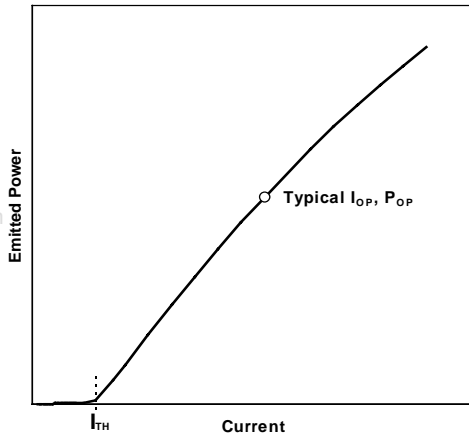

**Emission Intensity vs. Wavelength:** Typical 10 mA spectrum comprises multiple lines corresponding to multiple transverse modes.

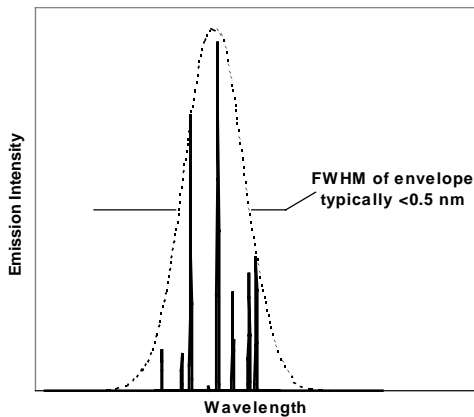

**Threshold Current vs. Temperature:** Threshold current varies parabolically with temperature; thus it can be nearly constant for a limited temperature range.

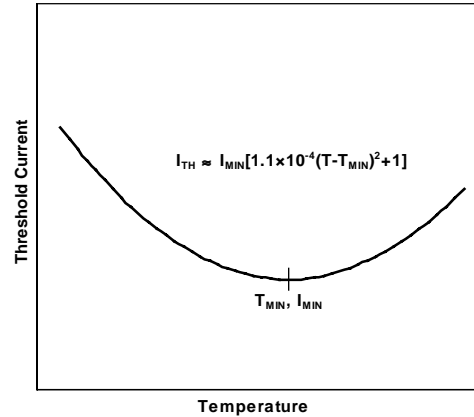

### NOTICE

The inherent design of this component causes it to be sensitive to electrostatic discharge (ESD). To prevent ESD-induced damage and/or degradation to equipment, take normal ESD precautions when handling this product.

### DANGER

The VCSEL is a class IIIb laser and should be treated as a potential eye hazard. Due to the size of the component, the applicable warning logotype, aperture label, and certification/identification label cannot be placed on the component itself. These labels can be found on the individual envelope in which the VCSEL unit is packaged, or attached to the shipping package.

# Fiber Optic LAN Components

## LC SFF Duplex OFE 1.25 Gbps

# HFT218x-521

FIGURE 1: INTERNAL SCHEMATIC DIAGRAM OF THE HFD3180-002

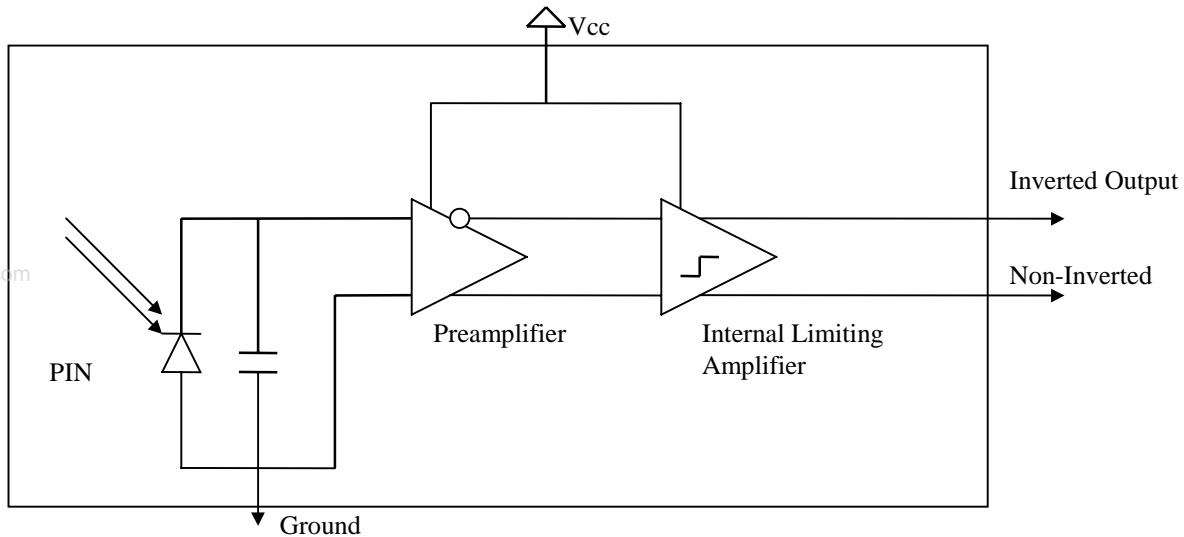
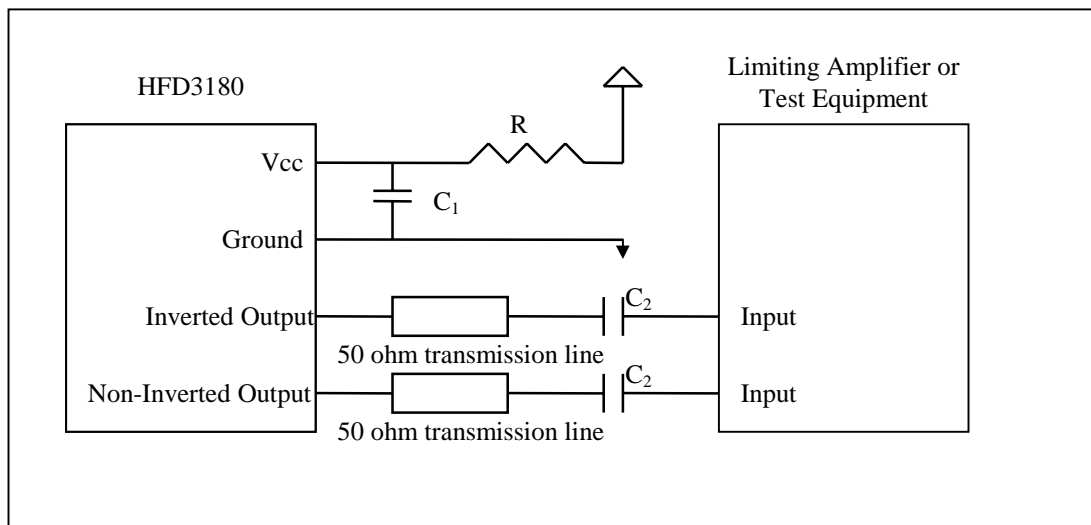

FIGURE 2: RECOMMENDED INTERFACE CIRCUIT FOR THE HFD3180-002



$R=10 \Omega$

$C_1 = 10 \text{ nF}$

$C_2 = \text{DATA RATE DEPENDANT (22NF FOR RATES > 1GB)}$

# Fiber Optic LAN Components

## LC SFF Duplex OFE 1.25 Gbps

# HFT218x-521

www.DataSheet4U.com

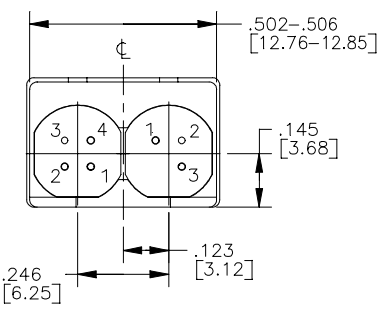
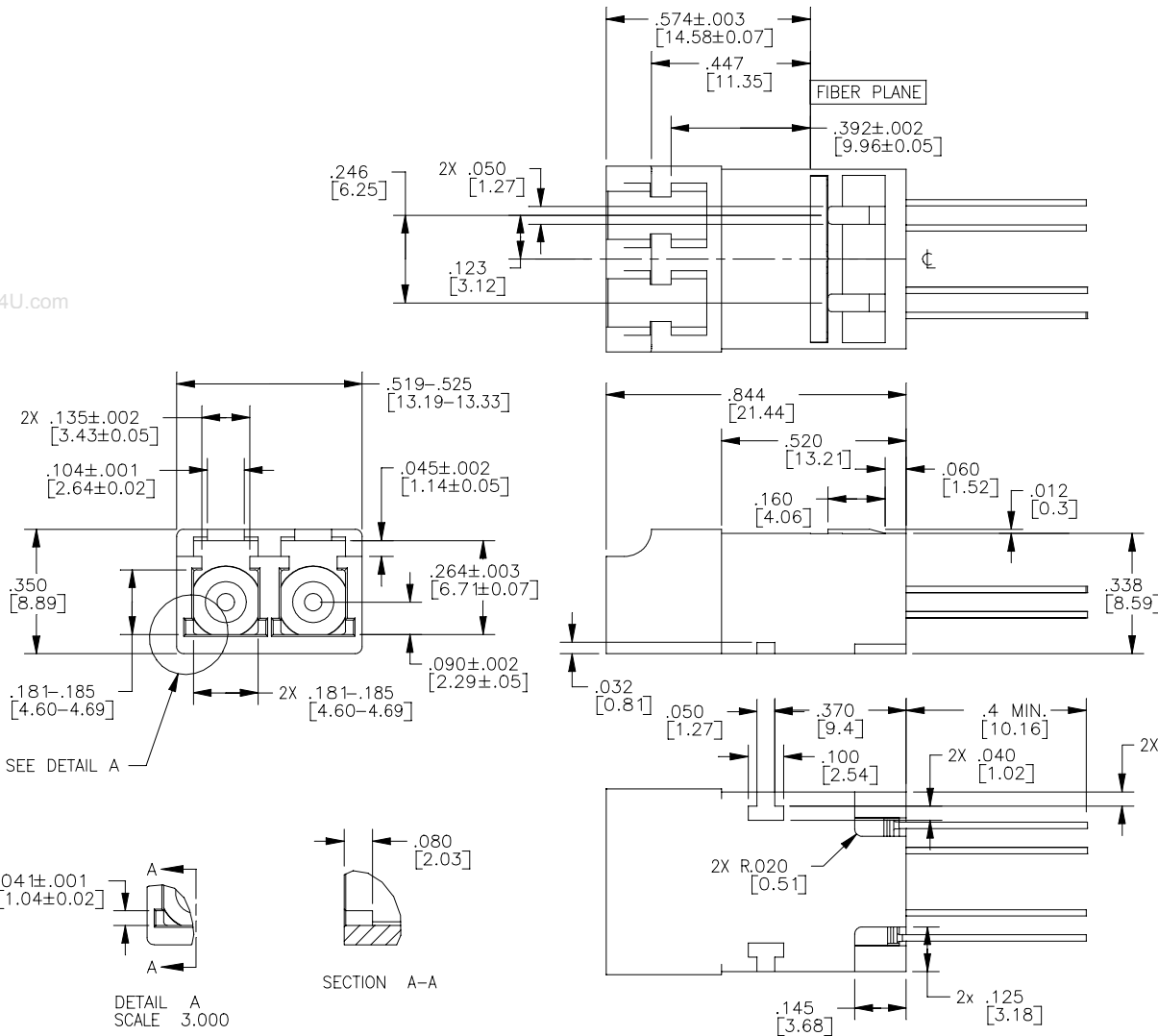
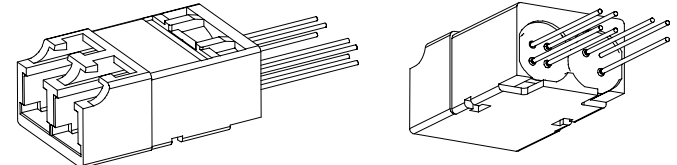

PIN #	RCVR	XMTR	
		HFT2180/HFT2190	HFT2181/HFT2191
1	Vcc	VCSEL CATH.	VCSEL ANODE
2	OUT-	VCSEL ANODE & PD CATH.	VCSEL CATH. & PD ANODE
3	GND	PD ANODE	PD CATHODE
4	OUT+	N/A	N/A

# Fiber Optic LAN Components

## LC SFF Duplex OFE 1.25 Gbps

# HFT218x-521

### WARRANTY/REMEDY

Honeywell warrants goods of its manufacture as being free of defective materials and faulty workmanship. Commencing with the date of shipment, Honeywell's warranty runs for 18 months. If warranted goods are returned to Honeywell during that period of coverage, Honeywell will repair or replace without charge those items it finds defective. The foregoing is Buyer's sole remedy and is **in lieu of all other warranties, expressed or implied, including those of merchantability and fitness for a particular purpose.**

While we provide application assistance, personally and through our literature, it is up to the customer to determine the suitability of the product in the application.

www.DataSheet4U.com

Specifications may change at any time without notice. The information we supply is believed to be accurate and reliable as of this printing. However, we assume no responsibility for its use.

### SALES AND SERVICE

Honeywell Sensing and Control serves its customers through a worldwide network of sales offices and distributors. For application assistance, current specifications, pricing or name of the nearest Authorized Distributor, contact a nearby sales office or call:

### TELEPHONE

1-800-367-6786 (USA)  
1-800-737-3360 (Canada)  
+49 (0) 89 35813310 (Germany)  
+65-580-3312 (Singapore)  
+44 (0) 118 981 9511 (UK)

### INTERNET

<http://www.honeywell.com/sensing/VCSEL>  
[info.sc@honeywell.com](mailto:info.sc@honeywell.com)

### FAX

1-972-470-4326 (Customer Response Center)  
1-972-470-4549 (Fax on demand)  
+49 (0) 89 3599971 (Germany)  
+65 445 3033 (Singapore)  
+44 (0) 118 981 7513 (UK)

7/23/01

## Honeywell

Honeywell Inc.  
11 West Spring Street  
Freeport, Illinois 61032



Printed with Soy Ink  
on 50% Recycled Paper

PK XXXX X DMM Printed in USA



Honeywell Inc.  
Optoelectronics Facility  
830 East Arapaho Road  
Richardson, Texas 75081

**Honeywell Control  
Systems Ltd.**  
Zodiac House  
Calleva Park  
Aldermaston, Berkshire  
RG7 8HW England

*Helping You Control Your World*

www.DataSheet4U.com



## Fiber Optic LAN Components LC SFF Duplex OFE 1.25 Gbps

# HFT228x-521

### FEATURES

- Prealigned Pluggable LC Duplex Optical Front End (OFE) in compliance with the SFF Pluggable Transceiver MultiSource Agreement.
- VCSEL packaged with a back monitor photodiode
- Common anode and common cathode polarities available
- TO-46 hermetic package for VCSEL and Pin + Preamp
- 5V or 3.3 V operation
- GaAs PIN detector and BiCMOS preamplifier
- Differential output for low noise
- High Speed >1GHz
- Laser signal is attenuated
- Unattenuated versions available as well (HFT2283-522 and HFT2284-522)

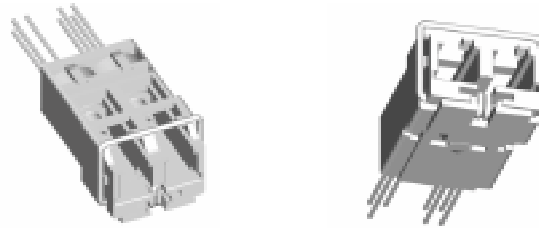

The HFT228x-52x is a single package transmitter and receiver designed to interface with the LC style optical connectors.

The transmitter is a high performance 850nm VCSEL (Vertical Cavity Surface Emitting Laser) packaged for high speed data communications. This product combines all the performance advantages of VCSEL with a custom designed power monitor diode. The power monitor diode can be used with an appropriate feedback control circuitry to set a maximum power level for each VCSEL. Attenuating coatings are available on the Laser transmitter to simplify design and assist in meeting eye safety requirements.

The PIN + preamp converts optical power into a differential output electrical signal. As the light increases, the differential output voltage increases, limiting at input powers above -10dBm. The differential output is designed to be AC coupled into a data amplifier.

The Honeywell HFT228x-521 is designed to interface with 50/125 and 62.5/125µm multimode fiber within an LC style interface.

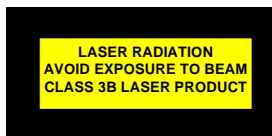

# Fiber Optic LAN Components

## LC SFF Duplex OFE 1.25 Gbps

# HFT228x-521

### VCSEL PARAMETERS

#### ELECTRO-OPTICAL CHARACTERISTICS ( $T_A=25^\circ\text{C}$ unless otherwise stated)

VCSEL Parameters	Test Condition	Symbol	Min.	Typ.	Max.	Units	Notes
Peak Fiber Coupled Optical Power (See threshold current and slope efficiency which control power output)	$I_F=12$ mA Peak 50/125 $\mu\text{m}$ fiber NA=0.20	$P_{OC}$		350 -4.5		$\mu\text{W}$ dBm	1
Threshold Current		$I_{TH}$		3.5	6	mA	
Threshold Current Temperature Variation	$T_A = 0^\circ\text{C}$ to $70^\circ\text{C}$	$\Delta I_{TH}$	-1.5		1.5	mA	2
Slope Efficiency	$P_{OC}=0.35$ mW	$\eta$	0.02	0.04	0.1	mW/mA	3
Slope Efficiency Temperature Variation	$T_A = 0^\circ\text{C}$ to $70^\circ\text{C}$	$\Delta\eta/\Delta T$		-0.5		%/ $^\circ\text{C}$	
Peak Wavelength	$I_F=12$ mA	$\lambda_P$	830	850	860	nm	
$\lambda_P$ Temp Coefficient	$I_F=12$ mA	$\Delta\lambda_P/\Delta T$		0.06		nm/ $^\circ\text{C}$	
Spectral Bandwidth	$I_F=12$ mA, FWHM	$\Delta\lambda$			1.0	nm	
Laser Forward Voltage	$I_F=12$ mA	$V_F$	1.6	1.8	2.2	V	
Laser Reverse Voltage	$I_R=10$ $\mu\text{A}$	$BVR_{LD}$	5	10		V	
Rise and Fall Time	Bias Above Threshold (20%-80%)	$t_R$ $t_F$		150 200	300 300	ps	4
Relative Intensity Noise	1 GHz BW	RIN		-128	-122	dB/Hz	
Series Resistance	$I_F=12$ mA	$R_S$	15	25	50	Ohms	

Photodiode Parameters	Test Condition	Symbol	Min.	Typ.	Max.	Units	Notes
Monitor Current	$P_{OC}=0.35$ mW	$I_{PD}$	0.09		0.58	mA	
Monitor Current Temperature Variation	$P_{OC}=0.35$ mW	$\Delta I_{PD}/\Delta T$		0.0		%/ $^\circ\text{C}$	
Dark Current	$P_O=0$ mW, $V_R=3$ V	$I_D$			20	nA	
PD Reverse Voltage	$P_O=0$ mW, $I_R=10$ $\mu\text{A}$	$BVR_{PD}$	30	115		V	5
PD Capacitance	$V_R=0$ V, Freq=1 MHz $V_R=3$ V, Freq=1 MHz	C		75 40	100 55	pF	

#### Notes:

- Operating power is set by the peak operating current  $I_{PEAK}=I_{BIAS}+I_{MODULATION}$ .
- Operation at temperatures outside the specified range may result in the threshold current exceeding the maximums defined in the electro-optical characteristics table.
- Slope efficiency is defined as  $\Delta P_O/\Delta I_F$  at a total power output of 0.35 mW. Slope efficiency is intentionally lowered to the values shown by optical attenuation.
- Rise and fall times are sensitive to drive electronics. 200 ps rise and fall times are achievable for all Honeywell VCSELs.
- To safeguard the VCSEL from current spike damage, short the VCSEL anode and cathode to each other during photodiode BVR verification testing.

# Fiber Optic LAN Components

## LC SFF Duplex OFE 1.25 Gbps

# HFT228x-521

### RECEIVER PARAMETERS

#### **ELECTRO-OPTICAL CHARACTERISTICS (V<sub>cc</sub>=5V, 0°C<T<70°C unless otherwise specified)**

Parameters	Test Condition	Symbol	Min.	Typ.	Max.	Units	Notes
<b>Electrical Characteristics</b>							
Supply Voltage	P <sub>in</sub> = 0μW, R <sub>load</sub> =50Ω	V <sub>cc</sub>	3.0		5.5	Volts	1
Supply Current	P <sub>in</sub> = 0μW, R <sub>load</sub> =50Ω	I <sub>cc</sub>		35	40	mA	1
Output Voltage	P <sub>in</sub> = 100μW, R <sub>load</sub> =50Ω	V <sub>out</sub>		200	500	mV	1
<b>Opto-Electronic Characteristics</b>							
Responsivity	P <sub>in</sub> = 20μW peak, R <sub>load</sub> =50Ω	R	2500	3500	5000	μV/μW	2,3
Lower 3dB Bandwidth		BW <sub>lower</sub>	0.1	0.3	1	MHz	4
Upper 3dB Bandwidth		BW <sub>upper</sub>	850	1200	1500	MHz	4
RMS Output Referred Noise	P <sub>in</sub> =0μW, R <sub>load</sub> =50Ω 937.5MHz BT Filter			300		NW	5
Sensitivity	BER=10 <sup>-12</sup> , SNR=7	S	-20	-24		dBm	
Power Supply Rejection Ratio	P <sub>in</sub> =0μW, R <sub>load</sub> =50Ω	PSRR	10	30		dB	6
Pulse Width Distortion	P <sub>in</sub> =20μW peak, R <sub>load</sub> =50Ω	PWD		35	60	ps	7
Rise/Fall Time	P <sub>in</sub> =20μW peak, R <sub>load</sub> =50Ω	T <sub>R</sub> /T <sub>F</sub>			400	ps	8
Wavelength Responsivity	P <sub>in</sub> =20μW peak, R <sub>load</sub> =50Ω	λ	760	850	860	nm	

#### **Notes:**

1. Pin refers to the total optical power at the face of the fiber optic cable input to the HFD3180-002.
2. Responsivity measured with source wavelength of 850nm, 125MHz square wave, P<sub>in</sub>=20μW peak, R<sub>load</sub>=50Ω.
3. The output voltage increases as received light power increases, up to approximately -15dBm. The preamplifier is designed to limit the electrical output signal above this optical input level, and does not introduce signal distortion until the average input power exceeds 0dBm.
4. Bandwidth is measured with a small signal sinusoidal light source with 50 μW average power, R<sub>load</sub>=50Ω.
5. RMS input referred optical noise is obtained by measuring the RMS output referred noise, then dividing by the responsivity.
6. PSRR is measured from 300KHz to 1GHz by injecting a -20dB electrical signal on the V<sub>cc</sub> pin. The nominal value at 100MHz is recorded. No external bypass components are assumed. An external V<sub>cc</sub> filter network will greatly increase the PSRR.
7. Measured at the 50% level of output pulses using 0.5 GHz square wave with <200 ps rise time.
8. Rise and fall times are measured with source wavelength of 850nm, 125MHz square wave, with optical rise and fall times < 200ps, P<sub>in</sub>=20μW peak, R<sub>load</sub>=50Ω.

# Fiber Optic LAN Components

## LC SFF Duplex OFE 1.25 Gbps

# HFT228x-521

### Absolute Maximum Ratings

Parameter	Rating
Storage Temperature	-40 to +85°C
Operating Temperature	0 to +70°C
Lead Solder Temperature	260°C, 10 sec.
Continuous Optical Output Power (Any Current)	5 mW
Laser Diode Reverse Voltage ( $I_R=10 \mu A$ )	5 V
Laser Continuous Forward Current, Heat-Sinked	15 mA
PIN Photodiode Forward Current	10 mA
Power Supply Voltage (PIN + Preamp)	6 V
Incident Optical Power	0 dBm average, +4 dBm peak

### **NOTICE**

Stresses greater than those listed under “Absolute Maximum Ratings” may cause permanent damage to the device. This is a stress rating only and functional operation of the device at these or any other conditions above those indicated in the operations section for extended periods of time may affect reliability.

### **NOTICE**

The inherent design of this component causes it to be sensitive to electrostatic discharge (ESD). To prevent ESD-induced damage and/or degradation to equipment, take normal ESD precautions when handling this product

### ORDER GUIDE

Catalog Listing	Description
HFT2280-521	Attenuated, Common Anode
HFT2281-521	Attenuated, Common Cathode

# Fiber Optic LAN Components

## LC SFF Duplex OFE 1.25 Gbps

# HFT228x-521

### TYPICAL PERFORMANCE CURVES

**Emitted Power vs. Current:** Power varies approximately linearly with current above threshold.

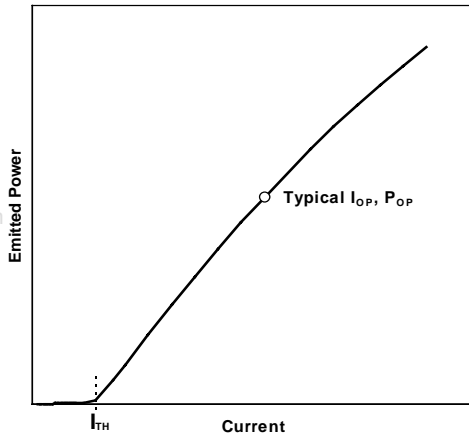

**Emission Intensity vs. Wavelength:** Typical 10 mA spectrum comprises multiple lines corresponding to multiple transverse modes.

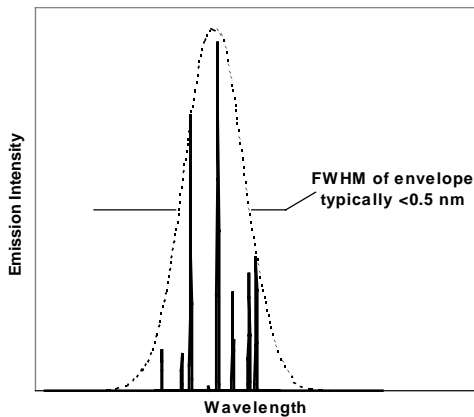

**Threshold Current vs. Temperature:** Threshold current varies parabolically with temperature; thus it can be nearly constant for a limited temperature range.

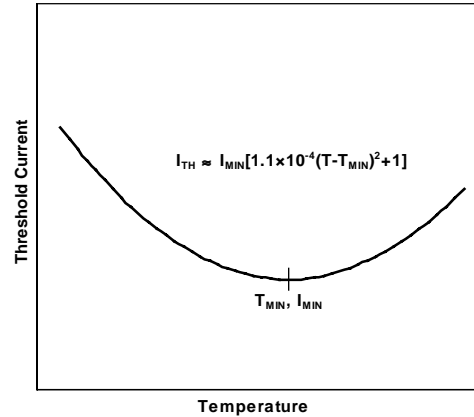

### NOTICE

The inherent design of this component causes it to be sensitive to electrostatic discharge (ESD). To prevent ESD-induced damage and/or degradation to equipment, take normal ESD precautions when handling this product.

### DANGER

The VCSEL is a class IIIb laser and should be treated as a potential eye hazard. Due to the size of the component, the applicable warning logotype, aperture label, and certification/identification label cannot be placed on the component itself. These labels can be found on the individual envelope in which the VCSEL unit is packaged, or attached to the shipping package.

# Fiber Optic LAN Components

## LC SFF Duplex OFE 1.25 Gbps

*HFT228x-521*

FIGURE 1: INTERNAL SCHEMATIC DIAGRAM OF THE HFD3180-002

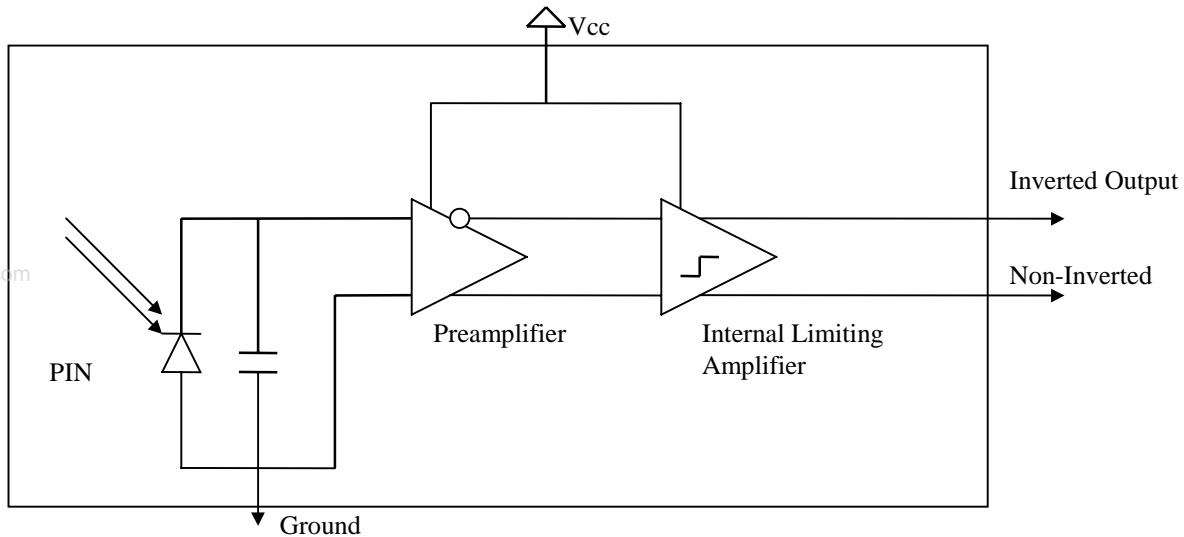
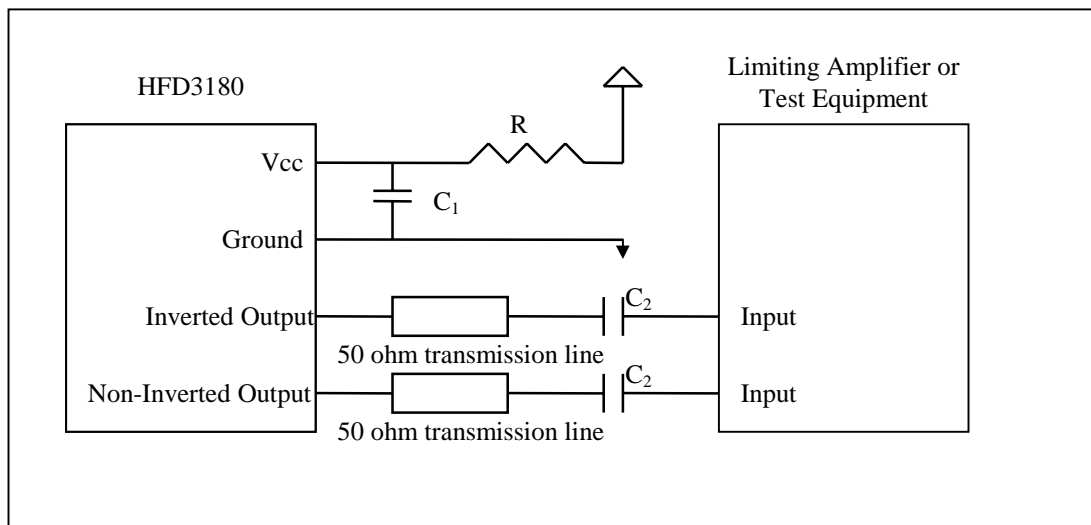

FIGURE 2: RECOMMENDED INTERFACE CIRCUIT FOR THE HFD3180-002



$R=10 \Omega$

$C_1 = 10 \text{ nF}$

$C_2 = \text{DATA RATE DEPENDANT (22NF FOR RATES > 1GB)}$

# Fiber Optic LAN Components

## LC SFF Duplex OFE 1.25 Gbps

# HFT228x-521

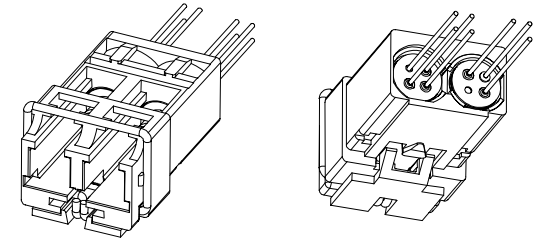
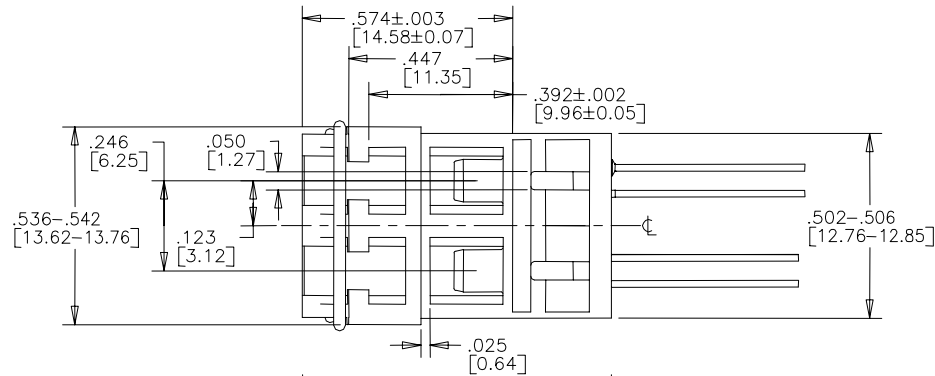

www.DataSheet4U.com

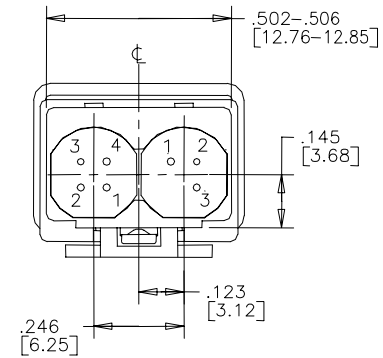
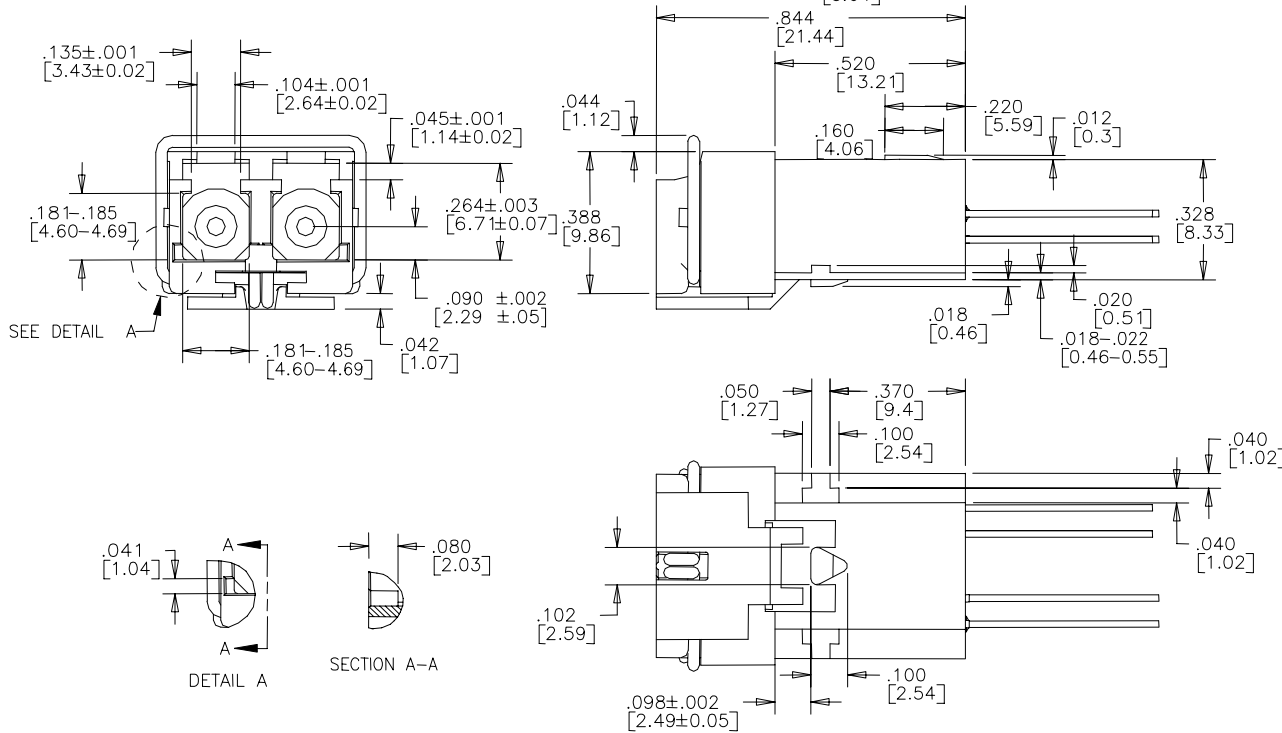

PIN #	RCVR	XMTR	
		HFT2280/2290	HFT2281/2291
1	VCC	VCSEL CATHODE	VCSEL ANODE
2	OUT-	VCSEL ANODE & PD CATH.	VCSEL CATH. & PD ANODE
3	GND	PD ANODE	PD CATHODE
4	OUT+	N/A	N/A

# Fiber Optic LAN Components

## LC SFF Duplex OFE 1.25 Gbps

# HFT228x-521

### WARRANTY/REMEDY

Honeywell warrants goods of its manufacture as being free of defective materials and faulty workmanship. Commencing with the date of shipment, Honeywell's warranty runs for 18 months. If warranted goods are returned to Honeywell during that period of coverage, Honeywell will repair or replace without charge those items it finds defective. The foregoing is Buyer's sole remedy and is **in lieu of all other warranties, expressed or implied, including those of merchantability and fitness for a particular purpose.**

While we provide application assistance, personally and through our literature, it is up to the customer to determine the suitability of the product in the application.

www.DataSheet4U.com

Specifications may change at any time without notice. The information we supply is believed to be accurate and reliable as of this printing. However, we assume no responsibility for its use.

### SALES AND SERVICE

Honeywell Sensing and Control serves its customers through a worldwide network of sales offices and distributors. For application assistance, current specifications, pricing or name of the nearest Authorized Distributor, contact a nearby sales office or call:

#### TELEPHONE

1-800-367-6786 (USA)  
1-800-737-3360 (Canada)  
+49 (0) 89 35813310 (Germany)  
+65-580-3312 (Singapore)  
+44 (0) 118 981 9511 (UK)

#### INTERNET

<http://www.honeywell.com/sensing/VCSEL>  
[info.sc@honeywell.com](mailto:info.sc@honeywell.com)

#### FAX

1-972-470-4326 (Customer Response Center)  
1-972-470-4549 (Fax on demand)  
+49 (0) 89 3599971 (Germany)  
+65 445 3033 (Singapore)  
+44 (0) 118 981 7513 (UK)

8/30/01

## Honeywell

Honeywell Inc.  
11 West Spring Street  
Freeport, Illinois 61032



Printed with Soy Ink  
on 50% Recycled Paper

PK XXXX X DMM Printed in USA



Honeywell Inc.  
Optoelectronics Facility  
830 East Arapaho Road  
Richardson, Texas 75081

**Honeywell Control  
Systems Ltd.**  
Zodiac House  
Calleva Park  
Aldermaston, Berkshire  
RG7 8HW England

*Helping You Control Your World*

www.DataSheet4U.com



## Fiber Optic LAN Components Connectorized PIN Plus Preamplifier

### *HFD3180-102*

#### FEATURES

- Prealigned LC SFF Connector sleeve
- Data rates from 622 Mbps to 2.5 Gbps
- PIN detector and preamplifier in a TO-46 hermetic package
- 3.3V operation
- GaAs PIN detector and BiCMOS preamplifier
- Differential Output for low noise
- 2.4 GHz typical Bandwidth



The HFD3180-102 is a high-performance 850nm GaAs detector and pre-amplifier packaged for high-speed data communications. The product is designed for ease of use by the module designer or manufacturer for data rates from 622 Mbps to 2.5 Gbps.

The HFD3180-102 converts optical power into an electrical signal that is used in fiber optic communications and other applications. As the light increases, the output voltage increases, limiting at input powers above  $-10\text{dBm}$ . The differential output is designed to be **AC** coupled into a data amplifier. The pre-aligned and lensed package with an industry standard LC SFF style connector sleeve, allows for "drop in" assembly to reduce manufacturing cost.

The Honeywell HFD3180-102 is designed to interface with 50/125 and 62.5/125mm multimode fiber.

# Fiber Optic LAN Components

## Connectorized PIN Plus Preamplifier

HFD3180-102

### ABSOLUTE MAXIMUM RATINGS

Parameter	Rating
Storage Temperature	-40 to +85°C
Case Operating Temperature	0 to +70°C
Lead Solder Temperature	260°C, 10 sec.
Power Supply Voltage	-0.5 to +3.8 V
Incident Optical Power	0 dBm average, +4 dBm peak

### NOTICE

Stresses greater than those listed under “Absolute Maximum Ratings” may cause permanent damage to the device. This is a stress rating only and functional operation of the device at these or any other conditions above those indicated in the operations section for extended periods of time may affect reliability.

### ELECTRO-OPTICAL CHARACTERISTICS (V<sub>cc</sub>=3.3V, AC coupled to 50Ω, 0°C<T<70°C unless otherwise specified)

Parameters	Test Condition	Symbol	Min.	Typ.	Max.	Units	Notes
<b>Electrical Characteristics</b>							
Supply Voltage	P <sub>in</sub> = 0μW, R <sub>load</sub> =50Ω	V <sub>cc</sub>	3.0	3.3	3.6	Volts	1
Supply Current	P <sub>in</sub> = 0μW, R <sub>load</sub> =50Ω	I <sub>cc</sub>		26	40	mA	1
Output Offset Voltage	P <sub>in</sub> = 0μW, R <sub>load</sub> =50Ω	V <sub>offset</sub>	-100		100	mV	9,10
Output Resistance	Single ended, freq = 0Hz	R <sub>o</sub>	40	50	62	Ω	
<b>Opto-Electronic Characteristics</b>							
Responsivity	P <sub>in</sub> < AGC <sub>th</sub> , R <sub>load</sub> =50Ω	R		1400		μV/μW	2,3,10
Differential Output Voltage	P <sub>in</sub> = 200μW, R <sub>load</sub> =50Ω, V <sub>offset</sub> = 0 mV	V <sub>out</sub>	90	160	400	mV	1
Upper 3dB Bandwidth		BW <sub>upper</sub>	1700	1900	2500	MHz	4
RMS Output Referred Noise	P <sub>in</sub> =0μW, R <sub>load</sub> =50Ω 1875 MHz BT Filter			1.5	2.25	mV	5
Sensitivity	BER=10 <sup>-12</sup> , SNR=7	S	-17	-20		dBm	
Power Supply Rejection Ratio	P <sub>in</sub> =0μW, R <sub>load</sub> =50Ω	PSRR	10	30		dB	6
Pulse Width Distortion	P <sub>in</sub> =20μW peak, R <sub>load</sub> =50Ω	PWD			40	ps	7
Rise/Fall Time	P <sub>in</sub> =20μW peak, R <sub>load</sub> =50Ω	T <sub>R</sub> /T <sub>F</sub>			250	ps	8
Wavelength Responsivity	P <sub>in</sub> =20μW peak, R <sub>load</sub> =50Ω	λ	760	850	860	nm	
AGC <sub>th</sub> threshold power	V <sub>offset</sub> = 0mV, Pin = Peak power	AGC <sub>th</sub>		60		μW	9,10

### Notes:

- Pin refers to the peak optical power at the face of the fiber optic cable input to the HFD3180-102.
- Responsivity measured with source wavelength of 850nm, freq = 0Hz, P<sub>in</sub>< AGC<sub>th</sub>, R<sub>load</sub>=50Ω, sample tested at 2.5Gbps
- The output voltage increases as received light power increases, up to approximately -15dBm depending upon the AGC<sub>th</sub>. The preamplifier is designed to limit the electrical output signal above this optical input level, and does not introduce signal distortion until the average input power exceeds 0dBm.
- Bandwidth is measured with a small signal sinusoidal light source with 50 μW average power, R<sub>load</sub>=50Ω.
- RMS input referred optical noise is sample tested by measuring the RMS output referred noise, then dividing by the responsivity.
- PSRR is sample tested from 300KHz to 1GHz by injecting a -20dB electrical signal on the V<sub>cc</sub> pin. The nominal value at 100MHz is recorded. No external bypass components are assumed. An external V<sub>cc</sub> filter network will greatly increase the PSRR.
- Sample tested at the 50% level of output pulses.
- Rise and fall times are sample tested with source wavelength of 850nm, 125MHz square wave, with optical rise and fall times < 200ps, P<sub>in</sub>< AGC<sub>th</sub>, R<sub>load</sub>=50Ω. Measured at 20% - 80% signal levels
- Output offset voltage is defined as V<sub>out</sub> - V<sub>outQ</sub> with no light
- The AGC<sub>th</sub> power depends on the offset voltage. Refer to fig 3.

### NOTICE

The inherent design of this component causes it to be sensitive to electrostatic discharge (ESD). To prevent ESD-induced damage and/or degradation to equipment, take normal ESD precautions when handling this product

# Fiber Optic LAN Components

## Connectorized PIN Plus Preamplifier

HFD3180-102

FIGURE 1: INTERNAL SCHEMATIC DIAGRAM OF THE HFD3180-102

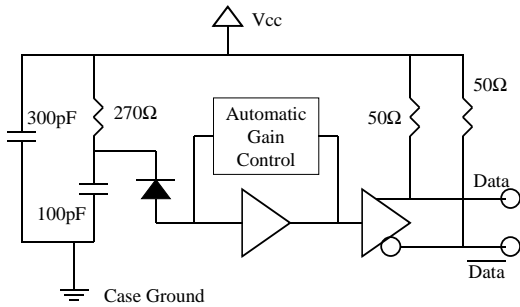

www.DataSheet4U.com

FIGURE 2: RECOMMENDED INTERFACE CIRCUIT FOR THE HFD3180-102

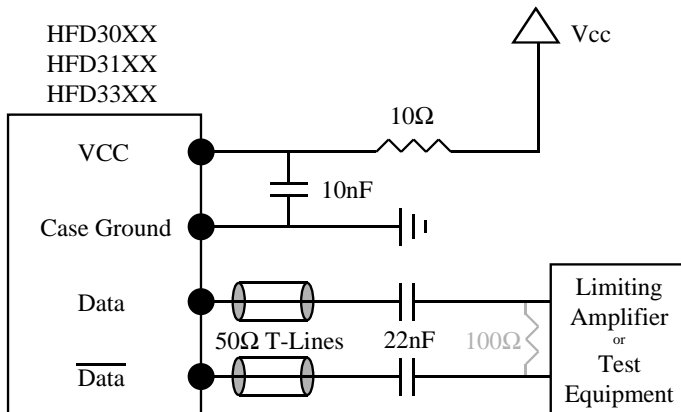

Note: 100Ω terminating resistor is optional

R=10 Ω

C<sub>1</sub> = 10 nF

C<sub>2</sub> = Data rate dependant (22nF for rates > 1Gbps)

FIGURE 3: AGC THRESHOLD POWER VS. OUTPUT OFFSET VOLTAGE

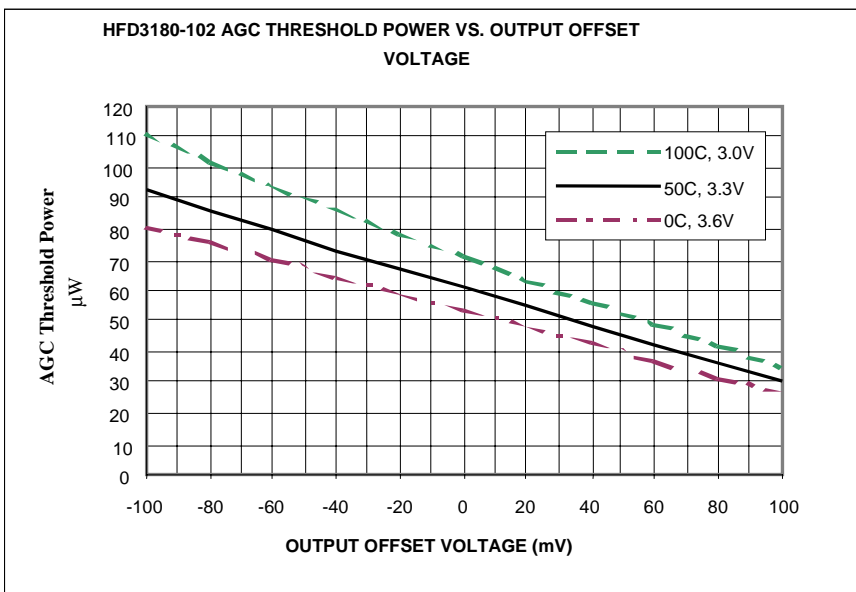

# Fiber Optic LAN Components

## Connectorized PIN Plus Preamplifier

# HFD3180-102

### ORDER GUIDE

Catalog Listing	Description
HFD3180-102	Connectorized PIN Plus Preamplifier

### MOUNTING DIMENSIONS (for reference only) in./(mm)

#### CURRENT DIMENSIONS

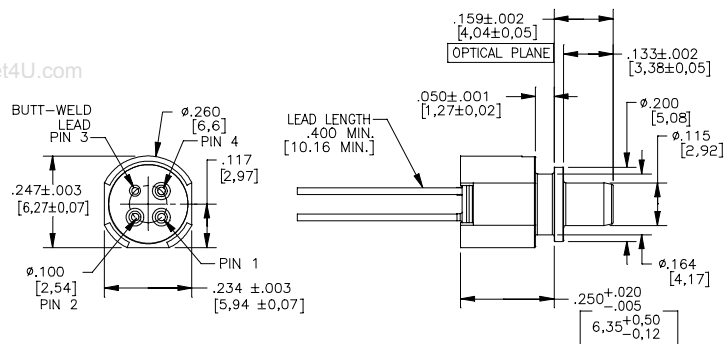

### PINOUT

Number	Function
1	V <sub>CC</sub>
2	Inverted Output (VoutQ)
3	Ground
4	Non Inverted Output (Vout)

### WARRANTY/REMEDY

Honeywell warrants goods of its manufacture as being free of defective materials and faulty workmanship. Commencing with the date of shipment, Honeywell's warranty runs for 18 months. If warranted goods are returned to Honeywell during that period of coverage, Honeywell will repair or replace without charge those items it finds defective. The foregoing is Buyer's sole remedy and is **in lieu of all other warranties, expressed or implied, including those of merchantability and fitness for a particular purpose.**

While we provide application assistance, personally and through our literature, it is up to the customer to determine the suitability of the product in the application.

Specifications may change at any time without notice. The information we supply is believed to be accurate and reliable as of this printing. However, we assume no responsibility for its use.

### SALES AND SERVICE

Honeywell Sensing and Control serves its customers through a worldwide network of sales offices and distributors. For application assistance, current specifications, pricing or name of the nearest Authorized Distributor, contact a nearby sales office or call:

### TELEPHONE

1-800-367-6786 (USA)  
 1-800-737-3360 (Canada)  
 +49 (0) 89 35813310 (Germany)  
 +65-580-3312 (Singapore)  
 +44 (0) 118 981 9511 (UK)

### FAX

1-972-470-4326 (Customer Response Center)  
 1-972-470-4549 (Fax on demand)  
 +49 (0) 89 3599971 (Germany)  
 +65 445 3033 (Singapore)  
 +44 (0) 118 981 7513 (UK)

### INTERNET

<http://www.honeywell.com/VCSEL>  
[VCSEL@HONEYWELL.COM](mailto:VCSEL@HONEYWELL.COM)

02/01/02

# Honeywell

Honeywell Inc.  
 11 West Spring Street  
 Freeport, Illinois 61032



Honeywell Inc.  
 Optoelectronics Facility  
 830 East Arapaho Road  
 Richardson, Texas 75081

**Honeywell Control Systems Ltd.**  
 Zodiac House  
 Calleva Park  
 Aldermaston, Berkshire  
 RG7 8HW England

*Helping You Control Your World*

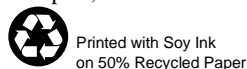

006697-1-EN IL50 GLO 797 Printed in USA

[www.DataSheet4U.com](http://www.DataSheet4U.com)

# Fiber Optic LAN Components Connectorized PIN Plus Preamplifier

Preliminary  
HFD3180-102

Future Dimension (available starting late February 2002)

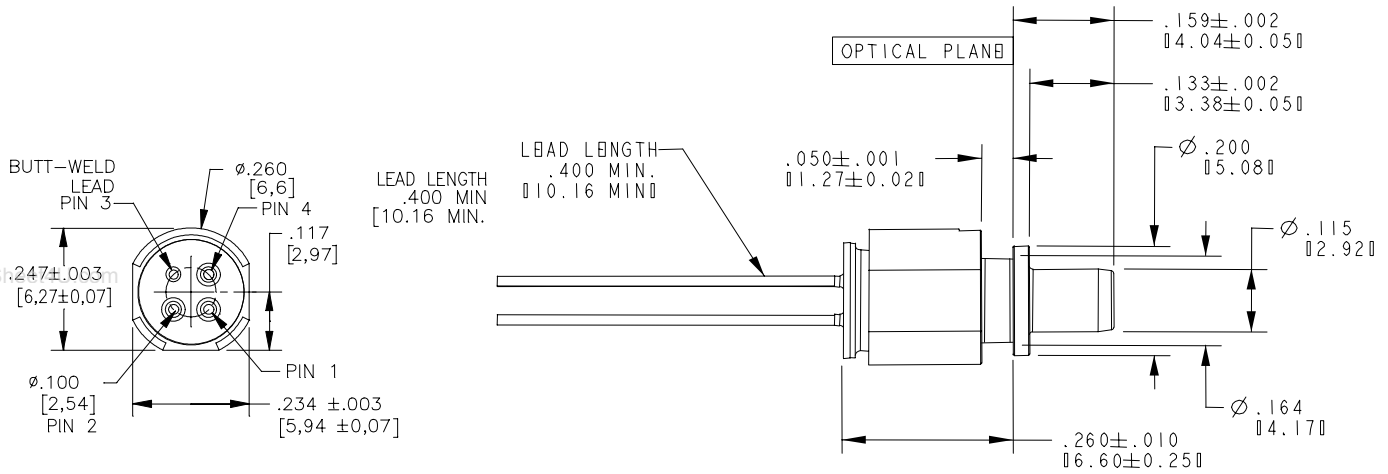

**Honeywell**

Honeywell Inc.  
11 West Spring Street  
Freeport, Illinois 61032



Honeywell Inc.  
Optoelectronics Facility  
830 East Arapaho Road  
Richardson, Texas 75081

**Honeywell Control  
Systems Ltd.**  
Zodiac House  
Calleva Park  
Aldermaston, Berkshire  
RG7 8HW England

*Helping You Control Your World*

[www.DataSheet4U.com](http://www.DataSheet4U.com)

PK XXXX X DMM Printed in USA

## Fiber Optic LAN Components Connectorized PIN Plus Preamplifier

# HFD3381-102

### FEATURES

- Prealigned SC Connector sleeve
- Data rates from 622 Mbps to 2.5 Gbps
- PIN detector and preamplifier in a TO-46 hermetic package
- 3.3V operation
- GaAs PIN detector and BiCMOS preamplifier
- Differential Output for low noise
- 2.4 GHz typical Bandwidth



The HFD3381-102 is a high-performance 850nm GaAs detector and pre-amplifier packaged for high-speed data communications. The product is designed for ease of use by the module designer or manufacturer for data rates from 622 Mbps to 2.5 Gbps.

The HFD3381-102 converts optical power into an electrical signal that is used in fiber optic communications and other applications. As the light increases, the output voltage increases, limiting at input powers above  $-10\text{dBm}$ . The differential output is designed to be AC coupled into a data amplifier. The pre-aligned and lensed package with an industry standard SC style connector sleeve, allows for "drop in" assembly to reduce manufacturing cost.

The Honeywell HFD3381-102 is designed to interface with 50/125 and 62.5/125mm multimode fiber.

# Fiber Optic LAN Components

## Connectorized PIN Plus Preamplifier

HFD3381-102

### ABSOLUTE MAXIMUM RATINGS

Parameter	Rating
Storage Temperature	-40 to +85°C
Case Operating Temperature	0 to +70°C
Lead Solder Temperature	260°C, 10 sec.
Power Supply Voltage	-0.5 to +3.8 V
Incident Optical Power	0 dBm average, +4 dBm peak

### NOTICE

Stresses greater than those listed under “Absolute Maximum Ratings” may cause permanent damage to the device. This is a stress rating only and functional operation of the device at these or any other conditions above those indicated in the operations section for extended periods of time may affect reliability.

### ELECTRO-OPTICAL CHARACTERISTICS (V<sub>cc</sub>=3.3V, AC coupled to 50Ω, 0°C<T<70°C unless otherwise specified)

Parameters	Test Condition	Symbol	Min.	Typ.	Max.	Units	Notes
<b>Electrical Characteristics</b>							
Supply Voltage	P <sub>in</sub> = 0μW, R <sub>load</sub> =50Ω	V <sub>cc</sub>	3.0	3.3	3.6	Volts	1
Supply Current	P <sub>in</sub> = 0μW, R <sub>load</sub> =50Ω	I <sub>cc</sub>		26	40	mA	1
Output Offset Voltage	P <sub>in</sub> = 0μW, R <sub>load</sub> =50Ω	V <sub>offset</sub>	-100		100	mV	9,10
Output Resistance	Single ended, freq = 0Hz	R <sub>o</sub>	40	50	62	Ω	
<b>Opto-Electronic Characteristics</b>							
Responsivity	P <sub>in</sub> < AGC <sub>th</sub> , R <sub>load</sub> =50Ω	R		1400		μV/μW	2,3,10
Differential Output Voltage	P <sub>in</sub> = 200μW, R <sub>load</sub> =50Ω, V <sub>offset</sub> = 0 mV	V <sub>out</sub>	90	160	400	mV	1
Upper 3dB Bandwidth		BW <sub>upper</sub>	1700	1900	2500	MHz	4
RMS Output Referred Noise	P <sub>in</sub> =0μW, R <sub>load</sub> =50Ω 1875 MHz BT Filter			1.5	2.25	mV	5
Sensitivity	BER=10 <sup>-12</sup> , SNR=7	S	-17	-20		dBm	
Power Supply Rejection Ratio	P <sub>in</sub> =0μW, R <sub>load</sub> =50Ω	PSRR	10	30		dB	6
Pulse Width Distortion	P <sub>in</sub> =20μW peak, R <sub>load</sub> =50Ω	PWD			40	ps	7
Rise/Fall Time	P <sub>in</sub> =20μW peak, R <sub>load</sub> =50Ω	T <sub>R</sub> /T <sub>F</sub>			250	ps	8
Wavelength Responsivity	P <sub>in</sub> =20μW peak, R <sub>load</sub> =50Ω	λ	760	850	860	nm	
AGC <sub>th</sub> threshold power	V <sub>offset</sub> = 0mV, Pin = Peak power	AGC <sub>th</sub>		60		μW	9,10

### Notes:

- Pin refers to the peak optical power at the face of the fiber optic cable input to the HFD3381-102.
- Responsivity measured with source wavelength of 850nm, freq = 0Hz, P<sub>in</sub>< AGC<sub>th</sub>, R<sub>load</sub>=50Ω, sample tested at 2.5Gbps
- The output voltage increases as received light power increases, up to approximately -15dBm depending upon the AGC<sub>th</sub>. The preamplifier is designed to limit the electrical output signal above this optical input level, and does not introduce signal distortion until the average input power exceeds 0dBm.
- Bandwidth is measured with a small signal sinusoidal light source with 50 μW average power, R<sub>load</sub>=50Ω.
- RMS input referred optical noise is sample tested by measuring the RMS output referred noise, then dividing by the responsivity.
- PSRR is sample tested from 300KHz to 1GHz by injecting a -20dB electrical signal on the V<sub>cc</sub> pin. The nominal value at 100MHz is recorded. No external bypass components are assumed. An external V<sub>cc</sub> filter network will greatly increase the PSRR.
- Sample tested at the 50% level of output pulses.
- Rise and fall times are sample tested with source wavelength of 850nm, 125MHz square wave, with optical rise and fall times < 200ps, P<sub>in</sub>< AGC<sub>th</sub>, R<sub>load</sub>=50Ω. Measured at 20% - 80% signal levels
- Output offset voltage is defined as V<sub>out</sub> - V<sub>outQ</sub> with no light
- The AGC<sub>th</sub> power depends on the offset voltage. Refer to fig 3.

### NOTICE

The inherent design of this component causes it to be sensitive to electrostatic discharge (ESD). To prevent ESD-induced damage and/or degradation to equipment, take normal ESD precautions when handling this product

# Fiber Optic LAN Components

## Connectorized PIN Plus Preamplifier

HFD3381-102

FIGURE 1: INTERNAL SCHEMATIC DIAGRAM OF THE HFD3381-102

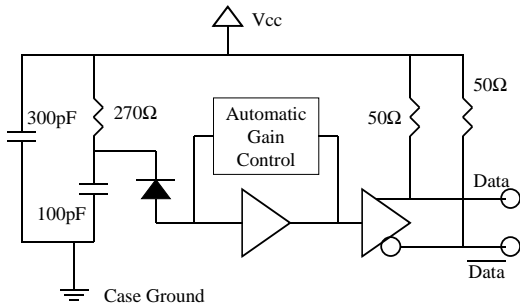
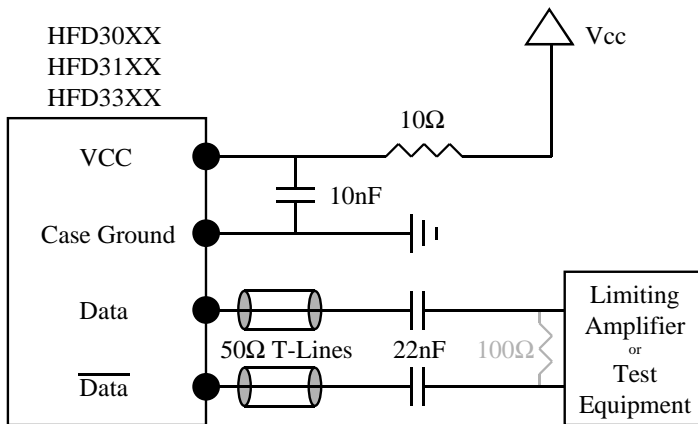

FIGURE 2: RECOMMENDED INTERFACE CIRCUIT FOR THE HFD3381-102



Note: 100Ω terminating resistor is optional

R=10 Ω

C<sub>1</sub> = 10 nF

C<sub>2</sub> = Data rate dependant (22nF for rates > 1Gbps)

FIGURE 3: AGC THRESHOLD POWER VS. OUTPUT OFFSET VOLTAGE

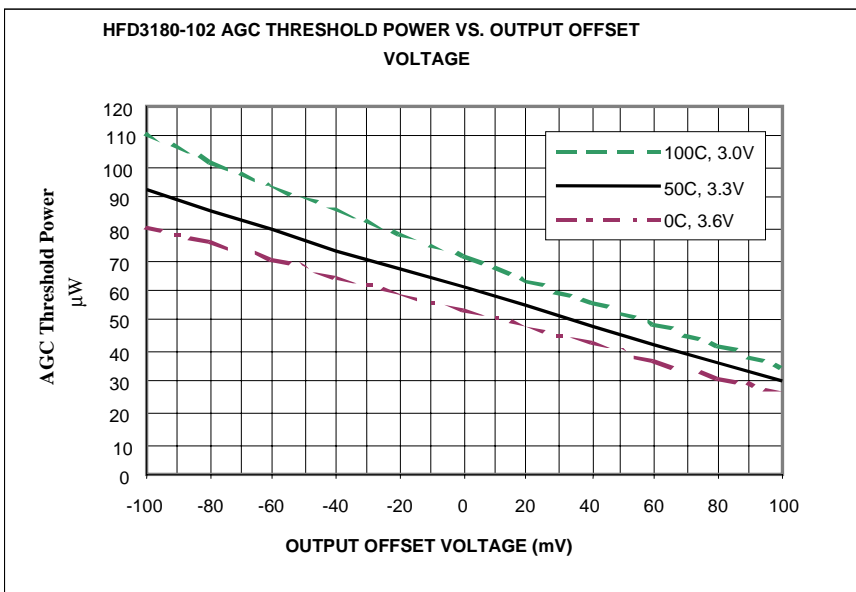



# Fiber Optic LAN Components

## Connectorized PIN Plus Preamplifier

# HFD3381-102

### ORDER GUIDE

Catalog Listing	Description
HFD3381-102	Connectorized PIN Plus Preamplifier

### MOUNTING DIMENSIONS (for reference only) in./.(mm)

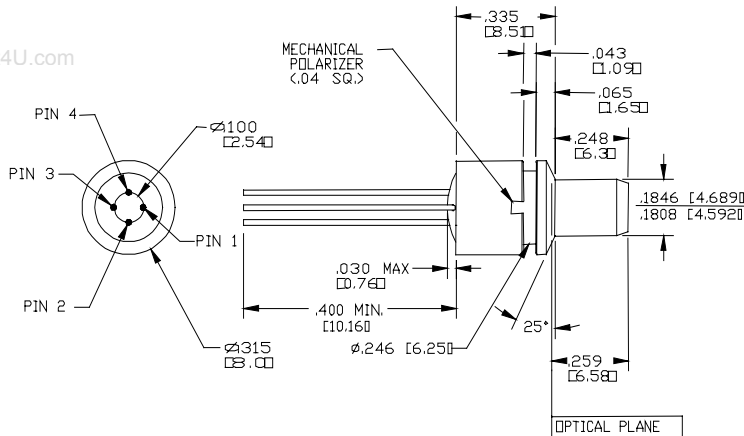

### PINOUT

Number	Function
1 *	V <sub>CC</sub>
2	Inverted Output
3	Ground
4	Non Inverted Output

- \* Aligned with the Receptacle notch
- \* VCC is cut shorter

### WARRANTY/REMEDY

Honeywell warrants goods of its manufacture as being free of defective materials and faulty workmanship. Commencing with the date of shipment, Honeywell's warranty runs for 18 months. If warranted goods are returned to Honeywell during that period of coverage, Honeywell will repair or replace without charge those items it finds defective. The foregoing is Buyer's sole remedy and is **in lieu of all other warranties, expressed or implied, including those of merchantability and fitness for a particular purpose.**

While we provide application assistance, personally and through our literature, it is up to the customer to determine the suitability of the product in the application.

01/31/02

# Honeywell

Honeywell Inc.  
11 West Spring Street  
Freeport, Illinois 61032



Honeywell Inc.  
Optoelectronics Facility  
830 East Arapaho Road  
Richardson, Texas 75081

**Honeywell Control Systems Ltd.**  
Zodiac House  
Calleva Park  
Aldermaston, Berkshire  
RG7 8HW England

*Helping You Control Your World*

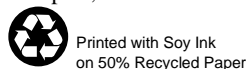

006697-1-EN IL50 GLO 797 Printed in USA

[www.DataSheet4U.com](http://www.DataSheet4U.com)

## Fiber Optic LAN Components PIN Plus Preamplifier

*Preliminary*  
**HFD3041-102**

### FEATURES

- TO-46 hermetic package
- Data rates from DC to 2.5Gbps  
InGaAs PIN detector and  
BiCMOS preamplifier
- Operation at 3.3V
- Differential output for low noise
- 2.3GHz typical Bandwidth

www.DataSheet4U.com

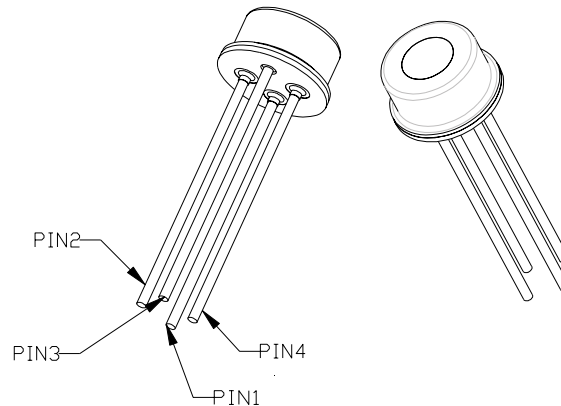

The HFD3041-102 is a high-performance 1300nm integrated InGaAs detector (80micron active area) and pre-amplifier TO-46 hermetic component, the product is designed for ease of use in modules designed for 2.5GB/s data rate.

The HFD3041-102 converts optical power into a differential output electrical signal that is used in fiber optic communications and other applications. As the light increases, the differential output voltage increases. Above peak optical powers of approximately  $-12\text{dBm}$ , AGC circuitry in the TIA limits the optical voltage swings. The differential output is designed to be AC coupled to a 50 ohm load impedance pulled down to ground prior to any post amplification stages. The component requires alignment in a lens system which focuses the light onto the photodiode active area.

To achieve the full specified operational bandwidth, it is recommended that the products component leads at attached to within 0.10" of the receptacle with a controlled impedance path.

The Honeywell HFD3041-102 is designed to interface with 50/125 and 62.5/125mm multimode fiber.

# Fiber Optic LAN Components

## PIN Plus Preamplifier

Preliminary  
HFD3041-102

### ABSOLUTE MAXIMUM RATINGS

Parameter	Rating
Storage Temperature	-40 to +85°C
Case Operating Temperature	-40 to +85°C
Lead Solder Temperature	260°C, 10 sec.
Power Supply Voltage	-0.5V to 3.8V
Incident Optical Power	0 dBm average, +4 dBm peak

### NOTICE

Stresses greater than those listed under “Absolute Maximum Ratings” may cause permanent damage to the device. This is a stress rating only and functional operation of the device at these or any other conditions above those indicated in the operations section for extended periods of time may affect reliability.

### ELECTRO-OPTICAL CHARACTERISTICS (V<sub>cc</sub>=3.3V, AC coupled to 50Ω, 0°C<T<70°C unless otherwise specified)

Parameters	Test Condition	Symbol	Min.	Typ.	Max.	Units	Notes
Active Area				80		μm	
Input Optical Wavelength	0°C to 70°C	λ <sub>p</sub>	1200	1310	1600	nm	
Responsivity	P <sub>R</sub> < AGC <sub>th</sub> , -40°C to +85°C PD active area is 80um dia.	R	1.3	2.7	4.2	mV/μW	1,2,7
Differential Output Voltage Swing	P <sub>R</sub> = -7dBm, AC Coupled to R <sub>L</sub> =50Ω	V <sub>o(pk-pk)</sub>	0.10	0.20		V	
Supply Current	P <sub>R</sub> =0μW peak, R <sub>L</sub> =50Ω	ICC		25	40	mA	1
-3dB Optical/Electrical Bandwidth	P <sub>R</sub> =-12dBm Temp = 25°C	BW	1.6	1.8	2.5	GHz	1,3
Low Frequency -3dB Cutoff	P <sub>R</sub> =-12dBm	BW <sub>LF</sub>			0	KHz	1,3
RMS Input Referred Noise Equivalent Power	1875 MHz, 4-pole BT Filter, P <sub>R</sub> =0uW (Dark)	NEP		0.50	0.65	μW	4
Power Supply Rejection Ratio	P <sub>R</sub> =0μW (Dark), Freq = 100MHz	PSRR		30		dB	1,8
Pulse Width Distortion	P <sub>R</sub> =-12dBm	PWD			60	ps	1,5
Rise/Fall Time	P <sub>R</sub> =-12dBm, (20%-80%)	T <sub>R</sub> /T <sub>F</sub>	105	150	170	ps	1,6,7
AGC Threshold Power	Peak Optical Power Output	AGC <sub>th</sub>		65		μW	9

### Notes:

- P<sub>R</sub> is the average optical power incident on the component window, subject to note 7.
- Responsivity measured with source wavelength of 1310nm, with light source modulated at 250MHz. Peak received optical power <AGC<sub>th</sub>
- Bandwidth is measured with a small signal sinusoidal light source with -12dBm average power
- RMS input referred optical noise equivalent power is obtained by measuring the RMS output noise into an 1875 MHz, 4-pole Bessel-Thompson filter then dividing by the responsivity.
- Measured at the 50% level of output pulses.
- Rise/Fall times are corrected for optical source Rise/Fall times. The corrected value is calculated as the square root of the difference of the squares of the measured differential detector output and the source.
- Unless otherwise stated, all output parameters are measured differentially using an optical lens which focuses the optical power within a spot diameter smaller than the photodiode active area. Customers results will depend on the optical lens system used. Component leads are shorter than 0.1inch in length.
- Value shown is with no external power supply filtering. Improved performance can be obtained by using external filtering close to the power supply leads.
- The AGC threshold power is the peak received optical power. At lower power, the receiver operates in its linear responsivity characteristic region. Above AGC threshold, the output voltage is relatively independent of the optical input power.
- Typical values represent measured data at 25°C.

### NOTICE

The inherent design of this component causes it to be sensitive to electrostatic discharge (ESD). To prevent ESD-induced damage and/or degradation to equipment, take normal ESD precautions when handling this product

# Fiber Optic LAN Components

## PIN Plus Preamplifier

Preliminary  
HFD3041-102

FIGURE 1: INTERNAL SCHEMATIC DIAGRAM OF THE HFD3381-102

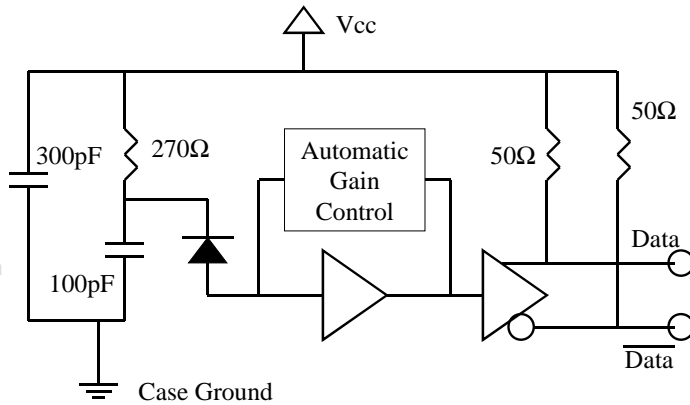
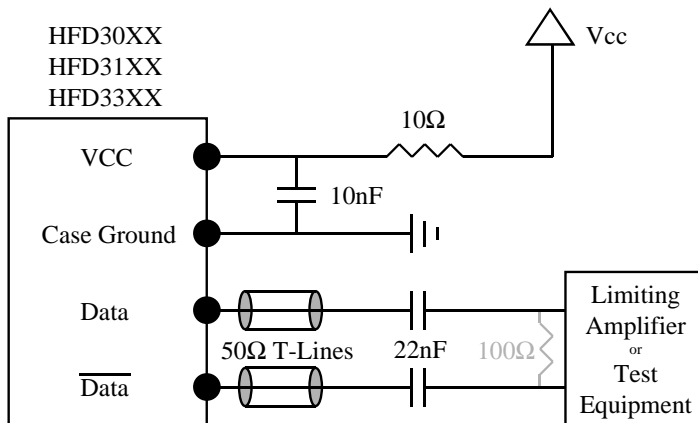

FIGURE 2: RECOMMENDED INTERFACE CIRCUIT FOR THE HFD3381-102



Note: 100Ω terminating resistor is optional

$$R=10\ \Omega$$

$$C_1 = 10\ \text{nF}$$

$$C_2 = \text{Data rate dependant (22nF for rates } > 1\text{Gbps)}$$

# Fiber Optic LAN Components PIN Plus Preamplifier

*Preliminary*  
**HFD3041-102**

## ORDER GUIDE

Catalog Listing	Description
HFD3041-102	PIN Plus Preamplifier, TO-46 Component

## MOUNTING DIMENSIONS (for reference only) in./(mm)

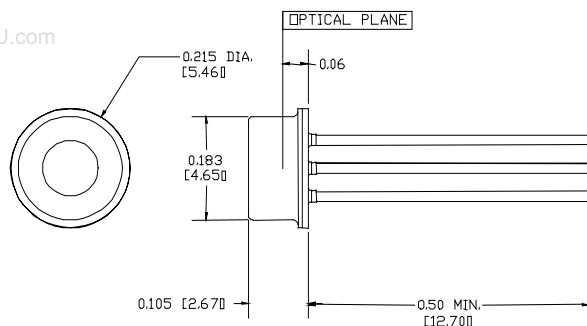

## PINOUT

Number	Function
1	V <sub>CC</sub>
2	Inverted Output
3	Ground
4	Non-Inverted Output

## WARRANTY/REMEDY

Honeywell warrants goods of its manufacture as being free of defective materials and faulty workmanship. Commencing with the date of shipment, Honeywell's warranty runs for 18 months. If warranted goods are returned to Honeywell during that period of coverage, Honeywell will repair or replace without charge those items it finds defective. The foregoing is Buyer's sole remedy and is **in lieu of all other warranties, expressed or implied, including those of merchantability and fitness for a particular purpose.**

While we provide application assistance, personally and through our literature, it is up to the customer to determine the suitability of the product in the application.

Specifications may change at any time without notice. The information we supply is believed to be accurate and reliable as of this printing. However, we assume no responsibility for its use.

Preliminary

03/07/02

**Honeywell**

## SALES AND SERVICE

MICRO SWITCH Sensing and Control serves its customers through a worldwide network of sales offices and distributors. For application assistance, current specifications, pricing or name of the nearest Authorized Distributor, contact a nearby sales office or call:

## TELEPHONE

1-800-367-6786 (USA)  
1-800-737-3360 (Canada)  
+49 (0) 89 35813310 (Germany)  
+65-580-3312 (Singapore)  
+44 (0) 118 981 9511 (UK)

## FAX

1-972-470-4326 (Customer Response Center)  
1-972-470-4549 (Fax on demand)  
+49 (0) 89 3599971 (Germany)  
+65 445 3033 (Singapore)  
+44 (0) 118 981 7513 (UK)

## INTERNET

<http://www.honeywell.com/VCSEL>  
[vcsel@honeywell.com](mailto:vcsel@honeywell.com)

**VCSEL Products**  
Honeywell Inc.  
11 West Spring Street  
Freeport, Illinois 61032



**VCSEL Products**  
Honeywell Inc.  
Optoelectronics Facility  
830 East Arapaho Road  
Richardson, Texas 75081

**Honeywell Control Systems Ltd.**  
Zodiac House  
Calleva Park  
Aldermaston, Berkshire  
RG7 8HW England

*Helping You Control Your World*

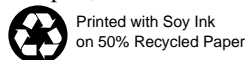

006697-1-EN IL50 GLO 797 Printed in USA

[www.DataSheet4U.com](http://www.DataSheet4U.com)

## Fiber Optic LAN Components PIN Plus Preamplifier

*Preliminary*  
**HFD3041-103**

### FEATURES

- TO-46 hermetic package
- Data rates from DC to 2.5 Gbps
- InGaAs PIN detector and BiCMOS preamplifier
- Operation at 3.3V
- Differential output for low noise
- 2.3GHz typical Bandwidth

www.DataSheet4U.com

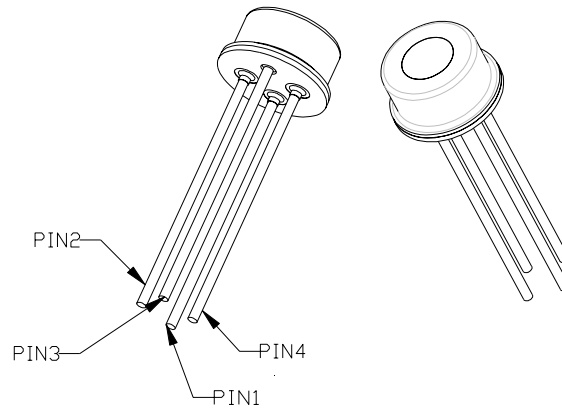

The HFD3041-103 is a high-performance 1300nm integrated InGaAs detector (40micron active area) and pre-amplifier TO-46 hermetic component, the product is designed for ease of use in modules designed for 2.5GB/s data rate.

The HFD3041-103 converts optical power into a differential output electrical signal that is used in fiber optic communications and other applications. As the light increases, the differential output voltage increases. Above peak optical powers of approximately  $-11.5\text{dBm}$ , AGC circuitry in the TIA limits the optical voltage swings. The differential output is designed to be AC coupled to a 50 ohm load impedance pulled down to ground prior to any post amplification stages. The component requires alignment in a lens system which focuses the light onto the photodiode active area.

To achieve the full specified operational bandwidth, it is recommended that the products component leads be attached to within 0.10" of the receptacle with a controlled impedance path.

The Honeywell HFD3041-103 is designed to interface with single mode fiber.

# Fiber Optic LAN Components

## PIN Plus Preamplifier

Preliminary  
HFD3041-103

### ABSOLUTE MAXIMUM RATINGS

Parameter	Rating
Storage Temperature	-40 to +85°C
Case Operating Temperature	-40 to +85°C
Lead Solder Temperature	260°C, 10 sec.
Power Supply Voltage	-0.5V to 3.8V
Incident Optical Power	0 dBm average, +4 dBm peak

### NOTICE

Stresses greater than those listed under “Absolute Maximum Ratings” may cause permanent damage to the device. This is a stress rating only and functional operation of the device at these or any other conditions above those indicated in the operations section for extended periods of time may affect reliability.

### ELECTRO-OPTICAL CHARACTERISTICS (V<sub>cc</sub>=3.3V, AC coupled to 50Ω, 0°C<T<70°C unless otherwise specified)

Parameters	Test Condition	Symbol	Min.	Typ.	Max.	Units	Notes
Active Area				40		μm	
Input Optical Wavelength	0°C to 70°C	λ <sub>p</sub>	1200	1310	1600	nm	
Responsivity	P <sub>R</sub> < AGC <sub>th</sub> , -40°C to +85°C PD active area is 40um dia.	R	1.3	2.7	4.2	mV/μW	1,2,7
Differential Output Voltage Swing	P <sub>R</sub> = -7dBm , AC Coupled to R <sub>L</sub> =50Ω	V <sub>o(pk-pk)</sub>	0.10	0.20		V	
Supply Current	P <sub>R</sub> =0μW peak, R <sub>L</sub> =50Ω	ICC		25	40	mA	1
-3dB Optical/Electrical Bandwidth	P <sub>R</sub> =-12dBm Temp = 25°C	BW	1.6	2.0	2.5	GHz	1,3
Low Frequency -3dB Cutoff	P <sub>R</sub> =-12dBm	BW <sub>LF</sub>			0	KHz	1,3
RMS Input Referred Noise Equivalent Power	1875 MHz, 4-pole BT Filter, P <sub>R</sub> =0uW (Dark)	NEP		0.50	0.65	μW	4
Power Supply Rejection Ratio	P <sub>R</sub> =0μW (Dark), Freq = 100MHz	PSRR		30		dB	1,8
Pulse Width Distortion	P <sub>R</sub> =-12dBm	PWD			60	ps	1,5
Rise/Fall Time	P <sub>R</sub> =-12dBm, (20%-80%)	T <sub>R</sub> /T <sub>F</sub>	105	130	170	ps	1,6,7
AGC Threshold Power	Peak Optical Power Input	AGC <sub>th</sub>		70		μW	9

### Notes:

- P<sub>R</sub> is the average optical power incident on the component window, subject to note 7.
- Responsivity measured with source wavelength of 1310nm, with light source modulated at 250MHz. Peak received optical power <AGC<sub>th</sub>
- Bandwidth is measured with a small signal sinusoidal light source with -12dBm average power.
- RMS input referred optical noise equivalent power is obtained by measuring the RMS output noise into an 1875 MHz, 4-pole Bessel-Thompson filter then dividing by the DC responsivity.
- Measured at the 50% level of output pulses
- Rise/Fall times are corrected for optical source Rise/Fall times. The corrected value is calculated as the square root of the difference of the squares of the measured differential detector output and the source.
- Unless otherwise stated, all output parameters are measured differentially using an optical lens which focuses the optical power within a spot diameter smaller than the photodiode active area. Customers' results will depend on the optical lens system used. Component leads are shorter than 0.1inch in length.
- Value shown is with no external power supply filtering. Improved performance can be obtained by using external filtering close to the power supply leads.
- The AGC threshold power is the peak received optical power. At lower power, the receiver operates in its linear responsivity characteristic region. Above AGC threshold, the output voltage is relatively independent of the optical input power.
- Typical values represent measured data at 25°C.

### NOTICE

The inherent design of this component causes it to be sensitive to electrostatic discharge (ESD). To prevent ESD-induced damage and/or degradation to equipment, take normal ESD precautions when handling this product

# Fiber Optic LAN Components

## PIN Plus Preamplifier

Preliminary  
HFD3041-103

FIGURE 1: INTERNAL SCHEMATIC DIAGRAM OF THE HFD3381-102

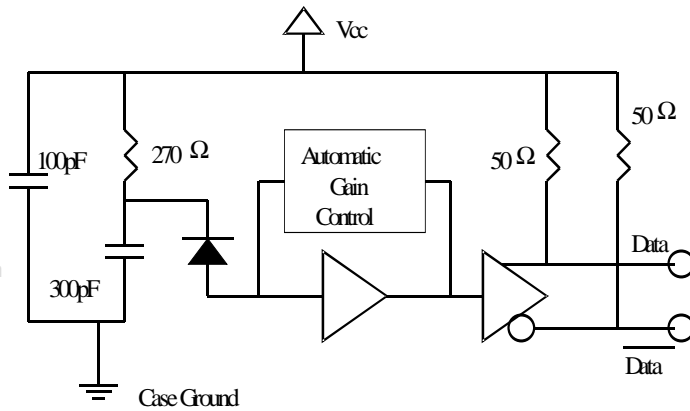
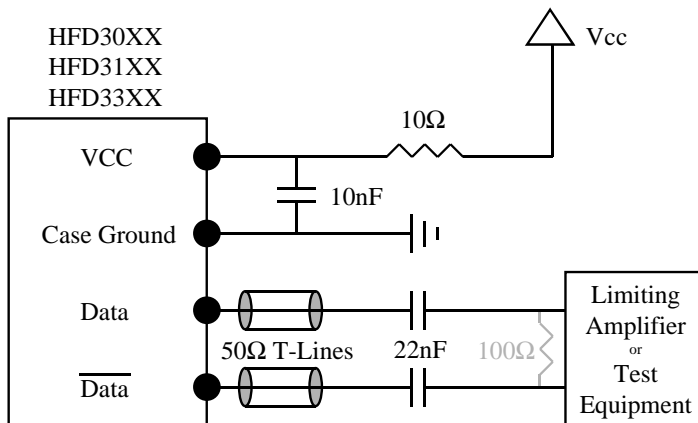

FIGURE 2: RECOMMENDED INTERFACE CIRCUIT FOR THE HFD3381-102



Note: 100Ω terminating resistor is optional

$$R=10\ \Omega$$

$$C_1 = 10\ \text{nF}$$

$$C_2 = \text{Data rate dependant (22nF for rates } > 1\text{Gbps)}$$



# Fiber Optic LAN Components PIN Plus Preamplifier

*Preliminary*  
**HFD3041-103**

## ORDER GUIDE

Catalog Listing	Description
HFD3041-103	PIN Plus Preamplifier, TO-46 Component

## MOUNTING DIMENSIONS (for reference only) in./(mm)

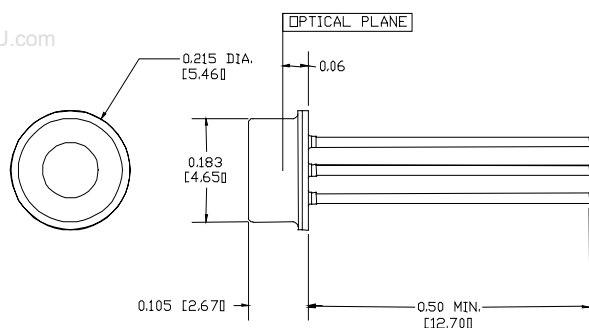

## PINOUT

Number	Function
1	V <sub>CC</sub>
2	Inverted Output
3	Ground
4	Non-Inverted Output

## WARRANTY/REMEDY

Honeywell warrants goods of its manufacture as being free of defective materials and faulty workmanship. Commencing with the date of shipment, Honeywell's warranty runs for 18 months. If warranted goods are returned to Honeywell during that period of coverage, Honeywell will repair or replace without charge those items it finds defective. The foregoing is Buyer's sole remedy and is **in lieu of all other warranties, expressed or implied, including those of merchantability and fitness for a particular purpose.**

While we provide application assistance, personally and through our literature, it is up to the customer to determine the suitability of the product in the application.

Specifications may change at any time without notice. The information we supply is believed to be accurate and reliable as of this printing. However, we assume no responsibility for its use.

Preliminary

03/07/02

**Honeywell**

## SALES AND SERVICE

MICRO SWITCH Sensing and Control serves its customers through a worldwide network of sales offices and distributors. For application assistance, current specifications, pricing or name of the nearest Authorized Distributor, contact a nearby sales office or call:

## TELEPHONE

1-800-367-6786 (USA)  
1-800-737-3360 (Canada)  
+49 (0) 89 35813310 (Germany)  
+65-580-3312 (Singapore)  
+44 (0) 118 981 9511 (UK)

## FAX

1-972-470-4326 (Customer Response Center)  
1-972-470-4549 (Fax on demand)  
+49 (0) 89 3599971 (Germany)  
+65 445 3033 (Singapore)  
+44 (0) 118 981 7513 (UK)

## INTERNET

<http://www.honeywell.com/VCSEL>  
[vcsel@honeywell.com](mailto:vcsel@honeywell.com)

**VCSEL Products**  
Honeywell Inc.  
11 West Spring Street  
Freeport, Illinois 61032



**VCSEL Products**  
Honeywell Inc.  
Optoelectronics Facility  
830 East Arapaho Road  
Richardson, Texas 75081

**Honeywell Control Systems Ltd.**  
Zodiac House  
Calleva Park  
Aldermaston, Berkshire  
RG7 8HW England

*Helping You Control Your World*

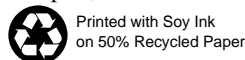

006697-1-EN IL50 GLO 797 Printed in USA

[www.DataSheet4U.com](http://www.DataSheet4U.com)

## Fiber Optic LAN Components PIN Plus Preamplifier

*Preliminary*  
**HFD3141-102**

### FEATURES

- Pre-aligned LC SFF Connector sleeve
- PIN detector and preamplifier in a TO-46 hermetic package
- Data rates from DC to 2.5 Gbps
- InGaAs PIN detector and BiCMOS preamplifier
- Operation at 3.3V
- Differential output for low noise



The HFD3141-102 is a high-performance 1300nm integrated InGaAs detector (80micron active area) and pre-amplifier in a pre-aligned LC SFF connector for single mode applications. The product is designed for ease of use in modules designed for 2.5GB/s data rate.

The HFD3141-102 converts optical power into a differential output electrical signal that is used in fiber optic communications and other applications. As the light increases, the differential output voltage increases. Above peak optical powers of approximately  $-11.5\text{dBm}$ , AGC circuitry in the TIA limits the optical voltage swings. The differential output is designed to be AC coupled to a 50 ohm load impedance pulled down to ground prior to any post amplification stages.

To achieve the full-specified operational bandwidth, it is recommended that the products component leads at attached to within 0.10" of the receptacle with a controlled impedance path.

The Honeywell HFD3141-102 is designed to interface with single mode fiber.

# Fiber Optic LAN Components

## PIN Plus Preamplifier

Preliminary  
HFD3141-102

### ABSOLUTE MAXIMUM RATINGS

Parameter	Rating
Storage Temperature	-40 to +85°C
Case Operating Temperature	-40 to +85°C
Lead Solder Temperature	260°C, 10 sec.
Power Supply Voltage	-0.5V to 3.8V
Incident Optical Power	0 dBm average, +4 dBm peak

### NOTICE

Stresses greater than those listed under “Absolute Maximum Ratings” may cause permanent damage to the device. This is a stress rating only and functional operation of the device at these or any other conditions above those indicated in the operations section for extended periods of time may affect reliability.

### ELECTRO-OPTICAL CHARACTERISTICS (V<sub>cc</sub>=3.3V, AC coupled to 50Ω, 0°C<T<70°C unless otherwise specified)

Parameters	Test Condition	Symbol	Min.	Typ.	Max.	Units	Notes
Active Area				80		μm	
Input Optical Wavelength	0°C to 70°C	λ <sub>p</sub>	1200	1310	1600	nm	1
Responsivity	P <sub>R</sub> < AGC <sub>th</sub> , -40°C to +85°C PD active area is 80um dia.	R	1.1	2.3	3.8	mV/μW	1,2
Differential Output Voltage Swing	P <sub>R</sub> = -7dBm , AC Coupled to R <sub>L</sub> =50Ω	V <sub>o(pk-pk)</sub>	0.10	0.20		V	
Supply Current	P <sub>R</sub> =0μW peak, R <sub>L</sub> =50Ω	ICC		25	40	mA	1
-3dB Optical/Electrical Bandwidth	P <sub>R</sub> =-12dBm Temp = 25°C	BW	1.6	1.8	2.5	GHz	1,3
Low Frequency -3dB Cutoff	P <sub>R</sub> =-12dBm	BW <sub>LF</sub>			0	KHz	1,3
RMS Input Referred Noise Equivalent Power	1875 MHz, 4-pole BT Filter, P <sub>R</sub> =0uW (Dark)	NEP		0.50	0.65	μW	4
Power Supply Rejection Ratio	P <sub>R</sub> =0μW (Dark), Freq = 100MHz	PSRR		30		dB	1,7
Sensitivity	BER = 10 <sup>-12</sup> , MM Fiber		-22.5			dB	
Pulse Width Distortion	P <sub>R</sub> =-12dBm	PWD			60	ps	1,5
Rise/Fall Time	P <sub>R</sub> =-12dBm, (20%-80%)	T <sub>R</sub> /T <sub>F</sub>	105	130	170	ps	1,6
AGC Threshold Power	Peak Optical Power Input	AGC <sub>th</sub>		75		μW	8

### Notes:

- P<sub>R</sub> is the average optical power incident on the receptacle.
- Responsivity measured with source wavelength of 1310nm, with light source modulated at 250MHz. Peak received optical power <AGC<sub>th</sub>
- Bandwidth is measured with a small signal sinusoidal light source with -12dBm average power.
- RMS input referred optical noise equivalent power is obtained by measuring the RMS output noise into an 1875 MHz, 4-pole Bessel-Thompson filter then dividing by the DC responsivity.
- Measured at the 50% level of output pulses
- Rise/Fall times are corrected for optical source Rise/Fall times. The corrected value is calculated as the square root of the difference of the squares of the measured differential detector output and the source.
- Value shown is with no external power supply filtering. Improved performance can be obtained by using external filtering close to the power supply leads.
- The AGC threshold power is the peak received optical power. At lower power, the receiver operates in its linear responsivity characteristic region. Above AGC threshold, the output voltage is relatively independent of the optical input power.
- Typical values represent measured data at 25°C.

### NOTICE

The inherent design of this component causes it to be sensitive to electrostatic discharge (ESD). To prevent ESD-induced damage and/or degradation to equipment, take normal ESD precautions when handling this product

# Fiber Optic LAN Components

## PIN Plus Preamplifier

Preliminary  
HFD3141-102

FIGURE 1: INTERNAL SCHEMATIC DIAGRAM OF THE HFD3141-102

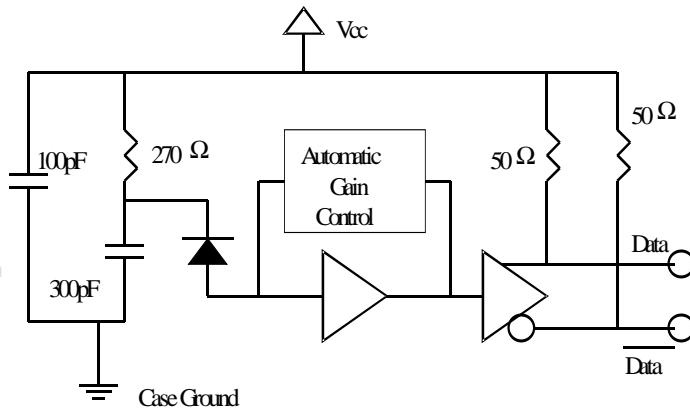
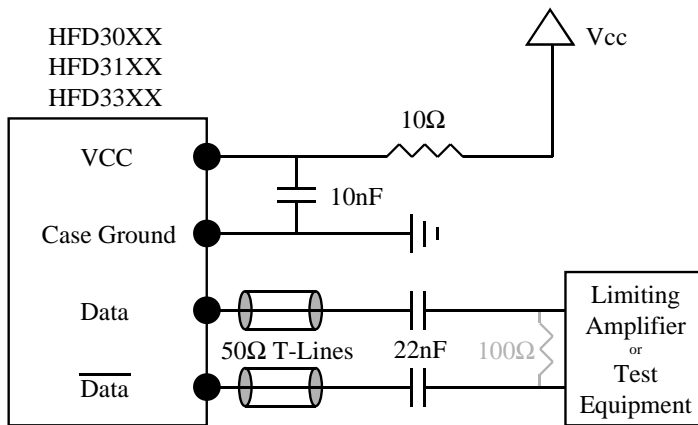

FIGURE 2: RECOMMENDED INTERFACE CIRCUIT FOR THE HFD3141-102



Note: 100Ω terminating resistor is optional

$$R=10 \Omega$$

$$C_1 = 10 \text{ nF}$$

$$C_2 = \text{Data rate dependant (22nF for rates } > 1\text{Gbps)}$$

# Fiber Optic LAN Components

## PIN Plus Preamplifier

Preliminary  
HFD3141-102

### ORDER GUIDE

Catalog Listing	Description
HFD3141-102	PIN Plus Preamplifier, LC connectorized

### MOUNTING DIMENSIONS (for reference only) in./(mm)

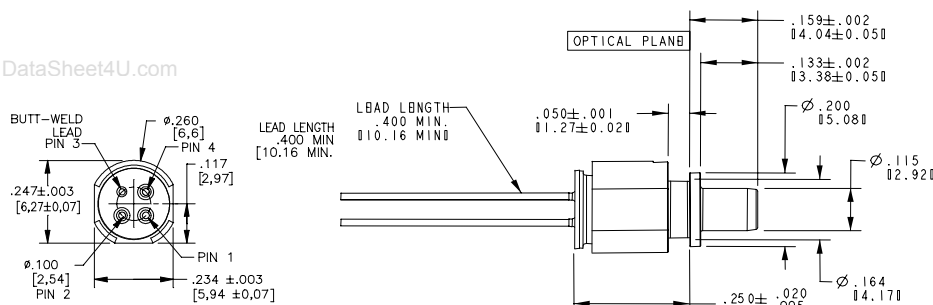

### PINOUT

Number	Function
1	V <sub>CC</sub>
2	Inverted Output
3	Ground
4	Non-Inverted Output

### WARRANTY/REMEDY

Honeywell warrants goods of its manufacture as being free of defective materials and faulty workmanship. Commencing with the date of shipment, Honeywell's warranty runs for 18 months. If warranted goods are returned to Honeywell during that period of coverage, Honeywell will repair or replace without charge those items it finds defective. The foregoing is Buyer's sole remedy and is **in lieu of all other warranties, expressed or implied, including those of merchantability and fitness for a particular purpose.**

While we provide application assistance, personally and through our literature, it is up to the customer to determine the suitability of the product in the application.

Specifications may change at any time without notice. The information we supply is believed to be accurate and reliable as of this printing. However, we assume no responsibility for its use.

### SALES AND SERVICE

MICRO SWITCH Sensing and Control serves its customers through a worldwide network of sales offices and distributors. For application assistance, current specifications, pricing or name of the nearest Authorized Distributor, contact a nearby sales office or call:

### TELEPHONE

1-800-367-6786 (USA)  
1-800-737-3360 (Canada)  
+49 (0) 89 35813310 (Germany)  
+65-580-3312 (Singapore)  
+44 (0) 118 981 9511 (UK)

### FAX

1-972-470-4326 (Customer Response Center)  
1-972-470-4549 (Fax on demand)  
+49 (0) 89 3599971 (Germany)  
+65 445 3033 (Singapore)  
+44 (0) 118 981 7513 (UK)

### INTERNET

<http://www.honeywell.com/VCSEL>  
[vcsel@honeywell.com](mailto:vcsel@honeywell.com)

Preliminary

05/10/02

**Honeywell**

**VCSEL Products**  
Honeywell Inc.  
11 West Spring Street  
Freeport, Illinois 61032



**VCSEL Products**  
Honeywell Inc.  
Optoelectronics Facility  
830 East Arapaho Road  
Richardson, Texas 75081

**Honeywell Control Systems Ltd.**  
Zodiac House  
Calleva Park  
Aldermaston, Berkshire  
RG7 8HW England

*Helping You Control Your World*

Printed with Soy Ink  
on 50% Recycled Paper

006697-1-EN IL50 GLO 797 Printed in USA

[www.DataSheet4U.com](http://www.DataSheet4U.com)

## Fiber Optic LAN Components PIN Plus Preamplifier

*Preliminary*  
**HFD3141-103**

### FEATURES

- Pre-aligned LC SFF Connector sleeve
- PIN detector and preamplifier in a TO-46 hermetic package
- Data rates from DC to 2.5 Gbps
- InGaAs PIN detector and BiCMOS preamplifier
- Operation at 3.3V
- Differential output for low noise
- 2.3GHz typical Bandwidth



The HFD3141-103 is a high-performance 1300nm integrated InGaAs detector (40micron active area) and pre-amplifier in a pre-aligned LC SFF connector for single mode applications. The product is designed for ease of use in modules designed for 2.5GB/s data rate.

The HFD3141-103 converts optical power into a differential output electrical signal that is used in fiber optic communications and other applications. As the light increases, the differential output voltage increases. Above peak optical powers of approximately  $-11.5\text{dBm}$ , AGC circuitry in the TIA limits the optical voltage swings. The differential output is designed to be AC coupled to a 50 ohm load impedance pulled down to ground prior to any post amplification stages.

To achieve the full-specified operational bandwidth, it is recommended that the products component leads at attached to within 0.10" of the receptacle with a controlled impedance path.

The Honeywell HFD3141-103 is designed to interface with single mode fiber.

# Fiber Optic LAN Components

## PIN Plus Preamplifier

Preliminary  
HFD3141-103

### ABSOLUTE MAXIMUM RATINGS

Parameter	Rating
Storage Temperature	-40 to +85°C
Case Operating Temperature	-40 to +85°C
Lead Solder Temperature	260°C, 10 sec.
Power Supply Voltage	-0.5V to 3.8V
Incident Optical Power	0 dBm average, +4 dBm peak

### NOTICE

Stresses greater than those listed under “Absolute Maximum Ratings” may cause permanent damage to the device. This is a stress rating only and functional operation of the device at these or any other conditions above those indicated in the operations section for extended periods of time may affect reliability.

### ELECTRO-OPTICAL CHARACTERISTICS (V<sub>CC</sub>=3.3V, AC coupled to 50Ω, 0°C<T<70°C unless otherwise specified)

Parameters	Test Condition	Symbol	Min.	Typ.	Max.	Units	Notes
Active Area				40		μm	
Input Optical Wavelength	0°C to 70°C	λ <sub>p</sub>	1200	1310	1600	nm	1
Responsivity	P <sub>R</sub> < AGC <sub>th</sub> , -40°C to +85°C PD active area is 40um dia.	R	1.1	2.3	3.8	mV/μW	1,2
Differential Output Voltage Swing	P <sub>R</sub> = -7dBm , AC Coupled to R <sub>L</sub> =50Ω	V <sub>o(pk-pk)</sub>	0.10	0.20		V	
Supply Current	P <sub>R</sub> =0μW peak, R <sub>L</sub> =50Ω	ICC		25	40	mA	1
-3dB Optical/Electrical Bandwidth	P <sub>R</sub> =-12dBm Temp = 25°C	BW	1.6	2.0	2.5	GHz	1,3
Low Frequency -3dB Cutoff	P <sub>R</sub> =-12dBm	BW <sub>LF</sub>			0	KHz	1,3
RMS Input Referred Noise Equivalent Power	1875 MHz, 4-pole BT Filter, P <sub>R</sub> =0uW (Dark)	NEP		0.50	0.65	μW	4
Power Supply Rejection Ratio	P <sub>R</sub> =0μW (Dark), Freq = 100MHz	PSRR		30		dB	1,7
Sensitivity	BER = 10 <sup>-12</sup> , SM Fiber		-22.5			dB	10
Pulse Width Distortion	P <sub>R</sub> =-12dBm	PWD			60	ps	1,5
Rise/Fall Time	P <sub>R</sub> =-12dBm, (20%-80%)	T <sub>R</sub> /T <sub>F</sub>	105	130	170	ps	1,6
AGC Threshold Power	Peak Optical Power Input	AGC <sub>th</sub>		75		μW	8

### Notes:

- P<sub>R</sub> is the average optical power incident on the receptacle.
- Responsivity measured with source wavelength of 1310nm, with light source modulated at 250MHz. Peak received optical power <AGC<sub>th</sub>
- Bandwidth is measured with a small signal sinusoidal light source with -12dBm average power.
- RMS input referred optical noise equivalent power is obtained by measuring the RMS output noise into an 1875 MHz, 4-pole Bessel-Thompson filter then dividing by the DC responsivity.
- Measured at the 50% level of output pulses
- Rise/Fall times are corrected for optical source Rise/Fall times. The corrected value is calculated as the square root of the difference of the squares of the measured differential detector output and the source.
- Value shown is with no external power supply filtering. Improved performance can be obtained by using external filtering close to the power supply leads.
- The AGC threshold power is the peak received optical power. At lower power, the receiver operates in its linear responsivity

characteristic region. Above AGC threshold, the output voltage is relatively independent of the optical input power.

- Typical values represent measured data at 25°C.
- Sensitivity is reduced by about 1dB for MM fiber.

### NOTICE

The inherent design of this component causes it to be sensitive to electrostatic discharge (ESD). To prevent ESD-induced damage and/or degradation to equipment, take normal ESD precautions when handling this product

# Fiber Optic LAN Components

## PIN Plus Preamplifier

Preliminary  
HFD3141-103

FIGURE 1: INTERNAL SCHEMATIC DIAGRAM OF THE HFD3141-103

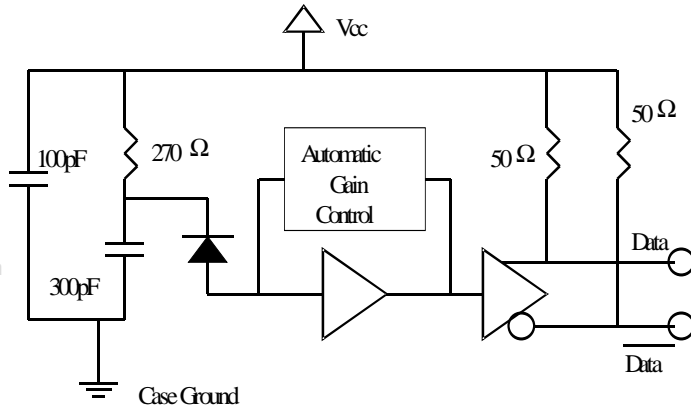
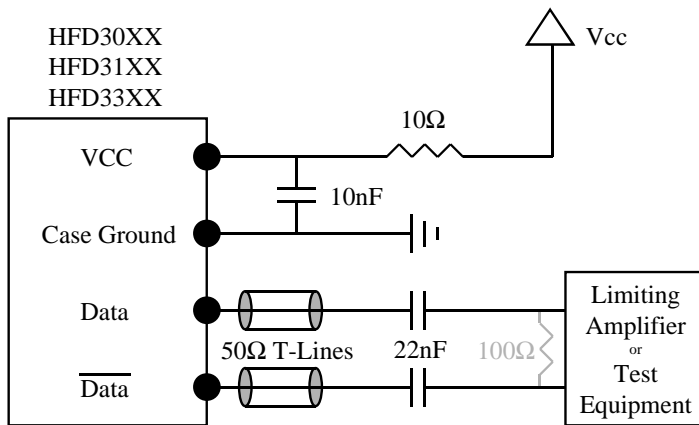

FIGURE 2: RECOMMENDED INTERFACE CIRCUIT FOR THE HFD3141-103



Note: 100Ω terminating resistor is optional

$$R=10 \Omega$$

$$C_1 = 10 \text{ nF}$$

$$C_2 = \text{Data rate dependant (22nF for rates } > 1\text{Gbps)}$$



# Fiber Optic LAN Components

## PIN Plus Preamplifier

*Preliminary*  
**HFD3141-103**

### ORDER GUIDE

Catalog Listing	Description
HFD3141-103	PIN Plus Preamplifier, LC connectorized

### MOUNTING DIMENSIONS (for reference only) in./(mm)

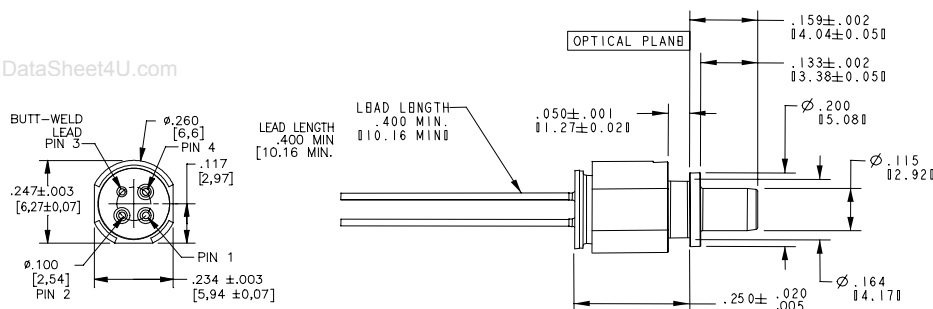

### PINOUT

Number	Function
1	V <sub>CC</sub>
2	Inverted Output
3	Ground
4	Non-Inverted Output

### WARRANTY/REMEDY

Honeywell warrants goods of its manufacture as being free of defective materials and faulty workmanship. Commencing with the date of shipment, Honeywell's warranty runs for 18 months. If warranted goods are returned to Honeywell during that period of coverage, Honeywell will repair or replace without charge those items it finds defective. The foregoing is Buyer's sole remedy and is **in lieu of all other warranties, expressed or implied, including those of merchantability and fitness for a particular purpose.**

While we provide application assistance, personally and through our literature, it is up to the customer to determine the suitability of the product in the application.

Specifications may change at any time without notice. The information we supply is believed to be accurate and reliable as of this printing. However, we assume no responsibility for its use.

### SALES AND SERVICE

MICRO SWITCH Sensing and Control serves its customers through a worldwide network of sales offices and distributors. For application assistance, current specifications, pricing or name of the nearest Authorized Distributor, contact a nearby sales office or call:

### TELEPHONE

1-800-367-6786 (USA)  
1-800-737-3360 (Canada)  
+49 (0) 89 35813310 (Germany)  
+65-580-3312 (Singapore)  
+44 (0) 118 981 9511 (UK)

### FAX

1-972-470-4326 (Customer Response Center)  
1-972-470-4549 (Fax on demand)  
+49 (0) 89 3599971 (Germany)  
+65 445 3033 (Singapore)  
+44 (0) 118 981 7513 (UK)

### INTERNET

<http://www.honeywell.com/VCSEL>  
[vcsel@honeywell.com](mailto:vcsel@honeywell.com)

Preliminary

05/10/02

**Honeywell**

**VCSEL Products**  
Honeywell Inc.  
11 West Spring Street  
Freeport, Illinois 61032



**VCSEL Products**  
Honeywell Inc.  
Optoelectronics Facility  
830 East Arapaho Road  
Richardson, Texas 75081

**Honeywell Control Systems Ltd.**  
Zodiac House  
Calleva Park  
Aldermaston, Berkshire  
RG7 8HW England

*Helping You Control Your World*

Printed with Soy Ink  
on 50% Recycled Paper

006697-1-EN IL50 GLO 797 Printed in USA

[www.DataSheet4U.com](http://www.DataSheet4U.com)

## Fiber Optic LAN Components Connectorized PIN Plus Preamplifier

### *HFD3180-002*

#### FEATURES

- Prealigned LC SFF Connector sleeve
- Data rates > 1GHz
- PIN detector and preamplifier in a TO-46 hermetic package
- 5V or 3.3V operation
- GaAs PIN detector and BiCMOS preamplifier
- Differential Output for low noise
- 1.1GHz Typical Bandwidth



The HFD3180-002 is a high-performance 850nm GaAs detector and pre-amplifier packaged for high-speed data communications. The product is designed for ease of use by the module designer or manufacturer in IEEE 802.3z (1.25Gbps Ethernet), ANSI 10625 (1.062 Gbps Fibre Channel) and ATM XXX, (622Mbps) communications standards.

The HFD3180-002 converts optical power into an electrical signal that is used in fiber optic communications and other applications. As the light increases, the output voltage increases, limiting at input powers above  $-10\text{dBm}$ . The differential output is designed to be **AC** coupled into a data amplifier. The pre-aligned and lensed package with an industry standard LC SFF style connector sleeve, allows for "drop in" assembly to reduce manufacturing cost.

The Honeywell HFD3180-002 is designed to interface with 50/125 and 62.5/125mm multimode fiber.

# Fiber Optic LAN Components

## Connectorized PIN Plus Preamplifier

HFD3180-002

### ABSOLUTE MAXIMUM RATINGS

Parameter	Rating
Storage Temperature	-40 to +85°C
Case Operating Temperature	0 to +70°C
Lead Solder Temperature	260°C, 10 sec.
Power Supply Voltage	-0.5 to 6 V
Incident Optical Power	0 dBm average, +4 dBm peak

### NOTICE

Stresses greater than those listed under “Absolute Maximum Ratings” may cause permanent damage to the device. This is a stress rating only and functional operation of the device at these or any other conditions above those indicated in the operations section for extended periods of time may affect reliability.

### ELECTRO-OPTICAL CHARACTERISTICS (V<sub>cc</sub>=3.3V, 0°C<T<70°C unless otherwise specified)

Parameters	Test Condition	Symbol	Min.	Typ.	Max.	Units	Notes
<b>Electrical Characteristics</b>							
Supply Voltage	P <sub>in</sub> = 0μW, R <sub>load</sub> =50Ω	V <sub>cc</sub>	3.0		5.5	Volts	1
Supply Current	P <sub>in</sub> = 0μW, R <sub>load</sub> =50Ω	I <sub>cc</sub>		35	47	mA	1
Output Offset Voltage	P <sub>in</sub> = 0μW, R <sub>load</sub> =50Ω	V <sub>offset</sub>	-100		100	mV	9,10
Output Resistance	Single ended, freq = 0Hz	R <sub>o</sub>	40	50	62	Ω	
<b>Opto-Electronic Characteristics</b>							
Responsivity	P <sub>in</sub> < AGC <sub>th</sub> , R <sub>load</sub> =50Ω	R	2500	3500	5000	μV/μW	2,3,10
Differential Output Voltage	P <sub>in</sub> = 200μW, R <sub>load</sub> =50Ω, V <sub>offset</sub> = 0 mV	V <sub>out</sub>		170	400	mV	1
Upper 3dB Bandwidth		BW <sub>upper</sub>	850	1100	1500	MHz	4
RMS Output Referred Noise	P <sub>in</sub> =0μW, R <sub>load</sub> =50Ω 937.5 MHz BT Filter			1.67	2.25	mV	5
Sensitivity	BER=10 <sup>-12</sup> , SNR=7	S	-20	-24		dBm	
Power Supply Rejection Ratio	P <sub>in</sub> =0μW, R <sub>load</sub> =50Ω	PSRR	10	30		dB	6
Pulse Width Distortion	P <sub>in</sub> =20μW peak, R <sub>load</sub> =50Ω	PWD			40	ps	7
Rise/Fall Time	P <sub>in</sub> =20μW peak, R <sub>load</sub> =50Ω	T <sub>R</sub> /T <sub>F</sub>			370	ps	8
Spectral Responsivity	P <sub>in</sub> =20μW peak, R <sub>load</sub> =50Ω	λ	760	850	860	nm	
AGC <sub>th</sub> threshold power	V <sub>offset</sub> = 0mV, P <sub>in</sub> = Peak power	AGC <sub>th</sub>		60		μW	9,10

### Notes:

- Pin refers to the peak optical power at the face of the fiber optic cable input to the HFD3180-102.
- Responsivity measured with source wavelength of 850nm, freq = 0Hz, P<sub>in</sub>< AGC<sub>th</sub>, R<sub>load</sub>=50Ω, sample tested at 2.5Gbps
- The output voltage increases as received light power increases, up to approximately -15dBm depending upon the AGC<sub>th</sub>. The preamplifier is designed to limit the electrical output signal above this optical input level, and does not introduce signal distortion until the average input power exceeds 0dBm.
- Bandwidth is measured with a small signal sinusoidal light source with 50 μW average power, R<sub>load</sub>=50Ω.
- RMS input referred optical noise is sample tested by measuring the RMS output referred noise, then dividing by the responsivity.
- PSRR is sample tested from 300KHz to 1GHz by injecting a -20dB electrical signal on the V<sub>cc</sub> pin. The nominal value at 100MHz is recorded. No external bypass components are assumed. An external V<sub>cc</sub> filter network will greatly increase the PSRR.
- Sample tested at the 50% level of output pulses.
- Rise and fall times are sample tested with source wavelength of 850nm, 125MHz square wave, with optical rise and fall times < 200ps, P<sub>in</sub>< AGC<sub>th</sub>, R<sub>load</sub>=50Ω. Measured at 20% - 80% signal levels
- Output offset voltage is defined as V<sub>out</sub> - V<sub>outQ</sub> with no light
- The AGC<sub>th</sub> power depends on the offset voltage. Refer to fig 3.

### NOTICE

The inherent design of this component causes it to be sensitive to electrostatic discharge (ESD). To prevent ESD-induced damage and/or degradation to equipment, take normal ESD precautions when handling this product

# Fiber Optic LAN Components

## Connectorized PIN Plus Preamplifier

HFD3180-002

FIGURE 1: INTERNAL SCHEMATIC DIAGRAM OF THE HFD3180-002

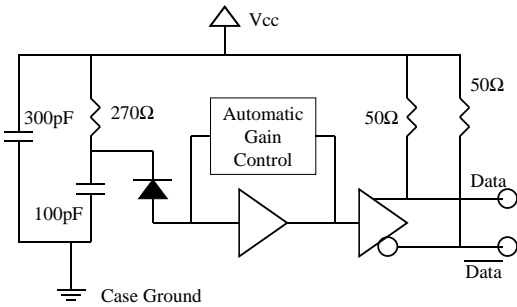

www.DataSheet4U.com

FIGURE 2: RECOMMENDED INTERFACE CIRCUIT FOR THE HFD3180-002

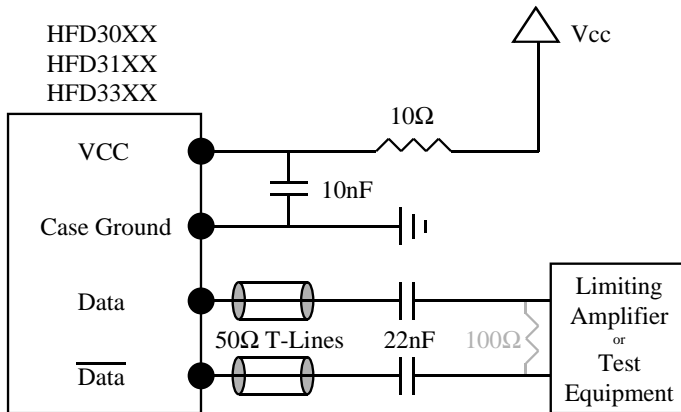

Note: 100Ω terminating resistor is optional

R=10 Ω

C<sub>1</sub> = 10 nF

C<sub>2</sub> = Data rate dependant (22nF for rates > 1Gbps)

FIGURE 3: AGC THRESHOLD POWER VS. OUTPUT OFFSET VOLTAGE

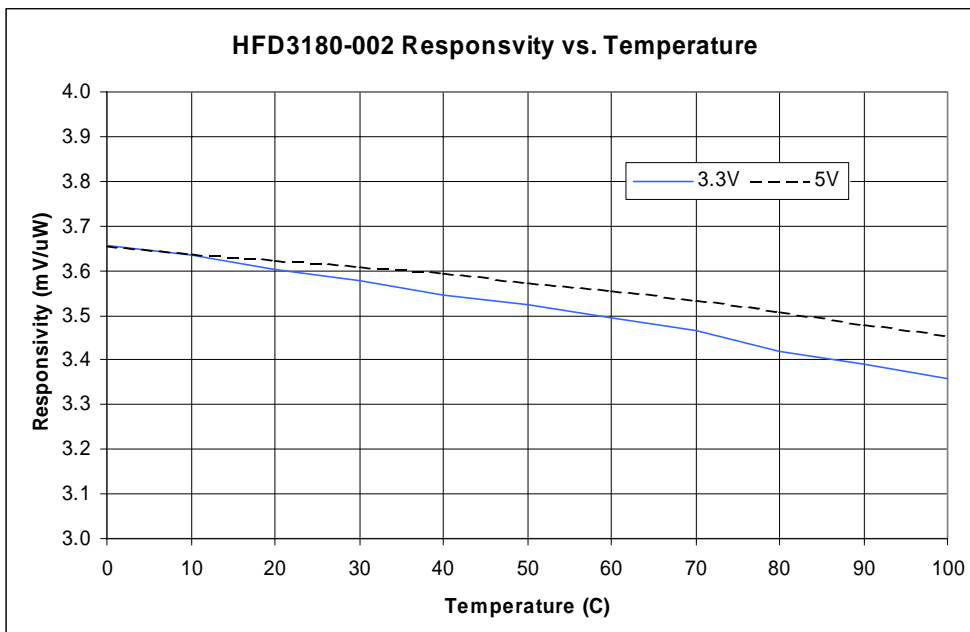

www.DataSheet4U.com

For application help: call 1-800-537-6945

Honeywell • 3

Courtesy of Steven Engineering, Inc. • 230 Ryan Way, South San Francisco, CA 94080-6370 • Main Office: (650) 588-9200 • Outside Local Area: (800) 258-9200 • www.stevenengineering.com

# Fiber Optic LAN Components

## Connectorized PIN Plus Preamplifier

# HFD3180-002

### ORDER GUIDE

Catalog Listing	Description
HFD3180-002	Connectorized PIN Plus Preamplifier

### MOUNTING DIMENSIONS (for reference only) in./.(mm)

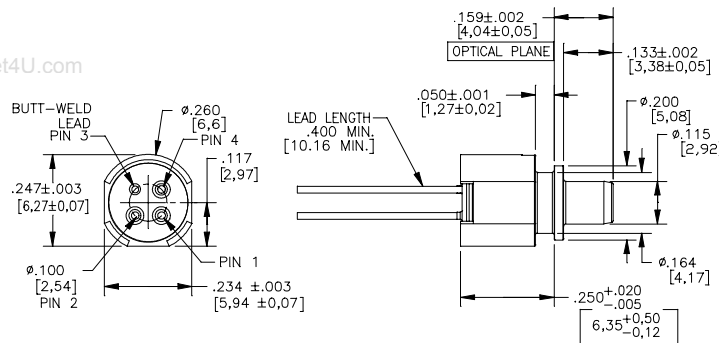

### PINOUT

Number	Function
1	V <sub>CC</sub>
2	Inverted Output
3	Ground
4	Non Inverted Output

### WARRANTY/REMEDY

Honeywell warrants goods of its manufacture as being free of defective materials and faulty workmanship. Commencing with the date of shipment, Honeywell's warranty runs for 18 months. If warranted goods are returned to Honeywell during that period of coverage, Honeywell will repair or replace without charge those items it finds defective. The foregoing is Buyer's sole remedy and is **in lieu of all other warranties, expressed or implied, including those of merchantability and fitness for a particular purpose.**

While we provide application assistance, personally and through our literature, it is up to the customer to determine the suitability of the product in the application.

Specifications may change at any time without notice. The information we supply is believed to be accurate and reliable as of this printing. However, we assume no responsibility for its use.

### SALES AND SERVICE

MICRO SWITCH Sensing and Control serves its customers through a worldwide network of sales offices and distributors. For application assistance, current specifications, pricing or name of the nearest Authorized Distributor, contact a nearby sales office or call:

### TELEPHONE

1-800-367-6786 (USA)  
 1-800-737-3360 (Canada)  
 +49 (0) 89 35813310 (Germany)  
 +65-580-3312 (Singapore)  
 +44 (0) 118 981 9511 (UK)

### FAX

1-972-470-4326 (Customer Response Center)  
 1-972-470-4549 (Fax on demand)  
 +49 (0) 89 3599971 (Germany)  
 +65 445 3033 (Singapore)  
 +44 (0) 118 981 7513 (UK)

### INTERNET

<http://www.honeywell.com/VCSEL>  
[VCSEL@HONEYWELL.COM](mailto:VCSEL@HONEYWELL.COM)

02/01/02

# Honeywell

Honeywell Inc.  
 11 West Spring Street  
 Freeport, Illinois 61032



Honeywell Inc.  
 Optoelectronics Facility  
 830 East Arapaho Road  
 Richardson, Texas 75081

**Honeywell Control Systems Ltd.**  
 Zodiac House  
 Calleva Park  
 Aldermaston, Berkshire  
 RG7 8HW England

*Helping You Control Your World*

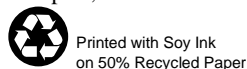

006697-1-EN IL50 GLO 797 Printed in USA

[www.DataSheet4U.com](http://www.DataSheet4U.com)

# Fiber Optic LAN Components

## Connectorized PIN Plus Preamplifier

HFD3180-002

Future Dimension (available starting late February 2002)

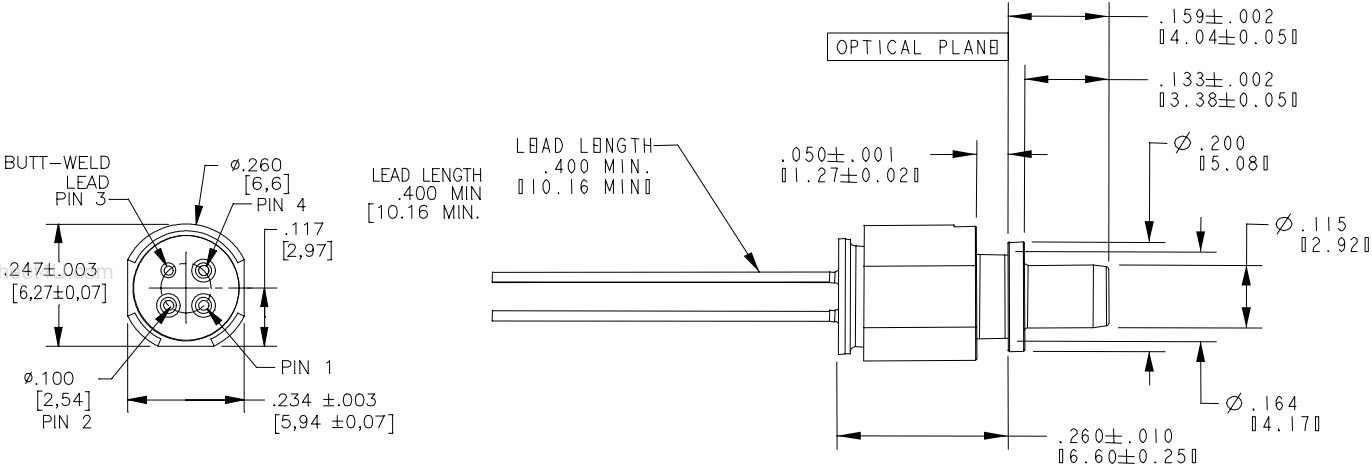

## Fiber Optic LAN Components Connectorized PIN Plus Preamplifier

### *HFD3381-002*

#### FEATURES

- Prealigned SC Connector sleeve
- Data rates > 1GHz
- PIN detector and preamplifier in a TO-46 hermetic package
- 5V or 3.3V operation
- GaAs PIN detector and BiCMOS preamplifier
- Differential Output for low noise
- 1.1GHz Typical Bandwidth



The HFD3381-002 is a high-performance 850nm GaAs detector and pre-amplifier packaged for high-speed data communications. The product is designed for ease of use by the module designer or manufacturer in IEEE 802.3z (1.25Gbps Ethernet), ANSI 10625 (1.062 Gbps Fibre Channel) and ATM XXX, (622Mbps) communications standards.

The HFD3381-002 converts optical power into an electrical signal that is used in fiber optic communications and other applications. As the light increases, the output voltage increases, limiting at input powers above  $-10\text{dBm}$ . The differential output is designed to be AC coupled into a data amplifier. The pre-aligned and lensed package with an industry standard SC style connector sleeve, allows for "drop in" assembly to reduce manufacturing cost.

The Honeywell HFD3381-002 is designed to interface with 50/125 and 62.5/125mm multimode fiber.

# Fiber Optic LAN Components

## Connectorized PIN Plus Preamplifier

HFD3381-002

### ABSOLUTE MAXIMUM RATINGS

Parameter	Rating
Storage Temperature	-40 to +85°C
Case Operating Temperature	0 to +70°C
Lead Solder Temperature	260°C, 10 sec.
Power Supply Voltage	-0.5 to 6 V
Incident Optical Power	0 dBm average, +4 dBm peak

### NOTICE

Stresses greater than those listed under “Absolute Maximum Ratings” may cause permanent damage to the device. This is a stress rating only and functional operation of the device at these or any other conditions above those indicated in the operations section for extended periods of time may affect reliability.

### ELECTRO-OPTICAL CHARACTERISTICS (V<sub>cc</sub>=3.3V, 0°C<T<70°C unless otherwise specified)

Parameters	Test Condition	Symbol	Min.	Typ.	Max.	Units	Notes
<b>Electrical Characteristics</b>							
Supply Voltage	P <sub>in</sub> = 0μW, R <sub>load</sub> =50Ω	V <sub>cc</sub>	3.0		5.5	Volts	1
Supply Current	P <sub>in</sub> = 0μW, R <sub>load</sub> =50Ω	I <sub>cc</sub>		35	47	mA	1
Output Offset Voltage	P <sub>in</sub> = 0μW, R <sub>load</sub> =50Ω	V <sub>offset</sub>	-100		100	mV	9,10
Output Resistance	Single ended, freq = 0Hz	R <sub>o</sub>	40	50	62	Ω	
<b>Opto-Electronic Characteristics</b>							
Responsivity	P <sub>in</sub> < AGC <sub>th</sub> , R <sub>load</sub> =50Ω	R	2500	3500	5000	μV/μW	2,3,10
Differential Output Voltage	P <sub>in</sub> = 200μW, R <sub>load</sub> =50Ω, V <sub>offset</sub> = 0 mV	V <sub>out</sub>		170	400	mV	1
Upper 3dB Bandwidth		BW <sub>upper</sub>	850	1100	1500	MHz	4
RMS Output Referred Noise	P <sub>in</sub> =0μW, R <sub>load</sub> =50Ω 937.5 MHz BT Filter			1.67	2.25	mV	5
Sensitivity	BER=10 <sup>-12</sup> , SNR=7	S	-20	-24		dBm	
Power Supply Rejection Ratio	P <sub>in</sub> =0μW, R <sub>load</sub> =50Ω	PSRR	10	30		dB	6
Pulse Width Distortion	P <sub>in</sub> =20μW peak, R <sub>load</sub> =50Ω	PWD			40	ps	7
Rise/Fall Time	P <sub>in</sub> =20μW peak, R <sub>load</sub> =50Ω	T <sub>R</sub> /T <sub>F</sub>			370	ps	8
Spectral Responsivity	P <sub>in</sub> =20μW peak, R <sub>load</sub> =50Ω	λ	760	850	860	nm	
AGC <sub>th</sub> threshold power	V <sub>offset</sub> = 0mV, P <sub>in</sub> = Peak power	AGC <sub>th</sub>		60		μW	9,10

### Notes:

- Pin refers to the peak optical power at the face of the fiber optic cable input to the HFD3180-102.
- Responsivity measured with source wavelength of 850nm, freq = 0Hz, P<sub>in</sub>< AGC<sub>th</sub>, R<sub>load</sub>=50Ω, sample tested at 2.5Gbps
- The output voltage increases as received light power increases, up to approximately -15dBm depending upon the AGC<sub>th</sub>. The preamplifier is designed to limit the electrical output signal above this optical input level, and does not introduce signal distortion until the average input power exceeds 0dBm.
- Bandwidth is measured with a small signal sinusoidal light source with 50 μW average power, R<sub>load</sub>=50Ω.
- RMS input referred optical noise is sample tested by measuring the RMS output referred noise, then dividing by the responsivity.
- PSRR is sample tested from 300KHz to 1GHz by injecting a -20dB electrical signal on the V<sub>cc</sub> pin. The nominal value at 100MHz is recorded. No external bypass components are assumed. An external V<sub>cc</sub> filter network will greatly increase the PSRR.
- Sample tested at the 50% level of output pulses.
- Rise and fall times are sample tested with source wavelength of 850nm, 125MHz square wave, with optical rise and fall times < 200ps, P<sub>in</sub>< AGC<sub>th</sub>, R<sub>load</sub>=50Ω. Measured at 20% - 80% signal levels
- Output offset voltage is defined as V<sub>out</sub> - V<sub>outQ</sub> with no light
- The AGC<sub>th</sub> power depends on the offset voltage. Refer to fig 3.

### NOTICE

The inherent design of this component causes it to be sensitive to electrostatic discharge (ESD). To prevent ESD-induced damage and/or degradation to equipment, take normal ESD precautions when handling this product



# Fiber Optic LAN Components

## Connectorized PIN Plus Preamplifier

HFD3381-002

FIGURE 1: INTERNAL SCHEMATIC DIAGRAM OF THE HFD3381-002

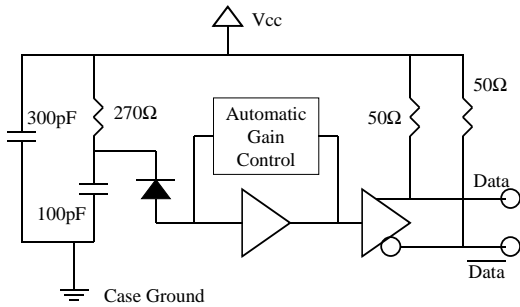

www.DataSheet4U.com

FIGURE 2: RECOMMENDED INTERFACE CIRCUIT FOR THE HFD3381-002

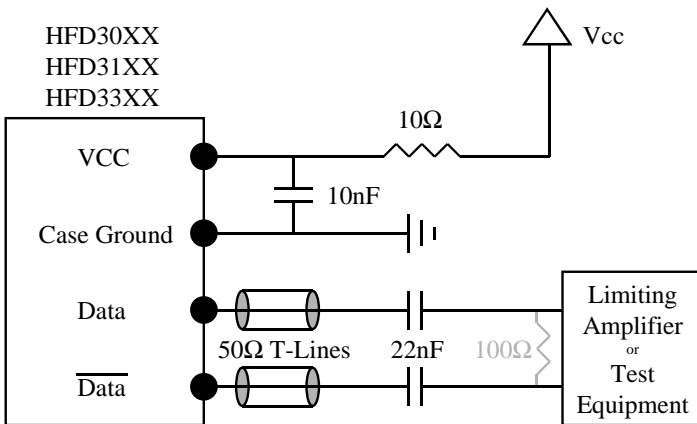

Note: 100Ω terminating resistor is optional

$R=10\ \Omega$

$C_1 = 10\ \text{nF}$

$C_2 = \text{Data rate dependant (22nF for rates > 1Gbps)}$

FIGURE 3: AGC THRESHOLD POWER VS. OUTPUT OFFSET VOLTAGE

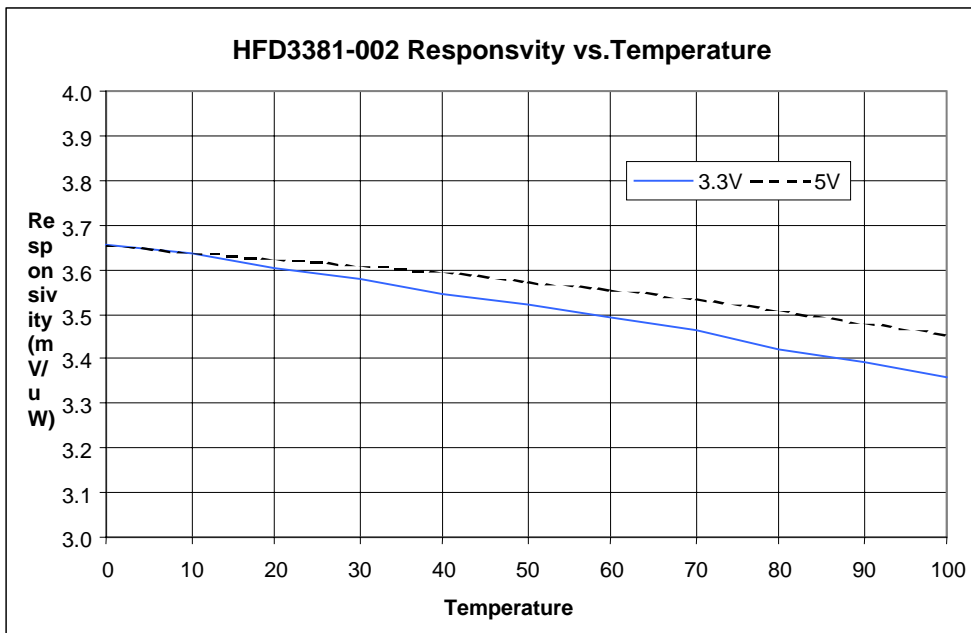

www.DataSheet4U.com

For application help: call 1-800-537-6945

Honeywell • 3

Courtesy of Steven Engineering, Inc. • 230 Ryan Way, South San Francisco, CA 94080-6370 • Main Office: (650) 588-9200 • Outside Local Area: (800) 258-9200 • www.stevenengineering.com

# Fiber Optic LAN Components

## Connectorized PIN Plus Preamplifier

# HFD3381-002

### ORDER GUIDE

Catalog Listing	Description
HFD3381-002	Connectorized PIN Plus Preamplifier

### MOUNTING DIMENSIONS (for reference only) in./(mm)

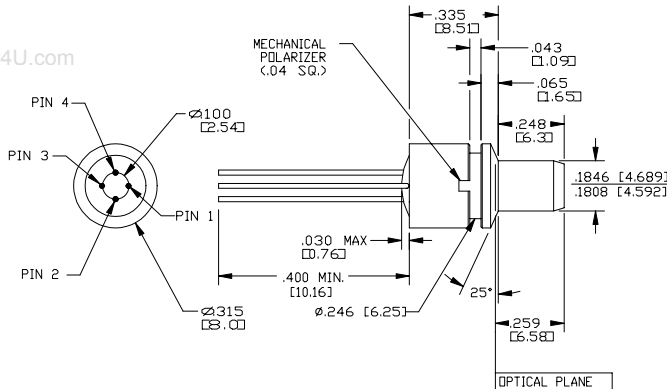

### PINOUT

Number	Function
1*	V <sub>CC</sub>
2	Inverted Output
3	Ground
4	Non Inverted Output

- \* Aligned with the Receptacle notch
- \* VCC is cut shorter.

### WARRANTY/REMEDY

Honeywell warrants goods of its manufacture as being free of defective materials and faulty workmanship. Commencing with the date of shipment, Honeywell's warranty runs for 18 months. If warranted goods are returned to Honeywell during that period of coverage, Honeywell will repair or replace without charge those items it finds defective. The foregoing is Buyer's sole remedy and is **in lieu of all other warranties, expressed or implied, including those of merchantability and fitness for a particular purpose.**

While we provide application assistance, personally and through our literature, it is up to the customer to determine the suitability of the product in the application.

Specifications may change at any time without notice. The information we supply is believed to be accurate and reliable as of this printing. However, we assume no responsibility for its use.

01/31/02

# Honeywell

Honeywell Inc.  
11 West Spring Street  
Freeport, Illinois 61032



Honeywell Inc.  
Optoelectronics Facility  
830 East Arapaho Road  
Richardson, Texas 75081

**Honeywell Control Systems Ltd.**  
Zodiac House  
Calleva Park  
Aldermaston, Berkshire  
RG7 8HW England

*Helping You Control Your World*

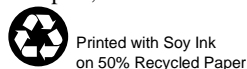

Printed with Soy Ink  
on 50% Recycled Paper

006697-1-EN IL50 GLO 797 Printed in USA

[www.DataSheet4U.com](http://www.DataSheet4U.com)