



**44Pin Flash Disk Module for 128MB,192M, 256M, True IDE Interface
Mode, 5.0V**

Part No. HFDOM44LX-xxxx

GENERAL DESCRIPTION

The HFDOM40LX series 44Pin Flash Disk on Module is a flash technology based with True IDE interface flash memory card for Lexar controller. It is constructed with flash disk controller chip and NAND-type (Samsung) flash memory device. The HFDOM44LX series operates in 5.0-Volt power supplies. It comes in capacity of 128, 192MB and up to 256 MB formatted 44Pin type .

By optimizing flash memory management, the life of this HFDOM44LX series can be extended to its maximum level. Because the ECC function is included, the correctness of data transfer between the HFDOM44LX series and a True IDE compatible interface device can be guaranteed.

The HFDOM44LX series is fully compatible with applications such as CPU card / board, set top box, industry / military PC, security equipment, measuring instrument and embedded systems.

FEATURES

- True IDE compatible host interface
- Direct plug in for 2.5" IDE Connectors
- 44 pin 2.00mm IDE Connector
- Ultra-High Performance
- Support for CIS implemented with 256 bytes of attribute memory
- 5.0V operation voltage
- Burst Rate (to/from Host): up to 16.6MB/s (PIO mode 4)
- Sustained Write (Host to flash): minimum of 1.2MB/s
- Data Transfer Rate (device to PC via USB interface): up to 850KB/s
- Capacity : Min. 128MB ~ Max. 256MB
- Auto Sleep Mode
- Low Power Dissipation
- Low VCC Program Inhibit Function

PRODUCT SPECIFICATIONS

Capacities :

128, 192 and up to 256 MB (formatted)

Operating Voltage : 5.0V \pm 10%

Power consumptions :

Read mode 65 mA (typ)

Write mode 65 mA (typ)

Sleep mode 300 uA (typ)

Environment conditions :

Operating temperature 0°C to + 70°C

Storage temperature - 25°C to + 85°C

Relative humidity 95%(Max)

Mechanical conditions :

Weight : Maximum 10.1g

ELECTRICAL SPECIFICATIONS

Table 1.1 Absolute Maximum Ratings

Parameters	Symbol	Min	Max	Unit	Test Condition
Storage Temperature	Tstg	-65	150	°C	
Power Supply Voltage	Vcc	-0.3	7	V	
Input or Output Voltage	Vin, Vout	GND-0.5	Vcc+0.5	V	

NOTE :Stress above those listed under Absolute Maximum Ratings may cause permanent damage to the device. This is a stress rating only and functional operation of the device at these or any conditions above those indicated in the operational sections of this specification is not implied. Exposure to absolute maximum rating conditions for extended periods may affect device reliability.

www.DataSheet4U.com

Table 1.2 Recommended Operating Conditions

Parameters	Symbol	Min	Max	Unit	Test Condition
Operating Temperature	Ta	0	70	°C	
Supply Voltage	Vcc	4.5	5.5	V	

Table 1.3 DC Characteristics (Ta = 0 to +70°C, Vcc = 5V ± 10%, Vcc = 3V ± 5%)

Parameters	Symbol	Min	Max	Unit	Test Condition
Power Supply voltage	Vdd	3.15	5.5	V	
Input Low Voltage	Vil	-0.5	0.8	V	
Input High Voltage	Vih	2.0	Vdd+0.3	V	
Output Low Voltage	Vol	-	0.4	V	
Output High Voltage	Voh	2.4	-	V	
Input Leakage	Ii	-5	5	uA	
Output Capacitance	Cout	-	10	pF	
Read Current	Irc		55	mA	
Write Current	Iwr		55	mA	
Sleep Current	Isc		200	uA	

CAPACITY SPECIFICATIONS

Table 1.4 Capacity Specifications

Part Number	Capacity (Unformatted)	Sectors/Card	Cylinders	Heads	Sectors/Track
HFDOM-44LX128	128,188,416 bytes	250,368	978	8	32
HFDOM-44LX192	193,462,272 bytes	377,856	738	16	32
HFDOM-44LX256	257,949,696 bytes	503,808	984	16	32

PHYSICAL SPECIFICATIONS

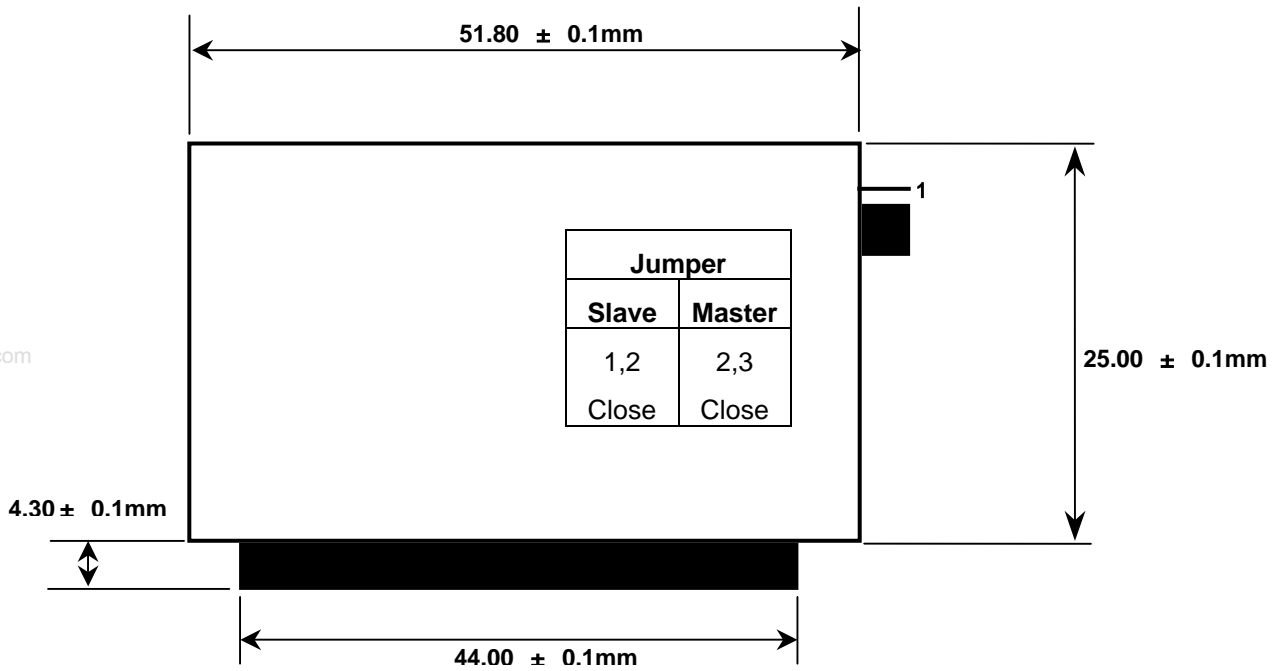

www.DataSheet4U.com

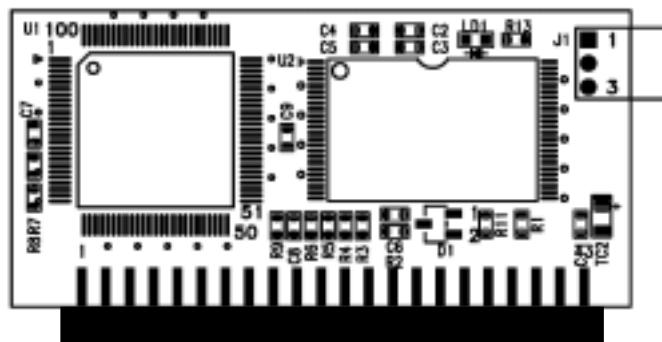
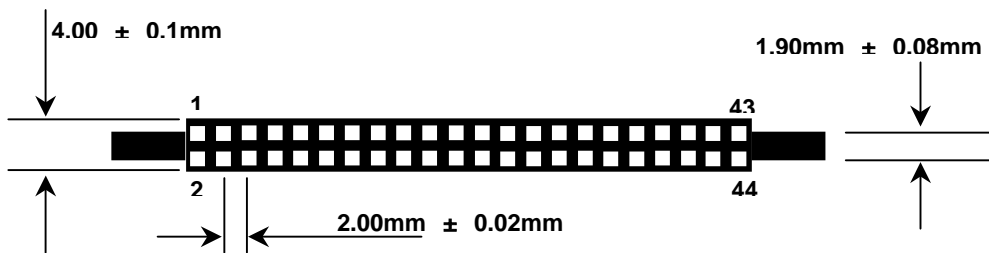

Figure 1.1 44 pin Type Flash Disk Module Dimensions

INSTALLTION GUIDE

1) Setting Method (for example)

Make sure your computer is turned off before you open the case.

Plug the carefully into the 44pin IDE slot on your computer.

Caution: Make sure to align pin1 on host adapter interface connector with pin 1 on your Flash Disk Module. Pin 1 is indicated by a triangle on the Flash Disk Module connector.

The Flash Disk Module is used power connector cable of the computer.

Caution: If you need to remove your Flash Disk Module, use both hands to pull it out carefully.

Check all cable connections and then replace your computer cover.

2) BIOS setting Method (for example)

Before you format or partition your new drive, you must configure your computer's BIOS so that the computer can recognize your new drive.

Turn your computer on. As your computer start up, watch the screen for a message describing how to run the system setup program on the screen (sometimes called BIOS or CMOS setup). This is usually done by pressing a special key, such as **Delete**, **Esc** or **F1** during startup. See your computer manual for details. Press the appropriate key to run the system setup program.

If your BIOS provides automatic drive detection (an "AUTO" drive type), select this option. (We recommend to use Normal / CHS mode to partition your Flash Disk Module to get the maximum formatted capacity.)

This allows your computer to configure itself automatically for your new drive.

If your BIOS dose not provide "AUTO" drive detection, select "User-defined" drive setting and enter the CHS values from the table. BIOS Settings (see specification) Capacity Cylinders Heads Sectors(unformatted)

Save the settings and exit the System Setup program. (your computer will automatically reboot) After you configure your computer, you can use the standard DOS commands to partition and format your Flash Disk Module, as described below.

3) Formatting Method (for example)

To partition your new Flash Disk Module with Microsoft DOS program :

Insert a bootable DOS diskette into your diskette drive and restart your computer.

Insert a DOS program diskette that contains the **FDISK.EXE** and **FORMAT.COM**

programs into your diskette drive. Use the same DOS version that is on your bootable diskette. At the **A:\ >** prompt, type "**FDISK**" and press **Enter**.

Select "**Create DOS partition or logical DOS drive**" by pressing **1**. Then press **Enter**.

Select "**Create primary DOS partition**" by pressing **1** again. Then press **Enter**.

Create your first drive partition. If you are creating a partition that will be used to boot your computer (drive C), make sure that the partition is marked active.

Create an extended partition and additional logical drives as necessary, until all the space on your new hard drive has been partitioned.

When the partitioning is complete, **FDISK** reboots your computer.

Caution: Make sure to use the correct drive letters so that you do not format a drive that already contains data.

At the **A:\ >** prompt, type "**format D:/s**", where **D** is **HFDOM44LX**, Repeat the format process for all the new partitions you have created.

After you format your drive, it is ready to use.

1. PIN INFORMATION

PIN ASSIGNMENTS AND PIN TYPE

Table 2.1 Pin Assignment and Pin type

Pin	Signal	Pin Type	Pin	Signal	Pin Type
1	/RESET	I	2	GND3	GND3
3	D07	I/O	4	D08	I/O
5	D06	I/O	6	D09	I/O
7	D05	I/O	8	D10	I/O
9	D04	I/O	10	D11	I/O
11	D03	I/O	12	D12	I/O
13	D02	I/O	14	D13	I/O
15	D01	I/O	16	D14	I/O
17	D00	I/O	18	D15	I/O
19	GND1	GND1	20	NC	KEY(no pin)
21	DREQ	DREQ	22	GND4	GND4
23	/OW	/OW	24	GND5	GND5
25	/OR	/OR	26	GND6	GND6
27	IOCHRDY	IORDY	28	H_SEL	CSEL
29	/DACK	/DACK	30	GND7	GND7
31	INT	IRQ	32	/IO16	/IOIS16
33	A01	I	34	/PDIAG	I/O
35	A00	I	36	A02	I
37	/CS0	/CS0	38	/CS1	I
39	/DASP (LED)	I/O	40	GND8	GND8
41	VCC1	VCC1	42	VCC2	VCC2
43	GND2	GND2	44	NC	RSVD2

Signal Descriptions

Table 2.2 Signal Descriptions

Signal Name	Dir.	Pin	Description
A[2:0]	I	33,35,36	In True IDE Mode only A[2:0] are used to select the one of eight registers in the Task File, the remaining address lines should be grounded by the host.
-PDIAG	I/O	34	This input / output is the Pass Diagnostic signal in the Master / Slave handshake protocol.
-DASP(LED)	I/O	39	This signal used either to drive an LED whenever the Disk Module is being accessed or as indication of a second drive present. This signal is active low when the Disk Module is busy.
-CS0, -CS1	I	37,38	CS0 is the chip select for the task file registers while CS2 is used to select the Alternate Status Register and the Device Control Register.
D[15:00]	I/O	3,4,5,6, 7,8,9,10, 11,12,13, 14,15,16, 17,18	All Task File operations occur in byte mode on the low order bus D00-D07 while all data transfers are 16 bit using D00-D15.
GND[8:1]	--	2,19,22, 24,26, 30,40, 43	Ground.
-IOR	I	25	This is an I/O Read strobe generated by the host.
-IOW	I	23	The I/O Write strobe pulse is used to clock I/O data on the Card Data bus into the Storage Card controller registers when the Storage Card is configured to use the I/O interface. The clocking will occur on the negative to positive edge of the signal (trailing edge).
IRQ	O	31	In True IDE Mode signal is the active high Interrupt Request to the host.
-RESET	I	1	This input pin is the active low hardware reset from the host.
IORDY	O	27	This output signal may be used as IORDY.
-IOCS16	O	32	This output signal is asserted low when this device is expecting a word data transfer cycle.
VCC[2:1]	I	41, 42	This input pin is used for VCC(5V).
NC (Not Connect)	--	20, 44	This pin is not used for signal on the module.

BLOCK DIAGRAM

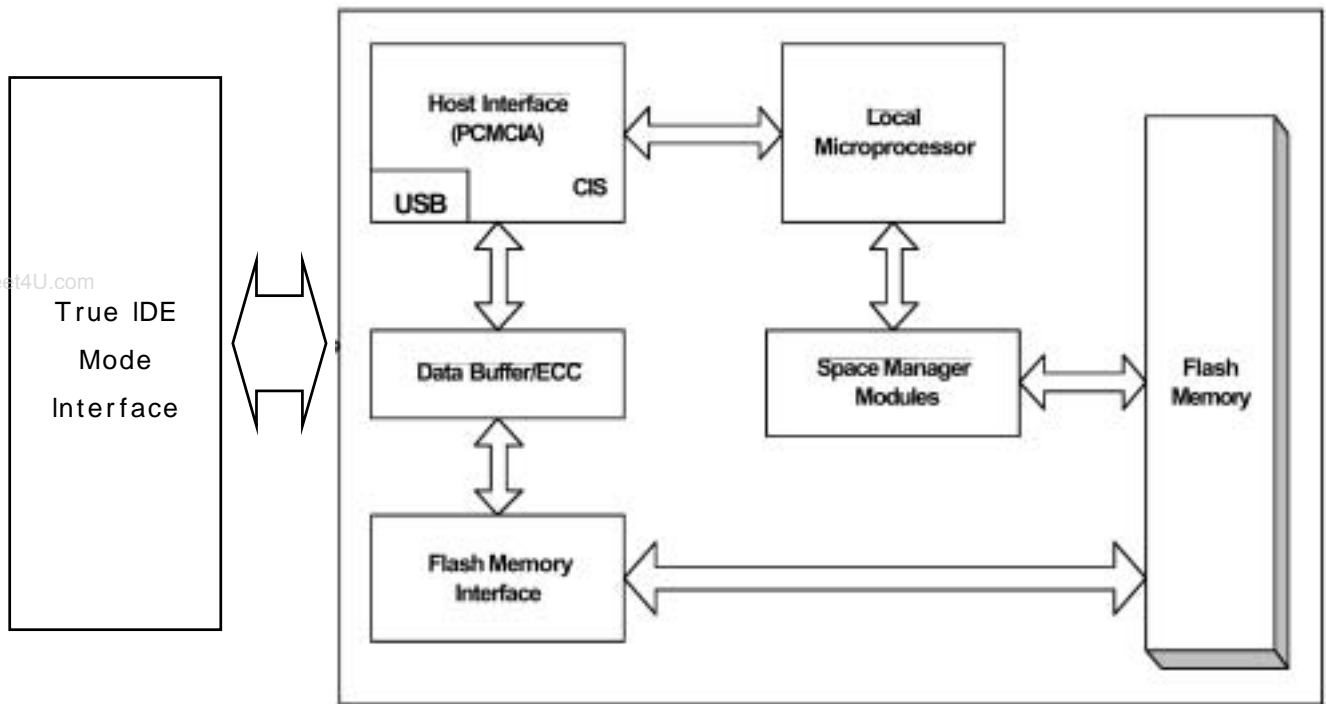

Figure 2.1 Flash Disk Module Block Diagram

2. INTERFACE BUS TIMING

ACCESS SPECIFICATIONS

IDE MODE I/O ACCESS SPECIFICATIONS

In this True IDE Mode the Flash Disk Module protocol and configuration are disabled and only I/O operations to the Task File and Data Register are allowed. In this mode no Memory or Attribute Registers are accessible to the host.

Table 3.1 IDE Mode I/O Read Access

Mode	-CE2	-CE1	A2-A0	-IOR	-IOWR	D15 - D8	D7 - D0
Invalid Mode	L	L	x	x	x	High-Z	High-Z
Standby Mode	H	H	x	x	x	High-Z	High-Z
Task File Read	H	L	1-7h	L	H	High-Z	Data Out
Data Register Read	L	H	L	L	H	Odd Byte out	Even Byte out

Table 3.2 IDE Mode I/O Read Timing

Parameter	Symbol	IEEE Symbol	Min. ns	Max. ns
Data Delay after IORD	td (IORD)	tIGLQV		100
Data Hold following IORD	th (IORD)	tIGHQX	0	
IORD Width Time	tw (IORD)	tIGLIGH	165	
Address Setup before IORD	tsuA (IORD)	tAVIGL	70	
Address Hold following IORD	thA (IORD)	tIGHAX	20	
CE Setup before IORD	tsuCE (IORD)	tELIGL	5	
CE Hold following IORD	thCE (IORD)	tIGHEH	20	
IOIS16 Delay Falling from Address	tdfIOIS16 (ADR)	tAVISL		35
IOIS16 Delay Rising from Address	tdrIOIS16 (ADR)	tAVISH		35

NOTE: The maximum load on -IOIS16 is 1 LSTTL with 50pF total load. All times are in nanoseconds. Minimum time from

-WAIT high to -IORD high is 0nsec, but minimum -IORD width must still be met.

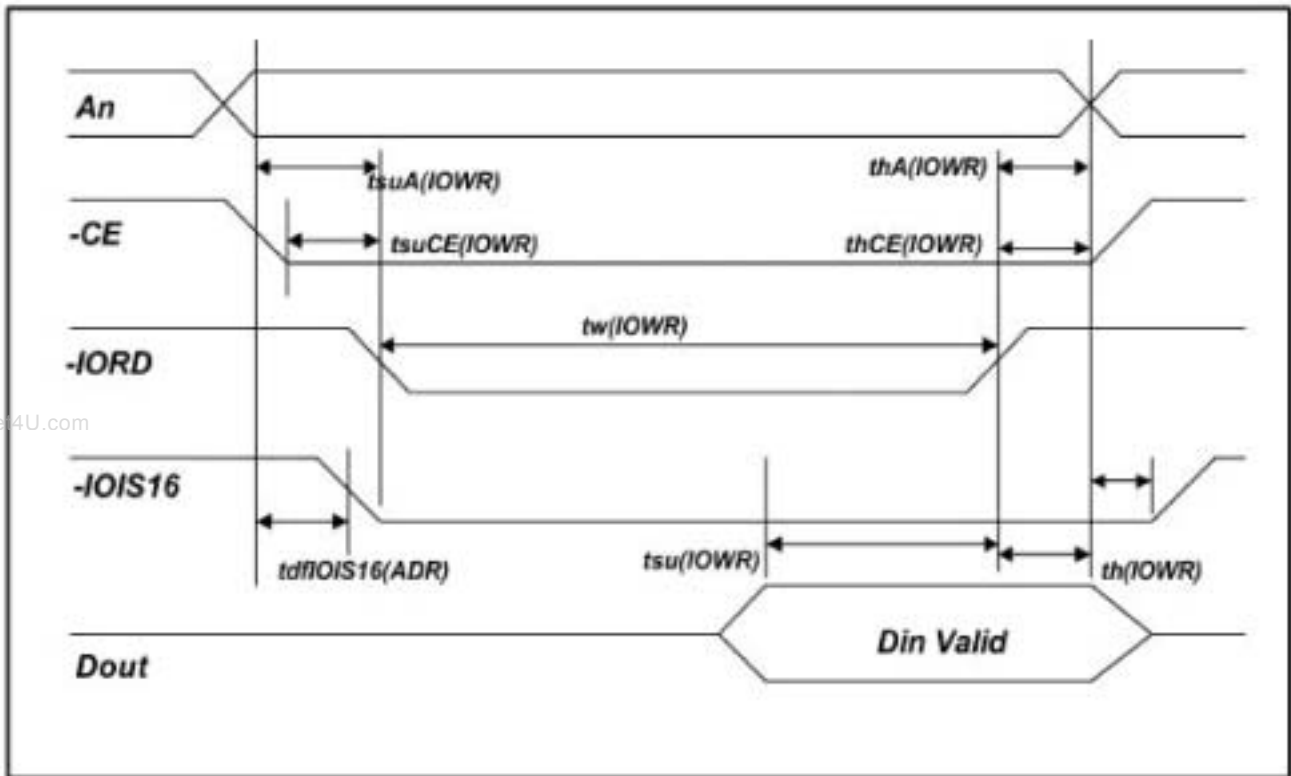

Figure 3.1 IDE Mode I/O Read Timing Example

Table 3.1 IDE Mode I/O Write Access

Mode	-CE2	-CE1	A2-A0	-IORD	-IOWR	D15 - D8	D7 - D0
Invalid Mode	L	L	x	x	x	High-Z	High-Z
Standby Mode	H	H	x	x	x	High-Z	High-Z
Task File Read	L	H	1-7h	H	L	x	Data In
Data Register Read	H	L	6h	H	L	x	Control In

Table 3.3 IDE Mode I/O Write Timing

Parameter	Symbol	IEEE Symbol	Min. ns	Max. ns
Data Setup before IOWR	tsu(IOWR)	tDVIWH	100	
Data Hold following IOWR	th(IOWR)	tIWHDX	0	
IOWR Width Time	tw(IOWR)	tIWLWH	165	
Address Setup before IOWR	tsuA(IOWR)	tAVIWL	70	
Address Hold following IOWR	thA(IOWR)	tIWHAX	20	
CE Setup before IOWR	tsuCE(IOWR)	tELIWL	5	
CE Hold following IOWR	thCE(IOWR)	tIWHHEH	20	
IOIS16 Delay Falling from Address	tdfIOIS16(ADR)	tAVISL		35
IOIS16 Delay Rising from Address	tdrIOIS16(ADR)	tAVISH		35

NOTE: The maximum load on -IOIS16 is 1 LSTTL with 50pF total load. All times are in nanoseconds. Minimum time from -WAIT high to -IOWR high is 0nsec, but minimum -IOWR width must still be met.

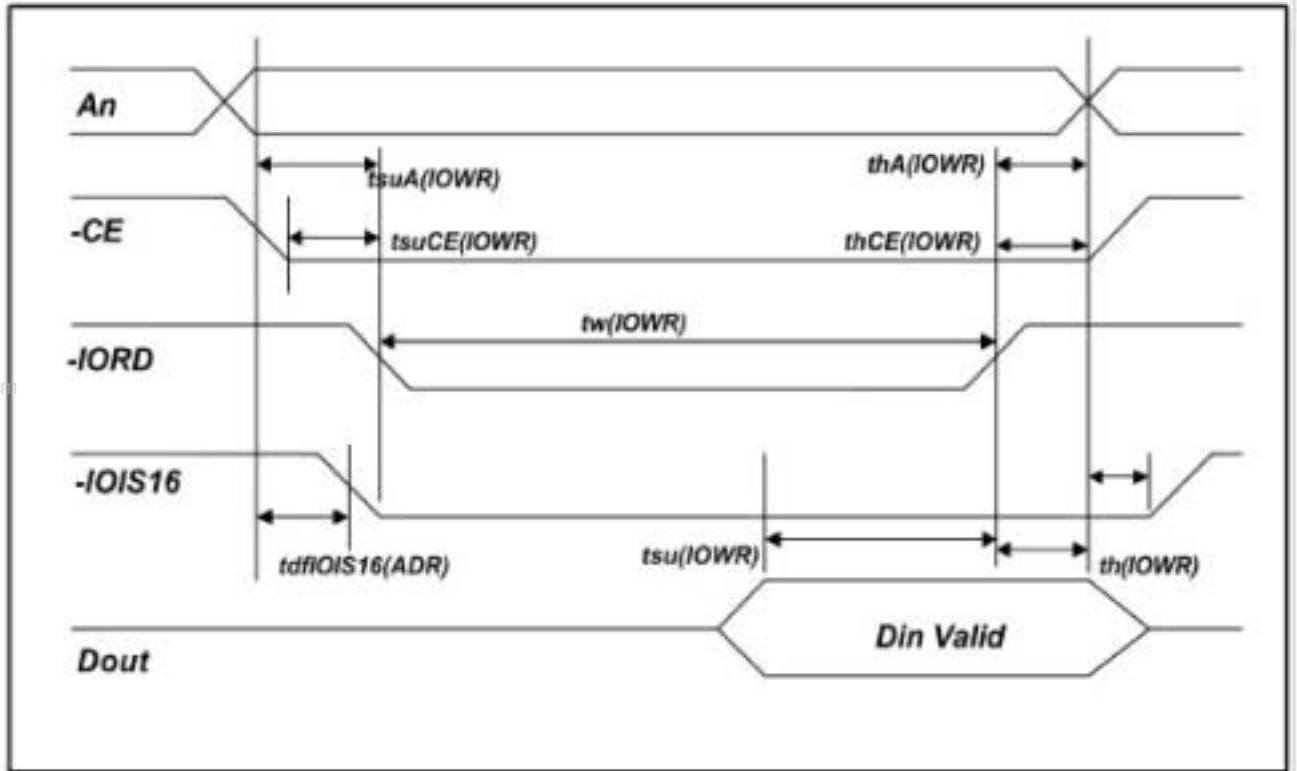

Figure 3.2 IDE Mode I/O Write Timing Example

Ordering Infomation

NO	Parts	Size	Capacity	Media transfer mode	Operation Mode
1	DO44LX128	51.80x25.0x1.9mm	128Mbyte	BYTE	True IDE
2	DO44LX192	51.80x25.0x1.9mm	192Mbyte	BYTE	True IDE
3	DO44LX256	51.80x25.0x1.9mm	256Mbyte	BYTE	True IDE