

# HFE21

# MINIATURE HIGH POWER LATCHING RELAY



### Features

- Latching relay
- 120A switching capability at Res.load
- According to the fault current and electrical life test of IEC 62055-31: UC1, UC2, UC3 (please see below table and notes2)
- 4kV dielectric strength(between coil and contacts)
- Environmental friendly product (RoHS compliant)
- Outline Dimensions: (52.0 x 43.0 x 22.0) mm

### CONTACT DATA

Contact arrangement	1A, 1B, 1U, 1V
Contact resistance	Typ.:0.35mΩ max. (at 100A) <sup>1)</sup>
Contact material	AgSnO <sub>2</sub>
Contact rating (Res. load)	100A 220VAC / 28VDC
Max. switching voltage	440VAC
Max. switching current	120A
Max. switching power	22000VA / 2800W
Mechanical endurance	1 x 10 <sup>6</sup> OPS

**Notes:** 1) Typical value: Sampling quantity for contact resistance shall not less than 20 pcs, take the average value from 5 continous measurements for each sample.

### CHARACTERISTICS

Insulation resistance	1000MΩ (at 500VDC)	
Dielectric strength	Between coil & contacts	4000VAC 1min
	Between open contacts	2000VAC 1min
Creepage distance	8mm	
Set time (at nomi. volt.)	20ms max.	
Reset time (at nomi. volt.)	20ms max.	
Shock resistance	Functional	98m/s <sup>2</sup>
	Destructive	980m/s <sup>2</sup>
Vibration resistance	10Hz to 55Hz 1.5mm DA	
Humidity	5% to 85% RH	
Ambient temperature	-40°C to 85°C	
Termination	QC	
Unit weight	Approx. 85g	
Construction	Dust protected	

**Notes:** The data shown above are initial values.

### COIL

Coil power	Single coil latching: Approx. 3.0W Double coils latching: Approx. 6.0W
------------	---

### COIL DATA

at 23°C

Nominal Voltage VDC	Set / Reset Voltage VDC max.	Pulse Duration ms min.	Coil Resistance x (1±10%) Ω	
6	4.8	75	Single coil latching	13
12	9.6	75		50
24	19.2	75		210
48	38.4	75		860
6	4.8	75	Double coils latching	6.5+6.5
12	9.6	75		25+25
24	19.2	75		105+105
48	38.4	75		430+430

### ELECTRICAL ENDURANCE

UC Class	Voltage (Uc)	Current (Ic)	Power Factor	Close Open time (s)	Electrical endurance (OPS)	
415 (UC1)	220VAC	80A	COSØ=1	10:20	3000	Total:6000
		10A	COSØ=0.4		3000	
416 (UC2)		80A	COSØ=1		5000	Total:10000
			COSØ=0.5		5000	
417 (UC3)		100A	COSØ=1		5000	Total:10000
			COSØ=0.5		5000	
NIL: (UC3)		100A	COSØ=1		5000	Total:10000
			COSØ=0.5		5000	

**Notes:** 1) Electrical endurance meet IEC62055-31 test requirement,do the inductive load test after the resistive load test.

2) Only some typical ratings of UC are listed above, if more special ratings required, please contact us.



HONGFA RELAY

ISO9001, ISO/TS16949, ISO14001, OHSAS18001, IECQ QC 080000 CERTIFIED

2016 Rev. 1.00

## ORDERING INFORMATION

Type	HFE21		-C	120	/12	-D	T	2	-R (XXX)
Version	<p>A: Type A contact terminal          B: Type B contact terminal          C: Type C contact terminal          D: Type D contact terminal          G: Type G contact terminal          I: Type I contact terminal          J: Type J contact terminal</p>								
shunt <sup>1)</sup>	120:120 $\mu\Omega$	Nil: Without shunt							
Coil voltage	6, 12, 24, 48VDC								
Contact form <sup>2)</sup>	<p>D: 1 Form B (Single-contact)          H: 1 Form A (Single-contact)          SD: 1 Form B (Double-contact of 1 Form B)          SH: 1 Form A (Double-contact of 1 Form A)</p>								
Contact material	T: AgSnO <sub>2</sub>								
Sort	1: Single coil latching		2: Double coils latching						
Polarity	R: Negative polarity		Nil: Positive polarity						
Special code <sup>3) 4)</sup>	XXX: Customer special requirement		Nil: Standard(See electrical endurance)						

Notes: 1) 120: 120 $\mu\Omega$  is just the reference value, further resistance upon request.

2) H, SH means that relay is on the "reset" status when delivery; D, SD means that relay is on the "set" status when delivery. If no special requirement by customer, we will keep the relay on the "set" status when delivery.

3) Please make clear your technical requirements, and choose from the following 3 UC ratings:

UC1: meet the UC1 requirements on IEC62055-31: Carrying test 2400A peak current for 10ms;

UC2: meet the UC2 requirements on IEC62055-31: Making test:2.5kA/10ms carrying test 4.5kA/10ms;

UC3: meet the UC3 requirements on IEC62055-31: Making test:3kA/10MS; carrying test 6kA/10ms.

4) The customer special requirement express as special code after evaluating by Hongfa. e.g. (415) stands for UC1; e.g. (416) stands for UC2; e.g. (417) stands for UC3.

## OUTLINE DIMENSIONS AND WIRING DIAGRAM

Unit: mm

### Outline Dimensions

Type C contact terminal

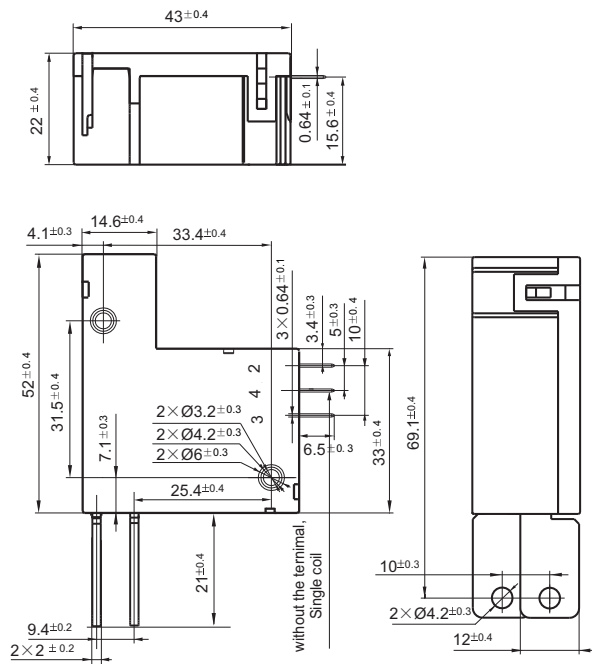

Typical shunt(120 $\mu\Omega$ )

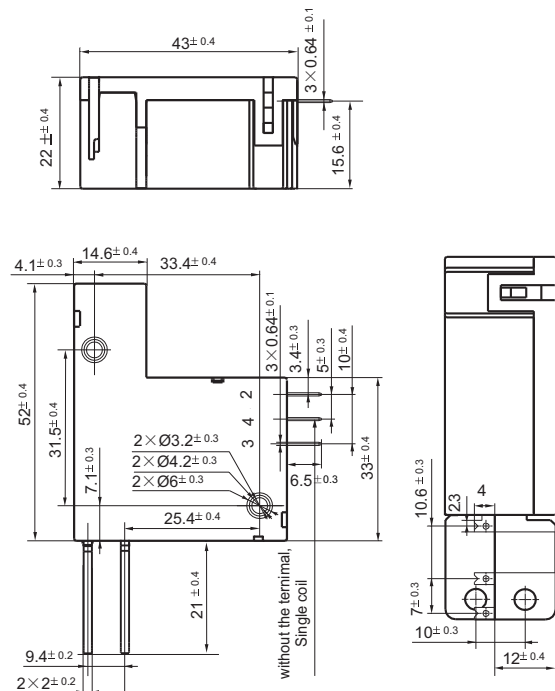

Outline Dimensions

Type A contact terminal

Type B contact terminal

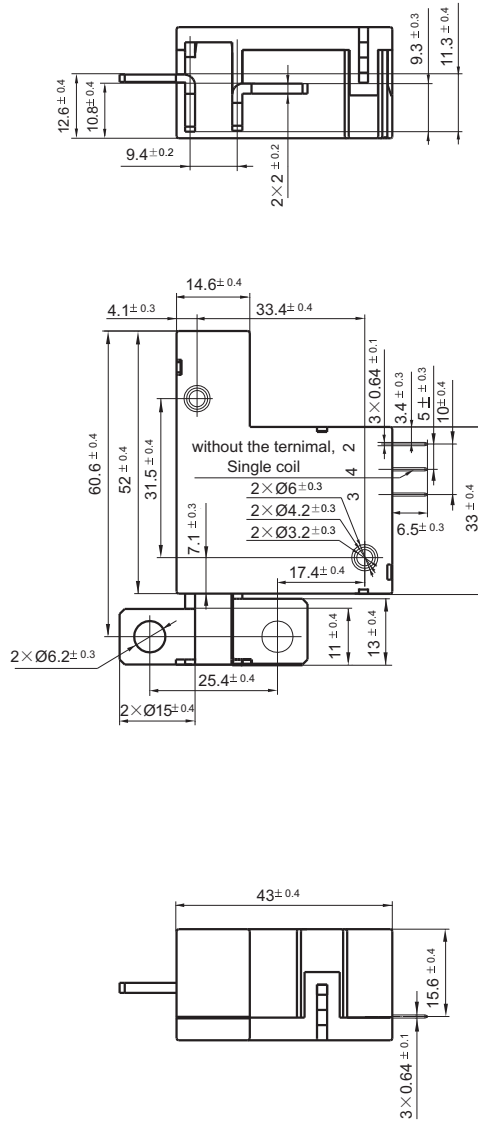
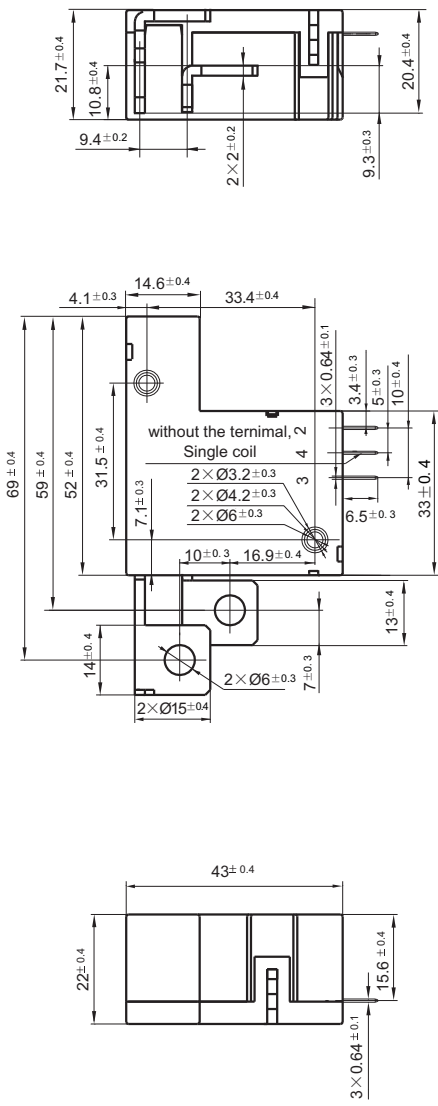

Outline Dimensions

Type D contact terminal

Type G contact terminal

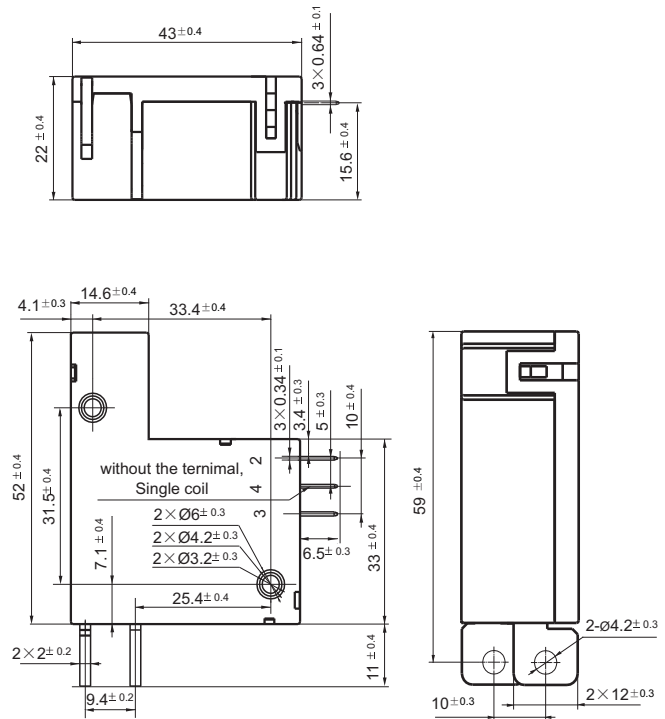
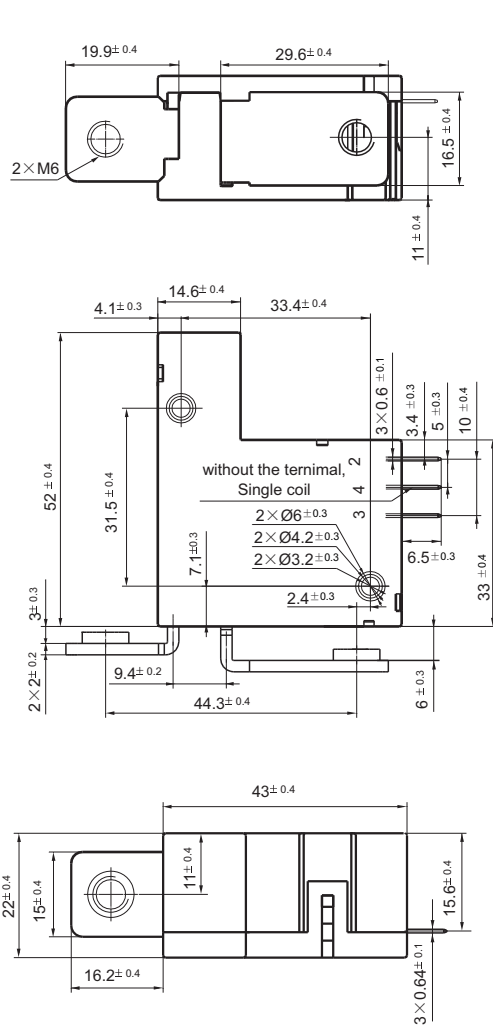



Outline Dimensions

Type J contact terminal

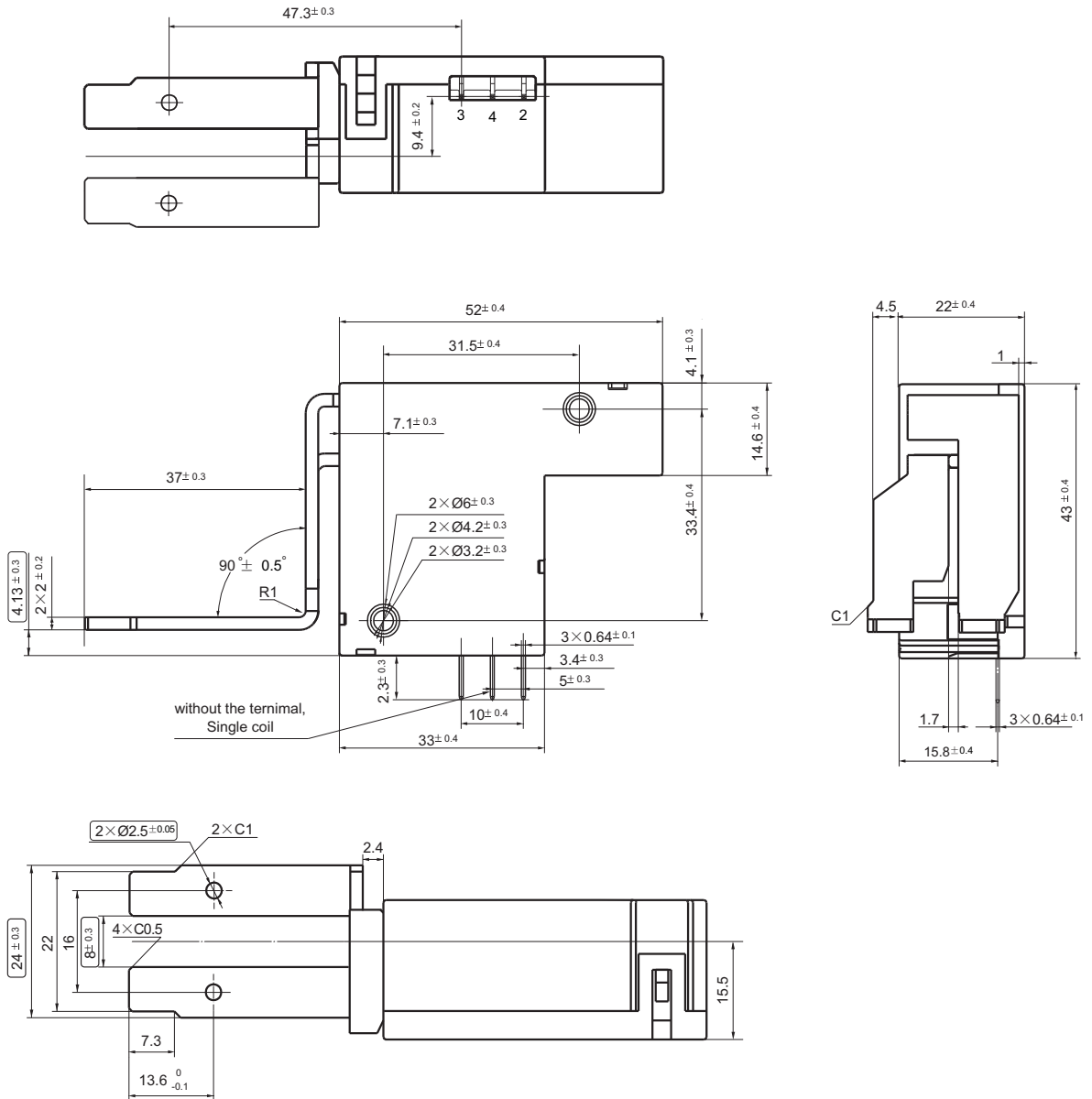

Remark: In case of no tolerance shown in outline dimension: outline dimension  $\leq 1$ mm, tolerance should be  $\pm 0.1$ mm; outline dimension  $> 1$ mm and  $\leq 5$ mm, tolerance should be  $\pm 0.2$ mm; outline dimension  $> 5$ mm, tolerance should be  $\pm 0.4$ mm.

Coil Wiring Diagram

Positive polarity

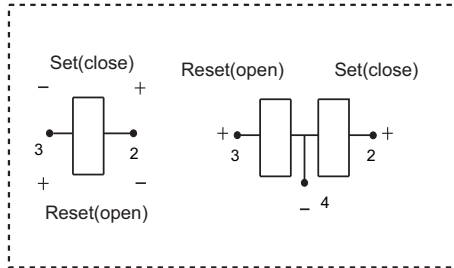

Negative polarity

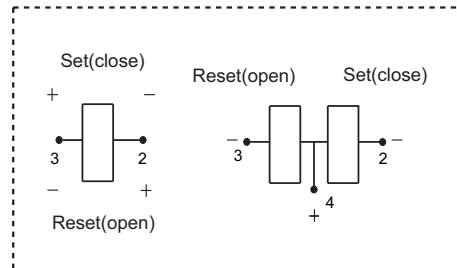

**Notice:**

1. Relay is on the "reset" or "set" status when being released from stock, with the consideration of shock risen from transit and relay mounting, relay would be changed to "set" or "reset" status, therefore, when application (connecting the power supply), please reset the relay to "set" or "reset" status on request.
2. In order to maintain "set" or "reset" status, energized voltage to coil should reach the rated voltage, impulse width should be 5 times more than "set" or "reset" time. Do not energize voltage to "set" coil and "reset" coil simultaneously. And also long energized time (more than 1 min) should be avoided.
3. The terminals of relay without twisted copper wire can not be tin-soldered, can not be moved willfully.
4. relays used for metering measuring applications are usually made with dust proof structure, while most relays could be made specially per customer's specific requirements.No longer than 6 months' storage time is recommended for this kind of relay, and please pay attention to the storage environment. To ensure contact reliability, we will keep contact status be closed when delivery if no special required by customer.

**Disclaimer**

The specification is for reference only. Specifications subject to change without notice.

We could not evaluate all the performance and all the parameters for every possible application. Thus the user should be in a right position to choose the suitable product for their own application. If there is any query, please contact Hongfa for the technical service. However, it is the user's responsibility to determine which product should be used only.

© Xiamen Hongfa Electroacoustic Co., Ltd. All rights of Hongfa are reserved.