

### 45V N-Ch Power MOSFET

#### Feature

- ◇ High Speed Power Switching
- ◇ Enhanced Body diode dv/dt capability
- ◇ Enhanced Avalanche Ruggedness
- ◇ 100% UIS Tested, 100% Rg Tested
- ◇ Lead Free

#### Application

- ◇ Synchronous Rectification in SMPS
- ◇ Hard Switching and High Speed Circuit
- ◇ Power Tools
- ◇ UPS
- ◇ Motor Control

$V_{DS}$		45	V
$R_{DS(on),typ}$	TO-263	1.55	mΩ
$R_{DS(on),typ}$	TO-247	1.75	mΩ
$R_{DS(on),typ}$	TO-220	1.75	mΩ
$I_D$ (Silicon Limited)		288	A
$I_D$ (Package Limited)		120	A

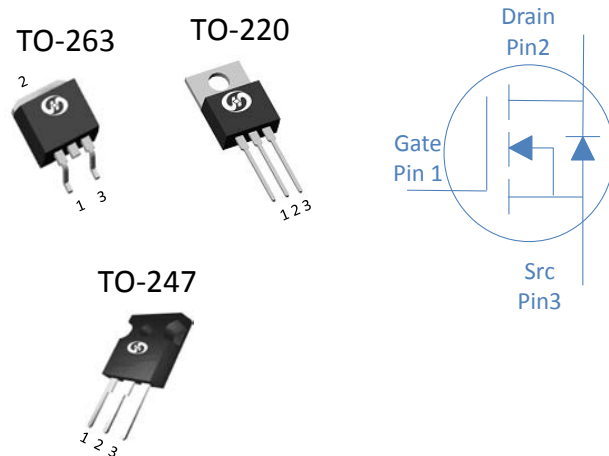

Part Number	Package	Marking
HGB020NE4S	TO-263	GB020NE4S
HGK020NE4S	TO-247	GK020NE4S
HGP020NE4S	TO-220	GP020NE4S

#### Absolute Maximum Ratings at $T_j=25^\circ\text{C}$ (unless otherwise specified)

Parameter	Symbol	Conditions	Value	Unit
Continuous Drain Current (Silicon Limited)	$I_D$	$T_C=25^\circ\text{C}$	288	A
		$T_C=100^\circ\text{C}$	204	
		Continuous Drain Current (Package Limited)	$T_C=25^\circ\text{C}$	
Drain to Source Voltage	$V_{DS}$	-	45	V
Gate to Source Voltage	$V_{GS}$	-	$\pm 20$	V
Pulsed Drain Current	$I_{DM}$	-	700	A
Avalanche Energy, Single Pulse	$E_{AS}$	$L=0.4\text{mH}, T_C=25^\circ\text{C}$	720	mJ
Power Dissipation	$P_D$	$T_C=25^\circ\text{C}$	300	W
Operating and Storage Temperature	$T_J, T_{stg}$	-	-55 to 175	$^\circ\text{C}$

#### Absolute Maximum Ratings

Parameter	Symbol	Max	Unit
Thermal Resistance Junction-Case	$R_{\theta JC}$	0.5	$^\circ\text{C/W}$
Thermal Resistance Junction-Ambient	$R_{\theta JA}$	60	$^\circ\text{C/W}$

**Electrical Characteristics at T<sub>j</sub>=25°C (unless otherwise specified)**
**Static Characteristics**

Parameter	Symbol	Conditions	Value			Unit	
			min	typ	max		
Drain to Source Breakdown Voltage	V <sub>(BR)DSS</sub>	V <sub>GS</sub> =0V, I <sub>D</sub> =250μA	45	-	-	V	
Gate Threshold Voltage	V <sub>GS(th)</sub>	V <sub>GS</sub> =V <sub>DS</sub> , I <sub>D</sub> =250μA	2	2.4	3		
Zero Gate Voltage Drain Current	I <sub>DSS</sub>	V <sub>GS</sub> =0V, V <sub>DS</sub> =45V, T <sub>j</sub> =25°C	-	-	1	μA	
		V <sub>GS</sub> =0V, V <sub>DS</sub> =45V, T <sub>j</sub> =100°C	-	-	100		
Gate to Source Leakage Current	I <sub>GSS</sub>	V <sub>GS</sub> =±20V, V <sub>DS</sub> =0V	-	-	±100	nA	
Drain to Source on Resistance	R <sub>DS(on)</sub>	V <sub>GS</sub> =10V, I <sub>D</sub> =20A	TO-263	-	1.55	1.7	mΩ
			TO-247	-	1.75	2.0	
			TO-220	-	1.75	2.0	
Transconductance	g <sub>fs</sub>	V <sub>DS</sub> =5V, I <sub>D</sub> =20A	-	90	-	S	
Gate Resistance	R <sub>G</sub>	V <sub>GS</sub> =0V, V <sub>DS</sub> Open, f=1MHz	-	0.7	-	Ω	

**Dynamic Characteristics**

Input Capacitance	C <sub>iss</sub>	V <sub>GS</sub> =0V, V <sub>DS</sub> =20V, f=1MHz	-	8070	-	pF
Output Capacitance	C <sub>oss</sub>		-	2210	-	
Reverse Transfer Capacitance	C <sub>rss</sub>		-	114	-	
Total Gate Charge	Q <sub>g</sub>	V <sub>DD</sub> =20V, I <sub>D</sub> =20A, V <sub>GS</sub> =10V	-	96	-	nC
Gate to Source Charge	Q <sub>gs</sub>		-	22	-	
Gate to Drain (Miller) Charge	Q <sub>gd</sub>		-	10	-	
Turn on Delay Time	t <sub>d(on)</sub>	V <sub>DD</sub> =20V, I <sub>D</sub> =20A, V <sub>GS</sub> =10V, R <sub>G</sub> =10Ω,	-	18	-	ns
Rise time	t <sub>r</sub>		-	13	-	
Turn off Delay Time	t <sub>d(off)</sub>		-	65	-	
Fall Time	t <sub>f</sub>		-	19	-	

**Reverse Diode Characteristics**

Diode Forward Voltage	V <sub>SD</sub>	V <sub>GS</sub> =0V, I <sub>F</sub> =20A	-	0.8	1.2	V
Reverse Recovery Time	t <sub>rr</sub>	V <sub>R</sub> =20V, I <sub>F</sub> =20A, dI <sub>F</sub> /dt=200A/μs	-	55	-	ns
Reverse Recovery Charge	Q <sub>rr</sub>		-	83	-	nC

Fig 1. Typical Output Characteristics

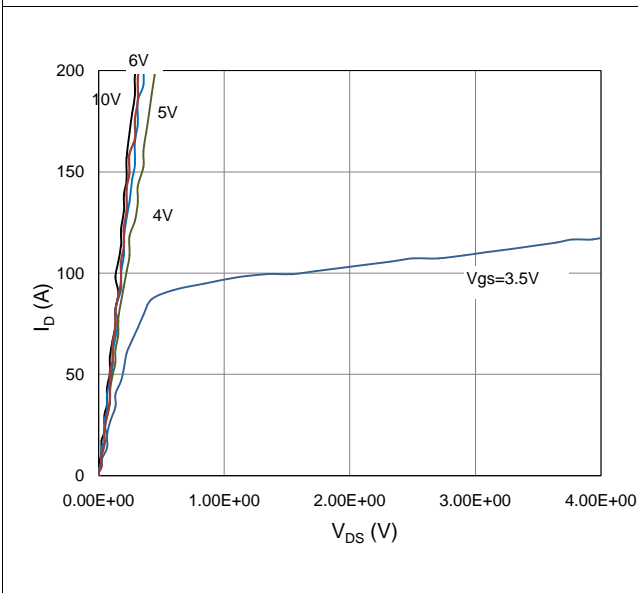

Figure 2. On-Resistance vs. Gate-Source Voltage

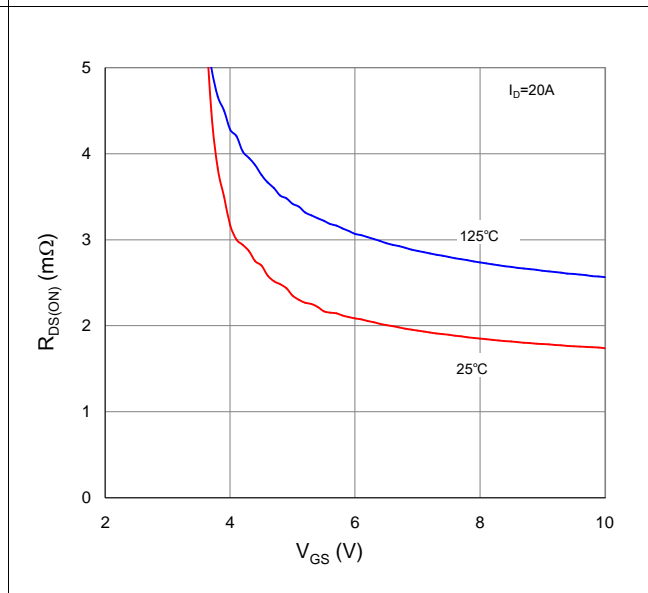

Figure 3. On-Resistance vs. Drain Current and Gate Voltage

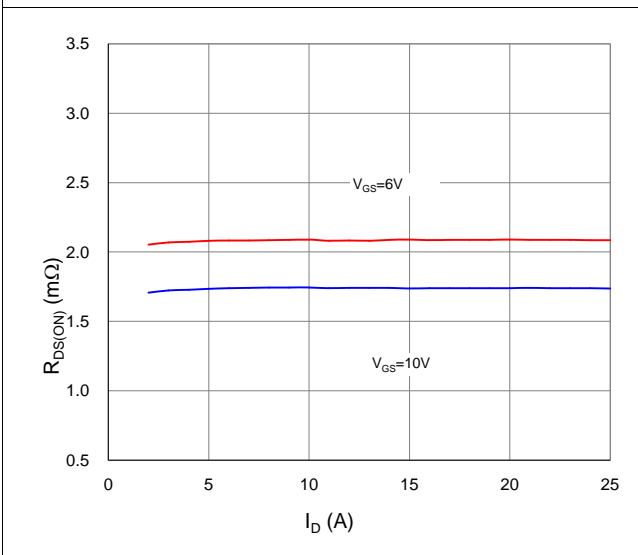

Figure 4. Normalized On-Resistance vs. Junction Temperature

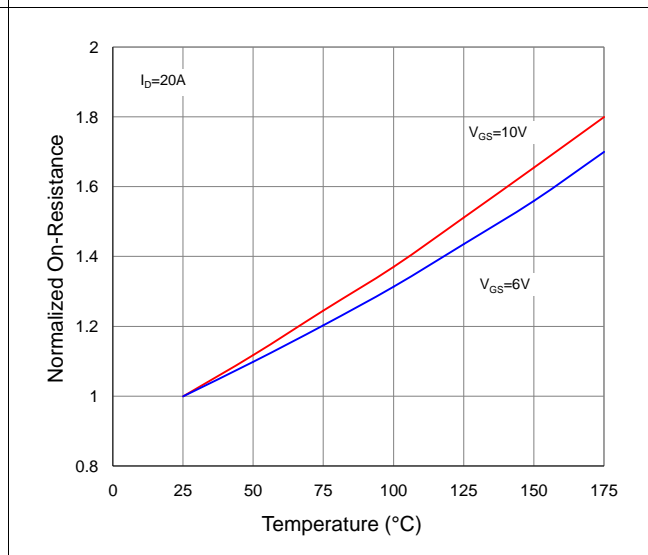

Figure 5. Typical Transfer Characteristics

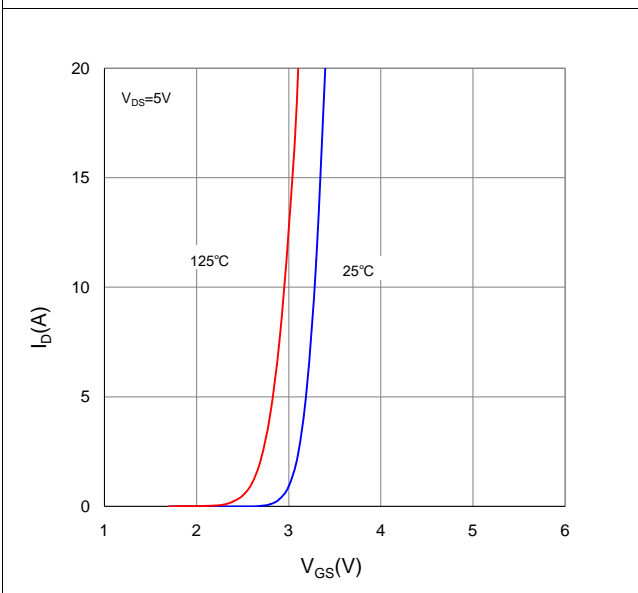

Figure 6. Typical Source-Drain Diode Forward Voltage

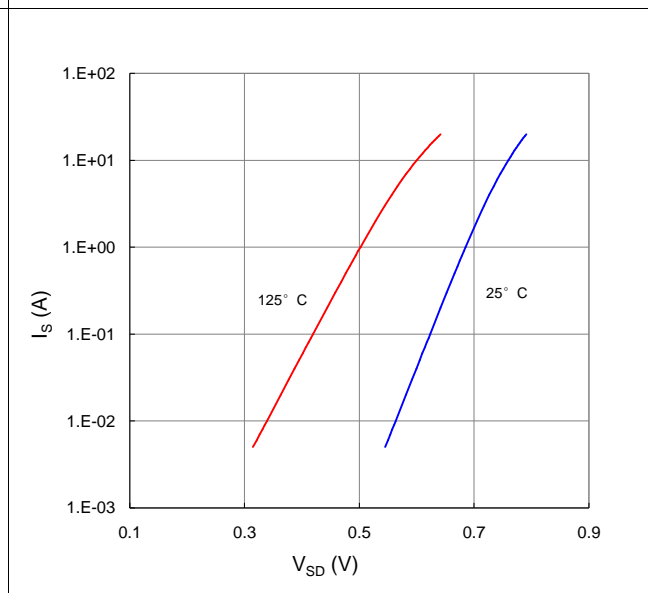

Figure 7. Typical Gate-Charge vs. Gate-to-Source Voltage

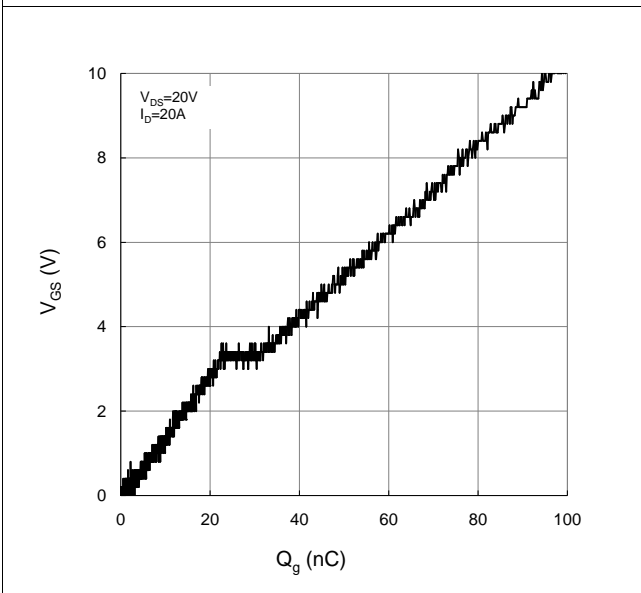

Figure 8. Typical Capacitance vs. Drain-to-Source Voltage

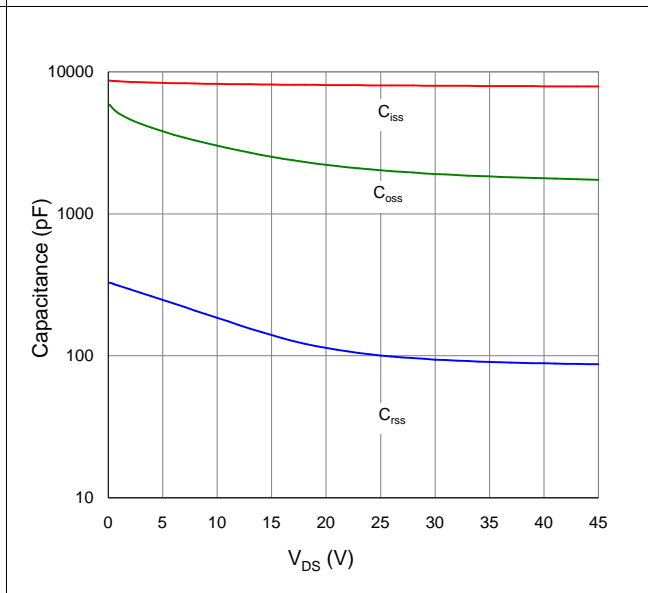

Figure 9. Maximum Safe Operating Area

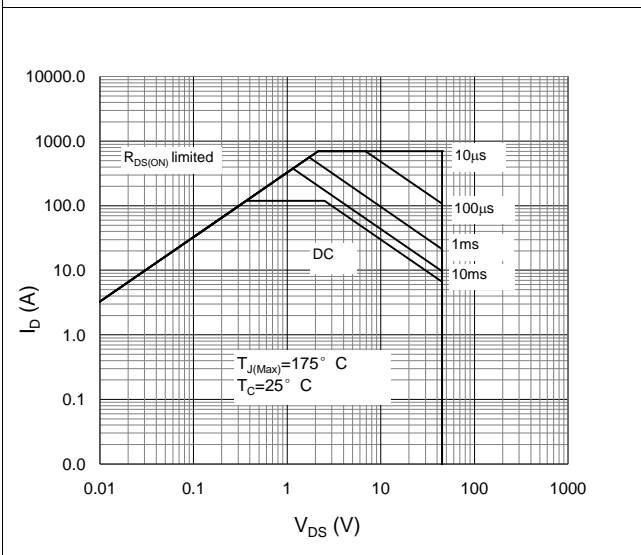

Figure 10. Maximum Drain Current vs. Case Temperature

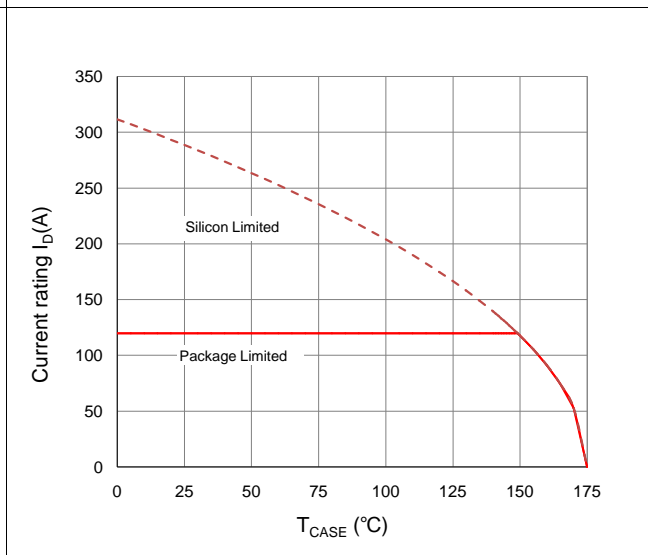
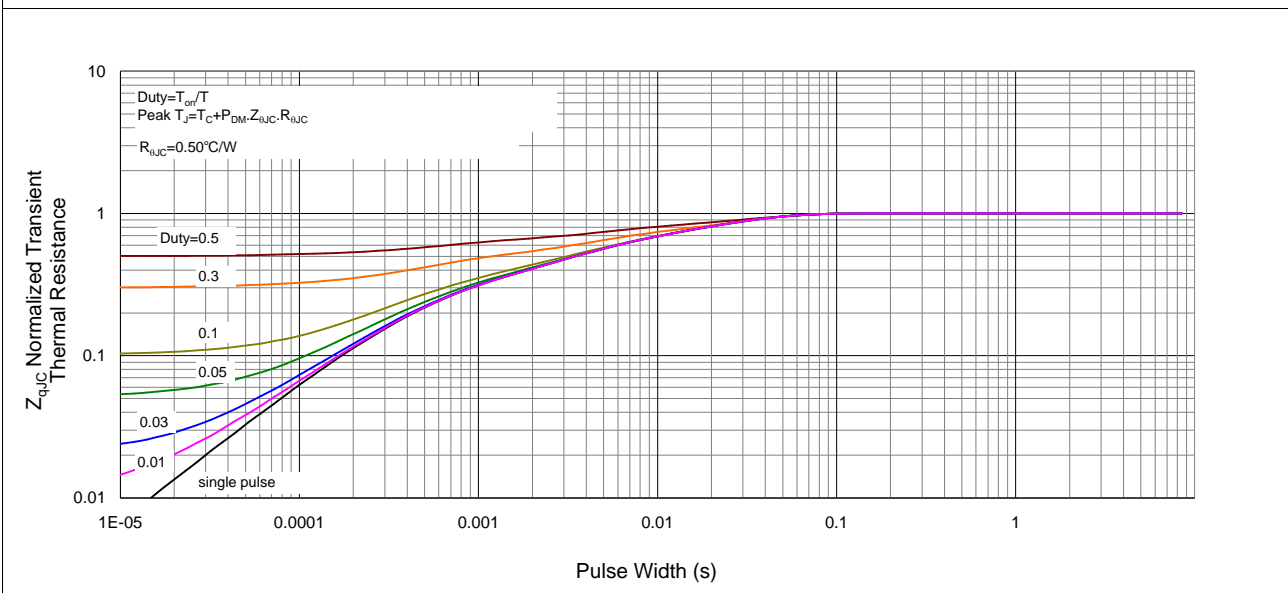
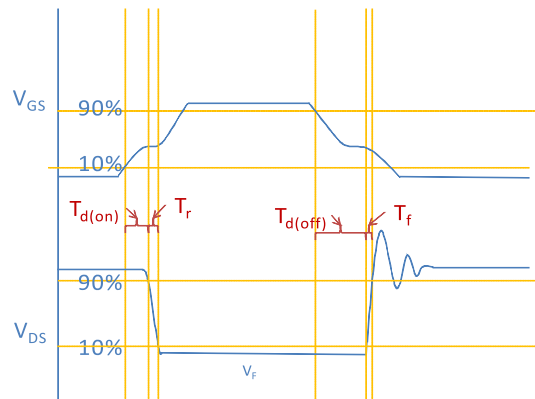
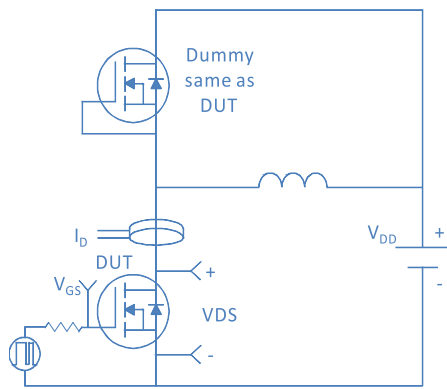

Figure 11. Normalized Maximum Transient Thermal Impedance, Junction-to-Case



### Inductive switching Test



### Gate Charge Test

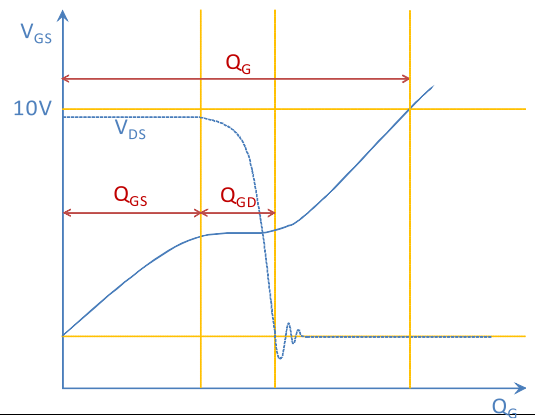
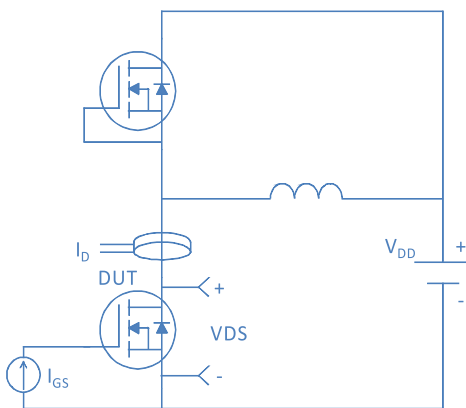

### Uclamped Inductive Switching (UIS) Test

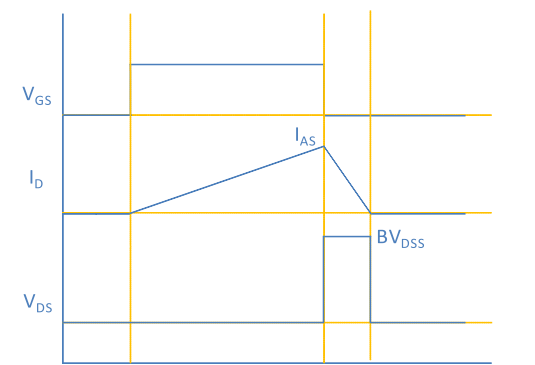
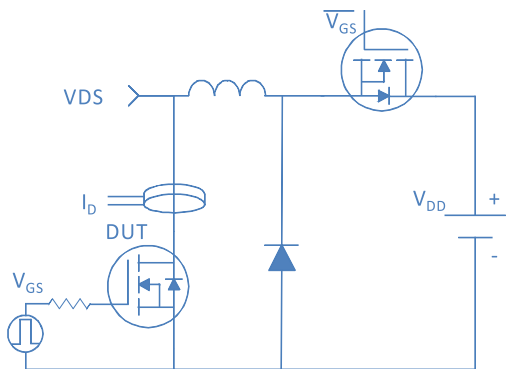

### Diode Recovery Test

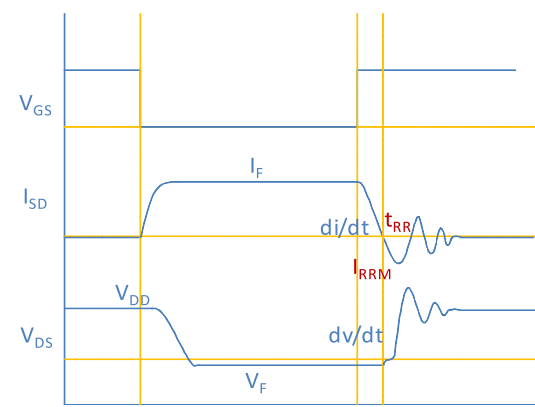
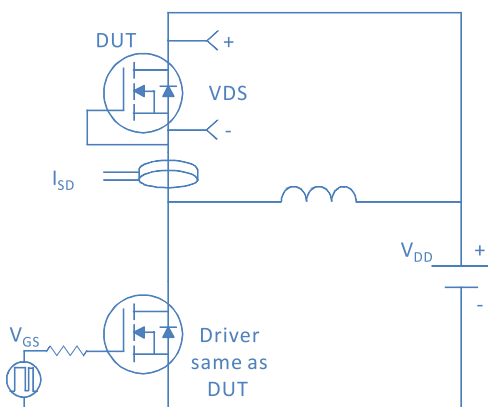

Package Outline

TO-220, 3 leads

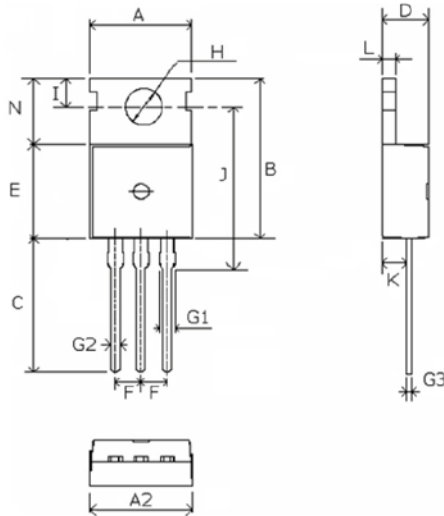

Dimensions in mm unless otherwise specified

Symbol	Min	Nom	Max
A	9.66	9.97	10.28
A2	9.80	10.00	10.20
B	15.60	15.70	15.80
C	12.70	13.48	14.27
D	4.30	4.50	4.70
E	9.00	9.20	9.40
F		2.54	
G1	1.32	1.52	1.72
G2	0.70	0.82	0.95
G3	0.45	0.52	0.60
H	3.50	3.60	3.70
I	2.70	2.80	2.90
J	15.70	15.97	16.25
K	2.20	2.40	2.60
L	1.15	1.27	1.40
N	6.40	6.60	6.80

TO-263, 2 leads

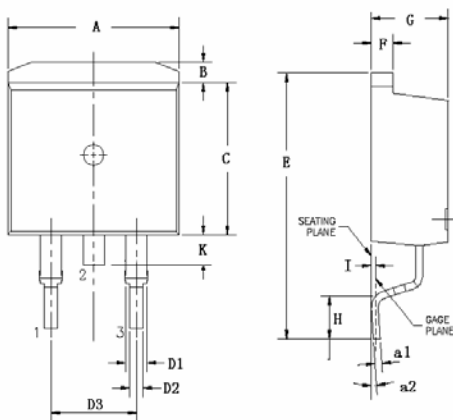

Dimensions in mm unless otherwise specified

Symbol	Min	Nom	Max
A	9.66	9.97	10.28
B	1.02	1.17	1.32
C	8.59	9.00	9.40
D1	1.14	1.27	1.40
D2	0.70	0.83	0.95
D3		5.08	
E	15.09	15.24	15.39
F	1.15	1.28	1.40
G	4.30	4.50	4.70
H	2.29	2.54	2.79
I		0.25	
K	1.30	1.45	1.60
a1	0.45	0.55	0.65
a2(degree)	0°		8°

Package Outline

TO-247, 3 leads

