

DESCRIPTION

The HI-8787 and HI-8788 are system components for interfacing 16 bit parallel data to an ARINC 429 bus. They combine logic and line driver on one chip. The HI-8787 has an output resistance of 37.5 ohms, and the HI-8788 has an output resistance of 10 ohms to facilitate external lightning protection circuitry. The technology is analog/digital CMOS.

Both products offer high speed data bus transactions into a buffer register. After loading 2 16-bit words, data is automatically transferred and transmitted. The data rate is equal to the clock rate. Parity can be enabled in the 32nd bit. Reset is used to initialize the logic upon startup. Word gaps are automatically sent.

The part requires +/- 10 volt supplies in addition to a 5 volt supply.

PIN CONFIGURATION

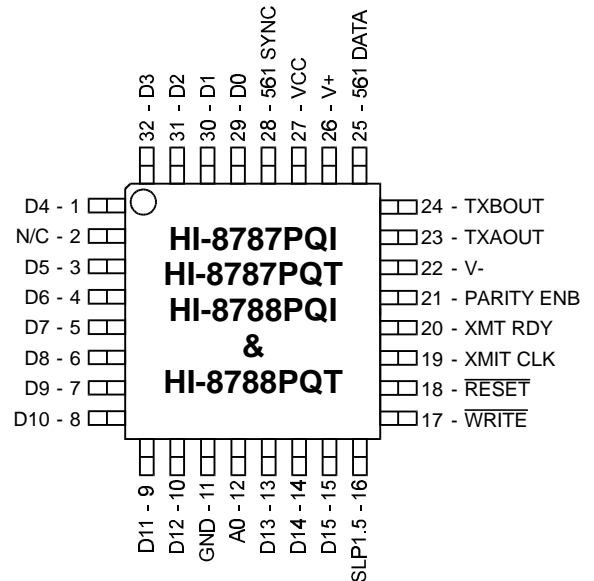

32-Pin Plastic TQFP package

FEATURES

- Automatically converts 16 bit parallel data to ARINC 429 or 561 data
- High speed data bus interface
- On-chip line driver
- Available in small TQFP package
- Military processing options

PIN DESCRIPTIONS

PIN	SYMBOL	FUNCTION	DESCRIPTION
28	561 SYNC	digital output	ARINC 561 Sync signal
1, 3-10,13-15, 29-32	Dn	digital inputs	Parallel 16 bit bus input
11	GND	power supply	Ground
12	A0	digital input	Load address, A0=0 for 1st data load, A0=1 for 2nd data load
16	SLP1.5	digital input	Selects the slope of the line driver. High=1.5us
17	WRITE	digital input	Write strobe. Loads data on rising edge.
18	RESET	digital input	Registers and sequencing logic initialized when low
19	XMIT CLK	digital input	Clock input for the transmitter
20	XMT RDY	digital output	Goes high if the buffer register is empty
21	PARITY ENB	digital input	When high the 32nd bit output is odd parity
22	V-	power supply	-10 volt rail
23	TXAOUT	analog output	Line driver output - A side
24	TXBOUT	analog output	Line driver output - B side
25	561 DATA	digital output	Serial output for ARINC 561 data
26	V+	power supply	+10 volt rail
27	VCC	power supply	+5 volt rail, "one" level out of line driver, inverted for "zero"

FUNCTIONAL DESCRIPTION

The HI-8787 is a parallel to serial converter, which when loaded with two 16 bit parallel words, outputs the data as a 32 bit serial word. Timing circuitry inserts a 4 bit gap at the end of each 32 bit word. An input buffer register allows load operations to take place while the previously loaded word is being transmitted.

If the PARITY ENB pin is high, the 32nd bit will be a parity bit, inserted so as to make the 32 bit word have odd parity. If the PARITY ENB pin is low, the 32nd bit will be the D15 bit of the 2nd word loaded.

Outputs are provided for both ARINC 429 (TXAOUT and TXBOUT pins), and ARINC 561 (561 DATA and 561 SYNC pins) type data.

A low signal applied to the RESET pin resets the HI-8787's internal logic so that spurious transmission does not take place during power-up. The registers are cleared so that a continuous gap will be transmitted until the first word is loaded into the transmitter.

The XMIT CLK frequency is the same as the data rate.

Input data can be loaded when the XMT RDY signal is high, which indicates the input buffer register is empty. The first 16 bit word is loaded with the A0 input high. The second word is loaded with A0 in the low state. Each data word is loaded into the input buffer register by a low pulse on the WRITE input. (See figure 1). After the second word has been loaded, the XMT RDY output goes low. The contents of the input buffer register are transferred to the output register during the fourth bit period of the gap. If the fourth gap bit period of the previous word has already been transmitted, the contents of the input buffer register will be transferred to the output shift register during the first bit period after the second data load, and the XMT RDY output goes high.

After the output shift register is loaded, the data is shifted out to the output logic in the order shown in figure 2.

The 561 SYNC output pulses low when the XMIT CLK is low during the 8th bit of the ARINC transmission.

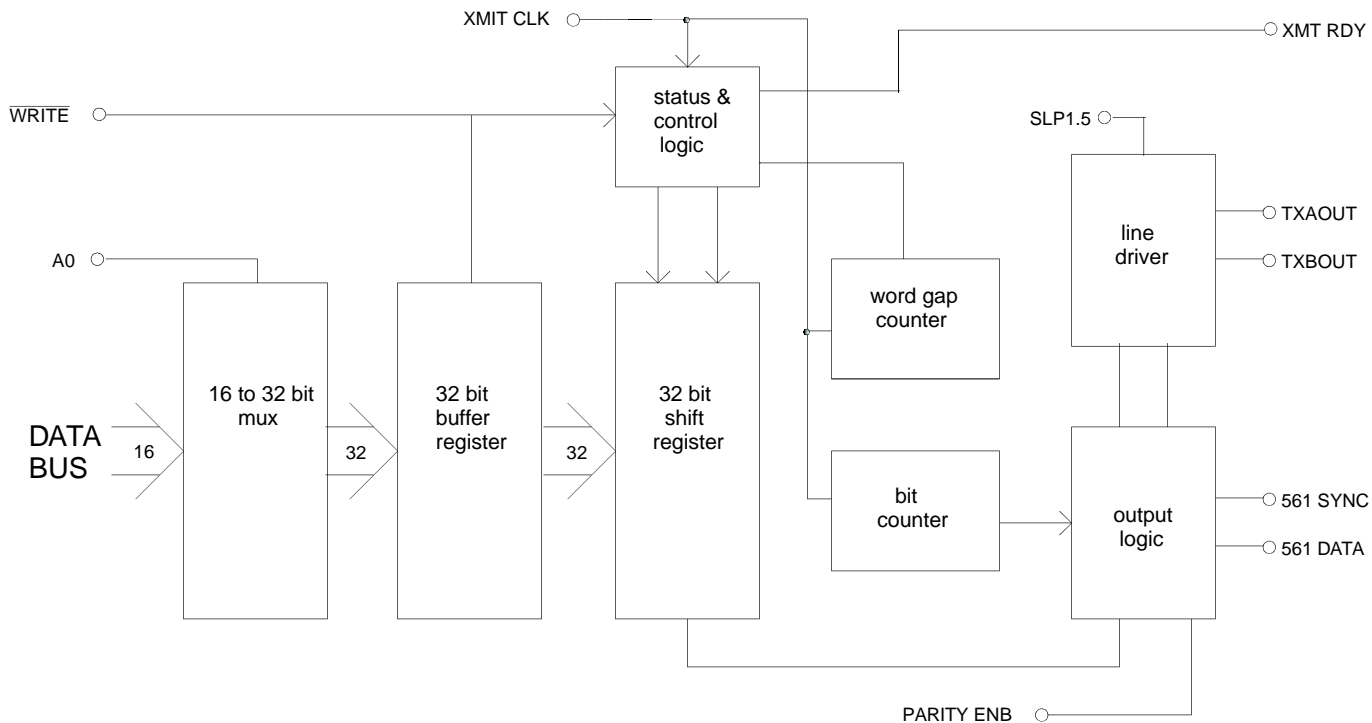

Figure 1. Block Diagram

FUNCTIONAL DESCRIPTION (Cont.)

The HI-8787 and HI-8788 have an on-chip line driver designed to directly drive the ARINC 429 bus. The two ARINC outputs (TXAOUT and TXBOUT) provide a differential voltage to produce a +10 volt One, a -10 volt Zero, and a 0 volt Null. The slope of the ARINC outputs is controlled by the SLP1.5 pin. If SLP1.5 is high, the output rise and fall time is nominally 1.5µs. If SLP1.5 is set low, the rise and fall times are 10µs.

The HI-8787 has 37.5 ohms in series with each line driver output. The HI-8788 has 10.0 ohms in series. The HI-8788 is for applications where external series resistance is needed, typically for lightning protection devices.

A0	Load	Data Bus	ARINC Bits
1	Word 1	D0 - D15	ARINC 1 - ARINC 16
0	Word 2	D0 - D15	ARINC 17 - ARINC 32

Figure 2. Order of transmitted data

DATA TRANSMISSION - EXAMPLE PATTERN

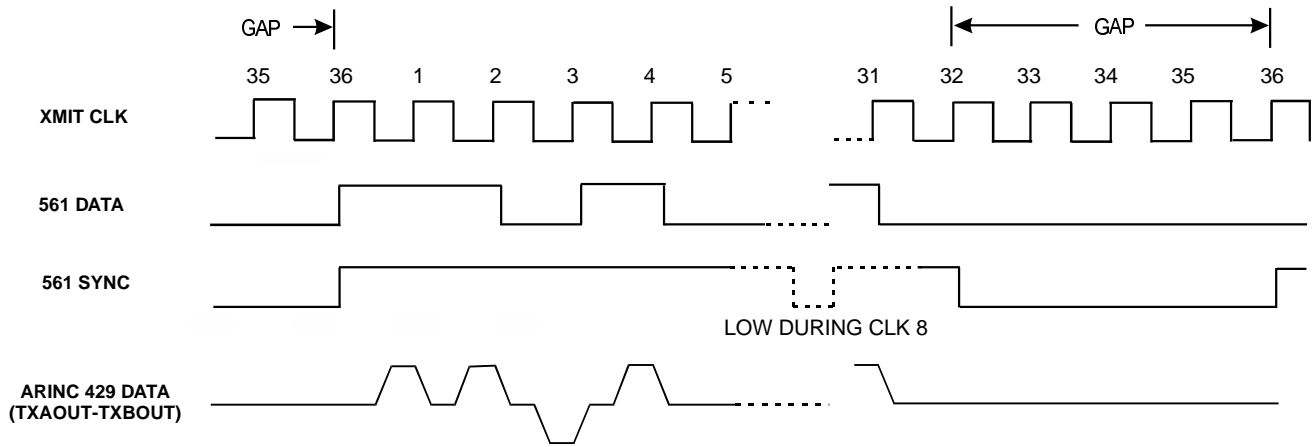

TRANSMITTER OPERATION

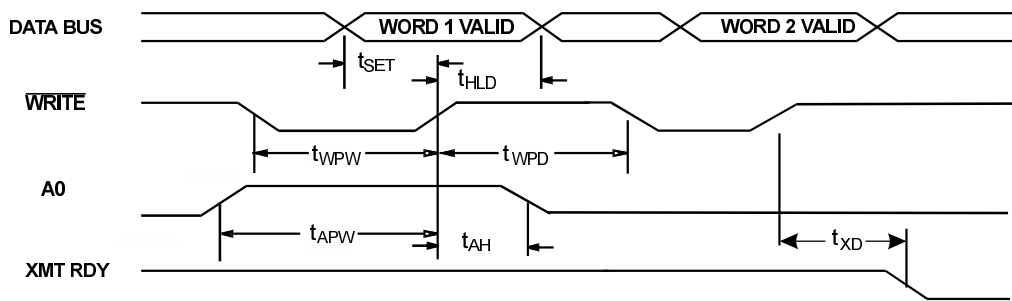

LINE DRIVER OUTPUTS

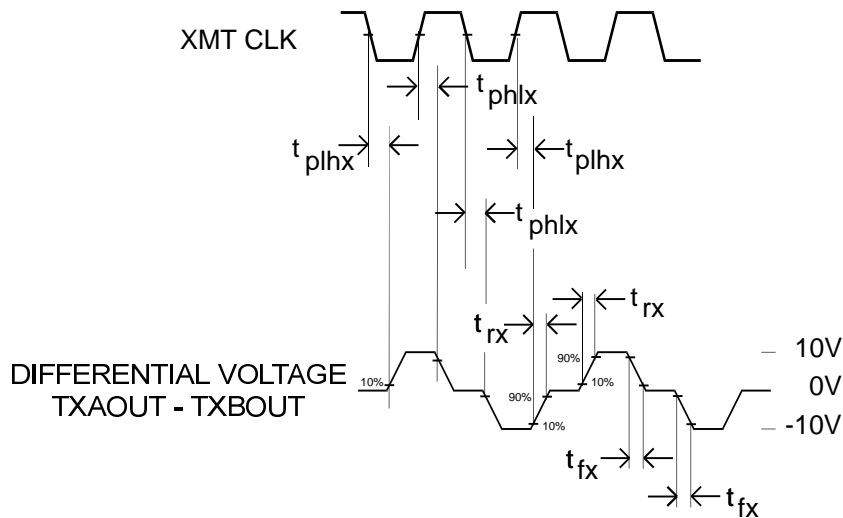

ABSOLUTE MAXIMUM RATINGS

Voltages referenced to Ground

Supply voltages	
V+.....	12.5V
V-.....	-12.5V
VCC.....	7V
DC current per input pin.....	+10ma
Power dissipation at 25°	
plastic DIL.....	1.0W, derate 10mW/°C
ceramic DIL.....	0.5W, derate 7mW/°C
Solder Temperature	275°C for 10 sec
Storage Temperature.....	-65°C to +150°C

RECOMMENDED OPERATING CONDITIONS

Supply Voltages	
V+.....	+10V... ±5%
V-.....	-10V... ±5%
VCC.....	5V... ±5%
Temperature Range	
Industrial Screening.....	-40°C to +85°C
Hi-Temp Screening.....	-55°C to +125°C
Military Screening.....	-55°C to +125°C

NOTE: Stresses above absolute maximum ratings or outside recommended operating conditions may cause permanent damage to the device. These are stress ratings only. Operation at the limits is not recommended.

DC ELECTRICAL CHARACTERISTICS

VCC = 5.0V, VSS = 0V, V+ = 10V, V- = -10V, TA = Operating Temperature Range (unless otherwise specified).

PARAMETER	SYMBOL	CONDITION	MIN	TYP	MAX	UNITS
Operating Voltage	Vcc		4.75	5	5.25	V
Operating Voltage	V+		9.5	10	10.5	V
Operating Voltage	V-		-9.5	-10	10.5	V
Min. Input Voltage (HI)	V _{IH}		2.0	1.4		V
Max. Input Voltage (LO)	V _{IL}			1.4	0.7	V
Min. Input Current (HI)	I _{IH}	V _{IH} = 4.9V			280	µA
Max. Input Current (LO)	I _{IL}	V _{IL} = 0.1V	-1			µA
Min. Output Voltage (HI)	V _{OH}	I _{OUT} = -1.6mA	2.7			V
Max. Output Voltage (LO)	V _{IH}	I _{OUT} = 1.6mA			0.4	V
Line Driver Output Levels (Ref. To GND)						
ONE		no load, VCC = 5.0V	4.5	5.0	5.5	V
NULL		"	-0.25	0	0.25	V
ZERO		"	-5.5	-5.0	-4.5	V
Line Driver Output Levels (Differential TXAOUT - TXBOUT)						
ONE		no load, VCC = 5.0V	9.0	10.0	11.0	V
NULL		"	-0.5	0	0.5	V
ZERO		"	-11.0	-10.0	-9.0	V
Minimum Short Circuit Sink or Source Current	I _{OUT}	momentary magnitude	80			mA
Operating Current Drain	I _{CC}	f = 100khz		0.8	2.8	mA
Operating Current Drain (V+)	I _{DD}	f = 100khz		6	20	mA
Operating Current Drain (V-)	I _{EE}	f = 100khz	-20	-6		mA
Input Capacitance	C _{IN}	Not tested			20	pF

AC ELECTRICAL CHARACTERISTICS

VCC = 5.0V, V+ = 10V, V- = -10V, VSS = 0V, TA = Operating Temperature Range (unless otherwise specified).

PARAMETER	SYMBOL	TEST CONDITIONS	MIN	TYP	MAX	UNITS
DATA BUS TIMING						
Setup Data Bus to $\overline{\text{WRITE}}$	tSET		20			ns
Hold $\overline{\text{WRITE}}$ to Data Bus	tHLD		0			ns
Hold A0 to $\overline{\text{WRITE}}$	tAH		0			ns
Pulse width $\overline{\text{WRITE}}$	tWPW		40			ns
Pulse width A0	tAPW		40			ns
Delay last $\overline{\text{WRITE}}$ to XMT RDY	tXD		40			ns
LINE DRIVER TIMING						
Line Driver propagation delay		No load				
Output high to low	tphx		-	500	-	ns
Output low to high	tplx		-	500	-	ns
Line Driver transition times						
Output high to low	t fx	SLP1.5 = logic 1	1.0	1.5	2.0	μs
Output low to high	t rx	SLP1.5 = logic 1	1.0	1.5	2.0	μs
Output high to low	t fx	SLP1.5 = logic 0	5	10	15	μs
Output low to high	t rx	SLP1.5 = logic 0	5	10	15	μs

ORDERING INFORMATION

PART NUMBER	INCLUDES LINE DRIVER	OUTPUT RESISTOR	PACKAGE DESCRIPTION	TEMPERATURE RANGE	PROCESS FLOW	LEAD FINISH
HI-8787PQI	YES	37.5 ohm	32 Pin Plastic TQFP	-40°C TO +85°C	I	SOLDER
HI-8787PQT	YES	37.5 ohm	32 Pin Plastic TQFP	-55°C TO +125°C	T	SOLDER
HI-8788PQI	YES	10.0 ohm	32 Pin Plastic TQFP	-40°C TO +85°C	I	SOLDER
HI-8788PQT	YES	10.0 ohm	32 Pin Plastic TQFP	-55°C TO +125°C	T	SOLDER

32 PIN PLASTIC THIN QUAD FLAT PACK (TQFP)

Package Type: 32PTQS

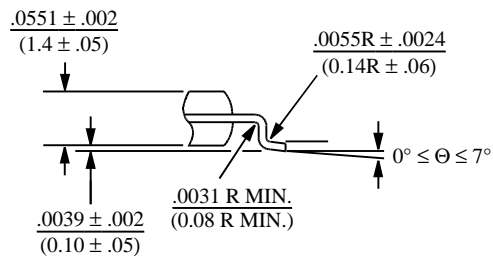
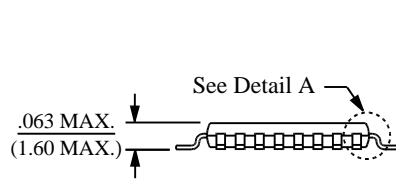
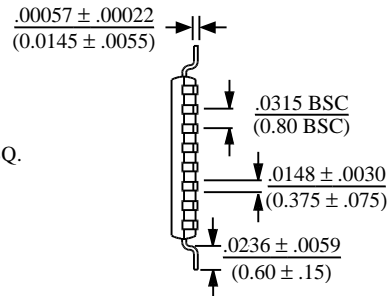
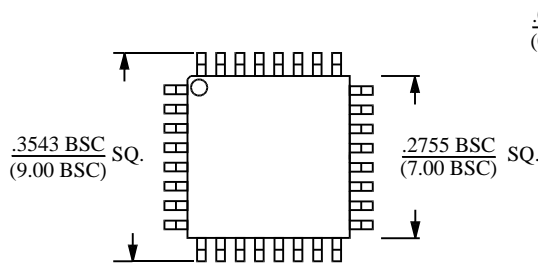

Detail A