

**12-Bit, 10 MSPS A/D Converter**

The HI5808 is a monolithic, 12-bit, Analog-to-Digital Converter fabricated in Intersil's HBC10 BiCMOS process. It is designed for high speed, high resolution applications where wide bandwidth and low power consumption are essential.

The HI5808 is designed in a fully differential pipelined architecture with a front end differential-in-differential-out sample-and-hold (S/H). The HI5808 has excellent dynamic performance while consuming 325mW power at 10 MSPS.

The 100MHz full power input bandwidth is ideal for communication systems and document scanner applications. Data output latches are provided which present valid data to the output bus with a latency of 3 clock cycles. The digital outputs have a separate supply pin which can be powered from a 3V to 5V supply.

**Ordering Information**

PART NUMBER	SAMPLE RATE	TEMP. RANGE (°C)	PACKAGE	PKG. NO.
HI5808BIB	10 MSPS	-40 to 85	28 Ld SOIC	M28.3
HI5808EVAL1		25	Evaluation Board	

**Pinout**

**HI5808  
(SOIC)  
TOP VIEW**

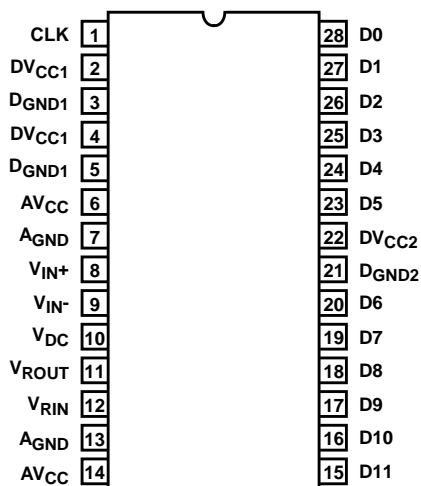

**Features**

- Sampling Rate . . . . . 10 MSPS
- Low Power
- Internal Sample and Hold
- Fully Differential Architecture
- Full Power Input Bandwidth . . . . . 100MHz
- Low Distortion
- Internal Voltage Reference
- TTL/CMOS Compatible Digital I/O
- Digital Outputs . . . . . 5V to 3.0V

**Applications**

- Digital Communication Systems
- Undersampling Digital IF
- Document Scanners
- Additional Reference Documents
  - AN9214 Using Intersil High Speed A/D Converters
  - AN9724 Using the HI5808EVAL1 Evaluation Board

Functional Block Diagram

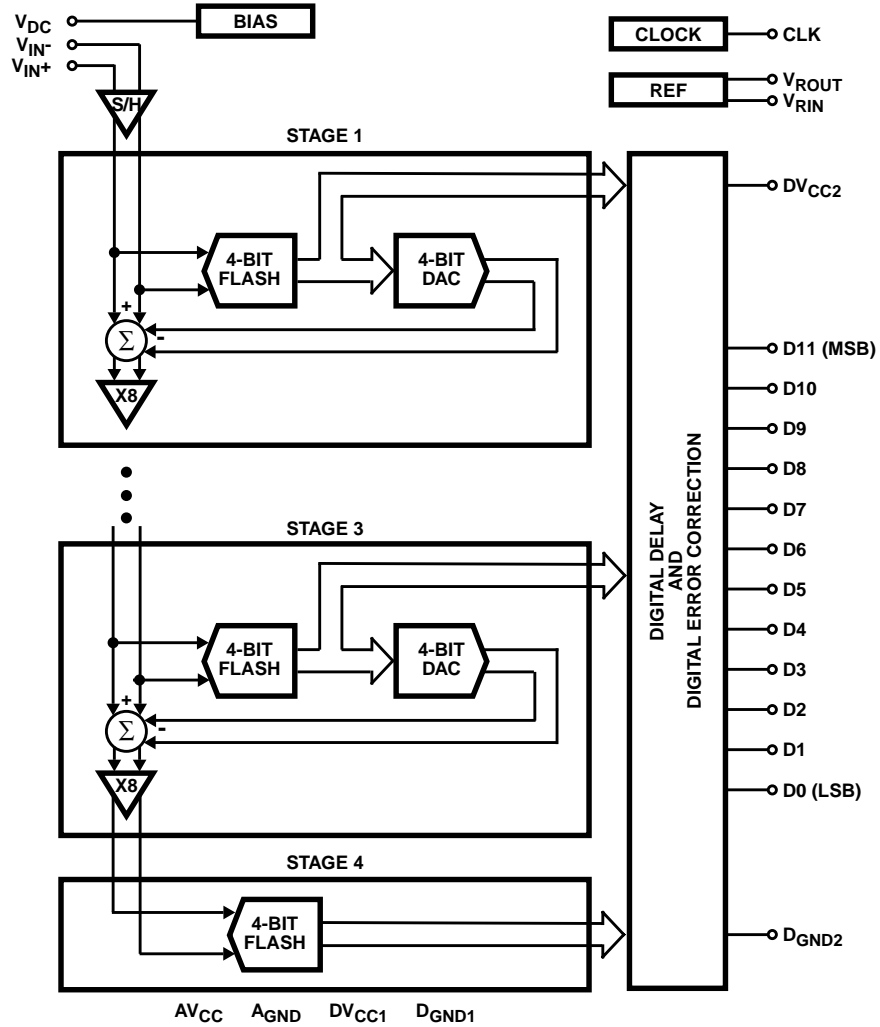

Typical Applications Schematic

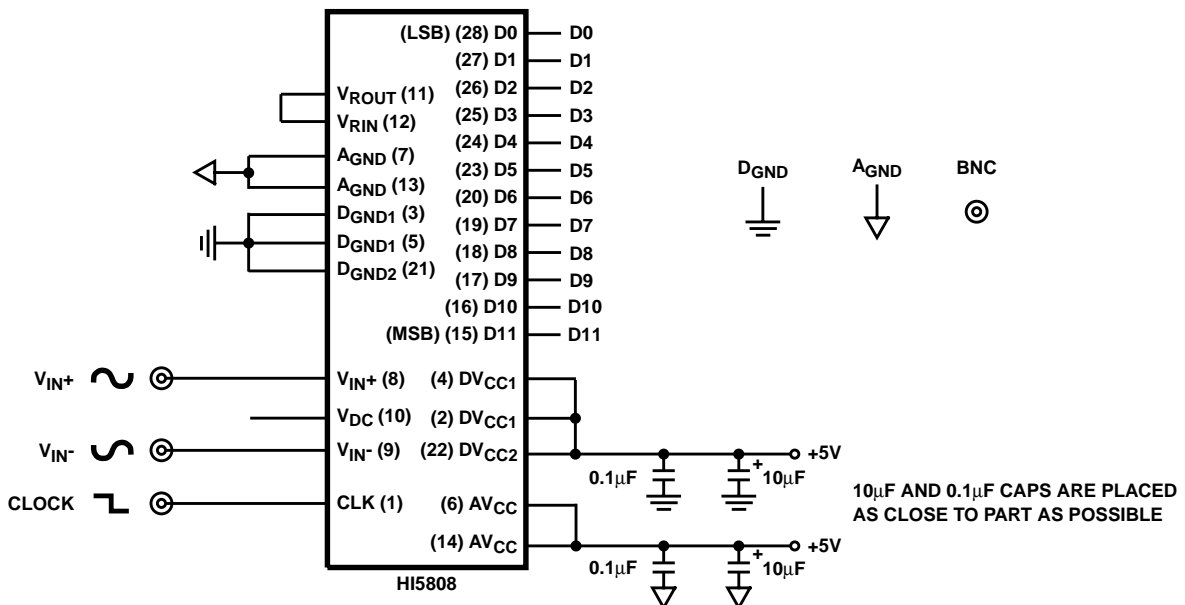

## Absolute Maximum Ratings

Supply Voltage,  $AV_{CC}$  or  $DV_{CC}$  to  $AGND$  or  $DGND$  ..... +6.0V  
 $DGND$  to  $AGND$  ..... 0.3V  
 Digital I/O Pins .....  $DGND$  to  $DV_{CC}$   
 Analog I/O Pins .....  $AGND$  to  $AV_{CC}$

## Operating Conditions

Temperature Range ..... -40°C to 85°C

*CAUTION: Stresses above those listed in "Absolute Maximum Ratings" may cause permanent damage to the device. This is a stress only rating and operation of the device at these or any other conditions above those indicated in the operational sections of this specification is not implied.*

### NOTE:

- $\theta_{JA}$  is measured with the component mounted on an evaluation PC board in free air.

## Thermal Information

Thermal Resistance (Typical, Note 1)  $\theta_{JA}$  (°C/W)  
 SOIC Package ..... 70  
 Maximum Junction Temperature ..... 150°C  
 Maximum Storage Temperature Range ..... -65°C to 150°C  
 Lead Temperature (Soldering, 10s) ..... 300°C  
 (SOIC - Lead Tips Only)

**Electrical Specifications**  $AV_{CC} = DV_{CC1} = DV_{CC2} = +5V$ ,  $f_S = 10$  MSPS at 50% Duty Cycle,  $V_{RIN} = 3.5V$ ,  $C_L = 10pF$ ,  
 $T_A = -40^\circ C$  to  $85^\circ C$ , Differential Analog Input, Typical Values are Test Results at  $25^\circ C$ ,  
 Unless Otherwise Specified

PARAMETER	TEST CONDITIONS	HI5808BIB -40°C TO 85°C			UNITS
		MIN	TYP	MAX	
<b>ACCURACY</b>					
Resolution		12	-	-	Bits
Integral Linearity Error, INL	$f_{IN} = DC$	-	$\pm 1$	$\pm 2$	LSB
Differential Linearity Error, DNL (Guaranteed No Missing Codes)	$f_{IN} = DC$	-	$\pm 0.5$	$\pm 1$	LSB
Offset Error, $V_{OS}$	$f_{IN} = DC$	-	19	-	LSB
Full Scale Error, FSE	$f_{IN} = DC$	-	32	-	LSB
<b>DYNAMIC CHARACTERISTICS</b>					
Minimum Conversion Rate	No Missing Codes	-	0.5	-	MSPS
Maximum Conversion Rate	No Missing Codes	10	-	-	MSPS
Effective Number of Bits, ENOB	$f_{IN} = 1MHz$	10.0	10.8	-	Bits
Signal to Noise and Distortion Ratio, SINAD = $\frac{RMS\ Signal}{RMS\ Noise + Distortion}$	$f_{IN} = 1MHz$	-	66.5	-	dB
Signal to Noise Ratio, SNR = $\frac{RMS\ Signal}{RMS\ Noise}$	$f_{IN} = 1MHz$	-	67.3	-	dB
Total Harmonic Distortion, THD	$f_{IN} = 1MHz$	-	-75	-	dBc
2nd Harmonic Distortion	$f_{IN} = 1MHz$	-	-80	-	dBc
3rd Harmonic Distortion	$f_{IN} = 1MHz$	-	-77	-	dBc
Spurious Free Dynamic Range, SFDR	$f_{IN} = 1MHz$	-	77	-	dBc
Intermodulation Distortion, IMD	$f_1 = 1MHz, f_2 = 1.02MHz$	-	-65	-	dBc
Transient Response		-	1	-	Cycle
Over-Voltage Recovery	0.2V Overdrive	-	2	-	Cycle
<b>ANALOG INPUT</b>					
Maximum Peak-to-Peak Differential Analog Input Range ( $V_{IN+} - V_{IN-}$ )		-	$\pm 2.0$	-	V
Maximum Peak-to-Peak Single-Ended Analog Input Range		-	4.0	-	V
Analog Input Resistance, $R_{IN}$	(Notes 2, 3)	1	-	-	M $\Omega$
Analog Input Capacitance, $C_{IN}$		-	10	-	pF
Analog Input Bias Current, $I_{B+}$ or $I_{B-}$	(Note 3)	-10	-	+10	$\mu A$
Differential Analog Input Bias Current $I_{B\ DIFF} = (I_{B+} - I_{B-})$		-	$\pm 0.5$	-	$\mu A$
Full Power Input Bandwidth, FPBW		-	100	-	MHz

# HI5808

**Electrical Specifications**  $AV_{CC} = DV_{CC1} = DV_{CC2} = +5V$ ,  $f_S = 10$  MSPS at 50% Duty Cycle,  $V_{RIN} = 3.5V$ ,  $C_L = 10pF$ ,  
 $T_A = -40^{\circ}C$  to  $85^{\circ}C$ , Differential Analog Input, Typical Values are Test Results at  $25^{\circ}C$ ,  
 Unless Otherwise Specified **(Continued)**

PARAMETER	TEST CONDITIONS	HI5808BIB -40°C TO 85°C			UNITS
		MIN	TYP	MAX	
Analog Input Common Mode Voltage Range ( $V_{IN+} + V_{IN-}/2$ )	Differential Mode (Note 2)	1	2.3	4	V
<b>INTERNAL VOLTAGE REFERENCE</b>					
Reference Output Voltage, $V_{ROUT}$ (Loaded)		-	3.5	-	V
Reference Output Current		-	-	1	mA
Reference Temperature Coefficient		-	50	-	ppm/°C
<b>REFERENCE VOLTAGE INPUT</b>					
Reference Voltage Input, $V_{RIN}$		-	3.5	-	V
Total Reference Resistance, $R_L$		-	7.8	-	kΩ
Reference Current		-	450	-	μA
<b>DC BIAS VOLTAGE</b>					
DC Bias Voltage Output, $V_{DC}$		-	2.3	-	V
Max Output Current (Not To Exceed)		-	-	1	mA
<b>DIGITAL INPUTS (CLK)</b>					
Input Logic High Voltage, $V_{IH}$		2.0	-	-	V
Input Logic Low Voltage, $V_{IL}$		-	-	0.8	V
Input Logic High Current, $I_{IH}$	$V_{CLK} = 5V$	-	-	10.0	μA
Input Logic Low Current, $I_{IL}$	$V_{CLK} = 0V$	-	-	10.0	μA
Input Capacitance, $C_{IN}$		-	7	-	pF
<b>DIGITAL OUTPUTS (D0-D11)</b>					
Output Logic Sink Current, $I_{OL}$	$V_O = 0.4V$ (Note 2)	1.6	-	-	mA
	$DV_{CC3} = 3.0V$ , $V_O = 0.4V$	-	1.6	-	mA
Output Logic Source Current, $I_{OH}$	$V_O = 2.4V$ (Note 2)	-0.2	-	-	mA
	$DV_{CC3} = 3.0V$ , $V_O = 2.4V$	-	-0.2	-	mA
Output Capacitance, $C_{OUT}$		-	5	-	pF
<b>TIMING CHARACTERISTICS</b>					
Aperture Delay, $t_{AP}$		-	5	-	ns
Aperture Jitter, $t_{AJ}$		-	5	-	ps (RMS)
Data Output Delay, $t_{OD}$		-	8	-	ns
Data Output Hold, $t_H$		-	8	-	ns
Data Latency, $t_{LAT}$	For a Valid Sample (Note 2)	-	-	3	Cycles
Clock Pulse Width (Low)	10 MSPS Clock	45	50	55	ns
Clock Pulse Width (High)	10 MSPS Clock	45	50	55	ns
<b>POWER SUPPLY CHARACTERISTICS</b>					
Total Supply Current, $I_{CC}$	$V_{IN+} - V_{IN-} = 2V$	-	65	73	mA
Analog Supply Current, $AI_{CC}$	$V_{IN+} - V_{IN-} = 2V$	-	46	-	mA
Digital Supply Current, $DI_{CC1}$	$V_{IN+} - V_{IN-} = 2V$	-	17	-	mA
Output Supply Current, $DI_{CC2}$	$V_{IN+} - V_{IN-} = 2V$	-	2	-	mA
Power Dissipation	$V_{IN+} - V_{IN-} = 2V$	-	325	365	mW
Offset Error PSRR, $\Delta V_{OS}$	$AV_{CC}$ or $DV_{CC} = 5V \pm 5\%$	-	2	-	LSB
Gain Error PSRR, $\Delta FSE$	$AV_{CC}$ or $DV_{CC} = 5V \pm 5\%$	-	30	-	LSB

NOTES:

- Parameter guaranteed by design or characterization and not production tested.
- With the clock off (clock low, hold mode).

Timing Waveforms

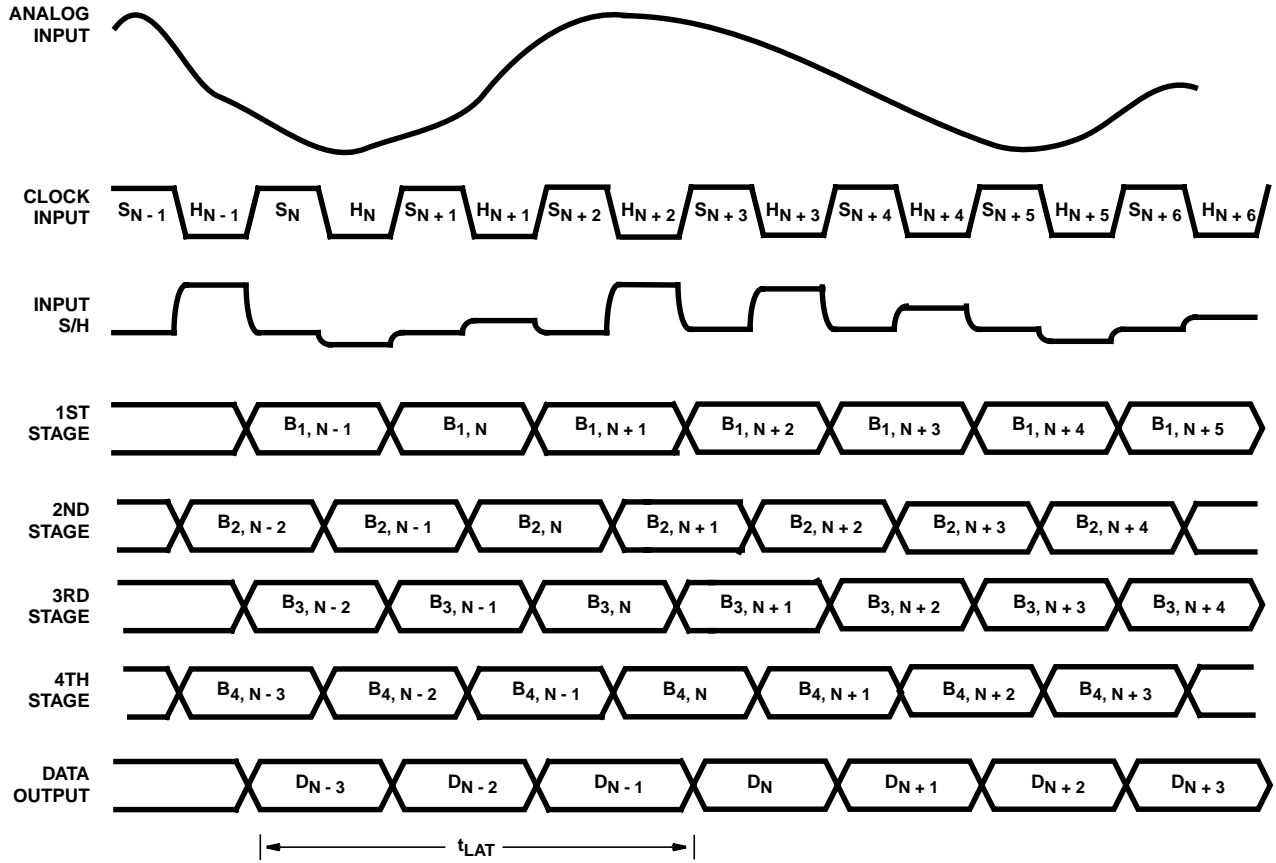

NOTES:

4.  $S_N$ : N-th sampling period.
5.  $H_N$ : N-th holding period.
6.  $B_{M, N}$ : M-th stage digital output corresponding to N-th sampled input.
7.  $D_N$ : Final data output corresponding to N-th sampled input.

FIGURE 1. INTERNAL CIRCUIT TIMING

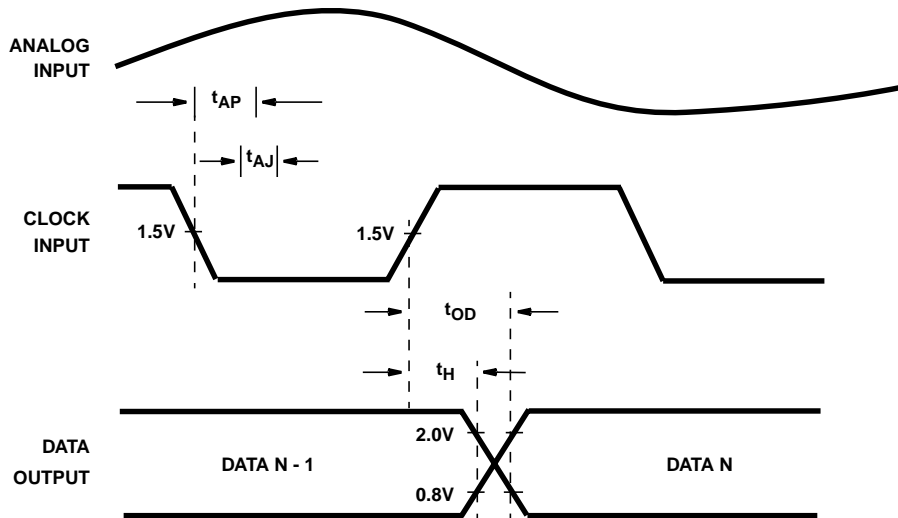

FIGURE 2. INPUT-TO-OUTPUT TIMING

Typical Performance Curves

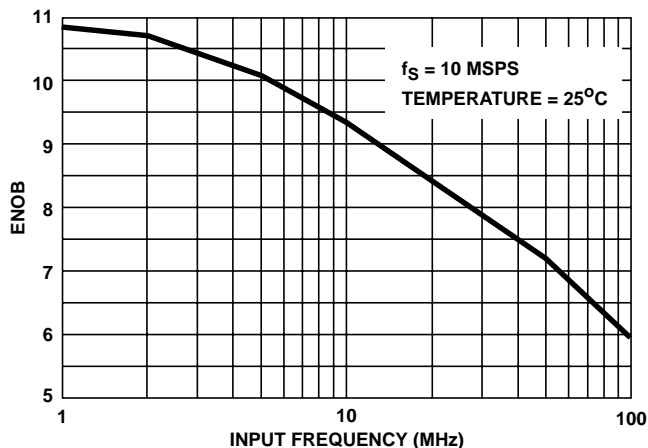

FIGURE 3. EFFECTIVE NUMBER OF BITS (ENOB) vs INPUT FREQUENCY

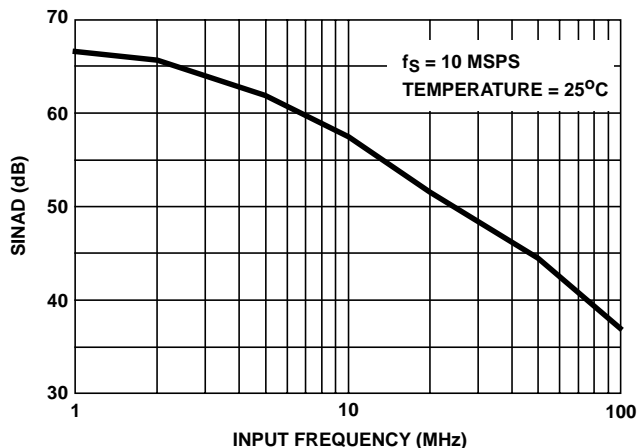

FIGURE 4. SIGNAL TO NOISE AND DISTORTION (SINAD) vs INPUT FREQUENCY

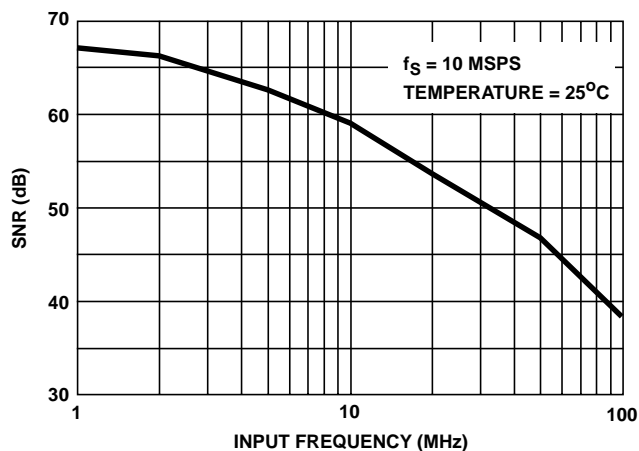

FIGURE 5. SIGNAL TO NOISE RATIO (SNR) vs INPUT FREQUENCY

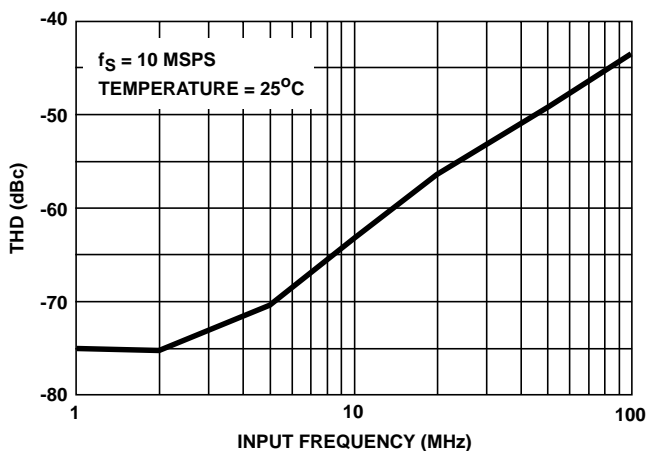

FIGURE 6. TOTAL HARMONIC DISTORTION (THD) vs INPUT FREQUENCY

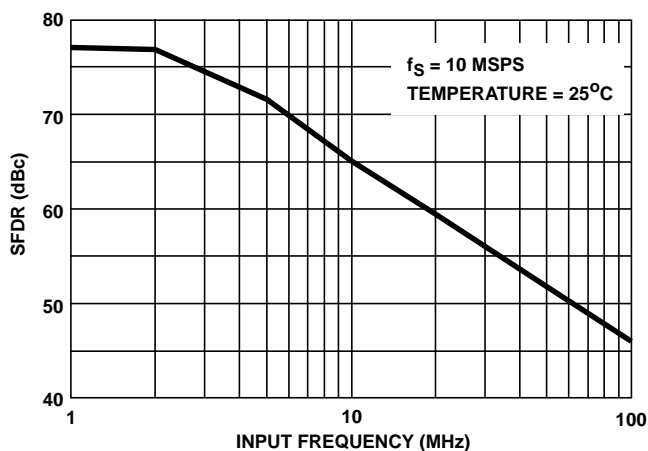

FIGURE 7. SPURIOUS FREE DYNAMIC RANGE (SFDR) vs INPUT FREQUENCY

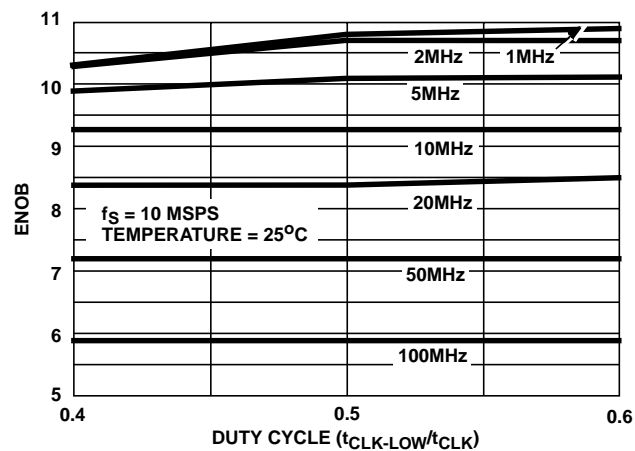

FIGURE 8. EFFECTIVE NUMBER OF BITS (ENOB) vs CLOCK DUTY CYCLE AND INPUT FREQUENCY

Typical Performance Curves (Continued)

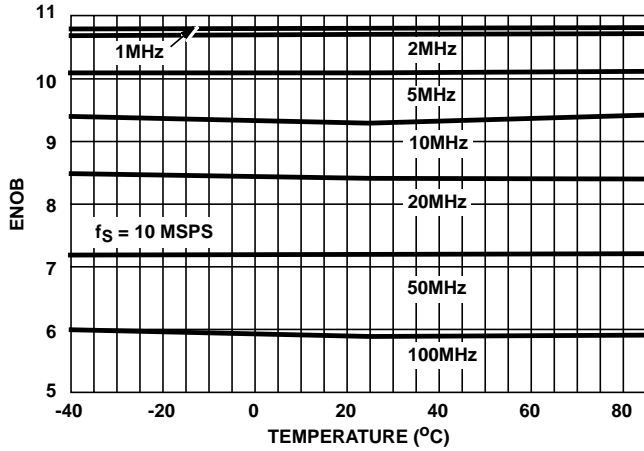

FIGURE 9. EFFECTIVE NUMBER OF BITS (ENOB) vs TEMPERATURE AND INPUT FREQUENCY

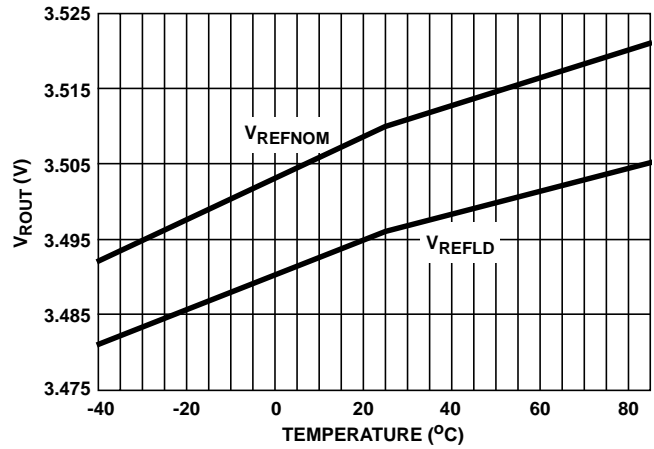

FIGURE 10. INTERNAL VOLTAGE REFERENCE OUTPUT ( $V_{ROUT}$ ) vs TEMPERATURE AND LOAD

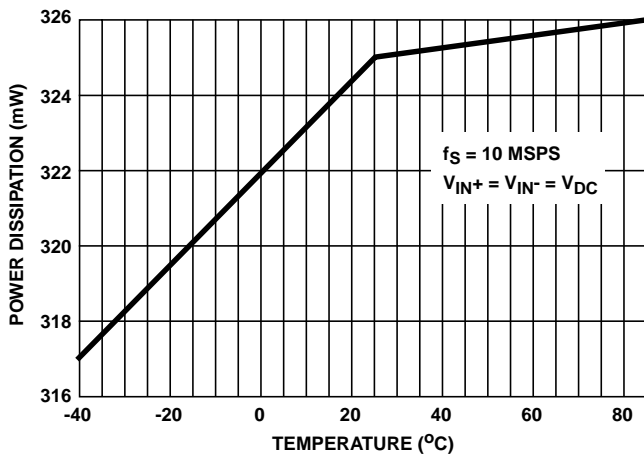

FIGURE 11. POWER DISSIPATION vs TEMPERATURE

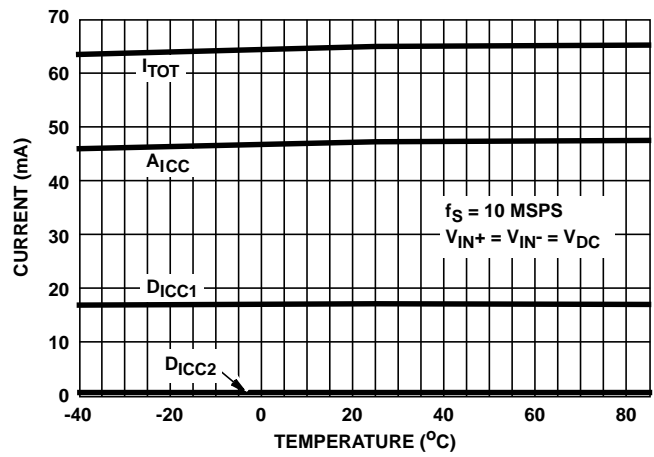

FIGURE 12. POWER SUPPLY CURRENT vs TEMPERATURE

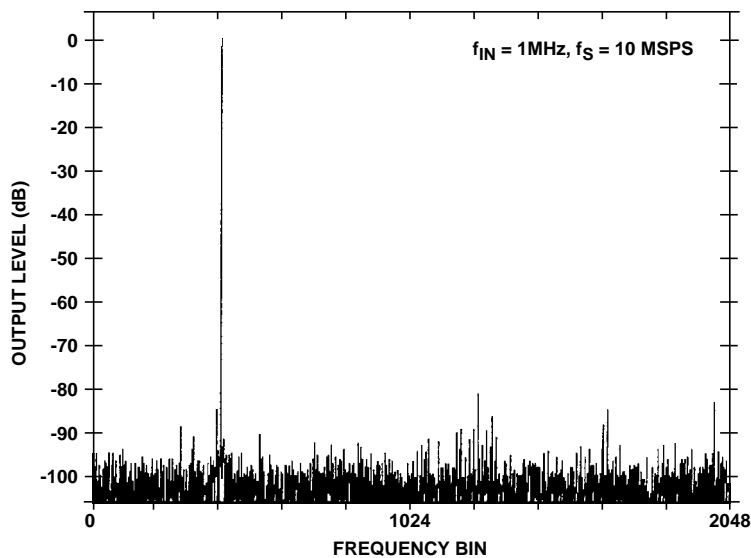

FIGURE 13. 4096 POINT FFT SPECTRAL PLOT

**Pin Descriptions**

PIN NO.	NAME	DESCRIPTION
1	CLK	Sample Clock Input.
2	DV <sub>CC1</sub>	Digital Supply (5.0V).
3	D <sub>GND1</sub>	Digital Ground.
4	DV <sub>CC1</sub>	Digital Supply (5.0V).
5	D <sub>GND1</sub>	Digital Ground.
6	AV <sub>CC</sub>	Analog Supply (5.0V).
7	AG <sub>ND</sub>	Analog Ground.
8	V <sub>IN+</sub>	Positive Analog Input.
9	V <sub>IN-</sub>	Negative Analog Input.
10	V <sub>DC</sub>	DC Bias Voltage Output.
11	V <sub>ROUT</sub>	Reference Voltage Output.
12	V <sub>RIN</sub>	Reference Voltage Input.
13	AG <sub>ND</sub>	Analog Ground.
14	AV <sub>CC</sub>	Analog Supply (5.0V).
15	D11	Data Bit 11 Output (MSB).
16	D10	Data Bit 10 Output.
17	D9	Data Bit 9 Output.
18	D8	Data Bit 8 Output.
19	D7	Data Bit 7 Output.
20	D6	Data Bit 6 Output.
21	D <sub>GND2</sub>	Digital Output Ground.
22	DV <sub>CC2</sub>	Digital Output Supply (3.0V to 5.0V).
23	D5	Data Bit 5 Output.
24	D4	Data Bit 4 Output.
25	D3	Data Bit 3 Output.
26	D2	Data Bit 2 Output.
27	D1	Data Bit 1 Output.
28	D0	Data Bit 0 Output (LSB).

**Detailed Description**

**Theory of Operation**

The HI5808 is a 12-bit fully differential sampling pipeline A/D converter with digital error correction. Figure 14 depicts the circuit for the front end differential-in-differential-out sample-and-hold (S/H). The switches are controlled by an internal clock which is a non-overlapping two phase signal,  $\phi_1$  and  $\phi_2$ , derived from the master clock. During the sampling phase,  $\phi_1$ , the input signal is applied to the sampling capacitors,  $C_S$ . At the same time the holding capacitors,  $C_H$ , are discharged to analog ground. At the falling edge of  $\phi_1$  the input signal is sampled on the bottom plates of the sampling

capacitors. In the next clock phase,  $\phi_2$ , the two bottom plates of the sampling capacitors are connected together and the holding capacitors are switched to the op-amp output nodes. The charge then redistributes between  $C_S$  and  $C_H$  completing one sample-and-hold cycle. The output is a fully-differential, sampled-data representation of the analog input. The circuit not only performs the sample-and-hold function but will also convert a single-ended input to a fully-differential output for the converter core. During the sampling phase, the V<sub>IN</sub> pins see only the on-resistance of a switch and  $C_S$ . The relatively small values of these components result in a typical full power input bandwidth of 100MHz for the converter.

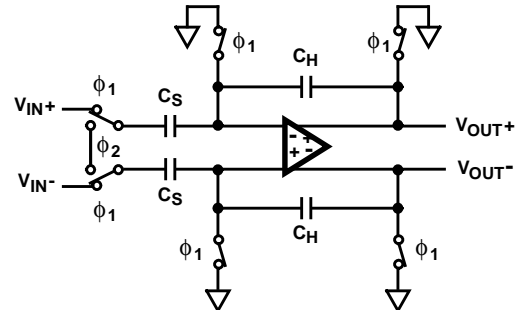

**FIGURE 14. ANALOG INPUT SAMPLE-AND-HOLD**

As illustrated in the functional block diagram and the timing diagram in Figure 1, three identical pipeline subconverter stages, each containing a four-bit flash converter, a four-bit digital-to-analog converter and an amplifier with a voltage gain of 8, follow the S/H circuit with the fourth stage being only a 4-bit flash converter. Each converter stage in the pipeline will be sampling in one phase and amplifying in the other clock phase. Each individual sub-converter clock signal is offset by 180 degrees from the previous stage clock signal, with the result that alternate stages in the pipeline will perform the same operation.

The digital output of each of the three identical 4-bit subconverter stages is a four-bit digital word containing a supplementary bit to be used by the digital error correction logic. The output of each subconverter stage is input to a digital delay line which is controlled by the internal sampling clock. The function of the digital delay line is to time align the digital outputs of the three identical four-bit subconverter stages with the corresponding output of the fourth stage flash converter before applying the sixteen bit result to the digital error correction logic. The digital error correction logic uses the supplementary bits to correct any error that may exist before generating the final twelve bit digital data output of the converter.

Because of the pipeline nature of this converter, the digital data representing an analog input sample is output to the digital data bus on the 3rd cycle of the clock after the analog sample is taken. This time delay is specified as the data latency. After the data latency time, the digital data representing each succeeding analog sample is output on the following clock pulse. The digital output data is synchronized to the external sampling clock with an output latch. The output of the digital error correction circuit is available in offset binary format (see Table 1, A/D Code Table).



TABLE 1. A/D CODE TABLE

CODE CENTER DESCRIPTION	DIFFERENTIAL INPUT VOLTAGE † (USING INTERNAL REFERENCE)	OFFSET BINARY OUTPUT CODE											
		MSB											LSB
		D11	D10	D9	D8	D7	D6	D5	D4	D3	D2	D1	D0
+Full Scale (+FS) - 1/4 LSB	+1.99976V	1	1	1	1	1	1	1	1	1	1	1	1
+FS - 1 1/4 LSB	1.99878V	1	1	1	1	1	1	1	1	1	1	1	0
+ 3/4 LSB	732.4µV	1	0	0	0	0	0	0	0	0	0	0	0
- 1/4 LSB	-244.1µV	0	1	1	1	1	1	1	1	1	1	1	1
-FS + 1 3/4 LSB	-1.99829V	0	0	0	0	0	0	0	0	0	0	0	1
-Full Scale (-FS) + 3/4 LSB	-1.99927V	0	0	0	0	0	0	0	0	0	0	0	0

† The voltages listed above represent the ideal center of each offset binary output code shown.

**Internal Reference Generator, V<sub>ROUT</sub> and V<sub>RIN</sub>**

The HI5808 has an internal reference generator, therefore, no external reference voltage is required. V<sub>ROUT</sub> must be connected to V<sub>RIN</sub> when using the internal reference voltage.

The HI5808 can be used with an external reference. The converter requires only one external reference voltage connected to the V<sub>RIN</sub> pin with V<sub>ROUT</sub> left open.

The HI5808 is tested with V<sub>RIN</sub> equal to 3.5V. Internal to the converter, two reference voltages of 1.3V and 3.3V are generated for a fully differential input signal range of ±2V.

In order to minimize overall converter noise, it is recommended that adequate high frequency decoupling be provided at the reference voltage input pin, V<sub>RIN</sub>.

**Analog Input, Differential Connection**

The analog input to the HI5808 can be configured in various ways depending on the signal source and the required level of performance. A fully differential connection (Figure 15) will give the best performance for the converter.

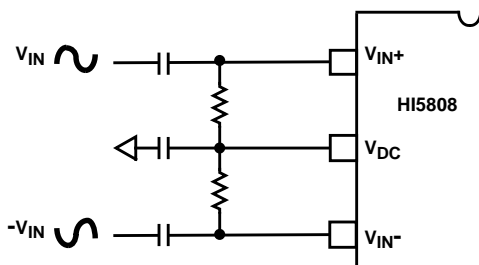

FIGURE 15. AC COUPLED DIFFERENTIAL INPUT

Since the HI5808 is powered off a single +5V supply, the analog input must be biased so it lies within the analog input common mode voltage range of 1.0V to 4.0V. The performance of the ADC does not change significantly with the value of the analog input common mode voltage.

A 2.3V DC bias voltage source, V<sub>DC</sub>, half way between the top and bottom internal reference voltages, is made available to the user to help simplify circuit design when using a differential input. This low output impedance voltage source is not designed to be a reference but makes an excellent bias source and stays within the analog input common mode voltage range over temperature.

The difference between the converter's two internal voltage references is 2V. For the AC coupled differential input, (Figure 15), if V<sub>IN</sub> is a 2V<sub>P-P</sub> sinewave with -V<sub>IN</sub> being 180 degrees out of phase with V<sub>IN</sub>, then V<sub>IN+</sub> is a 2V<sub>P-P</sub> sinewave riding on a DC bias voltage equal to V<sub>DC</sub> and V<sub>IN-</sub> is a 2V<sub>P-P</sub> sinewave riding on a DC bias voltage equal to V<sub>DC</sub>. Consequently, the converter will be at positive full scale, all 1s digital data output code, when the V<sub>IN+</sub> input is at V<sub>DC</sub> +1V and the V<sub>IN-</sub> input is at V<sub>DC</sub> -1V (V<sub>IN+</sub>-V<sub>IN-</sub> = 2V). Conversely, the ADC will be at negative full scale, all 0s digital data output code, when the V<sub>IN+</sub> input is equal to V<sub>DC</sub> -1V and V<sub>IN-</sub> is at V<sub>DC</sub>+1V (V<sub>IN+</sub>-V<sub>IN-</sub> = -2V). From this, the converter is seen to have a peak-to-peak differential analog input voltage range of ±2V.

The analog input can be DC coupled (Figure 16) as long as the inputs are within the analog input common mode voltage range (1.0V ≤ V<sub>DC</sub> ≤ 4.0V).

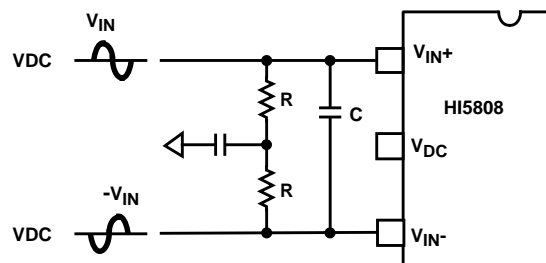

FIGURE 16. DC COUPLED DIFFERENTIAL INPUT

The resistors, R, in Figure 16 are not absolutely necessary but may be used as load setting resistors. A capacitor, C, connected from V<sub>IN+</sub> to V<sub>IN-</sub> will help filter any high

frequency noise on the inputs, also improving performance. Values around 20pF are sufficient and can be used on AC coupled inputs as well. Note, however, that the value of capacitor C chosen must take into account the highest frequency component of the analog input signal.

**Analog Input, Single-Ended Connection**

The configuration shown in Figure 17 may be used with a single ended AC coupled input. Sufficient headroom must be provided such that the input voltage never goes above +5V or below AGND.

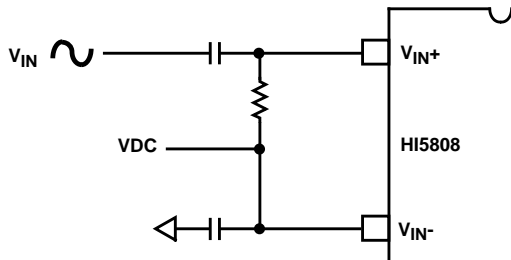

FIGURE 17. AC COUPLED SINGLE ENDED INPUT

Again, the difference between the two internal voltage references is 2V. If  $V_{IN}$  is a 4V<sub>P-P</sub> sinewave, then  $V_{IN+}$  is a 4V<sub>P-P</sub> sinewave riding on a positive voltage equal to V<sub>DC</sub>. The converter will be at positive full scale when  $V_{IN+}$  is at V<sub>DC</sub> + 2V ( $V_{IN+} - V_{IN-} = 2V$ ) and will be at negative full scale when  $V_{IN+}$  is equal to V<sub>DC</sub> - 2V ( $V_{IN+} - V_{IN-} = -2V$ ). In this case, V<sub>DC</sub> could range between 2V and 3V without a significant change in ADC performance. The simplest way to produce V<sub>DC</sub> is to use the V<sub>DC</sub> bias voltage output of the HI5808.

The single ended analog input can be DC coupled (Figure 18) as long as the input is within the analog input common mode voltage range.

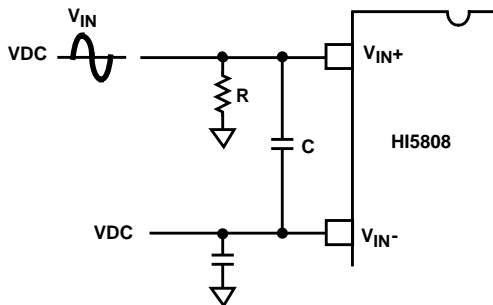

FIGURE 18. DC COUPLED SINGLE ENDED INPUT

The resistor, R, in Figure 18 is not absolutely necessary but may be used as a load setting resistor. A capacitor, C, connected from  $V_{IN+}$  to  $V_{IN-}$  will help filter any high frequency noise on the inputs, also improving performance. Values around 20pF are sufficient and can be used on AC coupled inputs as well. Note, however, that the value of capacitor C chosen must take into account the highest frequency component of the analog input signal.

A single ended source will give better overall system performance if it is first converted to differential before driving the HI5808.

**Digital I/O and Clock Requirements**

The HI5808 provides a standard high-speed interface to external TTL/CMOS logic families. The digital CMOS clock input has TTL level thresholds. The low input bias current allows the HI5808 to be driven by CMOS logic.

The digital CMOS outputs have a separate digital supply. This allows the digital outputs to operate from a 3.0V to 5.0V supply. When driving CMOS logic, the digital outputs will swing to the rails. When driving standard TTL loads, the digital outputs will meet standard TTL level requirements even with a 3.0V supply.

In order to ensure rated performance of the HI5808, the duty cycle of the clock should be held at 50% ±5%. It must also have low jitter and operate at standard TTL levels.

Performance of the HI5808 will only be guaranteed at conversion rates above 0.5 MSPS. This ensures proper performance of the internal dynamic circuits.

**Supply and Ground Considerations**

The HI5808 has separate analog and digital supply and ground pins to keep digital noise out of the analog signal path. The part should be mounted on a board that provides separate low impedance connections for the analog and digital supplies and grounds. For best performance, the supplies to the HI5808 should be driven by clean, linear regulated supplies. The board should also have good high frequency decoupling capacitors mounted as close as possible to the converter. If the part is powered off a single supply then the analog supply and ground pins should be isolated by ferrite beads from the digital supply and ground pins.

Refer to the Application Note AN9214, "Using Intersil High Speed A/D Converters" for additional considerations when using high speed converters.

**Static Performance Definitions**

**Offset Error (V<sub>OS</sub>)**

The midscale code transition should occur at a level 1/4 LSB above half-scale. Offset is defined as the deviation of the actual code transition from this point.

**Full-Scale Error (FSE)**

The last code transition should occur for an analog input that is 3/4 LSB below positive full scale with the offset error removed. Full-scale error is defined as the deviation of the actual code transition from this point.

**Differential Linearity Error (DNL)**

DNL is the worst case deviation of a code width from the ideal value of 1 LSB.

**Integral Linearity Error (INL)**

INL is the worst case deviation of a code center from a best fit straight line calculated from the measured data.

**Power Supply Rejection Ratio (PSRR)**

Each of the power supplies are moved plus and minus 5% and the shift in the offset and gain error (in LSBs) is noted.

## Dynamic Performance Definitions

Fast Fourier Transform (FFT) techniques are used to evaluate the dynamic performance of the HI5808. A low distortion sine wave is applied to the input, it is coherently sampled, and the output is stored in RAM. The data is then transformed into the frequency domain with an FFT and analyzed to evaluate the dynamic performance of the A/D. The sine wave input to the part is -0.5dB down from full scale for all these tests. SNR and SINAD are quoted in dB. The distortion numbers are quoted in dBc (decibels with respect to carrier) and **DO NOT** include any correction factors for normalizing to full scale.

### Signal-to-Noise Ratio (SNR)

SNR is the measured RMS signal to RMS noise at a specified input and sampling frequency. The noise is the RMS sum of all of the spectral components except the fundamental and the first five harmonics.

### Signal-to-Noise + Distortion Ratio (SINAD)

SINAD is the measured RMS signal to RMS sum of all other spectral components below the Nyquist frequency,  $f_S/2$ , excluding DC.

### Effective Number Of Bits (ENOB)

The effective number of bits (ENOB) is calculated from the SINAD data by:

$$\text{ENOB} = (\text{SINAD} + V_{\text{CORR}}^{-1.76})/6.02,$$

where:  $V_{\text{CORR}} = 0.5\text{dB}$ .

$V_{\text{CORR}}$  adjusts the ENOB for the amount the input is below full scale.

### Total Harmonic Distortion (THD)

THD is the ratio of the RMS sum of the first 5 harmonic components to the RMS value of the fundamental input signal.

### 2nd and 3rd Harmonic Distortion

This is the ratio of the RMS value of the applicable harmonic component to the RMS value of the fundamental input signal.

### Spurious Free Dynamic Range (SFDR)

SFDR is the ratio of the fundamental RMS amplitude to the RMS amplitude of the next largest spur or spectral component in the spectrum below  $f_S/2$ .

### Intermodulation Distortion (IMD)

Nonlinearities in the signal path will tend to generate intermodulation products when two tones,  $f_1$  and  $f_2$ , are present at the inputs. The ratio of the measured signal to the distortion terms is calculated. The terms included in the calculation are  $(f_1 + f_2)$ ,  $(f_1 - f_2)$ ,  $(2f_1)$ ,  $(2f_2)$ ,  $(2f_1 + f_2)$ ,  $(2f_1 - f_2)$ ,  $(f_1 + 2f_2)$ ,  $(f_1 - 2f_2)$ . The ADC is tested with each tone 6dB below full scale.

### Transient Response

Transient response is measured by providing a full-scale transition to the analog input of the ADC and measuring the number of cycles it takes for the output code to settle within 12-bit accuracy.

### Over-Voltage Recovery

Over-voltage Recovery is measured by providing a full-scale transition to the analog input of the ADC which overdrives the input by 200mV, and measuring the number of cycles it takes for the output code to settle within 12-bit accuracy.

### Full Power Input Bandwidth (FPBW)

Full power input bandwidth is the analog input frequency at which the amplitude of the digitally reconstructed output has decreased 3dB below the amplitude of the input sinewave. The input sinewave has an amplitude which swings from  $-f_S$  to  $+f_S$ . The bandwidth given is measured at the specified sampling frequency.

## Timing Definitions

Refer to Figure 1, Internal Circuit Timing, and Figure 2, Input-To-Output Timing, for these definitions.

### Aperture Delay ( $t_{AP}$ )

Aperture delay is the time delay between the external sample command (the falling edge of the clock) and the time at which the signal is actually sampled. This delay is due to internal clock path propagation delays.

### Aperture Jitter ( $t_{AJ}$ )

Aperture Jitter is the RMS variation in the aperture delay due to variation of internal clock path delays.

### Data Hold Time ( $t_H$ )

Data hold time is the time to where the previous data (N - 1) is no longer valid.

### Data Output Delay Time ( $t_{OD}$ )

Data output delay time is the time to where the new data (N) is valid.

### Data Latency ( $t_{LAT}$ )

After the analog sample is taken, the digital data is output on the bus at the third cycle of the clock. This is due to the pipeline nature of the converter where the data has to ripple through the stages. This delay is specified as the data latency. After the data latency time, the data representing each succeeding sample is output at the following clock pulse. The digital data lags the analog input sample by 3 clock cycles.

All Intersil semiconductor products are manufactured, assembled and tested under **ISO9000** quality systems certification.

*Intersil semiconductor products are sold by description only. Intersil Corporation reserves the right to make changes in circuit design and/or specifications at any time without notice. Accordingly, the reader is cautioned to verify that data sheets are current before placing orders. Information furnished by Intersil is believed to be accurate and reliable. However, no responsibility is assumed by Intersil or its subsidiaries for its use; nor for any infringements of patents or other rights of third parties which may result from its use. No license is granted by implication or otherwise under any patent or patent rights of Intersil or its subsidiaries.*

For information regarding Intersil Corporation and its products, see web site <http://www.intersil.com>

### **Sales Office Headquarters**

#### **NORTH AMERICA**

Intersil Corporation  
P. O. Box 883, Mail Stop 53-204  
Melbourne, FL 32902  
TEL: (321) 724-7000  
FAX: (321) 724-7240

#### **EUROPE**

Intersil SA  
Mercure Center  
100, Rue de la Fusee  
1130 Brussels, Belgium  
TEL: (32) 2.724.2111  
FAX: (32) 2.724.22.05

#### **ASIA**

Intersil (Taiwan) Ltd.  
7F-6, No. 101 Fu Hsing North Road  
Taipei, Taiwan  
Republic of China  
TEL: (886) 2 2716 9310  
FAX: (886) 2 2715 3029