

# SPECIFICATION

Customer: \_\_\_\_\_

Model Name: HJ080IA-01E

Date: 2012/06/15

Version: 03

Preliminary Specification

Final Specification

For Customer's Acceptance

Approved by	Comment

Approved by	Reviewed by	Prepared by
<b>Stanley CW Leung</b>  2012/06/27	<b>WenYi Wang</b>  2012/06/25	<b>Laurels Yang</b>  2012/06/15

### Record of Revision

Version	Revise Date	Page	Content
Pre-Spec.01	2012/01/09		Initial Release.
Pre-Spec.02	2012/04/03	7	Update current for LED backlight
		11	Update timing table
Pre-Spec.03	2012/6/15	23	Update Mechanical Drawing

# Contents

1. General Specifications .....	1
2. Pin Assignment .....	2
3. Operation Specifications .....	5
3.1. Absolute Maximum Ratings .....	5
3.2. Typical Operation Conditions .....	6
3.3. Current Consumption .....	7
3.4. Backlight Driving Conditions .....	7
3.5. Power Sequence .....	8
3.6. LVDS Signal Timing Characteristics .....	9
3.6.1. AC Electrical Characteristics .....	9
3.6.2. DC Electrical Characteristics .....	11
3.6.3. Timing Table .....	12
3.6.4. Data Input Format .....	13
4. Optical Specifications .....	14
5. Reliability Test Items .....	18
6. General Precautions .....	19
6.1. Safety .....	19
6.2. Handling .....	19
6.3. Static Electricity .....	19
6.4. Storage .....	19
6.5. Cleaning .....	19
7. Mechanical Drawing .....	20
8. Package Drawing .....	21
8.1. Package Material Table .....	21
8.2. Package Quantity .....	21
8.3. Package Drawing .....	21

# 1. General Specifications

No.	Item	Specification	Remark
1	LCD size	7.97 inch diagonal	
2	Driver element	a-Si TFT active matrix	
3	Resolution	1024 × 3(RGB) × 768	
4	Display mode	Normally Black, Transmissive	
5	Dot pitch	0.05275(W) × 0.15825(H) mm	
6	Active area	162.05(W) × 121.54(H) mm	
7	Module size	174.00 (W) × 136.00(H) × 2.60(D) mm	Note 1
8	Surface treatment	Hard Coating	
9	Color arrangement	RGB-stripe	
10	Interface	LVDS	
11	Backlight power consumption	2.046W	
12	Panel power consumption	0.383W	
13	Weight	(120G)	

Note 1: Refer to Mechanical Drawing.

## 2. Pin Assignment

Pin No.	Symbol	I/O	Function	Remark
1	VCOM	P	Common Voltage	
2	VDD	P	Power Voltage for digital circuit	
3	VDD	P	Power Voltage for digital circuit	
4	NC	---	No connection	
5	Reset	I	Global reset pin	
6	STBYB	I	Standby mode, Normally pulled high STBYB = "1", normal operation STBYB = "0", timing controller, source driver will turn off, all output are High-Z	
7	GND	P	Ground	
8	RXIN0-	I	- LVDS differential data input	
9	RXIN0+	I	+ LVDS differential data input	
10	GND	P	Ground	
11	RXIN1-	I	- LVDS differential data input	
12	RXIN1+	I	+ LVDS differential data input	
13	GND	P	Ground	
14	RXIN2-	I	- LVDS differential data input	
15	RXIN2+	I	+ LVDS differential data input	
16	GND	P	Ground	
17	RXCLKIN-	I	- LVDS differential clock input	
18	RXCLKIN+	I	+ LVDS differential clock input	
19	GND	P	Ground	
20	RXIN3-	I	- LVDS differential data input	
21	RXIN3+	I	+ LVDS differential data input	
22	GND	P	Ground	
23	NC	---	No connection	
24	NC	---	No connection	
25	GND	P	Ground	
26	NC	---	No connection	

27	DIMO	O	Backlight CABC controller signal output	
28	SELB	I	6bit/8bit mode select	Note1
29	AVDD	P	Power for Analog Circuit	
30	GND	P	Ground	
31	LED-	P	LED Cathode	
32	LED-	P	LED Cathode	
33	L/R	I	Horizontal inversion	Note3
34	U/D	I	Vertical inversion	Note3
35	VGL	P	Gate OFF Voltage	
36	CABCEN1	I	CABC H/W enable	Note2
37	CABCEN0	I	CABC H/W enable	Note2
38	VGH	P	Gate ON Voltage	
39	LED+	P	LED Anode	
40	LED+	P	LED Anode	

I: input, O: output, P: Power

Note1: If LVDS input data is 6 bits ,SELB must be set to High;

If LVDS input data is 8 bits ,SELB must be set to Low.

Note2: When CABC\_EN="00", CABC OFF.

When CABC\_EN="01", user interface image.

When CABC\_EN="10", still picture.

When CABC\_EN="11", moving image.

When CABC off, don't connect DIMO, else connect it to backlight.

Note3: When L/R="0", set right to left scan direction.

When L/R="1", set left to right scan direction.

When U/D="0", set top to bottom scan direction.

When U/D="1", set bottom to top scan direction.

Note: Definition of scanning direction.  
Refer to the figure as below:

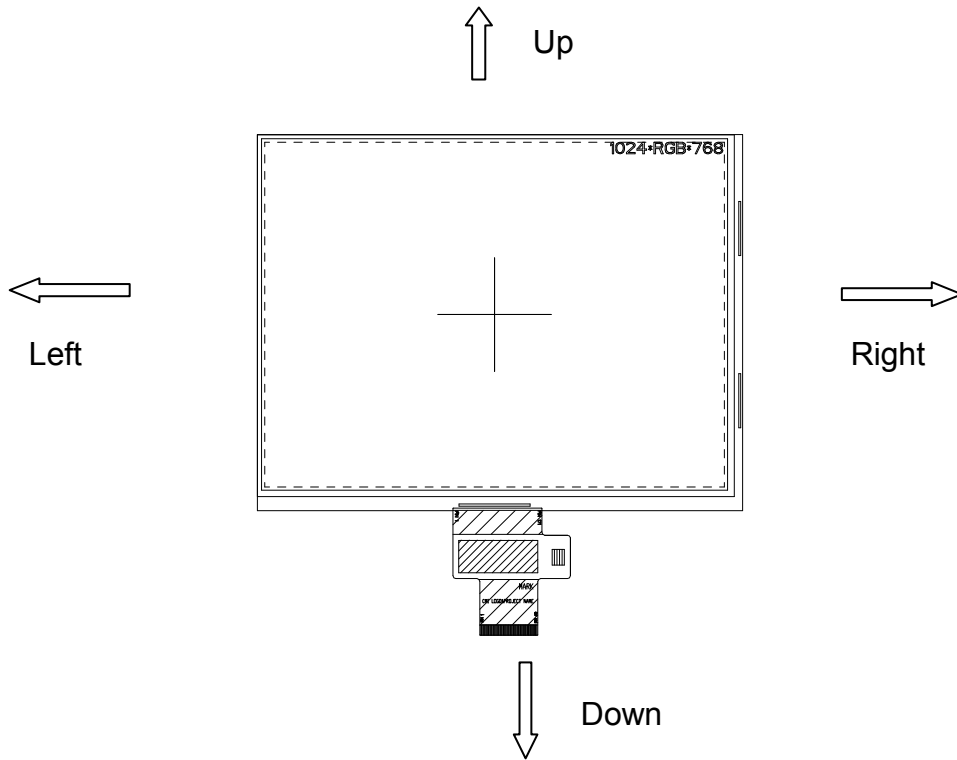

## 3. Operation Specifications

### 3.1. Absolute Maximum Ratings

(GND=AV<sub>SS</sub>=0V,Note 1)

Item	Symbol	Values		Unit	Remark
		Min.	Max.		
Power voltage	VCC	-0.3	5.0	V	GND=0V, TA=25°C
	AVDD	6.5	13.5	V	
	V <sub>GH</sub>	-0.3	40.0	V	
	V <sub>GL</sub>	-20.0	0.3	V	
	V <sub>GH</sub> -V <sub>GL</sub>	-	40.0	V	
Operation Temperature	T <sub>OP</sub>	-10	60	°C	
Storage Temperature	T <sub>ST</sub>	-20	70	°C	
LED Reverse Voltage	V <sub>R</sub>	-	5	V	Each LED
LED Forward Current	I <sub>F</sub>	-	35	mA	Each LED

Note 1: The absolute maximum rating values of this product are not allowed to be exceeded at any times. Should a module be used with any of the absolute maximum ratings exceeded, the characteristics of the module may not be recovered, or in an extreme case, the module may be permanently destroyed.



## 3.2. Typical Operation Conditions

(GND=AV<sub>SS</sub>=0V, Note 1)

Item	Symbol	Values			Unit	Remark
		Min.	Typ.	Max.		
Power voltage	V <sub>CC</sub>	3.0	3.3	3.6	V	Note 2
	AV <sub>DD</sub>	9.8	10	10.2	V	
	V <sub>GH</sub>	18.6	18.9	19.2	V	
	V <sub>GL</sub>	-8.1	-7.8	-7.5	V	
Input signal voltage	V <sub>COM</sub>	2.6	3.6	4.6	V	Note 3
Input logic high voltage	V <sub>IH</sub>	0.7V <sub>CC</sub>	-	V <sub>CC</sub>	V	Note 4
Input logic low voltage	V <sub>IL</sub>	0	-	0.3V <sub>CC</sub>	V	

Note 1: Be sure to apply V<sub>DD</sub> and V<sub>GL</sub> to the LCD first, and then apply V<sub>GH</sub>.

Note 2: V<sub>DD</sub> setting should match the signals output voltage (refer to Note 3) of customer's system board.

Note 3: Typical V<sub>com</sub> is only a reference value, it must be optimized according to each LCM, please use VR and base on below application circuit..

Note 4: RESET, STBYB, SELB, L/R, U/D, CAB CEN0, CAB CEN1.

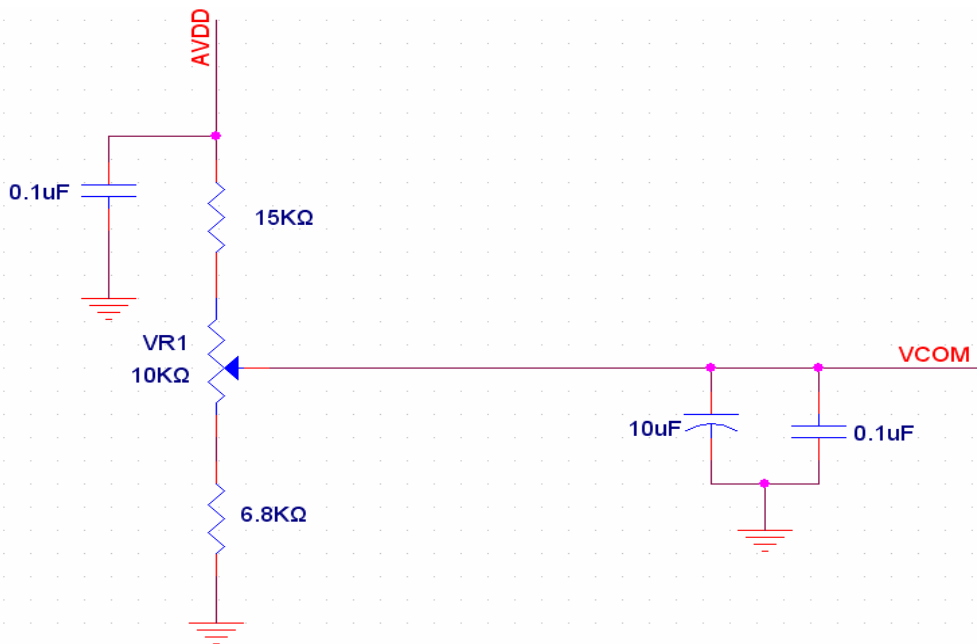

### 3.3. Current Consumption

(GND=AVSS=0V)

Item	Symbol	Values			Unit	Remark
		Min.	Typ.	Max.		
Current for Driver	$I_{GH}$	-	0.65	1.0	mA	VGH=18.9V
	$I_{GL}$	-	0.65	1.0	mA	VGL=-7.8V
	$I_{CC}$	-	35	60	mA	Vcc=3.3V
	$I_{AVDD}$	-	25	40	mA	AVDD=10.0V

### 3.4. Backlight Driving Conditions

Item	Symbol	Values			Unit	Remark
		Min.	Typ.	Max.		
Voltage for LED backlight	$V_L$	8.4	9.3	10.2	V	Note 1
Current for LED backlight	$I_L$	198	220	242	mA	
LED life time	-	-	20,000	-	Hr	Note 2

Note 1: The LED Supply Voltage is defined by the number of LED at Ta=25°C and  $I_L=220\text{mA}$ .

Note 2: The “LED life time” is defined as the module brightness decrease to 50% original brightness at Ta=25°C and  $I_L=220\text{mA}$ . The LED lifetime could be decreased if operating  $I_L$  is larger than 220mA.

### 3.5. Power Sequence

#### a. Power on:

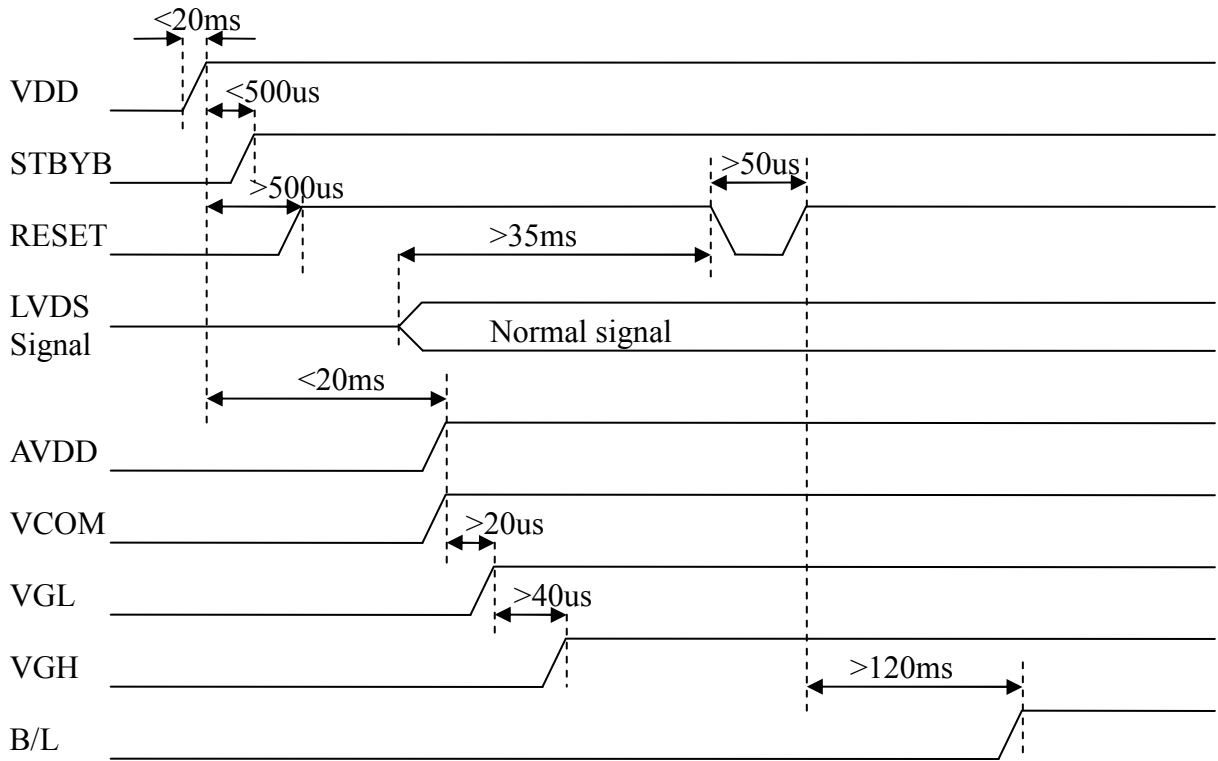

#### b. Power off:

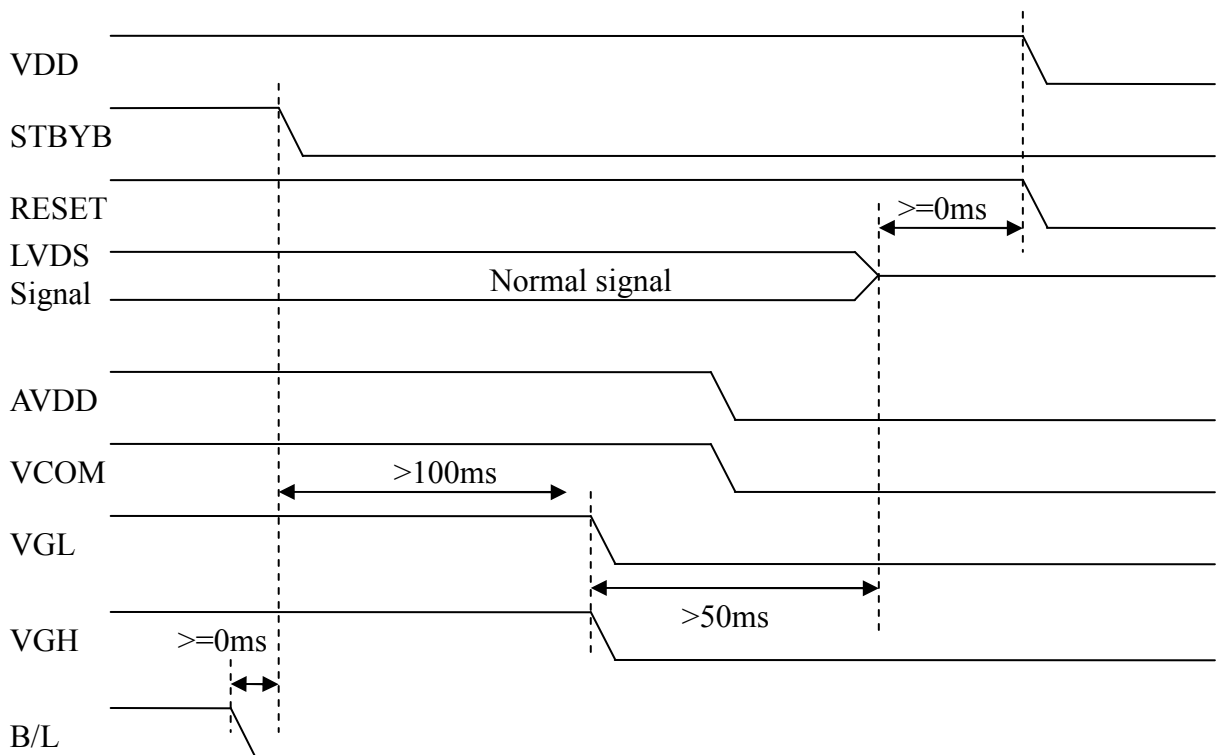

### 3.6. LVDS Signal Timing Characteristics

#### 3.6.1. AC Electrical Characteristics

Parameter	Symbol	Values			Unit	Remark
		Min.	Typ.	Max.		
Clock frequency	$R_{xFCLK}$	20	-	71	MHz	
Input data skew margin	$T_{RSKM}$	500	-	-	ps	
Clock high time	$T_{LVCH}$	-	$4/(7 * R_{xFCLK})$	-	ns	
Clock low time	$T_{LVCL}$	-	$3/(7 * R_{xFCLK})$	-	ns	

### 3.6.2. Input Clock and Data Timing Diagram

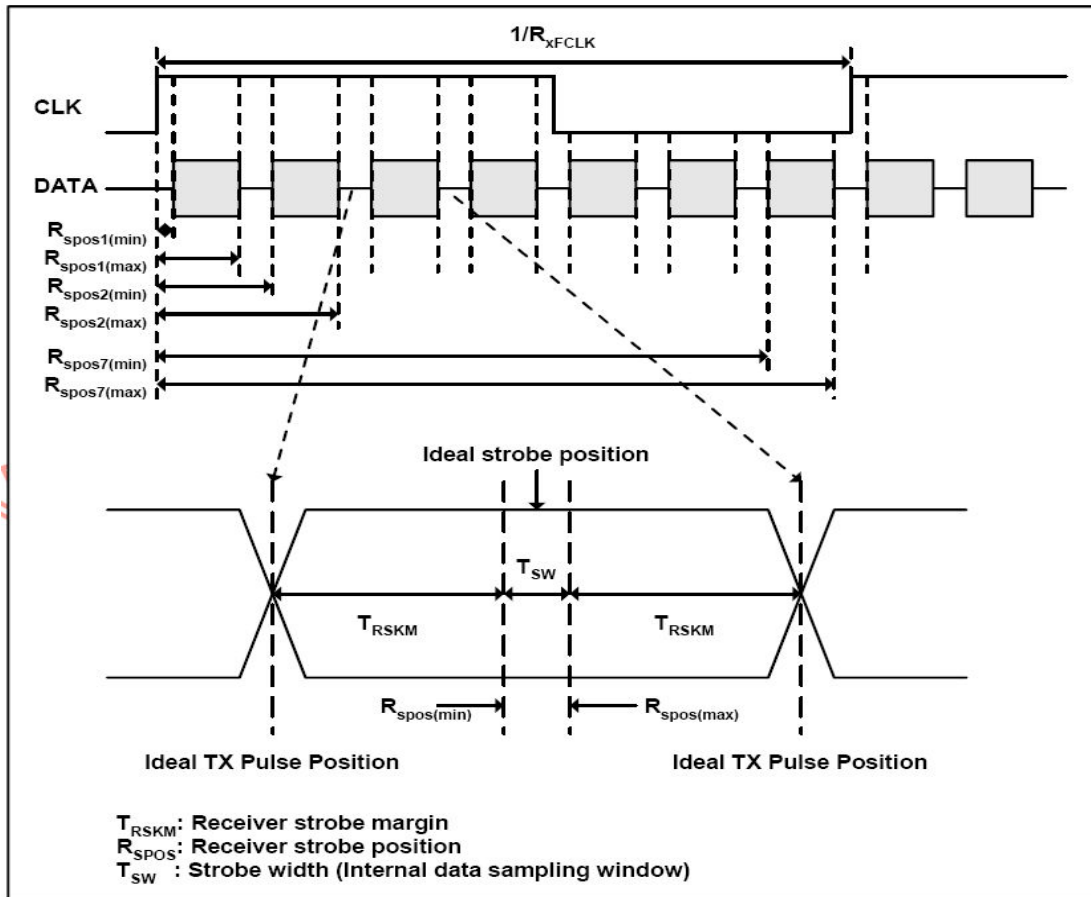

### 3.6.3. DC Electrical Characteristics

Parameter	Symbol	Values			Unit	Remark
		Min.	Typ.	Max.		
Differential input high Threshold voltage	$R_{xVTH}$	-	-	+0.1	V	$R_{xVCM}=1.2V$
Differential input low Threshold voltage	$R_{xVTL}$	-0.1	-	-	V	
Input voltage range (singled-end)	$R_{xVIN}$	0	-	2.4	V	
Differential input common mode voltage	$R_{xVCM}$	$ V_{ID} /2$	-	$2.4- V_{ID} /2$	V	
Differential voltage	$ V_{ID} $	0.2	-	0.6	V	
Differential input leakage current	$R_{V_{xliz}}$	-10	-	+10	$\mu A$	

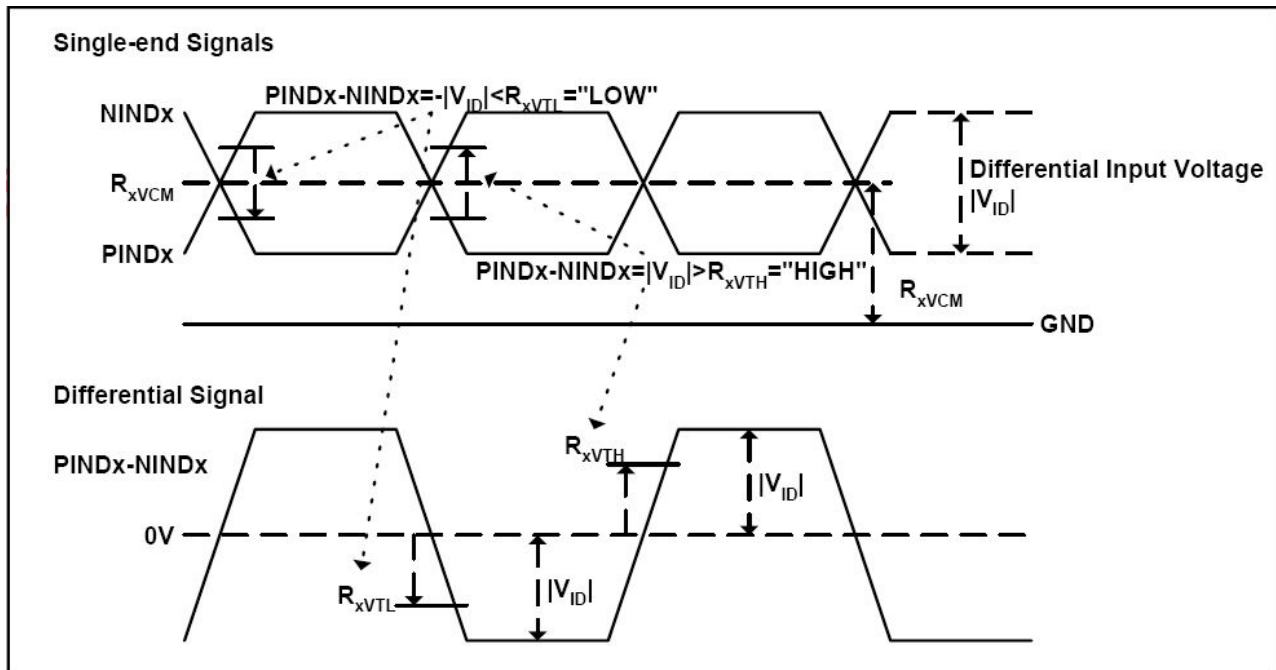

### 3.6.4. Timing Table

Item	Symbol	Values			Unit	Remark
		Min.	Typ.	Max.		
Clock Frequency	fclk	52	65	71	MHz	Frame rate =TBD
Horizontal display area	thd	1024				
HS period time	th	1114	1344	1400	DCLK	
HS Blanking	thb+thfp	90	320	376	DCLK	
Vertical display area	tvd	768				
VS period time	tv	778	806	845	H	
VS Blanking	tvb+tvfp	10	38	77	H	

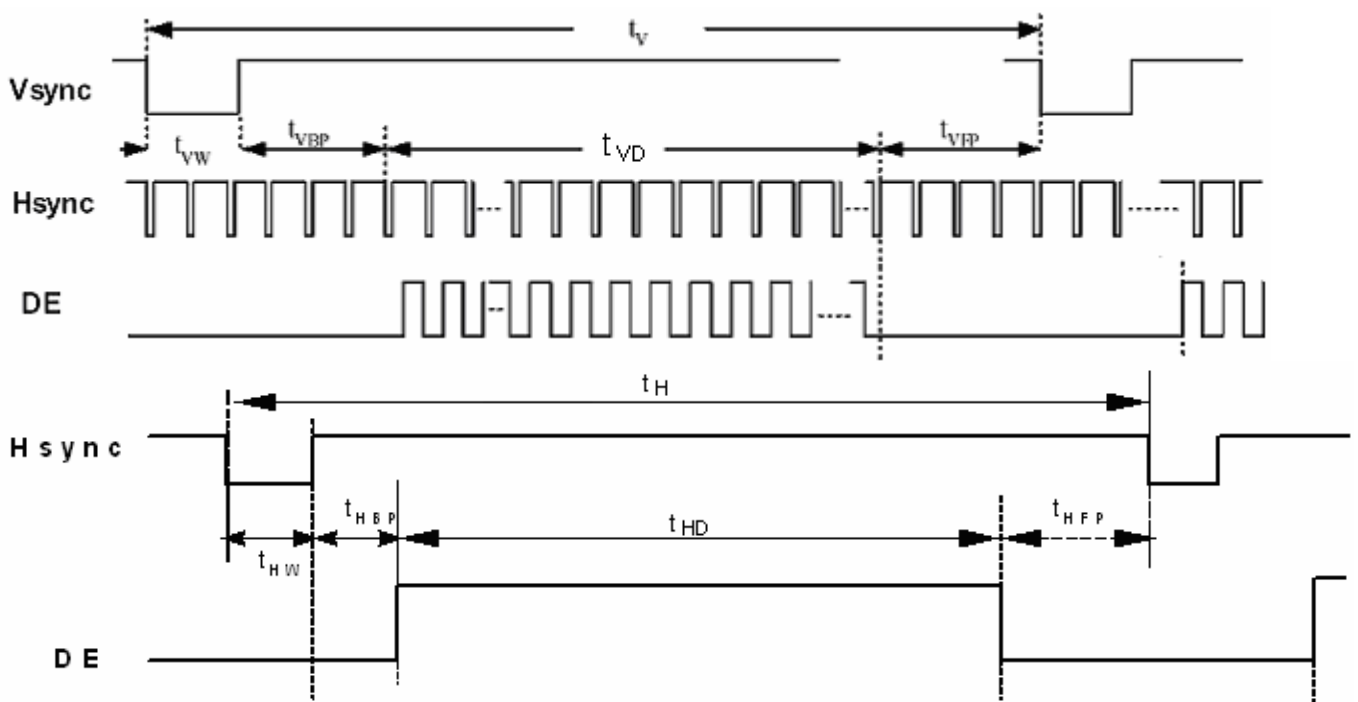

### 3.6.5. Data Input Format

#### 6bit LVDS input

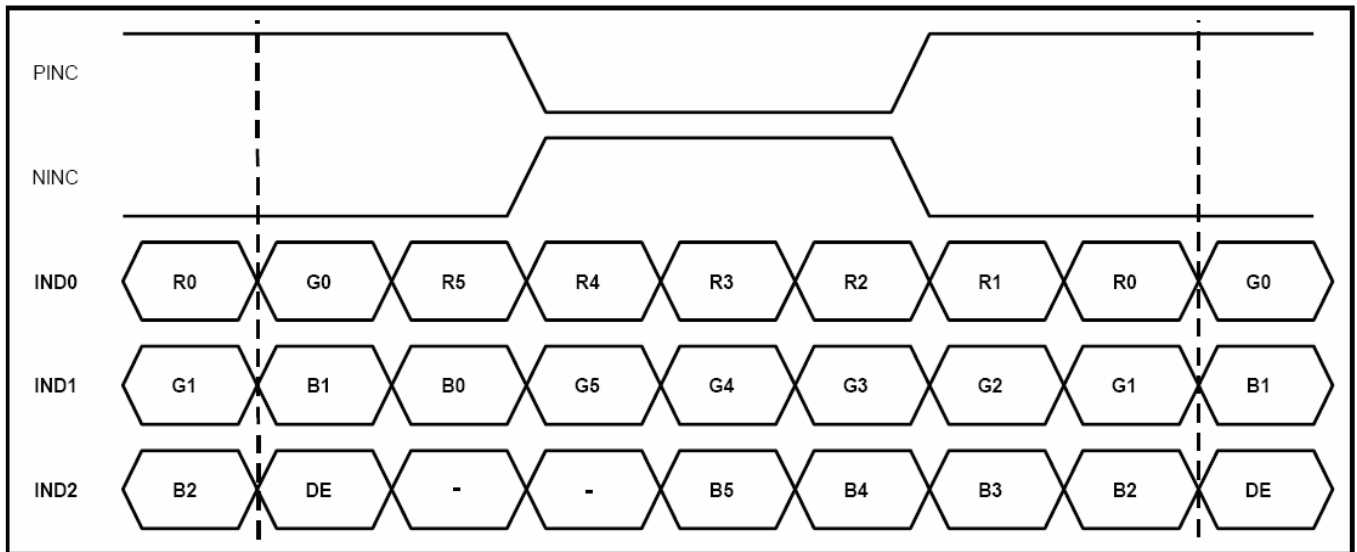

#### 8bit LVDS input

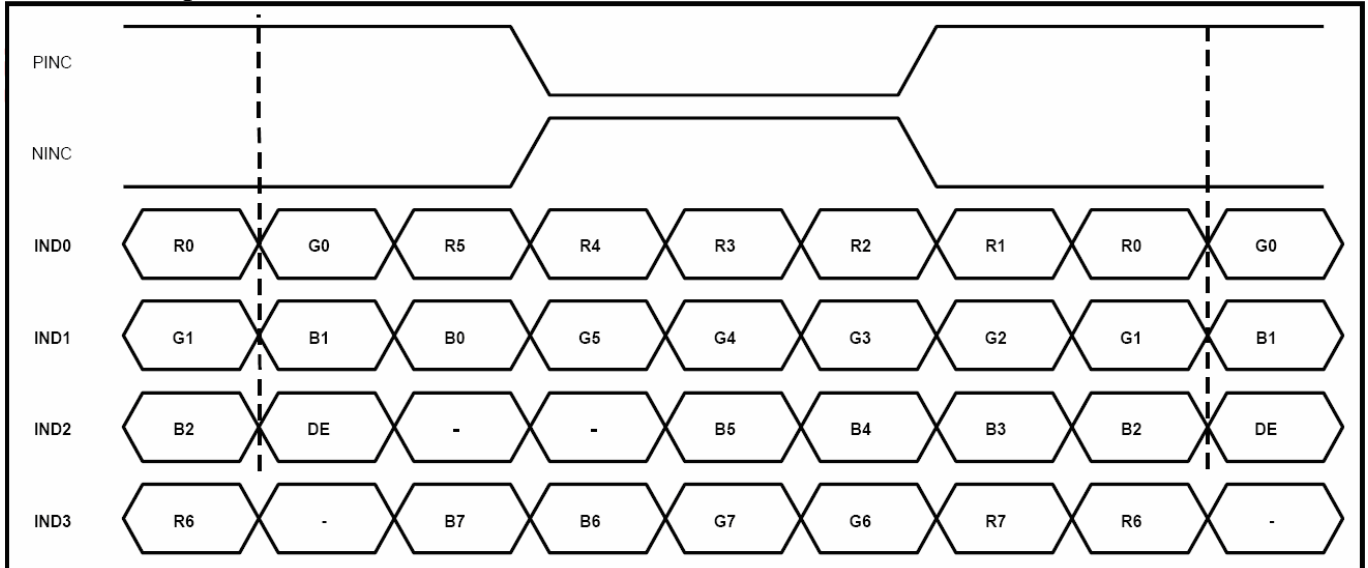

Note: Support DE timing mode only, SYNC mode not supported



## 4. Optical Specifications

Item	Symbol	Condition	Values			Unit	Remark
			Min.	Typ.	Max.		
Viewing angle (CR≥ 10)	$\theta_L$	$\Phi=180^\circ$ (9 o'clock)	75	85	-	degree	Note 1
	$\theta_R$	$\Phi=0^\circ$ (3 o'clock)	75	85	-		
	$\theta_T$	$\Phi=90^\circ$ (12 o'clock)	75	85	-		
	$\theta_B$	$\Phi=270^\circ$ (6 o'clock)	75	85	-		
Response time	$T_{ON}$	Normal $\theta=\Phi=0^\circ$	-	25	50	msec	Note 2 Note 3
	$T_{OFF}$						
Contrast ratio	CR		600	800	-	-	Note 4
Color chromaticity	$W_X$		0.238	0.288	0.338	-	Note 2 Note 5 Note 6
	$W_Y$		0.276	0.326	0.376	-	
Luminance	L		300	350	-	cd/m <sup>2</sup>	Note 6
Luminance uniformity	$Y_U$		70	80	-	%	Note 7
NTSC				50		%	

### Test Conditions:

1.  $DV_{DD}=3.1V$ ,  $I_L=220mA$  (Backlight current), the ambient temperature is  $25^\circ C$ .
2. The test systems refer to Note 2.

Note 1: Definition of viewing angle range

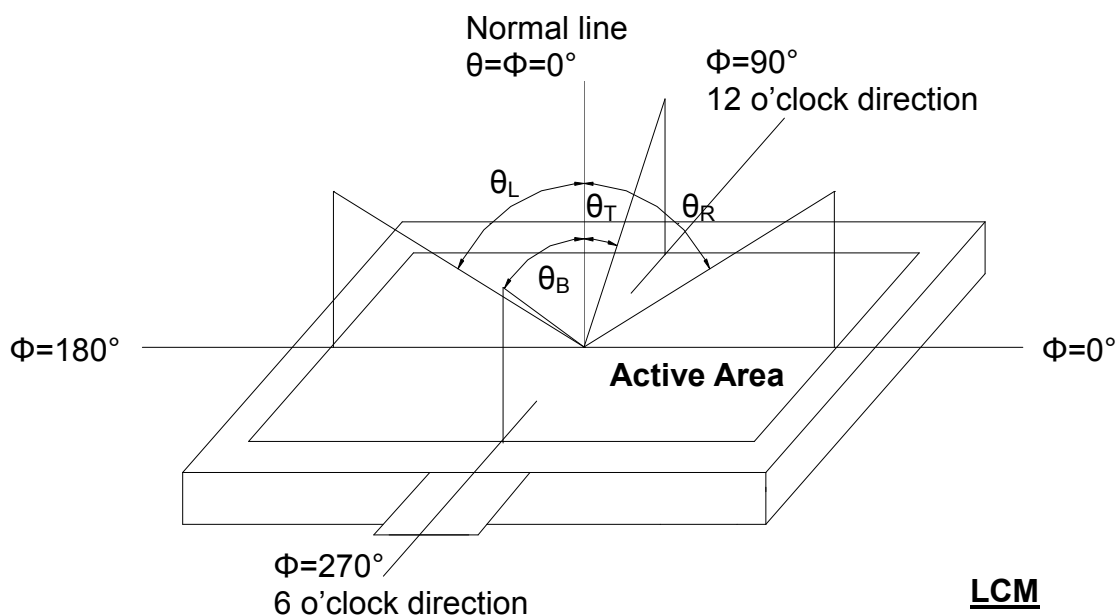

Fig. 4-1 Definition of viewing angle

Note 2: Definition of optical measurement system.

The optical characteristics should be measured in dark room. After 30 minutes operation, the optical properties are measured at the center point of the LCD screen. (Response time is measured by Photo detector TOPCON BM-7, other items are measured by BM-5A/Field of view: 1° /Height: 500mm.)

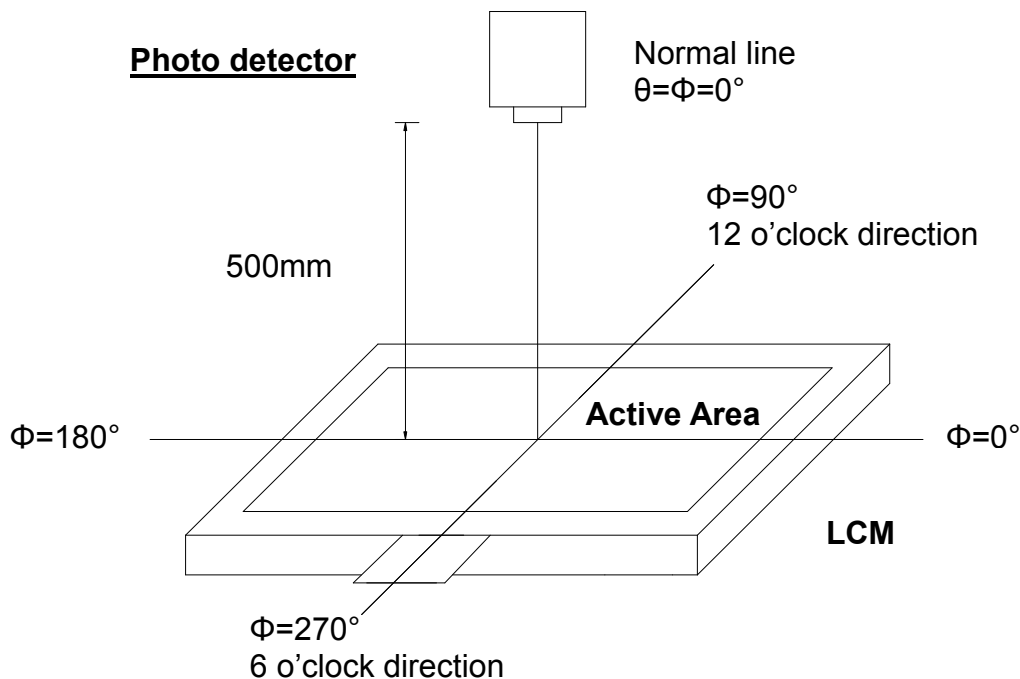

Fig. 4-2 Optical measurement system setup

Note 3: Definition of Response time

The response time is defined as the LCD optical switching time interval between “White” state and “Black” state. Rise time ( $T_{ON}$ ) is the time between photo detector output intensity changed from 90% to 10%. And fall time ( $T_{OFF}$ ) is the time between photo detector output intensity changed from 10% to 90%.

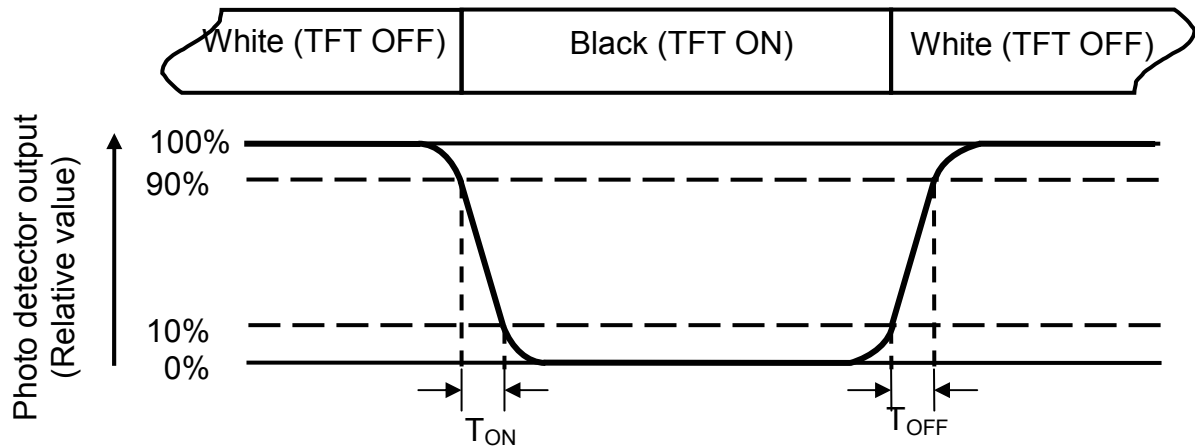

Fig. 4-3 Definition of response time

Note 4: Definition of contrast ratio

$$\text{Contrast ratio (CR)} = \frac{\text{Luminance measured when LCD on the "White" state}}{\text{Luminance measured when LCD on the "Black" state}}$$

Note 5: Definition of color chromaticity (CIE1931)

Color coordinates measured at center point of LCD.

Note 6: Definition of luminance:

Measured at the center area of the panel when LCD panel is driven at “white” state. The LED driving condition is  $I_L=220\text{mA}$ .

Note 7: Definition of Luminance Uniformity

Active area is divided into 9 measuring areas (Refer to Fig. 4-4 ).Every measuring point is placed at the center of each measuring area.

$$\text{Luminance Uniformity (Yu)} = \frac{B_{min}}{B_{max}}$$

L-----Active area length      W----- Active area width

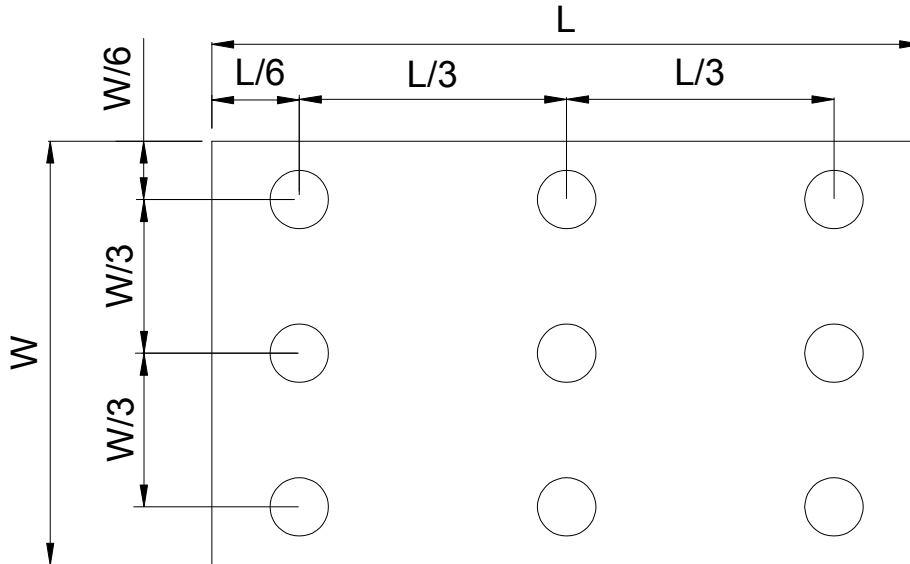

Fig. 4-4 Definition of measuring points

**B<sub>max</sub>**: The measured maximum luminance of all measurement position.

**B<sub>min</sub>**: The measured minimum luminance of all measurement position.

## 5. Reliability Test Items

(Note3)

Item	Test Conditions	Remark
High Temperature Storage	Ta = 70°C 240hrs	Note 1, Note 4
Low Temperature Storage	Ta = -20°C 240hrs	Note 1, Note 4
High Temperature Operation	Ts = 60°C 240hrs	Note 2, Note 4
Low Temperature Operation	Ta = -10°C 240hrs	Note 1, Note 4
Operate at High Temperature and Humidity	+40°C, 90%RH 240hrs	Note 4
Thermal Shock	-10°C/30 min ~ +60°C/30 min for a total 100 cycles, Start with cold temperature and end with high temperature.	Note 4
Vibration Test	Frequency range:10~55Hz Stroke:1.5mm Sweep:10Hz~55Hz~10Hz 2 hours for each direction of X. Y. Z. (6 hours for total)	
Mechanical Shock	100G 6ms,±X, ±Y, ±Z 3 times for each direction	
Package Vibration Test	Sine wave, 10~50~10Hz 1.5G, 0.37oct/min 3 axis, 1hour/axis	
Package Drop Test	Height:60 cm 1 corner, 3 edges, 6 surfaces	
Electro Static Discharge	± 2KV, Human Body Mode, 100pF/1500Ω	

Note 1: Ta is the ambient temperature of samples.

Note 2: Ts is the temperature of panel's surface.

Note 3: In the standard condition, there shall be no practical problem that may affect the display function. After the reliability test, the product only guarantees operation, but don't guarantee all of the cosmetic specification.

Note 4: Before cosmetic and function test, the product must have enough recovery time, at least 2 hours at room temperature.

## 6. General Precautions

### 6.1. Safety

Liquid crystal is poisonous. Do not put it in your mouth. If liquid crystal touches your skin or clothes, wash it off immediately by using soap and water.

### 6.2. Handling

1. The LCD panel is plate glass. Do not subject the panel to mechanical shock or to excessive force on its surface.
2. The polarizer attached to the display is easily damaged. Please handle it carefully to avoid scratch or other damages.
3. To avoid contamination on the display surface, do not touch the module surface with bare hands.
4. Keep a space so that the LCD panels do not touch other components.
5. Put cover board such as acrylic board on the surface of LCD panel to protect panel from damages.
6. Transparent electrodes may be disconnected if you use the LCD panel under environmental conditions where the condensation of dew occurs.
7. Do not leave module in direct sunlight to avoid malfunction of the ICs.

### 6.3. Static Electricity

1. Be sure to ground module before turning on power or operating module.
2. Do not apply voltage which exceeds the absolute maximum rating value.

### 6.4. Storage

1. Store the module in a dark room where must keep at  $25\pm 10^{\circ}\text{C}$  and 65%RH or less.
2. Do not store the module in surroundings containing organic solvent or corrosive gas.
3. Store the module in an anti-electrostatic container or bag.

### 6.5. Cleaning

1. Do not wipe the polarizer with dry cloth. It might cause scratch.
2. Only use a soft sloth with IPA to wipe the polarizer, other chemicals might permanent damage to the polarizer.

# 7. Mechanical Drawing

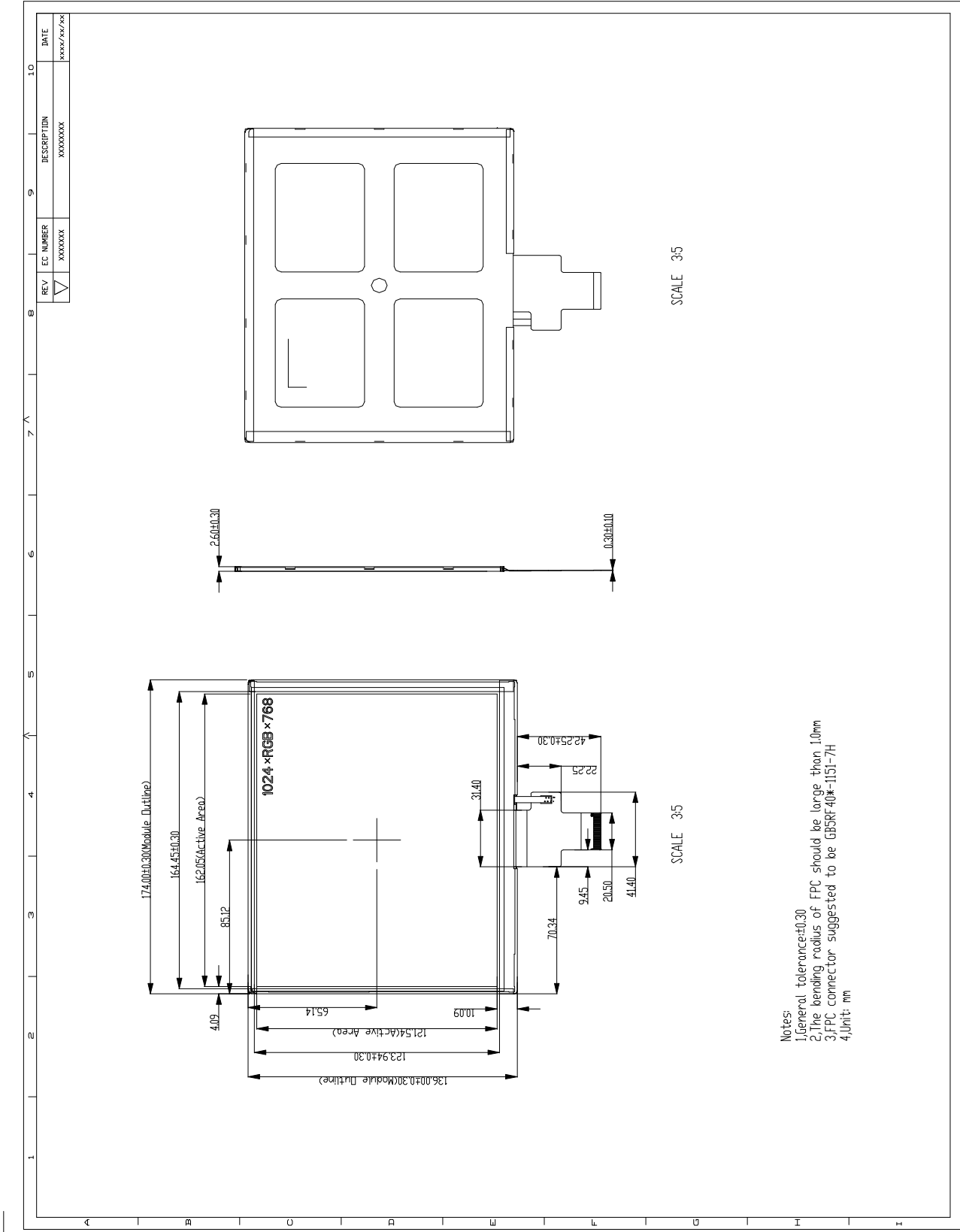

SCALE 3:5

SCALE 3:5

- Notes:
- 1.General tolerance:  $\pm 0.30$
  - 2.The bending radius of FPC should be large than 1.0mm
  - 3.FPC connector suggested to be GBSRF40X-1151-7H
  - 4.Unit: mm

## 8. Package Drawing

### 8.1. Package Material Table

No	Item	Model (Material)	Dimensions(mm)	Unit Weight (Kg)	Quantity (pcs)	Remark
1	LCM module	HJ0801A-01E	174.00×136.00×2.60	0.120	TBD	
2	Bubble Bag	PE	TBD	TBD	TBD	
3	Crepe Paper Tape	Tape	TBD	TBD	TBD	
4	Partition	CORRUGATED PAPER	TBD	TBD	TBD	set
5	Corrugated Bar	CORRUGATED PAPER	TBD	TBD	TBD	
6	Dust-Proof Bag	PE	TBD	TBD	TBD	
7	Carton	CORRUGATED PAPER	TBD	TBD	TBD	
8	Total weight	(TBD)± 5%KG				

### 8.2. Package Quantity

Total LCM quantity in Carton: no. of Partition	Rows x	quantity per Row	=
--	--------	------------------	---

TBD

### 8.3. Package Drawing

TBD