

Legacy Device: Harris JAN0512

Features

- FIELD PROGRAMMABLE
- 64 WORDS/8 BITS PER WORD
- FULLY DECODED
- DTL/TTL COMPATABLE
- 55ns ACCESS TIME (TYPICAL)
- OPERATING TEMPERATURE; $T_A = -55^{\circ}\text{C TO } +125^{\circ}\text{C}$

Description

The HL0512 is a field programmable 64 word by 8 bit PROM. In an unprogrammed memory, all "Memory Elements" are short circuits so that logical "zeros" appear at each output bit position for any address input. "Electronic Programming" involves the alteration of specific "Memory Elements" to create logical "ones" in selected bit positions. This alteration is irreversible and cannot be accomplished under normal operating conditions.

Pinout

TOP VIEW – D.I.P.

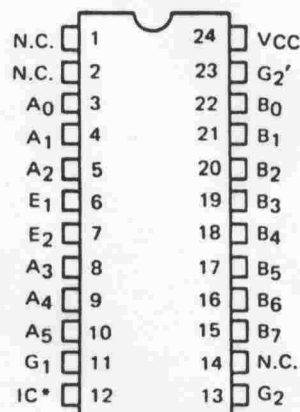

*Must be left open circuit

Block Diagram

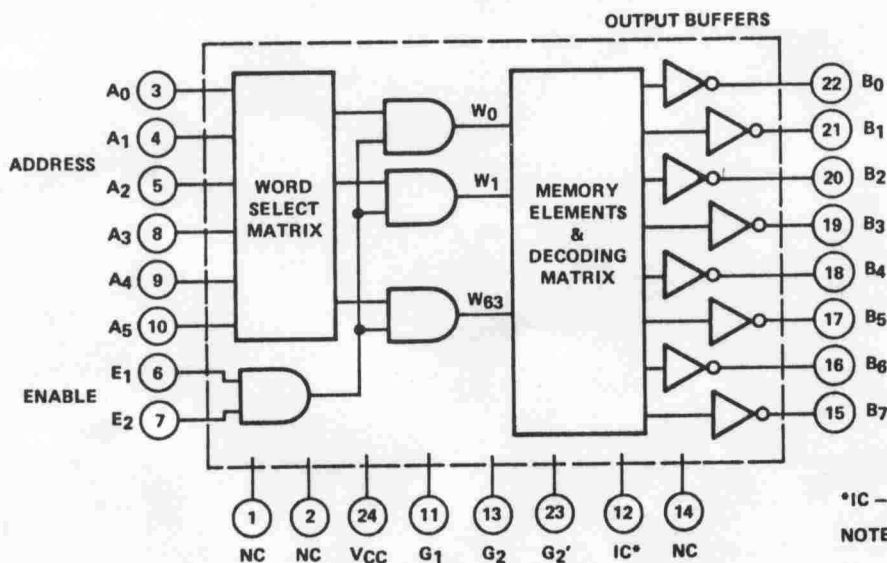

*IC – Internal Connection must be left open

NOTE: For operational condition, return pins 11, 13, and 23 to system ground.

www.DataSheet4U.com

Characteristic Curves

OUTPUT CHARACTERISTICS

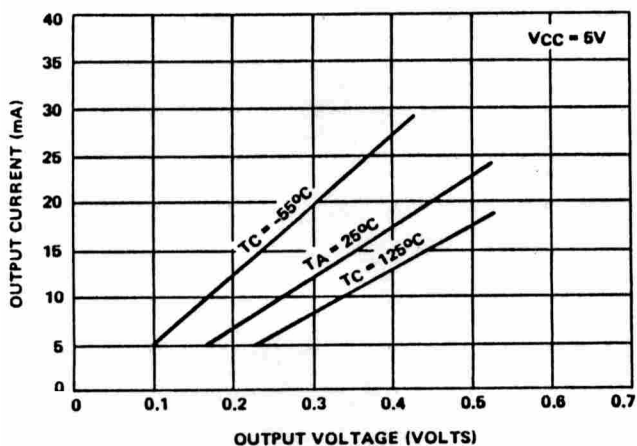

OUTPUT CURRENT vs. TEMPERATURE

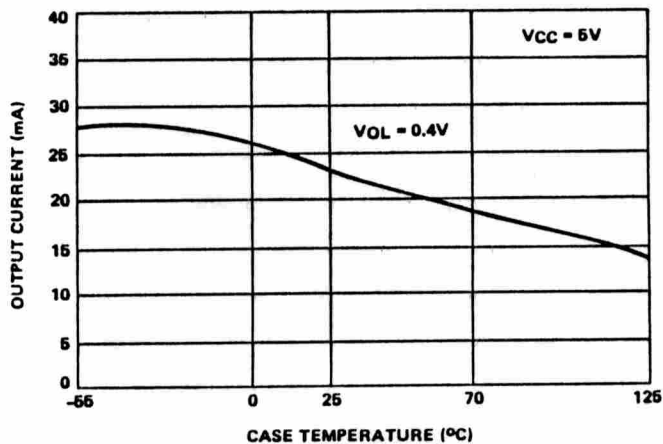

POWER SUPPLY CURRENT vs. TEMPERATURE

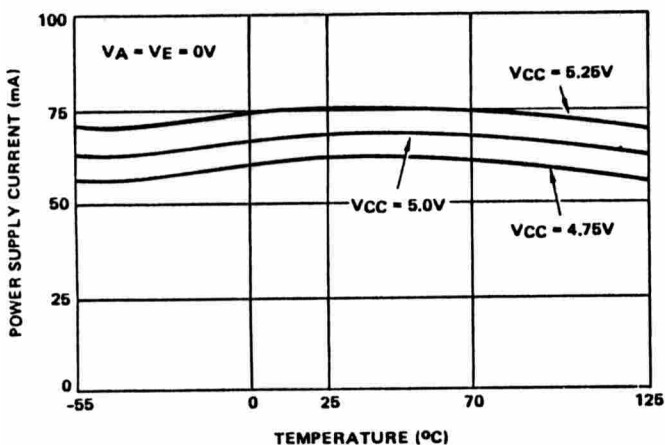

PROPAGATION DELAY vs. TEMPERATURE

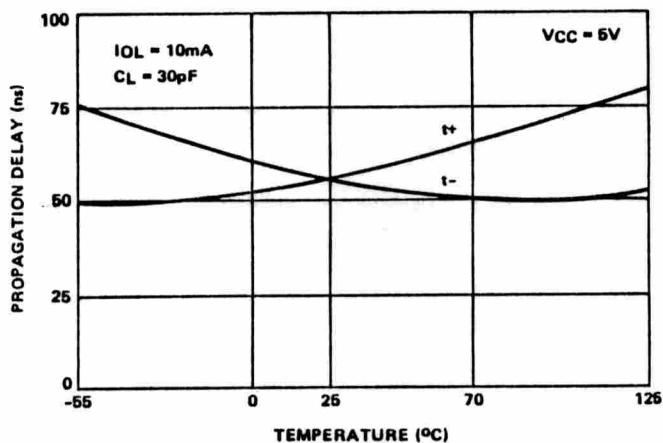

Switching Time Test Circuits

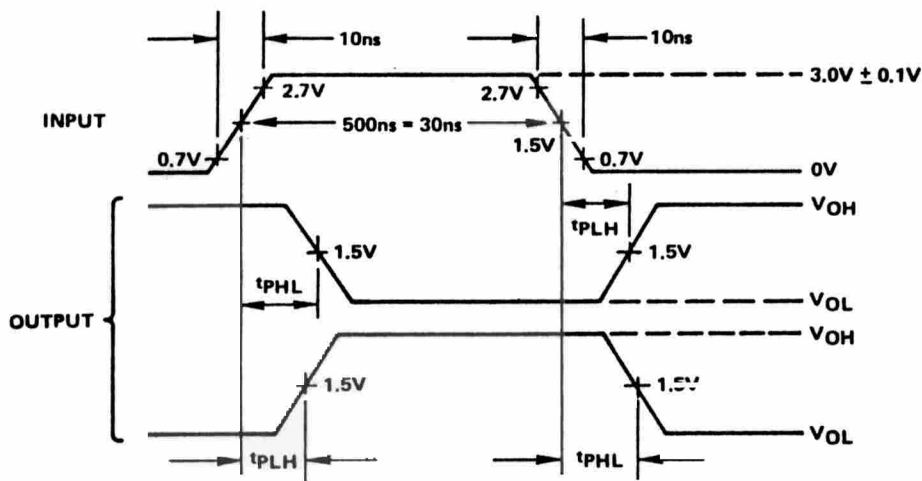
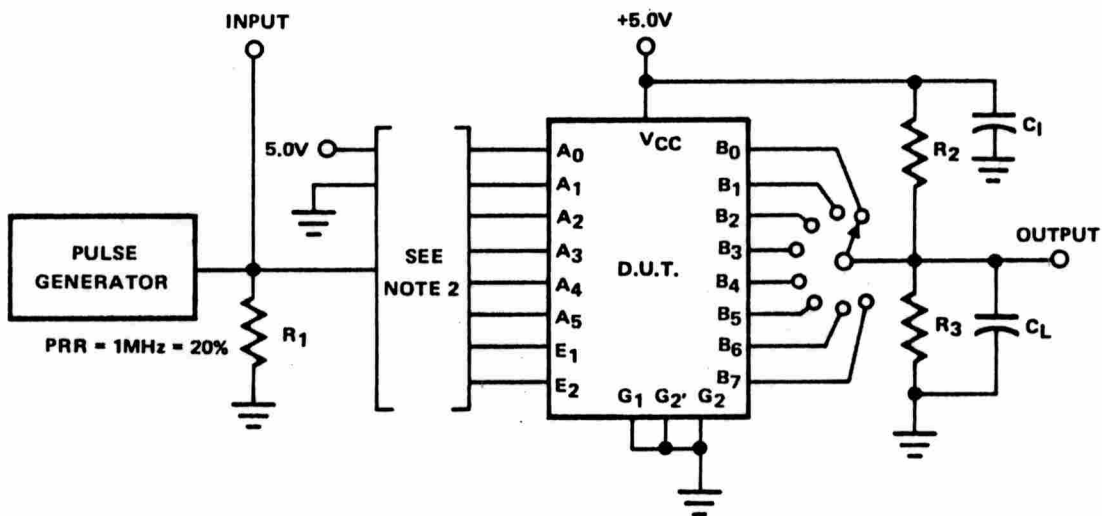

NOTES:

1. Pins 12 and 14 shall be left open.
2. The applicable test table should be selected from the altered item drawing.
3. $C_1 = 0.5\mu F \pm 10\%$; $R_1 = 50\Omega \pm 5\%$; $R_2 = 470\Omega \pm 5\%$; $R_3 = 1k\Omega \pm 5\%$; $C_L = 30pF$ including jig and probe capacitance.

ABSOLUTE MAXIMUM RATINGS

Supply Voltage Range	-0.5 V _{DC} to 7.0 V _{DC}
Input Voltage Range	-1.5 V _{DC} at -12mA to 5.5V _{DC}
Storage Temperature Range	-65°C to +150°C
Lead Temperature (Soldering 10 Seconds)	300°C
Thermal Resistance, Junction-to-Case	JC' Case J = 30°C/W
Output Supply Voltage	-0.5V _{DC} to 7.0V _{DC}
Output Sink Current	+30mA
Maximum Power Dissipation, P _D	575mWdc
Maximum Junction Temperature, T _J	175°C

RECOMMENDED OPERATING CONDITIONS

Supply Voltage	4.75 V _{DC} Min. to 5.25V _{DC} Maximum
Minimum High Level Input Voltage	2.0V _{DC}
Maximum Low Level Input Voltage	0.8V _{DC}
Normalized Fanout (Each Output)	6 Maximum (10mA)
Ambient Operating Temperature Range	-55°C to +125°C

ELECTRICAL CHARACTERISTICS

The electrical characteristics are as specified in the table and apply over the full recommended ambient operating temperature range, unless otherwise specified.

SYMBOL	TEST	LIMITS		UNITS	TEST CONDITIONS
		MIN	MAX		
VOL	Low Level Output Voltage		0.45	Volts	VCC = 4.75V VIN = 2.0V IOL = 10mA
VIC	Input Clamp Voltage		-1.5	Volts	VCC = 4.75V IIN = -12mA TA = 25°C
ICEX1	Maximum Collector Cut-Off Current		100	μA	VCC = 5.25V VOH = 2.8V VIN = 0.8V
ICEX2			200	μA	VCC = 5.25V VOH = 5.25V VIN = 0.8V
I _{IH1}	High Level Input Current		60	μA	VCC = 5.25V VIN = 2.4V;
I _{IH2}			100	μA	VCC = 5.25V VIN = 5.25; ①
I _{IL}	Low Level Input Current	-0.2	-1.6	mA	VCC = 5.25V VIN = 0.4V; ②
I _{CC}	Supply Current		100	mA	VCC = 5.25V VIN = 0
t _{PHL}	Propagation Delay Time High-to-Low Level Logic	25	140	ns	VCC = 5.0V CL = 30pF Min. R1 = 470 Ω ±5%
t _{PLH}	Propagation Delay Time Low-to-High Level Logic	25	140	ns	

NOTES: 1. When testing one E input, apply 5.25V to the other.
2. When testing one E input, apply GND to the other.

Lansdale Semiconductor reserves the right to make changes without further notice to any products herein to improve reliability, function or design. Lansdale does not assume any liability arising out of the application or use of any product or circuit described herein; neither does it convey any license under its patent rights nor the rights of others. "Typical" parameters which may be provided in Lansdale data sheets and/or specifications can vary in different applications, and actual performance may vary over time. All operating parameters, including "Typicals" must be validated for each customer application by the customer's technical experts. Lansdale Semiconductor is a registered trademark of Lansdale Semiconductor, Inc.